

(19) World Intellectual Property Organization
International Bureau



(43) International Publication Date
1 December 2005 (01.12.2005)

PCT

(10) International Publication Number
WO 2005/114118 A1

(51) International Patent Classification⁷: G01J 3/46

OH 45066 (US). **BODNAR, Gary** [US/US]; 2380 Pine Brook Lane, Springboro, OH 45066 (US). **SEIBERT, Karl, F.** [US/US]; 1725 Boesel Avenue, Kettering, OH 45429 (US). **DUKE, Ronald, J.** [US/US]; 1449 Ambridge Drive, Centerville, OH 45342 (US).

(21) International Application Number:
PCT/US2005/016722

(22) International Filing Date: 13 May 2005 (13.05.2005)

(25) Filing Language: English

(74) Agents: **LEVY, Mark, P.** et al.; Thompson Hine LLP, 2000 Courthouse Plaza Northeast, 10 West Second Street, Dayton, OH 45402-1758 (US).

(26) Publication Language: English

(30) Priority Data:
60/570,562 13 May 2004 (13.05.2004) US
60/570,563 13 May 2004 (13.05.2004) US

(81) Designated States (unless otherwise indicated, for every kind of national protection available): AE, AG, AL, AM, AT, AU, AZ, BA, BB, BG, BR, BW, BY, BZ, CA, CH, CN, CO, CR, CU, CZ, DE, DK, DM, DZ, EC, EE, EG, ES, FI, GB, GD, GE, GH, GM, HR, HU, ID, IL, IN, IS, JP, KE, KG, KM, KP, KR, KZ, LC, LK, LR, LS, LT, LU, LV, MA, MD, MG, MK, MN, MW, MX, MZ, NA, NG, NI, NO, NZ, OM, PG, PH, PL, PT, RO, RU, SC, SD, SE, SG, SK, SL, SM, SY, TJ, TM, TN, TR, TT, TZ, UA, UG, US, UZ, VC, VN, YU, ZA, ZM, ZW.

(71) Applicant (for all designated States except US): **COLOR SAVVY SYSTEMS LIMITED** [US/US]; 724 Pleasant Valley Drive, Springboro, OH 45066 (US).

(72) Inventors; and

(75) Inventors/Applicants (for US only): **PEARSON, Christopher, H.** [US/US]; 10 Belvoir Court, Springboro,

[Continued on next page]

(54) Title: METHOD FOR COLLECTING DATA FOR COLOR MEASUREMENTS FROM A DIGITAL ELECTRONIC IMAGE CAPTURING DEVICE OR SYSTEM

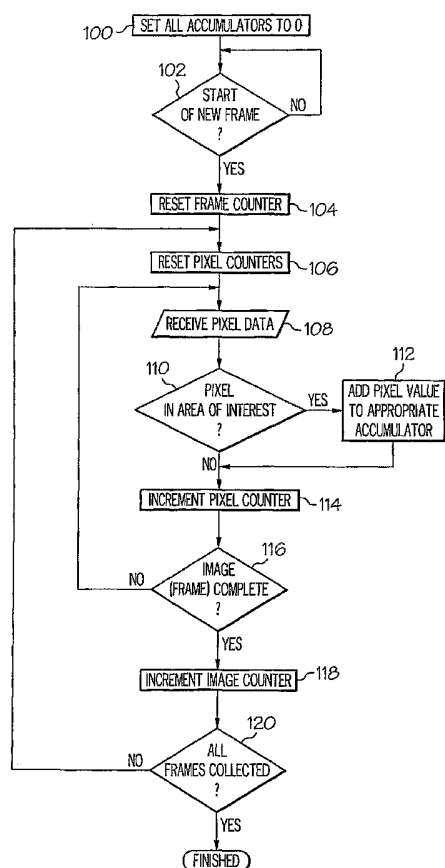

(57) Abstract: A method for providing an intensity or brightness measurement using a digital image-capturing device comprising: selecting a target area within a field of view of the image-capturing device, the target area containing pixels; measuring the intensity or brightness of pixels in a target area; accumulating the intensity or brightness values of the pixels in the target area; and determining a pixel value representative of the intensity or brightness of the pixels in the target area. A device for making color measurements comprising an image-capture device, a processor or logic device, and a memory location for accumulating color data, and the processor or logic device is programmed to perform color measurements by accumulating the data for pixels located in the target area in memory, and determining a representative color value.

WO 2005/114118 A1



(84) Designated States (*unless otherwise indicated, for every kind of regional protection available*): ARIPO (BW, GH, GM, KE, LS, MW, MZ, NA, SD, SL, SZ, TZ, UG, ZM, ZW), Eurasian (AM, AZ, BY, KG, KZ, MD, RU, TJ, TM), European (AT, BE, BG, CH, CY, CZ, DE, DK, EE, ES, FI, FR, GB, GR, HU, IE, IS, IT, LT, LU, MC, NL, PL, PT, RO, SE, SI, SK, TR), OAPI (BF, BJ, CF, CG, CI, CM, GA, GN, GQ, GW, ML, MR, NE, SN, TD, TG).

For two-letter codes and other abbreviations, refer to the "Guidance Notes on Codes and Abbreviations" appearing at the beginning of each regular issue of the PCT Gazette.

Published:

— *with international search report*

**METHOD FOR COLLECTING DATA FOR COLOR MEASUREMENTS
FROM A DIGITAL ELECTRONIC IMAGE CAPTURING DEVICE OR SYSTEM**

Cross-Reference to Related Applications

[0001] This application claims priority from U.S. Provisional Application No. 60/570,562 filed May 13, 2004 and from U.S. Provisional Application No. 60/570,563 filed May 13, 2004.

Field of the Invention

[0002] This invention is a method for collecting data from an electronic image-capturing device or system in a way that enables it to provide accurate and consistent information about the colors of one or more points or regions of the image. A color measurement device is also provided.

Background of the invention

[0003] Traditional methods for building a color measurement device typically involve high-precision optics, complex mirrors/prisms, sophisticated illumination systems, and/or specialized processing capabilities (e.g., low-noise analog-to-digital converters). The advent of the digital imaging chip – although intended to capture moving or still images – created an intriguing alternative “engine” for making a color measurement based on its simplicity and low cost.

[0004] However, digital imaging chips, when used as intended to capture images, are typically ineffective at making precise color measurements. This is due in part to the large amount of data generated by each image. This massive amount of data from the “raw” image must be compressed to increase their transmission rate and color information is typically lost in this process. For a color measurement at a specific point, only a fraction of the total image data is relevant anyway – the rest is superfluous. Finally, most imaging chips have built-in features that make automatic adjustments (e.g., of shutter width and sensitivity). These allow the chip to produce good images under a wide variety of conditions and in changing conditions. However these features become a barrier to an

accurate color measurement, as they can make the response of the chip to a color stimulus unpredictable. All of these factors combine with the fundamental instabilities and noise inherent in a typical analog-digital electronic system to limit an imaging chip's ability to make precise, accurate, and repeatable color measurement.

[0005] The purpose of this patent is to describe a method that overcomes these obstacles, and can make a digital imaging chip a viable means for making a color measurement.

Summary of the invention

[0006] An electronic image capture device or system (typically an imaging chip such as that used in a digital camera or the camera itself) is interfaced with a processor or logic device selected to have sufficient speed to process data generated by the imaging device/system on a pixel-by-pixel basis, and sufficient memory to accumulate data of interest. Regions of the image from which an accurate color reading is desired are defined by their x-y pixel coordinates (one or more "regions of interest"). As the image capture device or system streams out data from each pixel, the processor determines whether that pixel data is from a region of interest. If so, the value output from that pixel is placed in an accumulator dedicated to values from that area. This process is repeated over multiple images (frames), summing the new pixel values with the total of the previous pixel values in the accumulator(s). Once the desired number of pixel readings has been accumulated, the average pixel value is calculated by dividing the total by the number of values accumulated. In one embodiment, the data from the image capture device can be streamed into temporary memory, and the pixels of interest can be summed into the accumulators as a secondary operation. In one embodiment, for higher accuracy, the image capture device/system can be configured such that automatic adjustments and compensations are disabled, blanking is disabled, gain is minimized, integration time is maximized and focus is slightly blurred.

[0007] One embodiment of the invention is a color measurement system. An image capturing device with an array of red, green and blue sensors (i.e., R, G, and B pixels) and an appropriate lens/optical system is placed in an enclosure that provides a light-tight seal around a target area of which the color is to be measured, with such area in the field of

view of the imaging device/system. A region of interest is defined as some or all of the pixels in view of the target. The enclosure contains a stable light source that illuminates the target. Adding appropriate input/output and control capabilities, the device can accumulate data from the pixels in the region of interest over multiple images (frames). After the data are accumulated, a representative color value is determined to provide an accurate and consistent set of R, G and B values that can be used to identify the target color. In one embodiment the average pixel value is calculated. In other embodiments, additional mathematical operations may be performed to make further conversions and adjustments to the color readings. In another embodiment, as an alternative to calculating an average value, a median value can be determined.

[0008] One manifestation of the invention is a method for providing an intensity or brightness measurement using a digital image-capturing device comprising:

selecting a region of interest within the field of view of the image-capturing device, the region of interest containing pixels,

determining the brightness of pixels in the region of interest,

accumulating the brightness values of the pixels in the region of interest; and

determining a pixel value representative of the brightness of the pixels in the region of interest.

[0009] Another manifestation of the invention is the method as described above wherein the representative pixel value is the average value.

[0010] Another manifestation of the invention is the method as described first above wherein the representative pixel value is the median pixel value.

[0011] Another manifestation of the invention is the method for making a color measurement as described above wherein the region of interest contains three or more color-selective pixel types, such as red, green and blue pixels and the step of accumulating the brightness values includes individually accumulating brightness values for each of the red, green and blue pixels and the step of determining a representative pixel value includes determining a representative red, green and blue pixel value.

[0012] Another manifestation of the invention are the methods as described above wherein the step of accumulating the brightness values includes accumulating the brightness values for multiple image frames.

[0013] Another manifestation of the invention is the method as described above wherein the region of interest is at least 2 x 2 pixels and up to 100 x 100 pixels and more typically about 20 x 20 pixels. However the field of interest can be any shape include rectangular, hexagonal, diamond, circular, etc.

[0014] Another manifestation of the invention is the method as described about wherein the number of image frames is at least 3 and may range up to substantially any number but is typically 10 and still more typically five or less.

[0015] In another manifestation of the invention as described above, the image-capturing device is a digital camera or an image-capturing chip.

[0016] A measurement device in accordance with one embodiment of the invention has one or more of the following features:

[0017] (a) a surface structure containing the aperture through which the measurement will be made that provides a stable, fixed parallel orientation of the focal plane of the image – capturing device relative to the target plane;

[0018] (b) a contact surface is provided that surrounds the aperture and has sufficient area to enable that a light-tight seal is formed between the target area and the device;

[0019] (c) a recessed area, inset away from the target area by about 0.125" or greater is provided such that the measurement device does not contact the target in the immediate vicinity of where the measurement is to be made, but allows the outer perimeter of the device to form a light-tight contact surrounding the target.

[0020] In accordance with another manifestation of the invention, the measurement device includes an image-capture device and a processor or logic device and a memory location for accumulating color data such as RGB intensity or brightness data and the processor or logic device is programmed to perform the color measurements described herein.

Brief Description of the Drawings

[0021] Fig. 1 is a pair of photographs illustrating the selection of a target (dark) area for measurement in accordance with the invention.

[0022] Fig. 2 is a diagram illustrating the identification of pixels.

[0023] Fig. 3 is a flow chart illustration one non-limiting exemplary embodiment of the invention.

[0024] Fig. 4 is a perspective view of a front housing of an imaging device.

[0025] Fig. 5 is a perspective view of the back housing of an imaging device including the supporting circuitry.

Detailed Description*Operational Overview*

[0026] An electronic image capture device or system (typically an imaging chip such as that used in a digital camera or the camera itself) is typically designed to capture images as an array of red, green and blue pixels. The devices generate values proportional to the amount of light (of each color) that strikes each pixel. One image capture device that can be used in one embodiment is shown in Figs. 1 and 2. This device is particularly useful in making skin color measurements.

[0027] While the devices are typically used to capture an entire image, the data collection method described herein does not collect an image, but individual pixel data only for one or more points or regions of interest where a color measurement is desired. This invention in certain embodiments also provides a set of operating conditions for a digital imaging device that will enable the device/system to provide highly accurate and consistent color information.

[0028] An electronic image capture device/system is configured to capture an image such as those shown in Fig. 1. One or more regions of interest (as depicted by the dark square in the image on the right) is selected as the point at which a precise measurement of the color of the target is desired.

[0029] The size of the region of interest (captured as x pixels by y pixels) will vary with the optics used with the image capture device and the characteristics of the item being imaged. Typically an image capture device/system organizes its array of pixels in rows of Green and Red-sensitive pixels, alternating with rows of Blue and Green-sensitive pixels as described by Bayer, et al. in US patent 3,971,065. Therefore, the size of the region of interest must be at least 2×2 pixels to ensure that one pixel of each color sensitivity is included. In practice, a region of interest this small would not allow much pixel, however, and should be avoided. A larger area should be chosen to allow data from multiple pixels to be averaged together to eliminate the effect of any anomalies in the target (e.g., dust, scratches, smudges etc.). The region should not be so large, however, that the color of the target is not consistent throughout the region. In Fig. 1, if the region of interest is too large, it could include segments of the fence or roof which introduce a different color.

[0030] In practice, a region that includes 20×20 pixels has been found to be adequate. The region as shown is square, but in practice, the region may have any shape. Although not required, simplicity suggests selecting a region of interest with that is square, and has an equal number of red and blue pixels, and twice that number of green pixels.

[0031] The specific pixels in the region of interest must be identified, as shown in the illustration in Fig. 2, where the upper leftmost pixel in the region of interest is (x_1, y_1) and the lower rightmost pixel in the region of interest is (x_2, y_2) .

[0032] Memory locations are reserved for use as accumulators for pixels of each color in the region of interest. For a single region of interest, regardless of its size, three memory locations are typically used, one each for data from the red, blue, and green pixels in the regions. (Optionally, data from the green pixels can be accumulated in separate registers and combined later.) Care must be taken that each location is big enough to allow summing the data for that pixel color without overflow. So, for example, if each pixel provides an 8-bit number, the maximum value is 256. In a 20×20 array, there would be 100 red and blue pixels, and 200 green pixels. Therefore the red and blue accumulators must have capacity for a number up to 25600 (256×100) and the green accumulator for a number up to 51,200 (256×200) if all green data is to be summed in one accumulator. (Proportionally more capacity is required if more than one frame is to be used to allow additional averaging and further reduce the impact of noise, as discussed below.)

[0033] Alternatively, if desired, the pixel data may be temporarily stored in memory, and the process outlined in the preceding flowchart can be used to process those data and accumulate values for the regions of interest.

[0034] The minimum number of frames of data that may be considered is one. However, even in the most stable of conditions there will likely be externalities that cause short-term and long-term variance in the reported data. Short-term variabilities (e.g., electrical noise) can be reduced by averaging together multiple readings (frames) for each pixel/region. However, as more frames are collected, data-collection time increases, and long-term variabilities (e.g., electrical components heating up) may begin to de-stabilize the system and impact the readings. Collecting fewer readings (frames) and collecting them as quickly as possible will mitigate the influence of long-term externalities. Therefore, the number of frames must be selected to optimally balance between mitigating short-term and long-term variabilities. In practice, collecting data over 5 frames has been found to provide satisfactory results.

[0035] With the region of interest and the accumulators established, data can be collected using the process outlined in the flowchart in Fig. 3.

[0036] Before collecting the data for the color measurement for the target area, the accumulator memory locations are set to 0 as indicated at Step 100 in Fig. 3 and a determination is made regarding whether the data is for a new frame or an existing frame at Step 102. If the data relates to a new frame, the frame counter is set or reset at 104 and the pixel counters are reset at 106. The R, G, and B pixel data is received at Step 108. In this process, because data is available from pixels within and without the target area, each pixel is evaluated to determine whether it is within the pixel area of interest at 110. If the pixel is within the target area, the pixel R, G, and B values are added to the corresponding accumulator at 112 and the pixel counter is incremented at 114. If the pixel is not in the target area of interest, the pixel value is not added to the accumulator. If the frame is complete, the frame counter is increased at 118. Until then, the next pixel is analyzed and the data continues to be added to the accumulators at 112 as discussed above. When the frame is complete, the counter is incremented. When data for all of the frames has been collected at 120, the process is finished and the accumulator values are averaged. On the

other hand, if data for the predetermined number of frames has not been collected, the pixel counters are reset at 106 to receive pixel data for the next frame.

[0037] When the desired number of frames have been processed, all that remains is to divide to compute an average value. The divisor is the number of frames of data collected times the number of pixels in the region of interest of that color. So, with 5 frames of a 20x20 region of interest the divisor would be 500 for the red and blue pixels and 1000 for the green pixels.

[0038] The process outlined above will accumulate pixel data and average out the effects of random noise, imperfections in the image, and irregularities in the imager. However, image capture devices typically include features that allow them to automatically adapt to a variety of environments (e.g., different lighting conditions) and while this contributes to their versatility and usually results in a pleasing image overall, it creates significant variation in the values generated from the pixels of each color.

[0039] Therefore, to collect accurate, consistent color information based on pixel data from a point or region of the image, it is desirable to disable and/or preset one or more of the automatic functions and operate the device in a reasonably fixed, stable state that is conditions that is optimized for color measurement.

[0040] Each of these settings is discussed below. Not all imaging devices/systems may allow access to all of the settings as described, and that while the described settings tend to optimize performance, generally any setting may be chosen.

[0041] Gain. It is desirable to set gain to the lowest possible value to reduce noise, but high enough that the device is just below saturation when presented with the brightest possible image to use its full dynamic range. This can be accomplished by presenting an all white target to the device/system. With an 8 bit device, for example, it would be desirable to set the gain such that the pixel values are near their saturation value of 255. The gain setting will depend on shutter width (see below).

[0042] Shutter Width/Integration time. Shutter width (also sometimes referred to as integration time) should be set to the highest possible value, but, like gain, just below the value at which any pixel saturates when presented with the brightest possible image.

[0043] In practice, because settings for shutter width and gain depend on each other, one method by which values can be determined is to set the gain at unity (1) for each channel (R, G and B), and then, with the references and target all changed to white, increase the shutter width until one of the pixel accumulators reaches saturation. (This value must be calculated based on the maximum value that a pixel can return, the number of pixels the accumulator contains, and the number of frames taken.) If none saturate when the shutter width reaches its limit, repeat the process with a slightly higher gain. Continue until at least one channel saturates. Having established the maximum shutter width and the gain for one channel in this way, the gains for the remaining channels can be increased while keeping the shutter width constant until they, too, are equal or nearly equal (keeping the references and target white) and near their saturation point.

[0044] Blanking. Both horizontal and vertical blanking should be set to zero to maximize imager speed, assuming that the chosen processor can perform the necessary operations without any built in delays and that the light source in use is not operating at a frequency that could affect the capture of the image.

[0045] Focus. Focus on the target should be slightly blurred. This will still allow good recognition of the target color, but will mask any small imperfections such as dust or scratches.

[0046] Black compensation. Black compensation should be disabled. This prevents the imaging device/system from attempting to adjust or “normalize” the output of the device, which is generally desired when capturing a full image, but distorts the data when attempting to do an accurate measurement of color.

[0047] Compression. All compression algorithms (e.g., jpeg) should be turned off to avoid loss of data.

[0048] Although any color digital image capture device may be used, in a particular embodiment the device is a CMOS imaging chip with at least 240 X 320 resolution, and an analog-to-digital converter that produces at least 8 bit results from each pixel. Ideally, the “raw” data from the chip should be accessible without compression or additional processing other than the digital-to-analog conversion.

[0049] Processor speed is of paramount performance. The faster the pixel data can be accumulated, the more that longer-term environmental variations (like temperature or illumination changes) can be avoided, and the less likely it will be to “miss” pixels. A processor should be chosen that can perform the necessary operations on data from each pixel before data from the next pixel arrives. One effective technique is use of an FPGA (Field Programmable Gate Array) which, due to its relative simplicity, is inherently fast.

[0050] Steady illumination is critical to the performance of the imaging device/system, and for small targets in a confined enclosure, white LEDs, driven by a constant DC current source have proven to be one method of providing effective illumination.

[0051] Although many configurations are possible, these items may be designed onto a circuit board and placed into a compact enclosure (along with the necessary power, control, and user interface circuitry) as shown in Exhibit 1 to make a small, hand-held device that can illuminate a target and measure its color.

[0052] The method of the invention, in one embodiment, can be implemented using the hand held shown in Figs. 4 and 5.

[0053] Processor speed is of paramount performance. The faster the pixel data can be accumulated, the more that longer-term environmental variations (like temperature or illumination changes) can be avoided, and the less likely it will be to “miss” pixels. A processor should be chosen that can perform the necessary operations on data from each pixel before data from the next pixel arrives. One effective technique is use of an FPGA (Field Programmable Gate Array) which, due to its relative simplicity, is inherently fast.

[0054] Steady illumination is critical to the performance of the imaging device/system, and for small targets in a confined enclosure, white LEDs, driven by a constant DC current source have proven to be one method of providing effective illumination.

[0055] Although many configurations are possible, these items may be designed onto a circuit board and placed into a compact enclosure (along with the necessary power, control, and user interface circuitry) as shown in Exhibit 1 to make a small, hand-held device that can illuminate a target and measure its color.

[0056] The method of the invention, in one embodiment, is implemented using the hand held device illustrated in Figs 4 and 5.

[0057] The device illustrated front housing 10 shown in Fig. 4 is elliptical in shape, although other overall shapes are possible, with a major axis of roughly 3.75 inch and a minor axis of 2.25 inch. This configuration has the added advantage of being compact enough and ergonomically convenient to be easily hand held.

[0058] The side 12 of this device that is placed against the target area, e.g., the skin, to make measurements is sufficiently flat to provide a light tight seal, with the aperture 14 through which the color measurement is taken typically in its center. The aperture in this particular case is square, measuring 0.2 inch on a side but the shape of the aperture and its size can vary. In the method described above, the target area (e.g., the dark area in the right-hand photo in Fig. 1 may correspond to all or a portion of the area of the aperture 14.

[0059] Concentrically surrounding the aperture is an elliptically-shaped recess 16. The major axis of this recessed area is 1.5 inch. The minor axis is 1.25 inch, and it is recessed 0.125 inch from the surface of the ellipse in a direction away from the target to provide a stable, fixed orientation in which the target and the focal plane of the chip are in spaced parallel planes. Again the exact shape of the recess is not particularly critical. What is important is that the recess is surrounded by a contact surface 18 that enables a light tight seal to be formed around the target area. The recessed area preferably has a surface area large enough that the measurement aperture can be located such that a boundary of at least 0.5 inch exists between the outer perimeter of the measurement aperture to the edge of the recessed area in all directions. A recessed area, inset away from the target area by about 0.125 inch or greater is provided such that the measurement device does not contact the target in the immediate vicinity of where the measurement is to be made, but allows the outer perimeter of the device to form a light-tight contact surrounding the target. The contact surface surrounds the aperture and has sufficient area to enable that a light-tight seal is formed between the target area and the device. In one embodiment, the contact surface should be at least about 0.25 inch wide. The device also presents a generally fixed and reproducible distance between the target area and the focal plane of the image-capturing device such as a charge coupled device or imaging chip (not seen) that is provided on a circuit board 22 in the back housing 24. The housing containing the aperture

through which the measurement will be made that provides a stable, fixed parallel orientation of the focal plane of the image-capturing device relative to the target plane. In a particular embodiment, the imaging chip is a model MI-0133, a 1/7 inch CMOS 377H x 312V sensor, commercially available from Micron Technology and the device includes a lens 25 and two white LED's 26 as an internal source to illuminate the target area. In this embodiment, two LED's are used to provide the desired illumination intensity. One or more LED's can be used for this purpose depending on the characteristics of the LED and the target area the device may be designed.

[0060] These dimensions are preferably optimized such that an area of skin or other target can be measured for color without creating distortion or discoloring. The surfaces 18 that contact the skin are sufficiently distant from the measurement aperture 14, minimizing color distortion at the point of measurement, and simultaneously preventing entry of ambient light by making positive contact with the skin.

[0061] To make readings of skin color, the device in this configuration is held gently against the skin at one or several locations. The device is held flat on the surface of the skin with sufficient pressure to seal out ambient light, but not so much pressure that the recessed area contacts the skin and cause discoloration (by effecting blood flow to the area, or any other cause). Electronics inside the device can then illuminate the skin and through appropriate optics, electronic sensors can analyze the reflected light to determine skin color.

[0062] Having described the invention in detail and by reference to specific embodiments thereof, it will be apparent that numerous variations and modifications are possible including without departing from the invention as defined by the following claims.

What is claimed is:

Claims

1. A method for providing an intensity or brightness measurement using a digital image-capturing device comprising:
 - selecting a target area within a field of view of the image-capturing device, the target area containing pixels,
 - measuring the intensity or brightness of pixels in a target area,
 - accumulating the intensity or brightness values of the pixels in the target area;
 - and
 - determining a pixel value representative of the intensity or brightness of the pixels in the target area.
2. The method of Claim 1 wherein the representative pixel value is an average value.
3. The method of Claim 1 wherein the representative pixel value is a median pixel value.
4. The method of Claim 1 wherein the target area contains three or more color-selective pixel types and the step of accumulating the intensity or brightness values includes individually accumulating intensity or brightness values for each of the pixel types and the step of determining a representative pixel value includes determining a representative pixel value for each pixel type.
5. The method of Claim 4 wherein the pixel types include red, green and blue pixels respectively.
6. The method of Claim 4 wherein the step of accumulating the intensity or brightness values includes accumulating the intensity or brightness values for multiple image frames.
7. The method of Claim 6 wherein the region of interest is at least 2 x 2 pixels and up to 100 x 100 pixels.
8. The method of Claim 7 wherein the number of image frames is at least 3.

9. The method of Claim 1 wherein the image-capturing device is a digital camera or an image-capturing chip.
10. The method of Claim 9 wherein the image-capturing device includes a gain and the method includes the step of setting the gain to a level sufficient to reduce noise but high enough that the device is below saturation when presented with the brightest possible image.
11. The method of Claim 9 wherein the image-capturing device includes a shutter width and the method includes the step of setting the shutter width to the highest possible value, but just below the value at which any pixel saturates when presented with the brightest possible image.
12. The method of Claim 9 wherein the image-capturing device includes a focus and the method includes the step of blurring the image to mask imperfections but permit good recognition of the target color.
13. The method of Claim 8 wherein the image-capturing device is a CMOS imaging chip.
14. A device for measuring the color of a target area comprising:
a housing and an image-capturing device having a focal plane,
the housing having a first surface having an aperture therein defining a target plane through which the color measurement is made,
the surface and the housing providing a stable, fixed parallel orientation of the focal plane of the image-capturing device relative to the target plane.
15. The device of Claim 14 wherein the first surface includes a contact surface that surrounds the aperture and has sufficient area that a light-tight seal is formed between the target area and the contact surface.
16. The device of Claim 15 wherein the first surface also includes a recessed area, inset from the target area such that the measurement device does not contact the target area in

the immediate vicinity of the aperture and the contact surface forms a light-tight contact surrounding the target area.

17. The device of Claim 15 wherein, but for the aperture, the housing is light-tight and the housing includes at least one light source for making color measurements of the target area through the aperture.

18. The device of Claim 17 wherein the image-capturing device is a CMOS imaging chip.

19. The device of Claim 18 wherein the device fits in the palm of the hand.

20. The device of Claim 14 wherein the device includes a processor or logic device and a memory location for accumulating color data and the processor or logic device is programmed to perform color measurements by accumulating the data for pixels in the target area and determining a representative color value.

21. A device for making color measurements comprising an image-capture device, a processor or logic device, and a memory location for accumulating color data, and the processor or logic device is programmed to perform color measurements by accumulating the data for pixels located in the target area in memory, and determining a representative color value.

22. The device of Claim 21 wherein the processor or logic device is programmed to perform the steps of:

measuring the brightness of pixels in a target area,

accumulating the brightness values of the pixels in the target area; and

determining a pixel value representative of the brightness of the pixels a the target area.

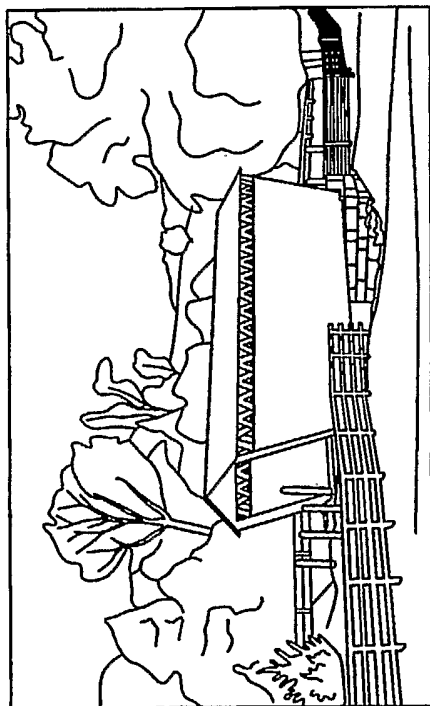
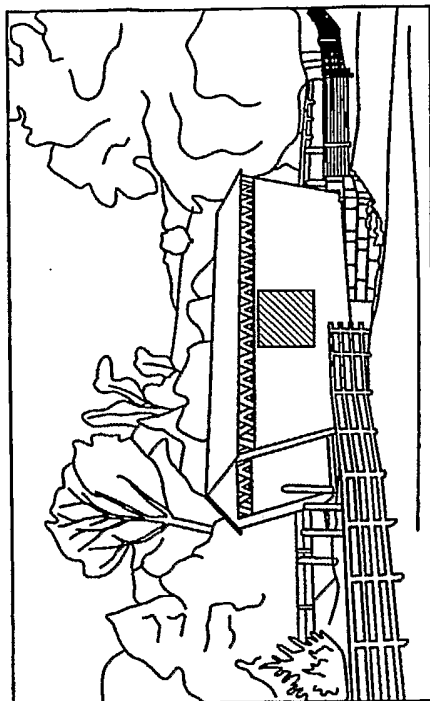

FIG. 1

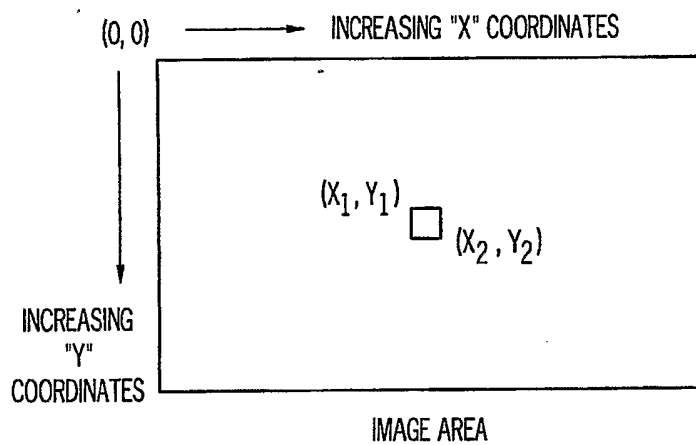

FIG. 2

3 / 4

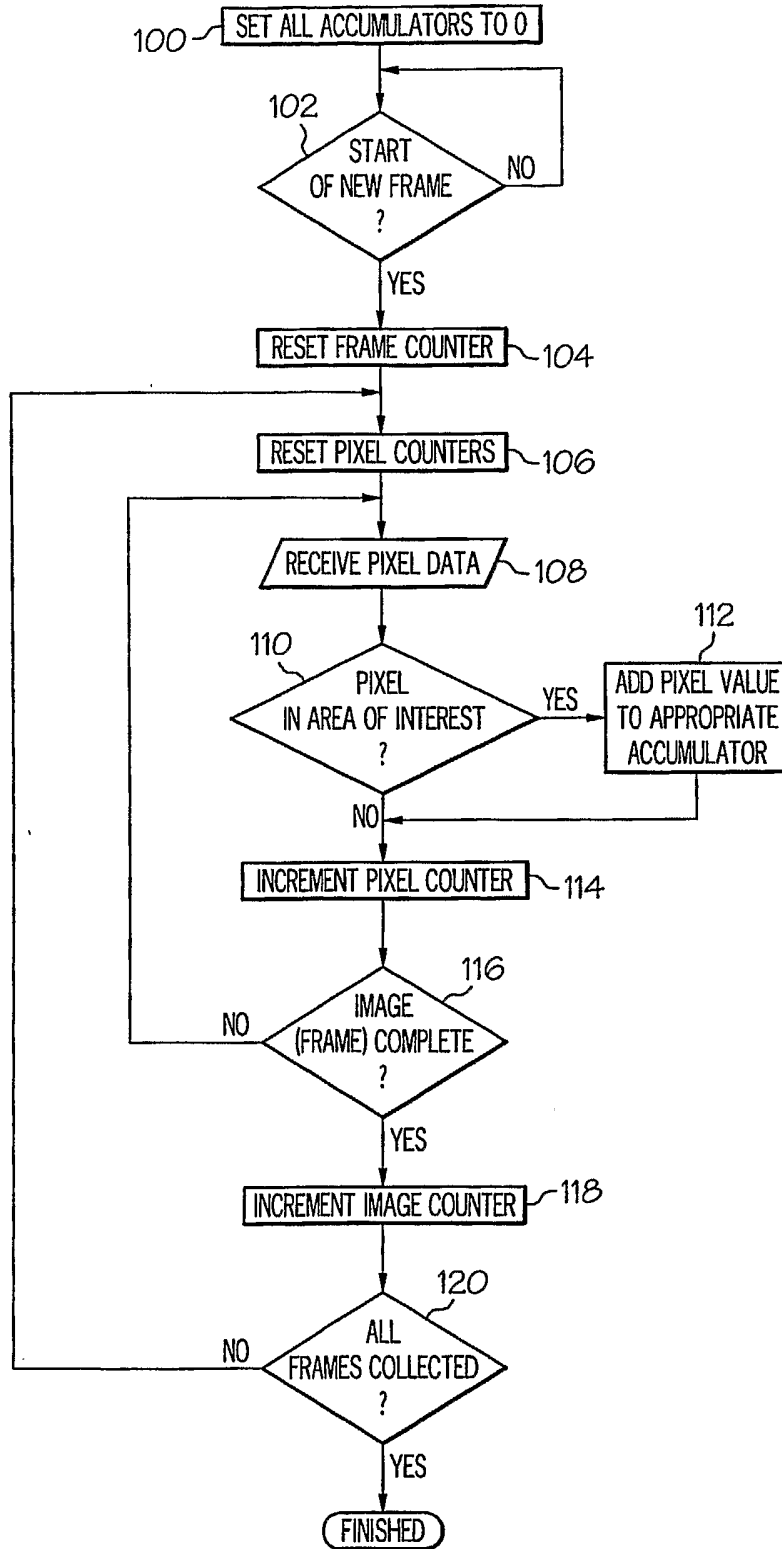

FIG. 3

4 / 4

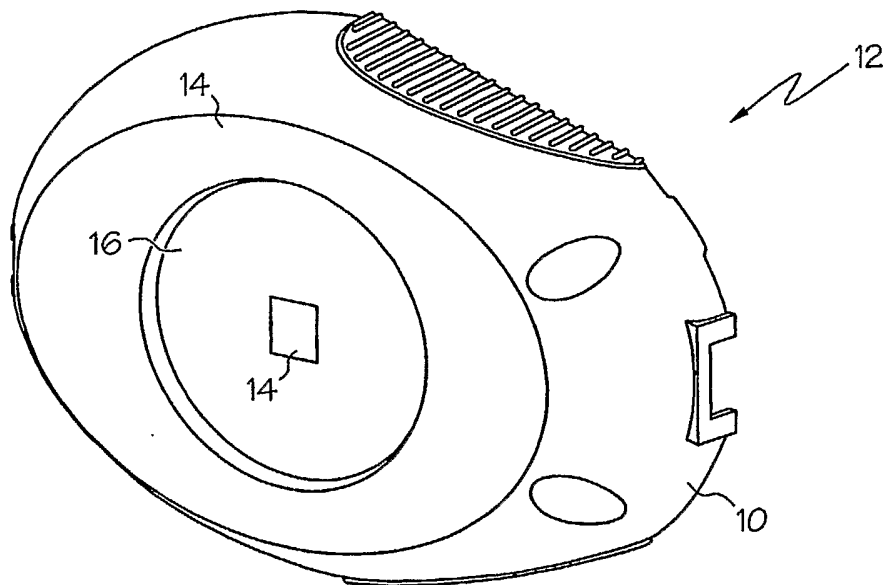

FIG. 4

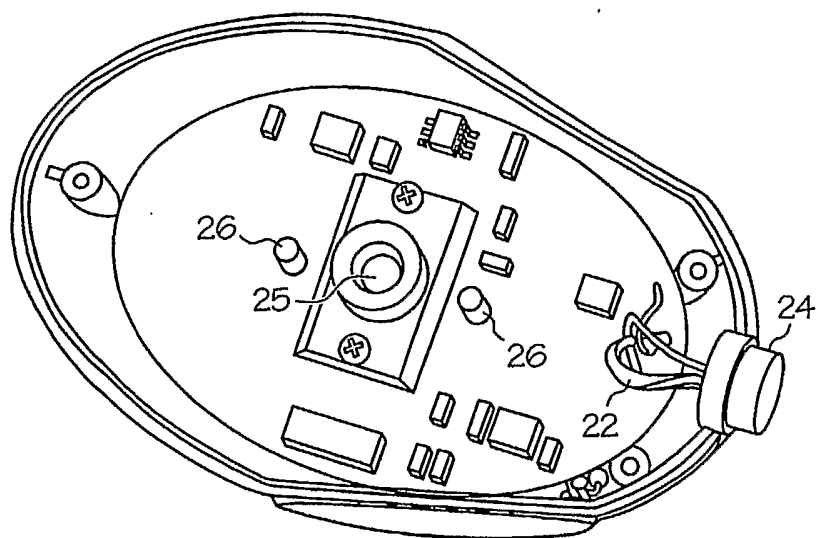

FIG. 5

INTERNATIONAL SEARCH REPORT

International Application No
PCT/US2005/016722

A. CLASSIFICATION OF SUBJECT MATTER IPC 7 G01J3/46				
According to International Patent Classification (IPC) or to both national classification and IPC				
B. FIELDS SEARCHED				
Minimum documentation searched (classification system followed by classification symbols) IPC 7 H04N G01J				
Documentation searched other than minimum documentation to the extent that such documents are included in the fields searched				
Electronic data base consulted during the international search (name of data base and, where practical, search terms used) EPO-Internal				
C. DOCUMENTS CONSIDERED TO BE RELEVANT				
Category °	Citation of document, with indication, where appropriate, of the relevant passages	Relevant to claim No.		
X	WO 2004/018984 A (KONINKLIJKE PHILIPS ELECTRONICS N.V; SIMONS, PAUL, R; MCPHERSON, DUNCA) 4 March 2004 (2004-03-04) abstract page 3, line 5 - line 10 page 9, line 2 - line 12	1,2,4,5, 9,21,22		
X	US 5 850 472 A (ALSTON ET AL) 15 December 1998 (1998-12-15) abstract; claims 1,26 column 14, line 1 - column 15, line 21 ----- -/--	1,2,4,5, 9-11,21, 22		
<input checked="" type="checkbox"/> Further documents are listed in the continuation of box C.				
<input checked="" type="checkbox"/> Patent family members are listed in annex.				
° Special categories of cited documents :				
<table style="width: 100%; border: none;"> <tr> <td style="width: 50%; border: none; vertical-align: top;"> "A" document defining the general state of the art which is not considered to be of particular relevance "E" earlier document but published on or after the international filing date "L" document which may throw doubts on priority claim(s) or which is cited to establish the publication date of another citation or other special reason (as specified) "O" document referring to an oral disclosure, use, exhibition or other means "P" document published prior to the international filing date but later than the priority date claimed </td> <td style="width: 50%; border: none; vertical-align: top;"> "T" later document published after the international filing date or priority date and not in conflict with the application but cited to understand the principle or theory underlying the invention "X" document of particular relevance; the claimed invention cannot be considered novel or cannot be considered to involve an inventive step when the document is taken alone "Y" document of particular relevance; the claimed invention cannot be considered to involve an inventive step when the document is combined with one or more other such documents, such combination being obvious to a person skilled in the art. "&" document member of the same patent family </td> </tr> </table>			"A" document defining the general state of the art which is not considered to be of particular relevance "E" earlier document but published on or after the international filing date "L" document which may throw doubts on priority claim(s) or which is cited to establish the publication date of another citation or other special reason (as specified) "O" document referring to an oral disclosure, use, exhibition or other means "P" document published prior to the international filing date but later than the priority date claimed	"T" later document published after the international filing date or priority date and not in conflict with the application but cited to understand the principle or theory underlying the invention "X" document of particular relevance; the claimed invention cannot be considered novel or cannot be considered to involve an inventive step when the document is taken alone "Y" document of particular relevance; the claimed invention cannot be considered to involve an inventive step when the document is combined with one or more other such documents, such combination being obvious to a person skilled in the art. "&" document member of the same patent family
"A" document defining the general state of the art which is not considered to be of particular relevance "E" earlier document but published on or after the international filing date "L" document which may throw doubts on priority claim(s) or which is cited to establish the publication date of another citation or other special reason (as specified) "O" document referring to an oral disclosure, use, exhibition or other means "P" document published prior to the international filing date but later than the priority date claimed	"T" later document published after the international filing date or priority date and not in conflict with the application but cited to understand the principle or theory underlying the invention "X" document of particular relevance; the claimed invention cannot be considered novel or cannot be considered to involve an inventive step when the document is taken alone "Y" document of particular relevance; the claimed invention cannot be considered to involve an inventive step when the document is combined with one or more other such documents, such combination being obvious to a person skilled in the art. "&" document member of the same patent family			
Date of the actual completion of the international search <p style="text-align: center; font-size: 1.2em;">23 August 2005</p>		Date of mailing of the international search report <p style="text-align: center; font-size: 1.2em;">01/09/2005</p>		
Name and mailing address of the ISA European Patent Office, P.B. 5818 Patentlaan 2 NL - 2280 HV Rijswijk Tel. (+31-70) 340-2040, Tx. 31 651 epo nl, Fax: (+31-70) 340-3016		Authorized officer <p style="text-align: center; font-size: 1.2em;">Güvener, C</p>		

INTERNATIONAL SEARCH REPORT

 Application No
 PCT/US2005/016722

C.(Continuation) DOCUMENTS CONSIDERED TO BE RELEVANT		
Category	Citation of document, with indication, where appropriate, of the relevant passages	Relevant to claim No.
X	US 2002/012895 A1 (LEHMANN MARYANN) 31 January 2002 (2002-01-31) abstract; figures 6,8,10 paragraphs '0046!, '0047!, '0061!, '0099!	1,2,4,5, 9,21,22
A	US 6 525 819 B1 (DELAFTER S. BRETT ET AL) 25 February 2003 (2003-02-25) column 9, line 48 - line 52	3
A	US 6 205 243 B1 (MIGDAL ALEXANDER A ET AL) 20 March 2001 (2001-03-20) column 23, line 51 - column 24, line 61	6-8
A	US 5 526 285 A (CAMPO ET AL) 11 June 1996 (1996-06-11) column 4, line 66 - column 5, line 5	12
A	US 2003/076498 A1 (PFISTER BRUNO) 24 April 2003 (2003-04-24) abstract paragraph '0020!	1,14,21
X	US 6 369 895 B1 (KEENEY RICHARD A) 9 April 2002 (2002-04-09) abstract; figures 3,6-10 column 4, line 14 - column 7, line 20	14-20
A	US 2003/071998 A1 (KRUPKA F. JEFFREY ET AL) 17 April 2003 (2003-04-17) abstract; figures 1-3 paragraphs '0048!, '0051! - '0056!	14-20
A	DE 196 33 557 A1 (TECHKON ELEKTRONIK GMBH, 61462 KOENIGSTEIN, DE) 5 March 1998 (1998-03-05) abstract column 3, line 54 - column 5, line 24	14-20

INTERNATIONAL SEARCH REPORT

Information on patent family members

Inter	Application No
PCT/US2005/016722	

Patent document cited in search report	A	Publication date	Patent family member(s)	Publication date
WO 2004018984	A	04-03-2004	AU 2003250454 A1	11-03-2004
			EP 1532427 A1	25-05-2005
			WO 2004018984 A1	04-03-2004
US 5850472	A	15-12-1998	NONE	
US 2002012895	A1	31-01-2002	US 6305933 B1	23-10-2001
			US 6132210 A	17-10-2000
			US 5961324 A	05-10-1999
			US 5766006 A	16-06-1998
			US 2005118549 A1	02-06-2005
			US 2002064751 A1	30-05-2002
			US 2003190578 A1	09-10-2003
			US 6206691 B1	27-03-2001
			US 6210159 B1	03-04-2001
			AU 6171296 A	30-01-1997
			WO 9701308 A1	16-01-1997
US 6525819	B1	25-02-2003	AU 5802999 A	21-03-2000
			AU 6242199 A	03-04-2000
			WO 0016045 A1	23-03-2000
			WO 0012020 A1	09-03-2000
			US 6157454 A	05-12-2000
US 6205243	B1	20-03-2001	US 6044170 A	28-03-2000
			AT 269623 T	15-07-2004
			AU 2597197 A	10-10-1997
			CA 2249451 A1	25-09-1997
			DE 69729555 D1	22-07-2004
			EP 0888693 A1	07-01-1999
			WO 9735439 A1	25-09-1997
			US 5995650 A	30-11-1999
			ZA 9702205 A	17-09-1997
US 5526285	A	11-06-1996	NONE	
US 2003076498	A1	24-04-2003	EP 1304553 A1	23-04-2003
			CA 2408466 A1	19-04-2003
US 6369895	B1	09-04-2002	AU 3128001 A	27-08-2001
			EP 1257795 A1	20-11-2002
			WO 0161294 A1	23-08-2001
US 2003071998	A1	17-04-2003	NONE	
DE 19633557	A1	05-03-1998	NONE	