

Jan. 14, 1969

P. PIATKOWSKI

3,421,420

VIBRATORY ROAD ROLLER WITH STEERING ARRANGEMENT

Filed Feb. 20, 1967

Sheet 1 of 2

FIG. 1

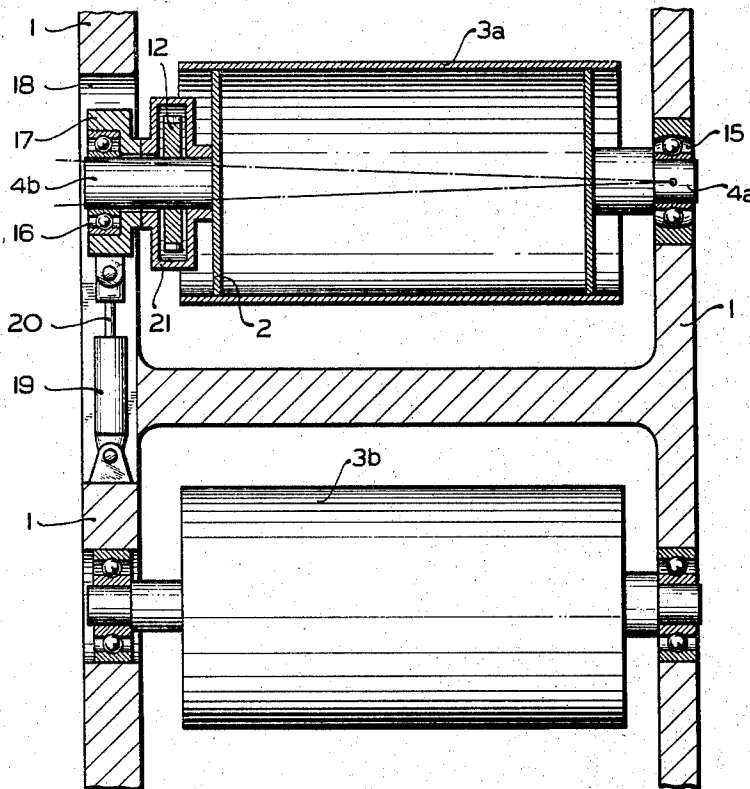

INVENTOR

Paul Piatkowski

*By Michael S. Stiker
Attorney*

Jan. 14, 1969

P. PIATKOWSKI

3,421,420

VIBRATORY ROAD ROLLER WITH STEERING ARRANGEMENT

Filed Feb. 20, 1967

Sheet 2 of 2

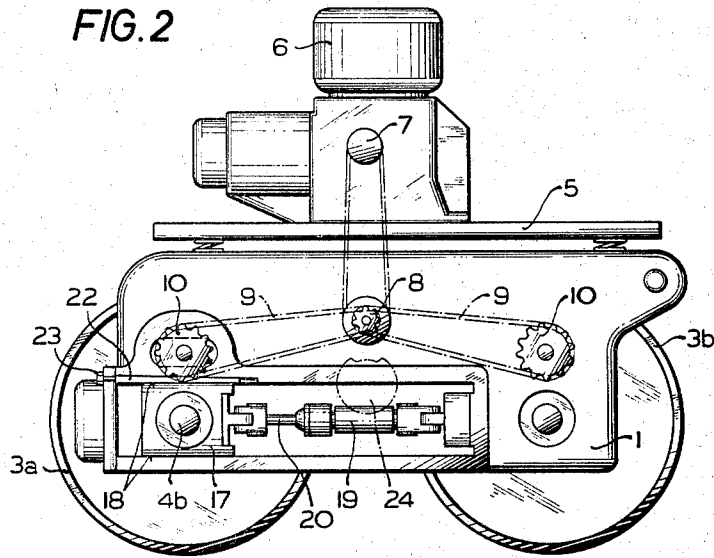
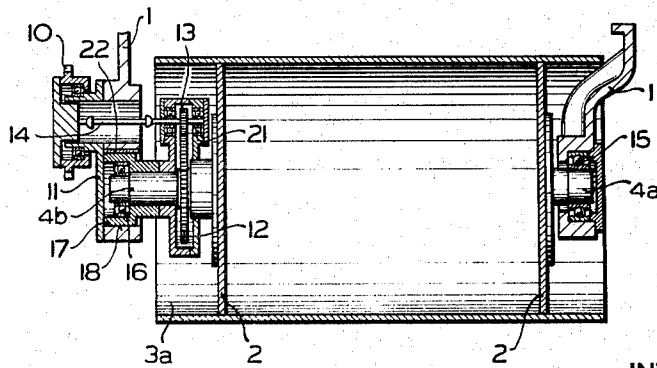

FIG. 3



INVENTOR

Poul Piatkowski
by Michael S. Striker
Attorney

1

3,421,420

VIBRATORY ROAD ROLLER WITH STEERING ARRANGEMENT

Paul Piatkowski, Kiel, Germany, assignor to Maschinenfabrik Buckau R. Wolf Aktiengesellschaft, Grevenbroich, Germany

Filed Feb. 20, 1967, Ser. No. 617,242

Claims priority, application Germany, Feb. 23, 1966, M 68,496

U.S. Cl. 94—50
Int. Cl. E01c 19/26

9 Claims

ABSTRACT OF THE DISCLOSURE

A vibratory road roller including a frame and a pair of spaced rollers turnably mounted in bearings carried by the frame. The bearings of at least one roller are mounted on the frame so that one of the bearings is turnable about a substantially vertical tilting axis and the other movable in a plane normal to the tilting axis. The road roller includes further means for moving the movable bearing in the aforementioned plane to tilt thereby the axis of said one roller about the aforementioned tilting axis for steering the road roller along curves.

BACKGROUND OF THE INVENTION

The present invention relates to a steering arrangement for a vibratory road roller having two driven rollers arranged spaced from each other in direction of movement of the road roller and each mounted turnably about its axis in a common frame.

The steering of road rollers of the aforementioned kind is connected with considerable difficulties. A steering arrangement is known in which each of the road rollers is divided in axial direction into two parts and in which the drive means for the rollers are connected to the two parts and constructed in such a manner that the two roller parts may be driven with different circumferential speeds. This known steering arrangement is relatively complicated and therefore expensive to manufacture. In addition, driving the two roller parts with different speeds during steering of the road roller along curves may lead to damaging of the road cover to be rolled.

Another steering arrangement is also known in which the frame, in which the two rollers are turnably mounted, is divided into two parts which are linked together so that the two frame parts may be tilted relative to each other about a vertical tilting axis during steering of the road roller along curves. This arrangement requires a complicated frame and this arrangement complicates also the drive of the two rollers.

It is an object of the present invention to provide for a steering arrangement for a road roller of the aforementioned kind which avoids the disadvantages of such arrangements known in the art.

It is an additional object of the present invention to provide for a steering arrangement for a road roller which is of relatively simple construction and which will stand up perfectly under extended use.

2

SUMMARY OF THE INVENTION

With these objects in view, the road roller according to the present invention mainly comprises support means, a pair of rollers carried spaced from each other in direction transverse to the axes thereof on the support means, a pair of bearing means for each of the rollers and mounting each roller in the region of opposite ends thereof turnable about its axis on the support means, one of the bearing means of at least one roller being mounted in the support means tiltable about a substantially vertical tilting axis, and means mounting the other bearing means of the one roller in the support means movable in a plane substantially normal to the tilting axis, drive means carried by the support means and connected at least to one of the rollers for rotating the same about its axis, and operating means connected to the other bearing means of the one roller for tilting the same about the aforementioned tilting axis so as to steer the road roller.

The aforementioned support means preferably comprise an elongated rigid frame carrying the rollers spaced from each other and the aforementioned operating means are preferably connected to the mounting means mounting the other bearing means of the one roller for moving the other bearing means in the aforementioned plane to tilt thereby the axis of the one roller about the aforementioned tilting axis. The mounting means preferably comprise guide means formed in the rigid frame and a slide member guided in the guide means and carrying the other bearing means of the one roller.

When the road roller is a vibratory road roller and includes an unbalance driven by the drive means, the difficulty arises that the slide member is subjected to continuous vibrations tending to lift the face of the slide member from the corresponding face of the guide means in rhythm with the sequence of the vibrations so that the danger exists that the co-operating faces of slide member and guide means are subjected to considerable wear, which, in relatively short time, may lead to a destruction of the slide faces.

To avoid such excessive wear, the arrangement preferably includes biasing means co-operating with the slide member and biasing the same in engagement with the guide means with a force greater than the force imparted by the unbalancing means to the slide member.

According to a further feature of the present invention each of the rollers comprises shaft means having opposite end portions respectively turnably mounted in the aforementioned bearing means and the drive means comprises a gear fixedly mounted on that end portion of the shaft means of the one roller which is mounted in the aforementioned other bearing means, a drive pinion meshing with the gear and a housing turnably mounting the drive pinion and connected to the slide member.

BRIEF DESCRIPTION OF THE DRAWING

FIG. 1 is a sectional view of the road roller according to the present invention, the section being taken substantially in a plane passing through the axes of the two rollers;

FIG. 2 is a side view of the road roller according to the present invention drawn to a slightly smaller scale than FIG. 1; and

FIG. 3 is a vertical section taken along the axis of the left roller, as viewed in FIG. 2.

DESCRIPTION OF THE PREFERRED EMBODIMENT

Referring now to the drawings, it will be seen that the road roller according to the present invention comprises support means in the form of a frame 1, of a cross-section as best shown in FIG. 1, in which a pair of rollers 3a and 3b are carried spaced from each other in direction transverse to the axes thereof. Each of the rollers 3a and 3b includes a pair of inwardly displaced end walls 2 fixed to the peripheral wall of the roller in any convenient manner, for instance by welding, and shaft means including a pair of stud shafts 4a and 4b fixed to the end walls 2, for instance by welding, and projecting outwardly therefrom coaxial with the peripheral surface of the roller, as best shown in FIG. 1 for the roller 3a. The frame 1 carries in a known manner a plate 5 resiliently supported on springs, on which a motor 6 provided with a speed reducer is mounted. The drive shaft 7 of the speed reducer is connected by means of a drive chain to a double-sprocket wheel 8 from which the drive is transmitted by means of chain drives 9 to sprocket wheels 10 respectively provided for the rollers 3a and 3b and each turnably mounted on a portion 11 of the frame 1, as best shown in FIG. 3 for the roller 3a.

The stud shaft 4b carries fixedly connected thereto a gear 12 meshing with a pinion 13, and a Cardan shaft 14 connects the sprocket wheel 10 with the pinion 13, as best shown in FIG. 3 for the roller 3a. The roller 3b may be driven from the respective sprocket wheel in the same manner.

According to the present invention, the stud shaft 4a of the roller 3a is mounted in a roller bearing 15, as best shown in FIG. 1, the inner race of which is tiltable about a substantially vertical tilting axis indicated by the small circle in the region of the end of the stud shaft 4a in FIG. 1, whereas the roller bearing 16 for the opposite stud shaft 4b of the roller 3a is mounted in a slide member 17 guided in guide means 18, best shown in FIG. 2, for movement in a substantially horizontal plane. Operating means are connected to the slide member 17 for moving the same in the aforementioned plane in the guide means 18. The operating means may be constituted by hydraulic cylinder and piston means, the piston rod 20 of which is pivotally connected at the free end thereof to one end of the slide member 17, whereas the cylinder 19 is pivotally connected at one end thereof to the frame 1, as best shown in FIG. 2. A bearing housing 21 is fixedly connected to the slide member 17 and the pinion 13 is turnably mounted in the bearing housing 21. When pressure fluid is fed into the hydraulic cylinder 19, from a source not illustrated in the drawing, so that the piston rod 20 will be moved toward the left, as viewed in FIG. 2, the axis of the roller 3a will be tilted about the tilting axis of the roller bearing 15 to a position inclined to the axis of the roller 3b, as schematically indicated by the dash-dotted line in FIG. 1, whereby the road roller is steered along a curve.

The road roller is preferably a vibratory road roller provided with an unbalance 24 located between the rollers 3a and 3b, as schematically indicated in FIG. 2, and driven in any convenient manner, not shown in the drawing, from the drive motor 6 to subject during rotation thereof the road roller to vibrations.

In order to prevent that the co-operating faces of the slide members 17 and the guide means 18 are prematurely destroyed due to the vibrations the road roller is subjected to, biasing means, which may be in the form of a wedge-shaped plate 22 are provided, for instance, between the top face of the slide member 17 and the face of the guide means 18 co-operating therewith, which wedge-shaped plate 22 is adjustable in longitudinal direction by means of an adjusting screw 23 so as to press the

bottom face of the slide member 17 against the corresponding face of the guide means 18 with a force greater than the vibrating force provided by the unbalancing means 24.

Since the housing 21 turnably carrying the pinion 13 is connected to the slide member 17, the position of the pinion will be adjusted during adjusting of the wedge shaped plate 22 so that the pinion 13 will remain in constant mesh with the gear 12.

It will be understood that each of the elements described above, or two or more together, may also find a useful application in other types of road rollers differing from the types described above.

While the invention has been illustrated and described as embodied in a vibratory road roller with a steering arrangement, it is not intended to be limited to the details shown, since various modifications and structural changes may be made without departing in any way from the spirit of the present invention.

Without further analysis, the foregoing will so fully reveal the gist of the present invention that others can by applying current knowledge readily adapt it for various applications without omitting features that, from the standpoint of prior art, fairly constitute essential characteristics of the generic or specific aspects of this invention and, therefore, such adaptations should and are intended to be comprehended within the meaning and range of equivalence of the following claims.

What is claimed as new and desired to be protected by Letters Patent is set forth in the appended claims.

I claim:

1. A steerable road roller comprising, in combination, support means; a pair of rollers carried spaced from each other in direction transverse to the axes thereof on said support means; shaft means for each roller coaxially arranged therewith and fixedly connected thereto; a pair of bearing means for each roller and mounting the shaft means of the respective roller in the region of opposite ends thereof turnably about its axis; steering means for steering said road roller, said steering means comprising means mounting one of the bearing means of at least one of said rollers tiltable about substantially vertical tilting axis, means mounting the other bearing means of said one roller on said support means movable in a plane substantially normal to said tilting axis, and operating means connected to said other bearing means for moving the latter in said plane for tilting thereby the shaft means of said one roller and the latter fixedly connected to said shaft means about said tilting axis to thereby steer said road roller; and drive means carried by said support means and connected to at least one of said rollers for rotating the same about its axis.

2. A road roller as defined in claim 1, wherein said support means comprises an elongated rigid frame carrying said rollers spaced from each other.

3. A road roller as defined in claim 2, wherein said mounting means of said other bearing means comprise guide means formed in said rigid frame and a slide member guided in said guide means and carrying said other bearing means of said one roller.

4. A road roller as defined in claim 3, and including unbalance means carried by said frame for vibrating said road roller, and biasing means cooperating with said slide member and biasing the same in engagement with said guide means with a force greater than the vibrating force imparted by said unbalance means on said slide member.

5. A road roller as defined in claim 4, wherein said slide member has a pair of opposite substantially horizontal faces and said guide means has a pair of guide portions respectively cooperating with said faces, and wherein said biasing means includes a wedge shaped plate sandwiched between one of said faces of said guide member and the respective one of said guide portions and urging the other of said faces in tight engagement with the other of said guide portions.

5

6. A road roller as defined in claim 5, wherein said wedge shaped plate is mounted on said one guide portion adjustable in longitudinal direction.

7. A road roller as defined in claim 3, wherein said operating means comprises fluid operated cylinder and piston means pivotally connected at opposite ends thereof to said frame and said slide member, respectively. 5

8. A road roller as defined in claim 3, wherein said drive means comprises a gear fixedly mounted on that end portion of the shaft means of said one roller which is mounted in said other bearing means, a drive pinion meshing with said gear, and housing means turnably mounting said drive pinion and connected to said slide member. 10

9. A road roller as defined in claim 8, wherein said drive means include further motor means carried by said 15

6

frame and transmission means transmitting a drive from said motor to said drive pinion.

References Cited

UNITED STATES PATENTS

505,944	10/1893	Hapgood	94—50
1,211,811	1/1917	Bailey	94—50 X
1,304,741	5/1919	Cartwright	94—50
1,650,746	11/1927	Stubbs	94—50
2,132,107	10/1938	Hamm	94—50
2,691,927	10/1954	Denton	94—50
3,048,089	8/1962	Kaltenegger	94—50
3,339,468	9/1967	Hall	94—50

NILE C. BYERS, JR., *Primary Examiner.*