

Sept. 5, 1933.

E. C. POTTER  
DISPLAY STAND

1,925,673

Filed June 30, 1930

4 Sheets-Sheet 1

Fig. 1.

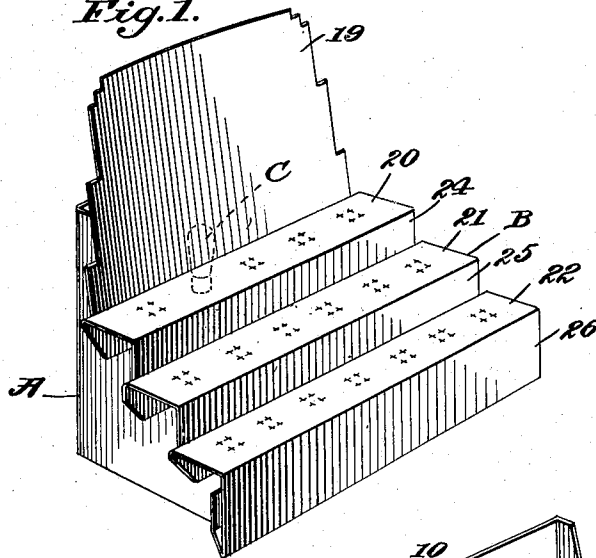

Fig. 2.

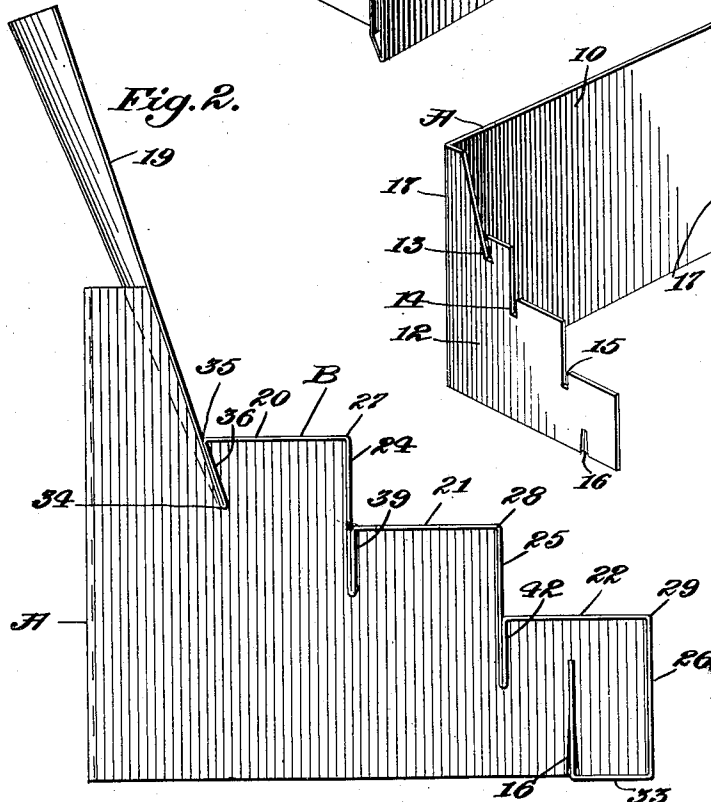
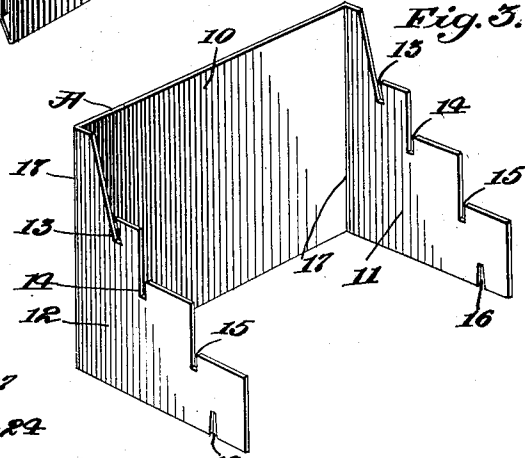

Fig. 3.



Inventor:  
Earl C. Potter  
By *H. D. [Signature]*  
Att'y.

Sept. 5, 1933.

E. C. POTTER

1,925,673

DISPLAY STAND

Filed June 30, 1930

4 Sheets-Sheet 2

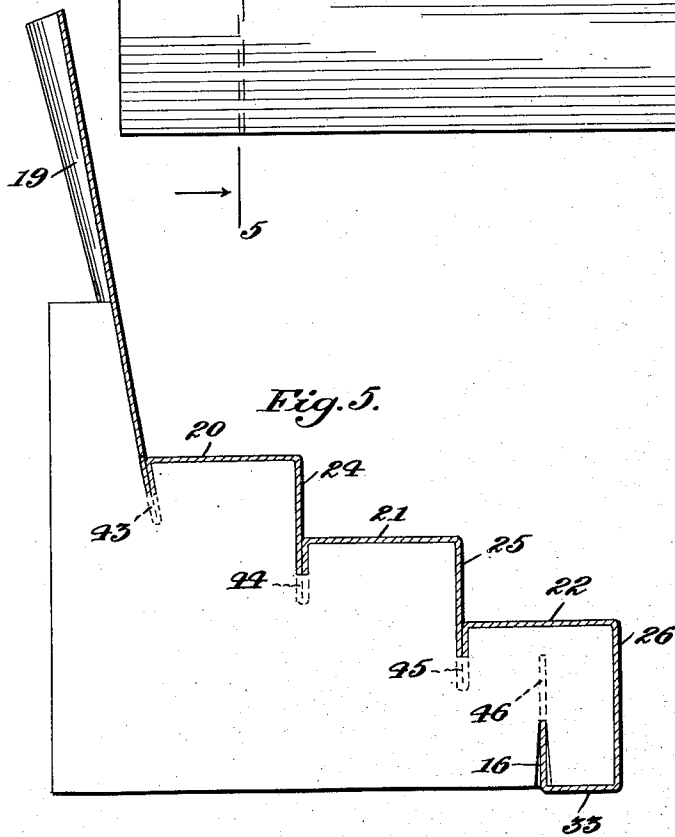
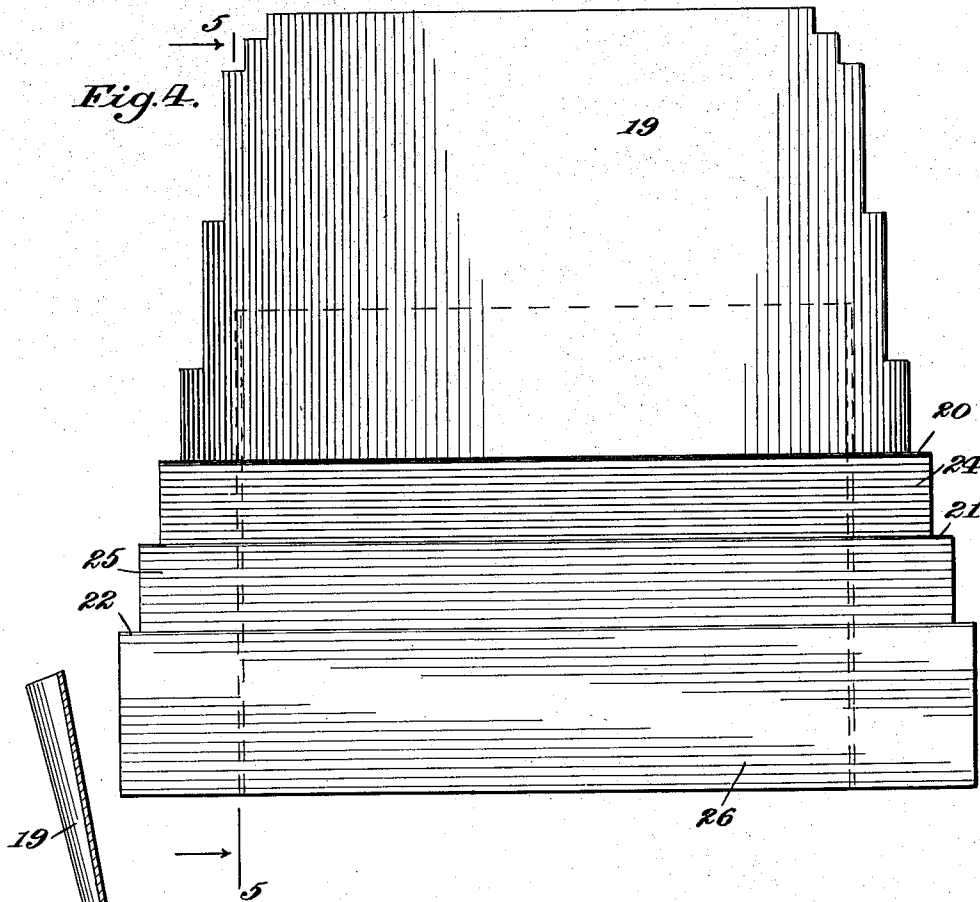

Inventor:  
Earl C. Potter  
By *[Signature]*  
Att'y.

Sept. 5, 1933.

E. C. POTTER

1,925,673

DISPLAY STAND

Filed June 30, 1930

4 Sheets-Sheet 3

Fig. 6.

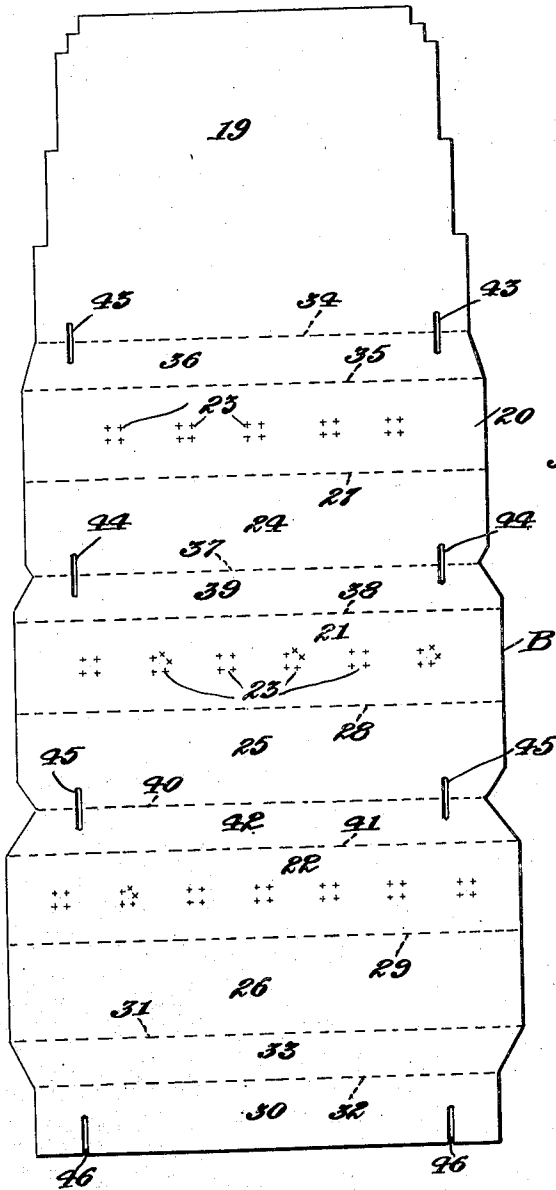
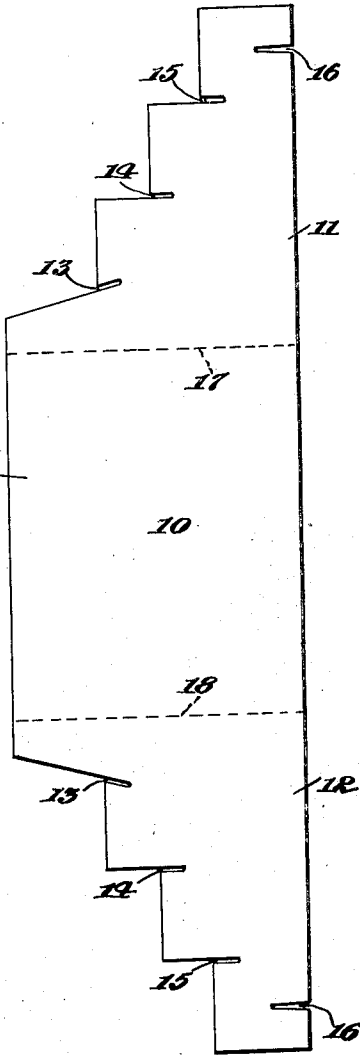

Fig. 7.



Inventor:  
Earl C. Potter  
By *H. D. D. D.*  
Atty.



# UNITED STATES PATENT OFFICE

1,925,673

## DISPLAY STAND

Earl C. Potter, Chicago, Ill., assignor to Container Corporation of America, Chicago, Ill., a corporation of Delaware

Application June 30, 1930. Serial No. 464,773

2 Claims. (Cl. 211—156)

The invention relates to improvements in display stands and more particularly to terraced stands intended primarily for the counter display of radio tubes and the like.

The principal object of the invention is to provide a display stand of the above type which may be cheaply manufactured, preferably by simple stamping operations, which may be shipped flat, and which may be readily assembled at the place of use.

A further object of the invention is to provide a stand which will support a number of articles arranged in terraced rows, one row above another, in such a way that all the articles are visible and readily available.

According to the preferred embodiment of the invention, the stand is formed from two separate blanks, one of which is folded into a supporting member, while the other member is folded into the form of steps or a terrace, which is held in place upon the support preferably by means of interengaging slots formed upon the supporting member and terraced member respectively. Both the supporting and terrace members may be formed of heavy paper, or other suitable material, the supporting member being desirably formed of faced corrugated paper board, and the terrace member of lighter material such as box board or the like. The blanks forming both members are preferably scored in one direction only by means of parallel score lines, thus permitting ready folding to allow the blanks to be shipped flat and to occupy a minimum of space. Slots are formed in the blanks, which slots are interengaged in assembling the two members.

The invention will be more readily understood by reference to the accompanying drawings and the following detailed description, which are intended to illustrate the inventive thought involved without limiting the invention to the specific details therein set forth.

In the drawings:

Fig. 1 is a perspective view of the terraced display stand, showing the terraced or stepped member assembled upon the support;

Fig. 2 is a side view of the assembled stand;

Fig. 3 is a perspective view of the supporting member set up ready to receive the stepped member;

Fig. 4 is a front view of the assembled stand;

Fig. 5 is a vertical sectional view on line 5—5 of Fig. 4;

Fig. 6 is a plan view of the blank from which the terrace or stepped member is formed;

Fig. 7 is a similar view of the blank from which the supporting member is formed; and

Figs. 8 and 9 are diagrammatic perspective views intended to illustrate the manner of assembling the terraced or stepped member upon the support.

The display stand is preferably constructed from two blanks, the blank A, Figs. 1, 3 and 7, being folded to constitute a suitable stepped support and the blank B, Figs. 1, 2, 4, 5 and 6, being folded to form a terrace upon which radio tubes or like articles C are adapted to be supported for display purposes.

Referring particularly to Figs. 6 and 7, the blanks A and B are shown in detail. The blank A, from which the support is to be formed by folding as indicated in Fig. 3, comprises a central member 10 having side wings 11 and 12 separated from the central member by means of parallel score lines 17 and 18.

A plurality of pairs of slots are formed in the wing members 11 and 12, the purpose of said slots being to cooperate with corresponding slots in the terrace member B, as will be more fully described hereinafter. The upper pair of slots 13—13 are set at an angle, while the slots 14—14, 15—15 and 16—16 are substantially vertical and parallel. The last mentioned slots, 16—16, extend upwardly from the lower edge of the blank and are intended to receive a folded-under portion of the terrace member when the parts are assembled.

The blank B is shown in detail in Fig. 6, and from this blank the terrace member is formed. As shown, the blank includes an upper panel 19, upon which may be printed suitable advertising matter relative to the goods to be displayed. This panel, when the parts are assembled, faces forwardly and is inclined at a slight angle from the vertical, as indicated in Figs. 1, 2 and 5. The blank B also includes a plurality of sections 20, 21 and 22, which, when the parts are assembled, constitute the horizontal supporting surfaces for the radio tubes or other articles to be displayed. See particularly Figs. 1, 2 and 5. These supporting surfaces are preferably provided with suitable slits 23, herein shown as in the form of a cross, designed to receive the prongs of the radio tubes.

The blank B is also provided with sections 24, 25 and 26 which, when the two blanks are assembled, form the vertical portions of the steps or terrace. These steps may be provided with suitable advertising matter, particularly the lowermost section 26, which, as indicated in

Figs. 2 and 5, contains the largest exposed surface when the stand is finally assembled.

The vertical and horizontal step surfaces are separated by means of suitable parallel score lines 27, 28 and 29, such score lines being on the under surface of the blank, to facilitate folding of the terrace. The blank B also comprises a portion 30, shown in Fig. 6 at the extreme bottom of the blank, this portion being designed to be folded up and back of the portion 26 when the parts are assembled, as clearly indicated in Figs. 1, 2, 5, 8 and 9. To permit the member 30 to be folded in this manner, score lines 31 and 32 are provided between which lies a section 33 which, in the assembled device, lies beneath the supporting member. See Figs. 2, 5, 8 and 9.

Between the upper panel 19 and the uppermost horizontal surface 20 is a pair of score lines 34 and 35, the line 34 being on the upper surface and the line 35 on the lower surface to permit folding of the blanks along these lines in opposite directions, as indicated for example in Figs. 2 and 5. The portion 36 intermediate the lines 34 and 35 will be folded up against the lower portion of the panel 19, and this double thickness of material extends downwardly by reason of the slots 13—13 in the supporting member which cooperate with a pair of slots 43—43 in the blank B.

A similar arrangement of score lines is provided between the vertical member 24 and the horizontal member 21, these portions being separated by score lines 37 and 38 of the intermediate portion 39, which, when the parts are assembled, is adapted to be folded upwardly against the lower portion of the vertical member 24, as clearly indicated in Figs. 2 and 5. Similarly, between the vertical step portion 25 and the horizontal surface 22, are score lines 40 and 41 with an intermediate portion 42. The portion 42 will be folded upwardly against the lower part of the vertical step 25.

The slots 43 have already been referred to. It will be noted that these slots are parallel and arranged adjacent opposite sides of the blank B, and these slots cross the score line 34 at right angles. Similar pairs of slots are provided at 44—44, 45—45, crossing the score lines 37 and 40 respectively. At the bottom of the blank, extending upwardly into section 30, are slots 46—46. The slots 43—43, 44—44, 45—45 and 46—46 are adapted to coact with slots 13—13, 14—14, 15—15 and 16—16 respectively in the blank A during the assembling of the device. The blanks A and B may be formed cheaply by simple stamping operations. Any desired material may be employed, but preferably faced corrugated paper board is employed for the blank A and a somewhat thinner cardboard is employed for the blank B from which the terrace member is constructed. It will be noted that the score lines 17 and 18 on the blank A are parallel, there being no cross score lines. This arrangement facilitates folding of the blank for shipment and makes assembling of the stand a very simple operation. Similarly, all the score lines on the blank B run in a single direction and are parallel with each other. This likewise makes for simplicity of construction and assembly.

To assemble the device the blank A is folded first, and set up as indicated in Fig. 3 to form the support. The section 30 of the blank B is then inserted in the slots 16 of the under side

of the wing members 11 and 12 of the blank B, the slots 46 of section 30 coacting with the slots 16, as clearly indicated in Fig. 8 of the drawings. The terrace member is then folded and the slots 45—45, 44—44 and 43—43 are successively inserted in the slots 15—15, 14—14 and 13—13 of the supporting member B, as indicated in Fig. 9. The completed stand is illustrated in perspective in Fig. 1, and in Figs. 2 and 5 the double folded arrangement of the portions which extend below the horizontal step surfaces 20, 21 and 22 are most clearly illustrated. As referred to in connection with the previous description of the blank, it will be noted that the section 26 is doubled over against the lower portion of panel 19, the section 39 is doubled against the lower part of vertical step 24 and the section 42 is doubled against the lower section of vertical member 25. The slots 43—43, 44—44 and 45—45 are formed in the lower sections of these doubled portions, this being most clearly illustrated in dotted lines in Fig. 5.

In forming the member B of readily foldable box board or similar fibrous sheet material there will be a tendency for the blank to normally assume the flat form indicated in Figs. 6 and 8; and, while the blank is readily bendable along the score lines impressed therein the material has sufficient resiliency to cause the downwardly projecting portions 36, 39 and 42 to fit snugly within the slots of the support member A, due to the tendency of the folded portions to swing away from each other at their hinged connection as shown in Fig. 9. It will thus be apparent that a neat and substantial assembly is provided in which there is no danger of the members A and B coming apart.

On the other hand, the blanks may be assembled with great ease, and may be equally as readily separated. One of the features of the invention which makes for this simplicity is the fact that no folding is required excepting in one direction. Thus there is never any question as to which fold is to be made first, the assembling of the stand being almost automatic.

Referring to Figs. 1 and 4 showing the assembled device, it will be noted that all parts of the stand are readily visible, and that the tubes on display are easily available at all times. The panel 19 is curved slightly as indicated in Figs. 1 and 2, and in practice is suitably colored. This coloring, combined with the slight curvature, gives an effect of depth which is very pleasing. Referring to Fig. 4, it will be noted that a stepped or terraced effect is provided from the direct front as well as from the side view, this being due to the configuration of the panel 19 and the progressively increasing lengths of the steps from top to bottom.

The invention has been described in great detail for the purpose of illustration, but it will be understood that the invention is not to be limited to such details.

What is claimed is:

1. A terraced display stand comprising a supporting member and a terrace member each formed from a separate blank of foldable fibre board, the supporting member comprising a back portion with stepped side wings folded at substantially right angles thereto, slots in said wings between the steps, said terrace member cooperating with the supporting member to form the stand and being formed by folding its blank along transverse parallel lines to form a plurality of steps, and means associated with

5 said terrace member cooperating with the slots  
 to maintain the terrace member in position on  
 the supporting member, said means comprising  
 integral hinged folded portions of double thick-  
 10 ness extending downward between adjacent  
 steps and entirely across the terrace member,  
 said folded portions being unsecured to each  
 other except at their hinged connection, the  
 resiliency of the fibre board of said folded por-  
 15 tions causing them to tend to swing away from  
 each other and frictionally engage the slots in  
 the supporting member whereby the terrace  
 member will be securely held in place without  
 the use of glue or similar securing means.

20 2. A terraced display stand comprising a sup-  
 porting member and a terrace member formed  
 from foldable fibre board, said supporting mem-  
 ber provided with stepped side wings, slots in  
 said wings between the steps, said terrace mem-

ber positioned upon the supporting member and  
 cooperating therewith to form the stand, said  
 terrace member being folded to form a plurality  
 of steps, and means associated with said terrace  
 member cooperating with the slots to maintain  
 80 the terrace member in position on the support-  
 ing member, said means comprising hinged  
 folded portions of double thickness integral with  
 said terrace member and extending downward  
 85 between said steps and entirely across the ter-  
 race member, said folded portions being unse-  
 cured to each other except at their hinged con-  
 nection, the resiliency of the fibre board at the  
 hinge of said folded portions causing them to  
 90 tend to swing away from each other whereby  
 they frictionally engage the inner faces of the  
 slots in said supporting member and securely  
 hold the terrace member from displacement.

EARL C. POTTER.

25  
 30  
 35  
 40  
 45  
 50  
 55  
 60  
 65  
 70  
 75

80  
 85  
 90  
 95  
 100  
 105  
 110  
 115  
 120  
 125  
 130  
 135  
 140  
 145  
 150