

R. D. PRICE.  
AUTOMATIC GUARD FOR BOTTLING MACHINES.

APPLICATION FILED NOV. 27, 1903.

2 SHEETS—SHEET 1.

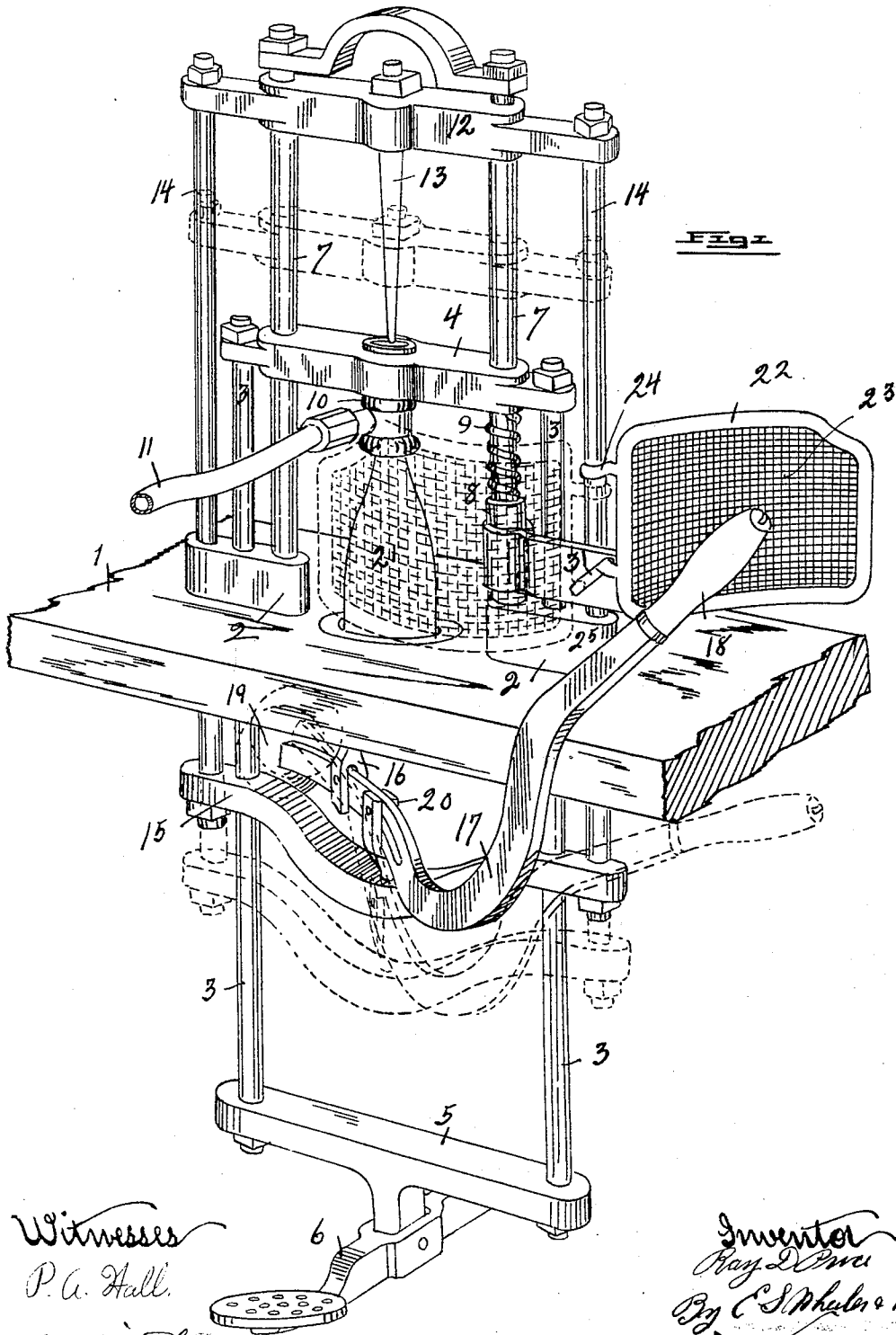

Witnesses  
 P. A. Hall.  
 C. G. Wright

Inventor  
 R. D. Price  
 By C. S. Wheeler & Co.  
 Attorneys.

R. D. PRICE.  
AUTOMATIC GUARD FOR BOTTLING MACHINES.

APPLICATION FILED NOV. 27, 1903.

2 SHEETS—SHEET 2.

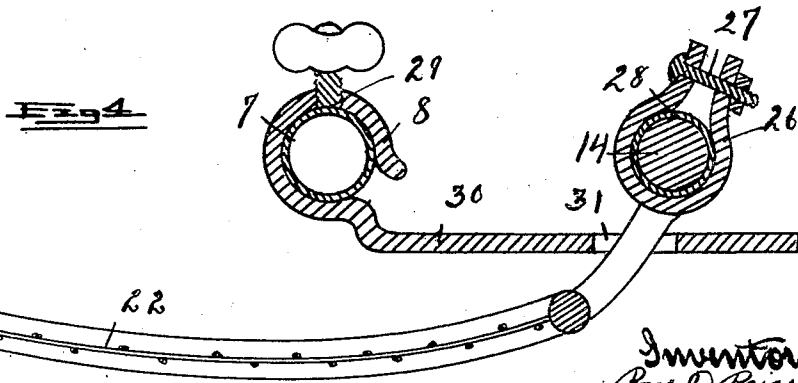
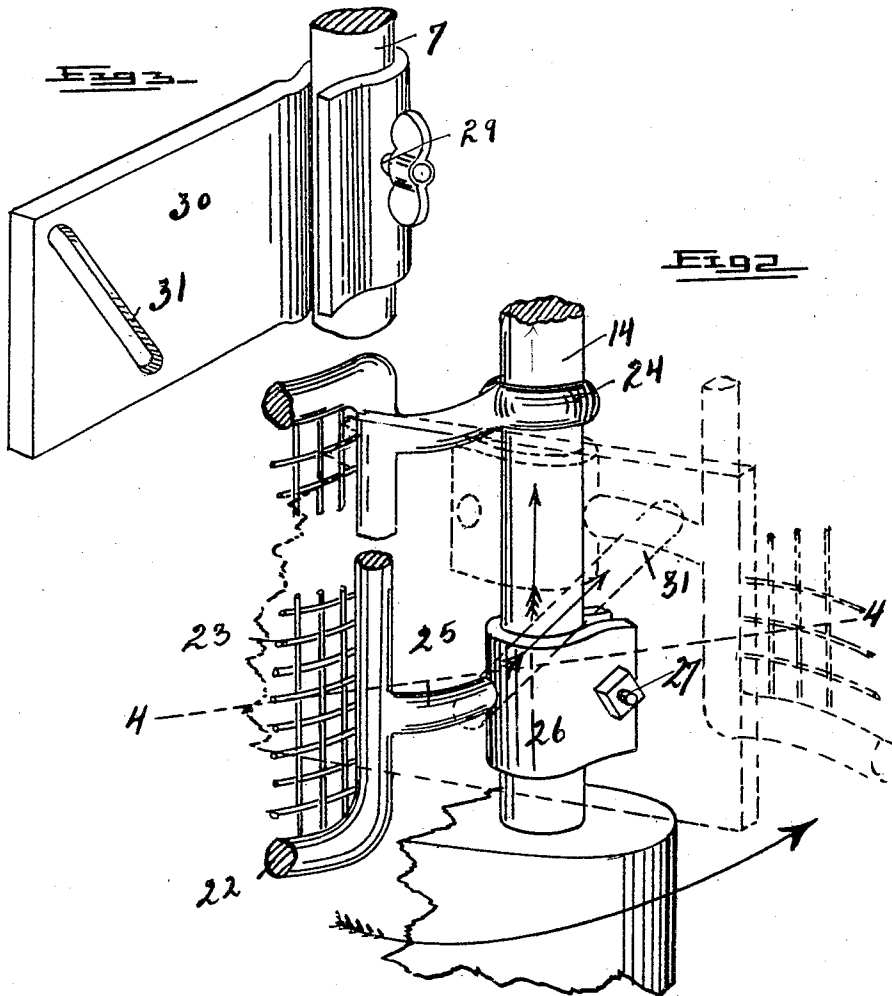

Witnesses  
 P. A. Hall.  
 C. C. Wright

Inventor  
 R. D. Price  
 By C. S. Phelps & Co.  
 Attorneys

# UNITED STATES PATENT OFFICE.

RAY D. PRICE, OF DETROIT, MICHIGAN.

## AUTOMATIC GUARD FOR BOTTLING-MACHINES.

SPECIFICATION forming part of Letters Patent No. 778,606, dated December 27, 1904.

Application filed November 27, 1903. Serial No. 182,765.

*To all whom it may concern:*

Be it known that I, RAY D. PRICE, a citizen of the United States, residing at Detroit, in the county of Wayne and State of Michigan, have invented certain new and useful Improvements in Automatic Guards for Bottling-Machines; and I do declare the following to be a full, clear, and exact description of the invention, such as will enable others skilled in the art to which it appertains to make and use the same, reference being had to the accompanying drawings, and to the figures of reference marked thereon, which form a part of this specification.

This invention relates to an automatic guard for bottling-machines; and it consists in the construction and arrangement of parts hereinafter fully set forth, and pointed out particularly in the claims.

The object of the invention is to provide a strong and efficient guard which will protect the face of the operator from flying glass should a bottle break in the operation of filling, the arrangement being such as to automatically swing the guard into position by the operation of setting the cork and to automatically carry the guard out of the way as the parts are returned to their normal position after the operation of filling.

The above object is attained by the mechanism illustrated in the accompanying drawings, in which—

Figure 1 is a perspective view of a portion of a bottling-machine, showing the application of my improved guard thereto. Fig. 2 is a fragmentary view in perspective showing the manner of mounting the guard upon one of the vertically-movable guide-rods of the machine. Fig. 3 is a perspective view of the fixed plate in which is formed an inclined slot that imparts movement to the swinging guard. Fig. 4 is a horizontal section as on line 4 4 of Fig. 2.

Referring to the characters of reference, 1 designates a suitable table upon which the mechanism is mounted. Supported on said table are suitable guides 2, through which pass the guide-rods 3, connected at their upper ends by a cross-head 4 and at their lower ends by a cross-bar 5, carrying a treadle 6, by

means of which the guide-rods 3 are actuated to reciprocate the cross-head 4. Said cross-head is mounted to slide upon the vertical guides 7, and surrounding one of said guides below the cross-head and resting upon the sleeve 8 on said guide is a coiled spring 9, which is compressed as said cross-head descends and whose tension is exerted to raise said cross-head when the treadle 6 is released.

The cross-head 4 carries a hollow fitting 10, adapted to receive the top of the bottle with its lower end and to direct the cork into said bottle, which is introduced from the upper end. Connected with said fitting is a pipe 11, which leads to a source of fluid under pressure, usually some carbonated beverage with which the bottles are filled.

Above the cross-head 4 is a second cross-head 12, also mounted upon the guides 7 and carrying a pin 13, adapted to force the cork through the fitting 10 into the bottle. Attached to the opposite ends of the cross-head 12 are the vertically-movable rods 14, which pass downwardly through the guides 2 and are attached at their lower ends to the cross-bar 15, through which pass the vertically-movable rods 3. Depending from the under face of the table is a fork 16, in which is fulcrumed a curved lever 17, carrying at one end the operative handle 18 and at the other end a counterpoise 19. The lever 17 is connected through the fork 20 with the cross-bar 15 and is adapted to actuate said cross-bar to draw upon the rods 14 and carry downwardly the cross-head 12 for the purpose of directing the cork into the bottle.

It will be understood that in filling a bottle (indicated at 21) it is placed upon the table under cross-head 4 and said cross-head brought down, so as to cause the fitting 10 to engage over the top of the bottle, when the cork is placed in said fitting and carried downwardly such distance as to direct the fluid into the bottle, when it is caused to enter said fitting through the pipe 11. After the bottle has been filled the cross-head 12 is caused to descend still farther and drive the cork through the fitting 10 into the bottle, all of which operation is common and well understood in the use. At the time the cork is driven into the

bottle to retain the contents therein the pressure is materially increased, often causing the bottle to break and the pieces to fly with great force, resulting in serious injury to the operator. To protect the face and body of the operator from these flying pieces of glass, I have devised a swinging guard 22, which comprises a frame crossed by a wire screen 23 of suitable mesh. This frame is provided at one end with an eye 24, which loosely embraces one of the vertically-movable rods 14, and with an arm 25, rigidly attached to a clip 26, which also embraces said rod and is adapted to be clamped thereto by the bolt 27, passing through the projecting sides of said clip. Within the clip and surrounding the rod 14 is a compressible bushing 28, which allows the clip to be tightly clamped upon the rod and yet allows the rod to have vertical movement therethrough. Securely fastened at 29 to one of the fixed guides 7 is a plate 30, having an oblique slot 31 therethrough, through which passes the arm 25 of the guard-frame. As the rods 14 are reciprocated vertically to actuate the cross-head 12 the arm 25 is caused to traverse said slot from end to end and because of said movement to swing the guard-frame in the arc of the horizontal circle. As the rods 14 move upwardly the arm 25 is carried to the upper end of the slot 31, thereby swinging the guard-frame outwardly, as shown by solid lines in Fig. 1. Upon the descent of said rods the arm is carried downwardly to the lower end of said slot, thereby swinging the guard in front of the bottle, as shown by dotted lines in said figure. It will be observed that the movement of the cross-head 12 is controlled by the lever 17 and that as said lever is depressed to force the cork into the bottle said guard is caused to swing in front of the bottle, so as to protect the operator from the flying glass should the bottle break at the time the cork is driven into it. It will also be observed that as the cross-head 12 rises the guard will be swung out of the way, so as to enable a free removal of the filled bottle and the placing of another bottle in the machine. As the movement of the guide-rods 14 is usually greater than necessary to effect a proper movement of the guard, provision is made for the sliding of said rod through the clip 26, as above described, so that a further movement of the rod through the clip is made possible at the limit of the movement of the guard in either direction. It will also be observed that the operation of the guard is automatic, and by the simple operation of filling and corking the bottle and releasing the bottle from the machine said guard is swung into position to protect the operator

and carried out of the way when not required, necessitating no other movements than those necessary in filling the bottle and in no sense interfering with the operation of the machine.

Having thus fully set forth my invention, what I claim as new, and desire to secure by Letters Patent, is—

1. In a bottler, the combination with suitable means for holding and filling the bottle, of a cross-head carrying a pin for driving the cork, vertically-movable rods attached to said cross-head, a lever connected with said rods, a guard mounted to swing upon one of said movable rods and means for causing said guard to move in the arc of a horizontal circle as said rod reciprocates.

2. In a bottler, the combination with the means for holding and filling the bottle, of a vertically-reciprocatory pin for driving the cork, a vertically-movable rod adapted to actuate said pin, means connected with said rod for imparting a vertical movement thereto, a swinging guard hinged to said rod, a fixed plate having an inclined slot, through which one of the hinge members of said guard extends, whereby a vertical movement of said rod will impart a swinging movement to said guard.

3. In a bottling-machine, the combination with means for holding and filling the bottle, of a cork-driver, a vertically-movable rod for actuating said driver, a wire guard hinged to said rod, a fixed plate having an inclined slot through which a hinge member of the guard extends, and means for actuating said rod to operate the cork-driver and swing said guard into and out of position.

4. In a bottler, the combination with the means for holding and filling the bottle, of a vertically-movable cork-driver, a vertically-movable rod connected therewith for actuating it, a guard hinged to said rod, one of the hinge members comprising a clamp adapted to bind said rod but allow of a vertical movement of the rod therethrough, a fixed plate having an inclined slot and an arm forming a part of the hinge member engaging in said slot.

5. In a bottler, the combination with the cork-driver, of a movable rod for actuating said driver, a guard hinged to and mounted on said rod, a fixed plate having an inclined slot, a projection on the guard engaging in said slot and means for actuating said rod.

In testimony whereof I sign this specification in the presence of two witnesses.

RAY D. PRICE.

Witnesses:

WILLIAM SIGGINS,  
ORRIN J. PRICE.