

ABSTRACT

5 A form for constructing a concrete structure includes an insulating panel and
at least one device shaped to anchor the concrete to the insulating panel. The device
includes a base embedded in the insulating panel and a rebar support extending from
the base. The rebar support is dimensioned to support rebar above a top surface of the
insulating panel when the panel is disposed horizontally and while concrete is being
poured thereon.

**DEVICE FOR ANCHORING CONCRETE TO AN INSULATING PANEL
AND FORM EMPLOYING THE DEVICE**

Field of the Invention

[0001] The present invention relates to forms for concrete walls and floors, and more particularly to a device for anchoring concrete to an insulating panel during a wall or floor forming process, and a form employing the device.

5 **Background of the Invention**

[0002] Conventional formwork for forming walls from pourable building material such as concrete consist of two opposed, typically plywood walls connected by a rod, trusswork or other connecting structure. More recently, it has become desirable to use insulating material such as expandable polystyrene (EPS) for the formwork, in order
10 to provide thermal and acoustic insulation to the finished wall. In certain applications, particularly those where it is desired to inhibit the effects of "thermal inertia" of a concrete wall so as to employ the ability of the concrete to retain heat for temperature stabilization, it is desirable to employ formwork with insulated paneling on only one side. The other side, typically of plywood, may or may not be removed
15 after full or at least partial curing of the concrete.

[0003] Various insulated formworks of these types, in addition to related technologies, have been considered, as shown for example in U.S. Patent No. 5,845,445 (Blackbeard), or U.S. Patent No. 6,314,694 (Cooper et al.).

[0004] U.S. Patent No. 6,526,713 to Moore, Jr. discloses an insulated concrete
20 structure for forming walls or floors from concrete. According to one method for forming walls, Moore proposes connecting two panels of a formwork using a web structure, a portion of which is preferably embedded in an insulating one of the panels. After the concrete has at least partially cured, one of the panels being now adjacent to the formed wall, may be removed or remain as part of the structure.
25 Moore also proposes another method for constructing a concrete wall or floor, including disposing an insulating panel in a horizontal configuration, and pouring fluid concrete onto the upward facing of the panel. A web member is partially disposed within the panel and extends through the upward facing surface of the panel. As the concrete cures it is anchored to the web member and thereby to the insulating
30 panel. For use as a wall, the composite structure is tilted upwards once the concrete has at least partially cured.

[0005] Although the above references disclose insulated formwork of various

configurations, improvements are desired particularly for enabling reinforcement of the concrete walls. It is therefore an object of an aspect of the present invention to provide a novel device for anchoring concrete to an insulating panel during a wall forming process.

5 **Summary of the Invention**

[0006] According to an aspect, there is provided a form for constructing a concrete structure, comprising:

an insulating panel; and

at least one device shaped to anchor the concrete to the insulating panel,

10 the device comprising:

a base embedded in the insulating panel;

a rebar support extending from the base and dimensioned to support rebar above a top surface of the insulating panel when the panel is disposed horizontally and while concrete is being poured thereon.

15 **[0007]** According to another aspect, there is provided a device for use in constructing a concrete structure, comprising:

a base for embedding within an insulating panel;

20 a rebar support extending from the base and shaped both to anchor the concrete to the insulating panel and to support rebar above a top surface of the insulating panel when the panel is disposed horizontally and while concrete is being poured thereon.

[0007a] According to another aspect, there is provided a form for constructing a concrete structure, comprising:

a molded insulating panel; and

25 a plurality of devices for anchoring the concrete against the insulating panel, each device comprising:

a base embedded within the insulating panel, the base defining a channel that is accessible from and open to a top surface of the insulating panel; and

30 a rebar support separate from and configured to engage the channel of the base, the rebar support being dimensioned to, once engaged to the channel, support rebar above the top surface of the insulating panel when the panel is disposed

- 2a -

horizontally and while concrete is being poured thereon, and to anchor the device within the concrete as the concrete sets, wherein the rebar support comprises a free end distal from the base configured to be encapsulated within the concrete as the concrete sets.

- 5 [0008] The form and device described herein provide advancements over known devices used for forming floors or tilt-up walls due at least in part to the ability to support rebar or other suitable reinforcement during the floor or wall forming process while the form is horizontally oriented.

Brief Description of the Drawings

- 10 [0009] Embodiments will now be described more fully with reference to the accompanying drawings in which:

Figure 1 is a cutaway side view of a concrete structure;

Figure 2 is a perspective view of one of the anchoring devices in the concrete structure of Figure 1;

- 15 Figure 3 is a perspective view of an alternative anchoring device;

Figure 4 is a perspective view of another alternative anchoring device;

Figure 5 is a perspective view of yet another alternative anchoring device;

- 3 -

Figure 4 is a perspective view of another alternative anchoring device;
Figure 5 is a perspective view of yet another alternative anchoring device;
Figure 6 is a cutaway side view of an alternative concrete structure with a
multi-part anchoring device; and

5 Figure 7 is a perspective view of yet another alternative anchoring device.

Detailed Description of the Embodiments

[0010] Figure 1 is a cutaway side view of concrete structure 10, comprising a plurality of insulating panels 20, a plurality of anchoring devices 30, reinforcing rebar 25, and a layer of concrete 50. The concrete structure 10 is constructed by pouring a layer of concrete onto a form that includes insulating panels 20, each of which are formed of expanded polystyrene (EPS) by molding. Each anchoring device 30 is embedded in a respective insulating panel 20 when insulating panel 20 is molded. Each anchoring device 30 is able to support a section of rebar 25 above the top surface of the panels 20 in cooperation with one or more other anchoring devices (into the page and not shown) when the panels 20 are horizontally oriented as shown, while concrete 50 is being poured. After pouring, once the concrete 50 has at least partially set, should it be desired to use the concrete structure 10 as a wall, concrete structure 10 is tilted upward so as to be vertically oriented. Alternatively, the concrete structure 10 may remain horizontally oriented, as shown, for use as a floor. In either case, the anchoring devices 30 serve to both anchor the concrete 50 to the insulated panels 20 and support the rebar 25 during construction of the concrete structure 10 as shown.

[0011] Figure 2 is a perspective view of one of the anchoring devices 30 in the concrete structure of Figure 1. Each anchoring device 30 is made of rigid plastic and includes a base 32. A web 34 extends from the base 32 and has a length sufficient for it to extend through the top surface 22 of the insulating panel 20. As such, web 34 has a length that corresponds with the desired thickness of the insulating panel 20 into which it is to be embedded, the desired distance the base 32 is to be from the bottom surface of the insulating panel 20, and the desired thickness of the concrete 50 so as to effectively embed the supported rebar 25 within the concrete 50. Put another way, each anchoring device 30 may be formed in various sizes and/or proportions depending upon the desired configuration of the concrete structure 10 or the desired placement of rebar 25 within the concrete structure 10. For example, in Figure 1,

some anchoring devices 30 are longer than others.

[0012] At the distal end of the web 34 is a U-shaped rebar receptacle 36 sized to receive and, to a degree, retain rebar 25. Web 34 and rebar receptacle 36 combine to form a rebar support 33 for supporting rebar 25 above the top surface 22 of the
5 insulating panel 20 when insulating panel 20 is disposed horizontally as shown in Figure 1.

[0013] The base 32 of device 30 is embedded within insulated panel 20 and has a cross-sectional dimension that serves to generally anchor the base 32 within insulated panel 20. To this end, the base 32 generally is larger in one or both transverse
10 dimensions (i.e. width and/or length) than is web 34 so as to enable to EPS when expanded to anchor the base 32 therewithin. Preferably, base 32 also provides a surface to which a fastener 80 may be attached in order to attach cladding 70 such as drywall, siding, brick veneer or the like to the bottom surface of the panel 20 into which the device 30 is to be molded.

[0014] Likewise, rebar receptacle 36 of rebar support 33 has shoulders 40 which
15 serve to anchor the device 30 to the concrete 50. In this manner, when the concrete 50 has set, device 30 serves to substantially anchor the concrete 50 to the insulated panel 20, as is advantageous for further manipulation and/or use of the concrete structure
10.

[0015] In the embodiment shown in Figure 1, each insulated panel 20 has a
20 stepped cross section such that it is a shorter height towards its edges than at its midsection. When edges of insulated panels 20 meet, together they form a channel which, when filled with concrete 50, forms a beam/column of concrete 50. The beams/columns of concrete 50 provide increased structural strength to concrete
25 structure 10. Various configurations of panels 20 may be employed to form concrete structures of various types. For example, it will be understood that in the event it is desired to form a concrete layer 50 having a uniform thickness, a form employing insulated panels 20 with a uniform thickness may be used.

[0016] Figure 3 is a perspective view of an alternative anchoring device 30a.
30 Anchoring device 30a functions in a very similar manner as does anchoring device 30

shown in Figure 2. However, its rebar receptacle 36a is a short channel formed in the top surface of web 34a, and web 34a has a uniform width along its height. A notch 35a is formed in the web 34a so as to better enable anchoring device 30a to be anchored within the concrete 50; when poured atop and around web 34a, rebar 25 and rebar receptacle 36a, the concrete 50 enters into the notch 35a and is able to set there for anchoring.

[0017] Figure 4 is a perspective view of another alternative anchoring device 30b. Anchoring device 30b functions in a very similar manner as does anchoring device 30 shown in Figure 2. However, its rebar receptacle 36b is V-shaped. The V-shaped rebar receptacle 36b has shoulders 40b which function similarly to shoulders 40 of anchoring device 30 to anchor anchoring device 30b within the concrete 50 that is poured atop and around it.

[0018] Figure 5 is a perspective view of yet another alternative anchoring device 30c. Anchoring device 30c functions in a very similar manner as does anchoring device 30 shown in Figure 2. However, its entire web 34c is V-, or wedge-shaped, and its rebar receptacle 36c is a short channel formed in the top surface of web 34c. The V-shaped web 34c functions in a similar manner to shoulders 40 of anchoring device 30 to anchor anchoring device 30c within the concrete 50 that is poured atop and around it. The rebar receptacle 36c is a short channel formed in the top surface of web 34c.

[0019] While various embodiments of the anchoring device have been shown, it will be understood that alternative configurations of anchoring device may be conceived without departing from the spirit and scope of the invention taught herein.

[0020] For example, the anchoring devices described herein may be made of molded plastic; other materials may be used such as high impact polystyrene, steel, and so forth. Depending upon the application, multiple materials may be employed, such as steel and plastic. Furthermore, for ease of manufacturability and/or transportation of the forms, the anchoring devices may be formed in multiple sections to be connected at the construction site. Figure 6 is a cutaway side view of an alternative concrete structure 10d with a multi-part anchoring device 30d. The base 32d of anchoring device 30d creates a T-shaped channel into which a web 34d with a

- 6 -

correspondingly T-shaped end may be inserted. This configuration is particularly useful for easing transportation of panels 20, because the top of the base 32d is flush with or recessed from the panel top surface and therefore panels can be stacked or otherwise handled without having to work around a protruding web 34d. The web 34
5 may be attached to the base 32d when the form is being put together onsite.

[0021] Figure 7 is a perspective view of another alternative anchoring device 30e. Anchoring device 30e is similar to the anchoring device 30 shown in Figure 2, having shoulders 40e and a generally U-shaped rebar receptacle 36e. However, anchoring device 30e has a clip for retaining a supported section of rebar 25. The clip comprises
10 two barbs 39e, each positioned on the inner face of a respective resilient side wall of the U-shaped rebar receptacle 36e. The barbs 39e are sized and spaced apart so as to, when rebar 25 is pushed into rebar receptacle 36e, be contacted by the rebar 25 and forced apart until the rebar 25 is sufficiently inserted into the rebar receptacle 36e, at which point the pressure on the barbs 39e is released and the resilient side walls
15 spring back into their generally vertical resting position. In the resting position barbs 39e are positioned partially over top of or against the rebar 25 and thereby retain rebar within the rebar receptacle 36e.

[0022] Although embodiments have been described, those of skill in the art will appreciate that variations and modifications may be made without departing from the
20 scope thereof as defined by the appended claims.

What is claimed is:

1. A form for constructing a concrete structure, comprising:
a molded insulating panel; and
a plurality of devices for anchoring the concrete against the insulating panel, each device comprising:
a base embedded within the insulating panel, the base defining a channel that is accessible from and open to a top surface of the insulating panel; and
a rebar support separate from and configured to engage the channel of the base, the rebar support being dimensioned to, once engaged to the channel, support rebar above the top surface of the insulating panel when the panel is disposed horizontally and while concrete is being poured thereon, and to anchor the device within the concrete as the concrete sets, wherein the rebar support comprises a free end distal from the base configured to be encapsulated within the concrete as the concrete sets.
2. The form of claim 1, wherein the free end comprises a portion dimensioned to receive rebar.
3. The form of claim 1, wherein each rebar support comprises a U-shaped portion dimensioned to receive rebar.
4. The form of claim 1, wherein each rebar support comprises a V-shaped portion dimensioned to receive rebar.
5. The form of claim 1, wherein each rebar support comprises a clip for retaining the rebar within the rebar support.
6. The form of claim 5, wherein each rebar support comprises a generally U-shaped portion with which the clip is associated.

- 8 -

7. The form of claim 6, wherein the clip comprises a barb on a respective one of two side walls of the generally U-shaped portion.
8. The form of any one of claims 1 to 7, wherein each device is made of plastic.
9. The form of any one of claims 1 to 7, wherein each device is made of metal.
10. The form of any one of claims 1 to 9, wherein each channel is shaped to accommodate a T-shaped end of a respective rebar support.

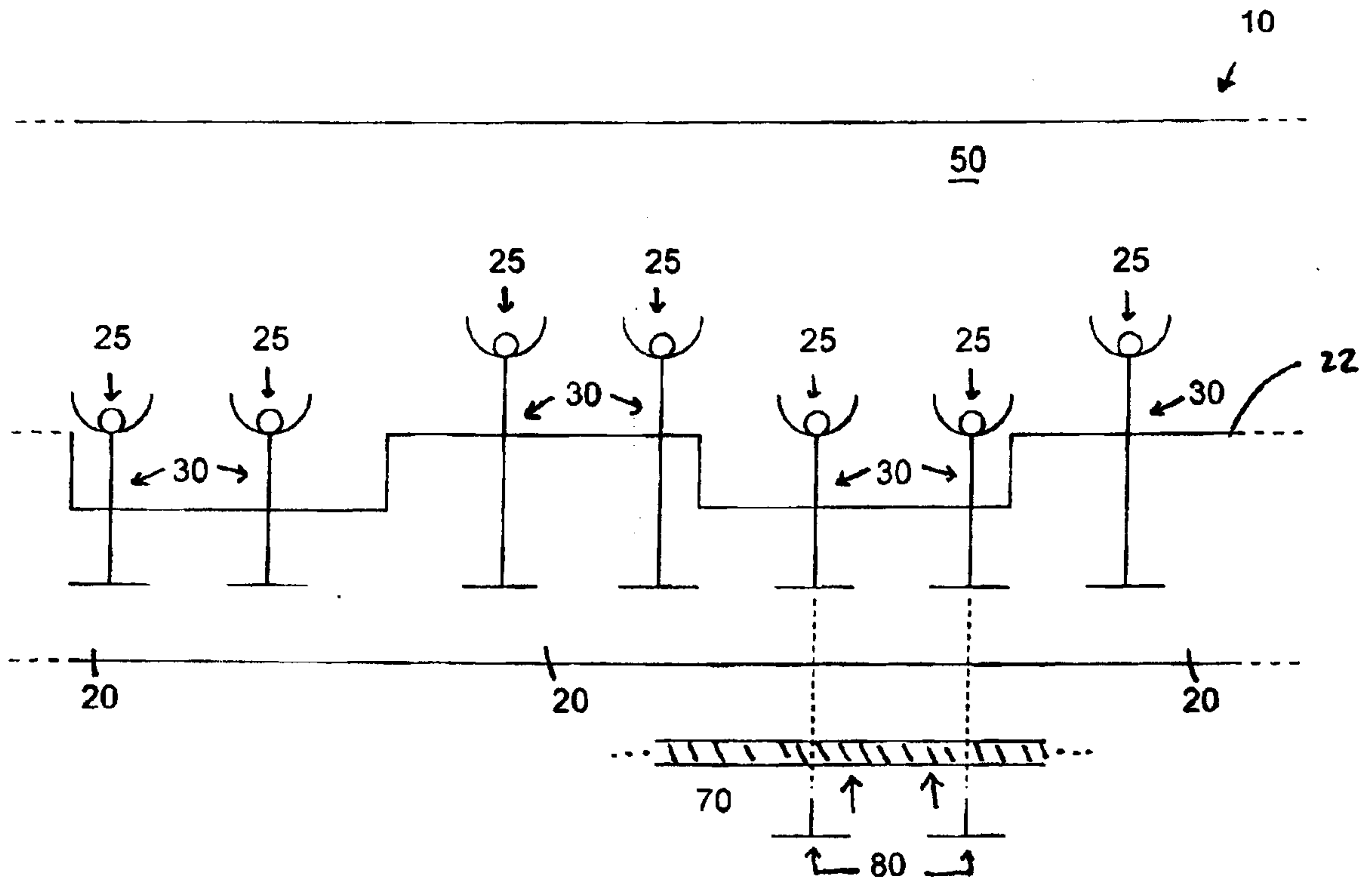

Fig. 1

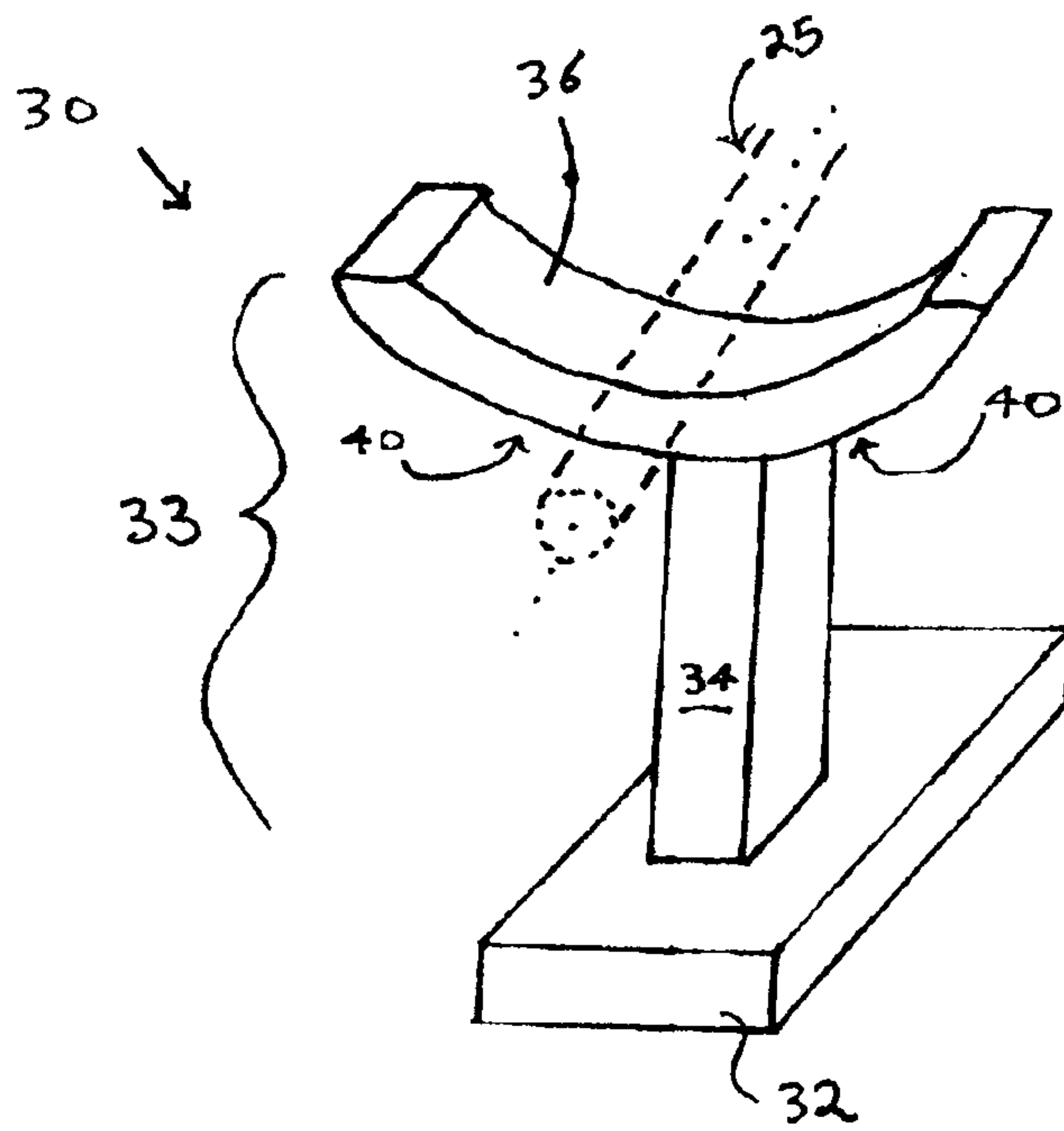

Fig. 2

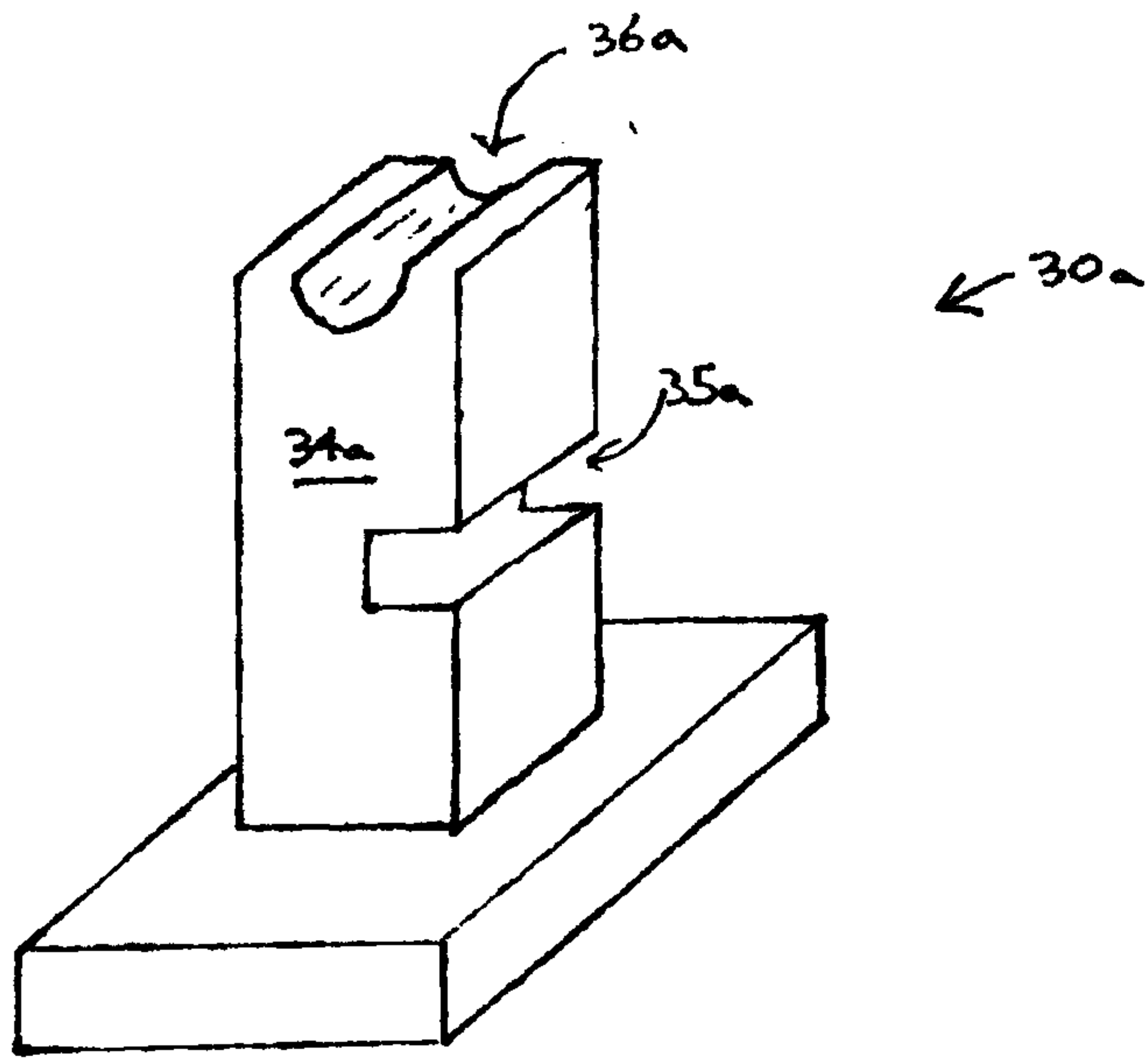

Fig. 3

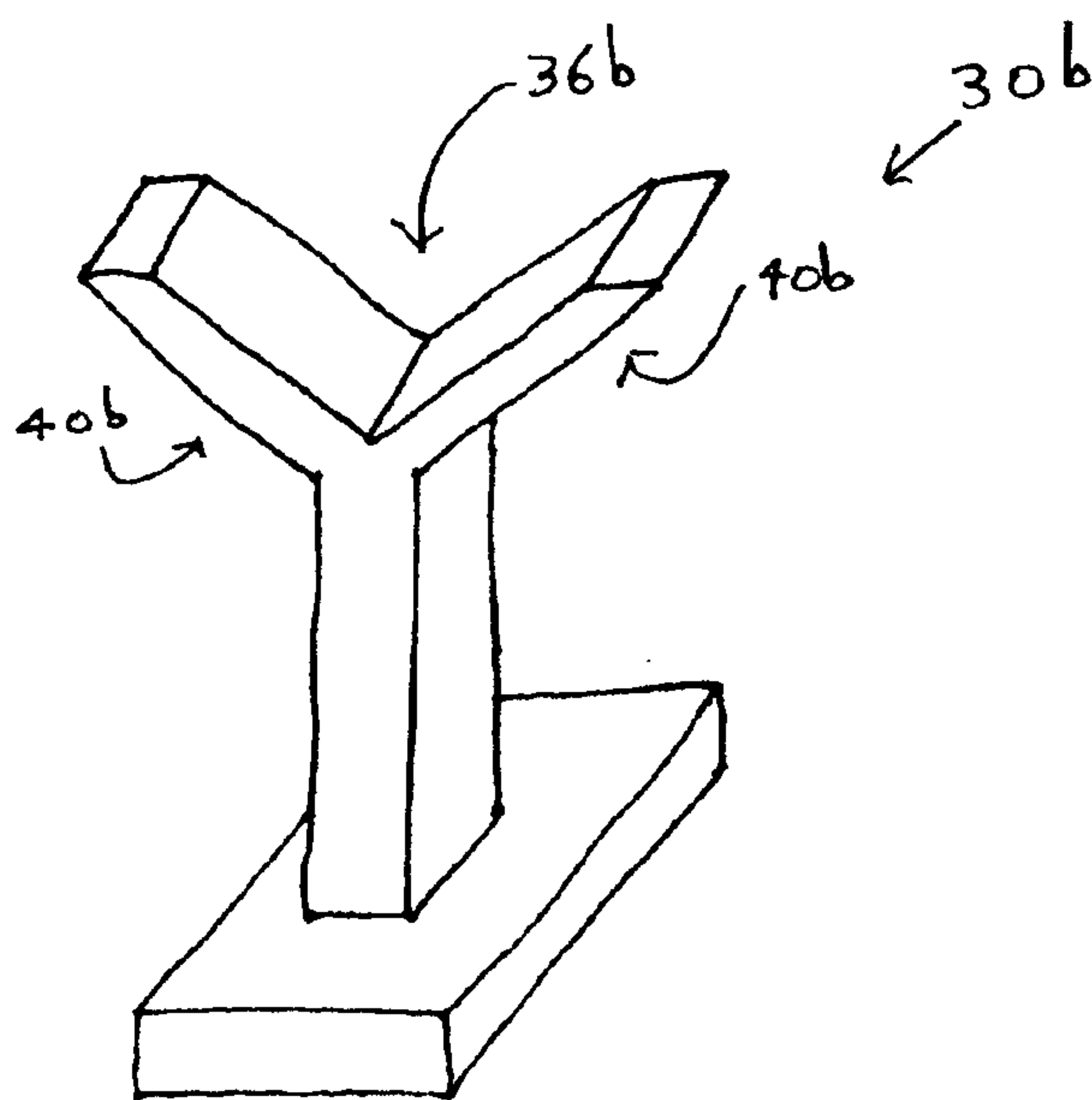

Fig. 4

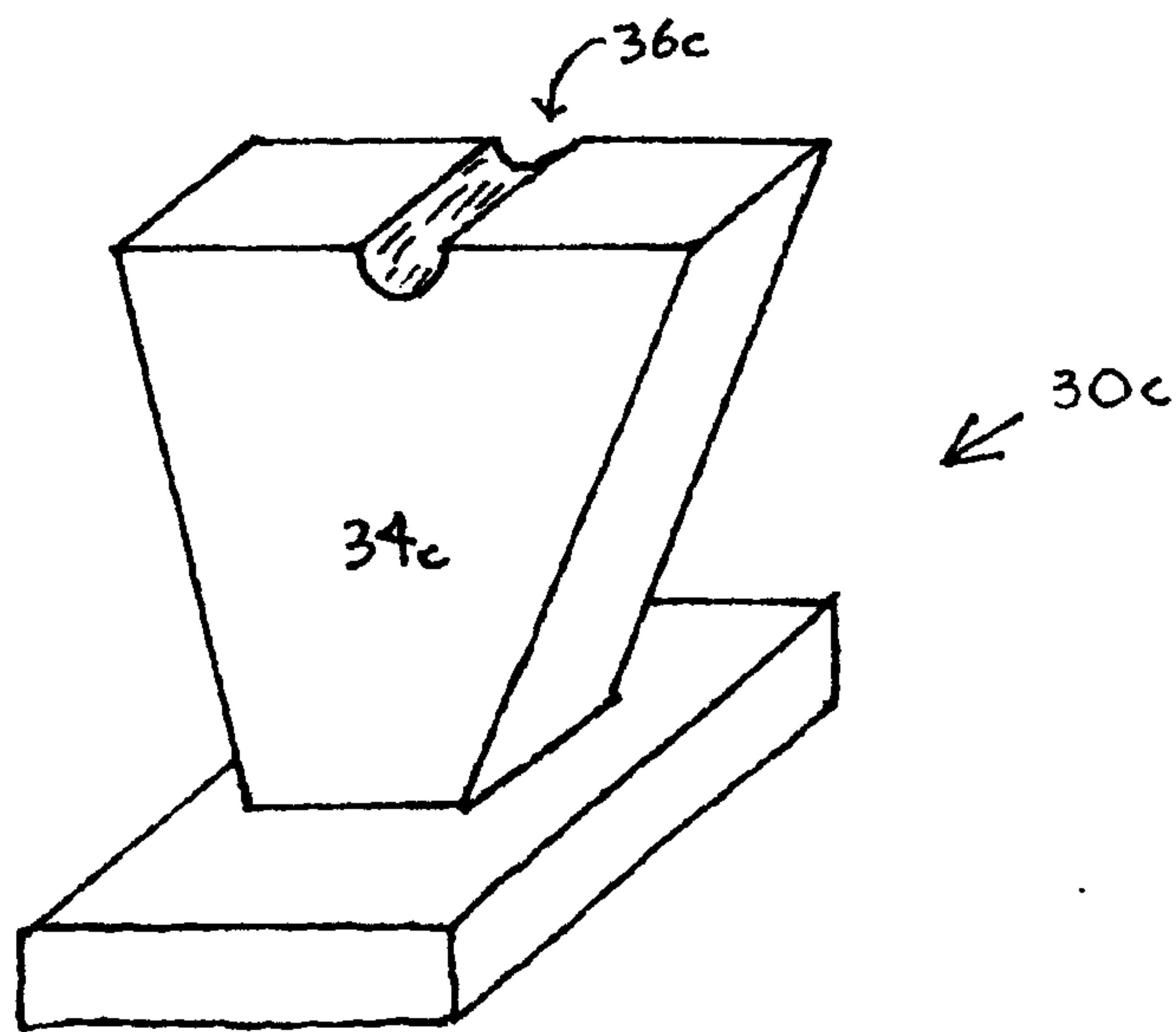

Fig. 5

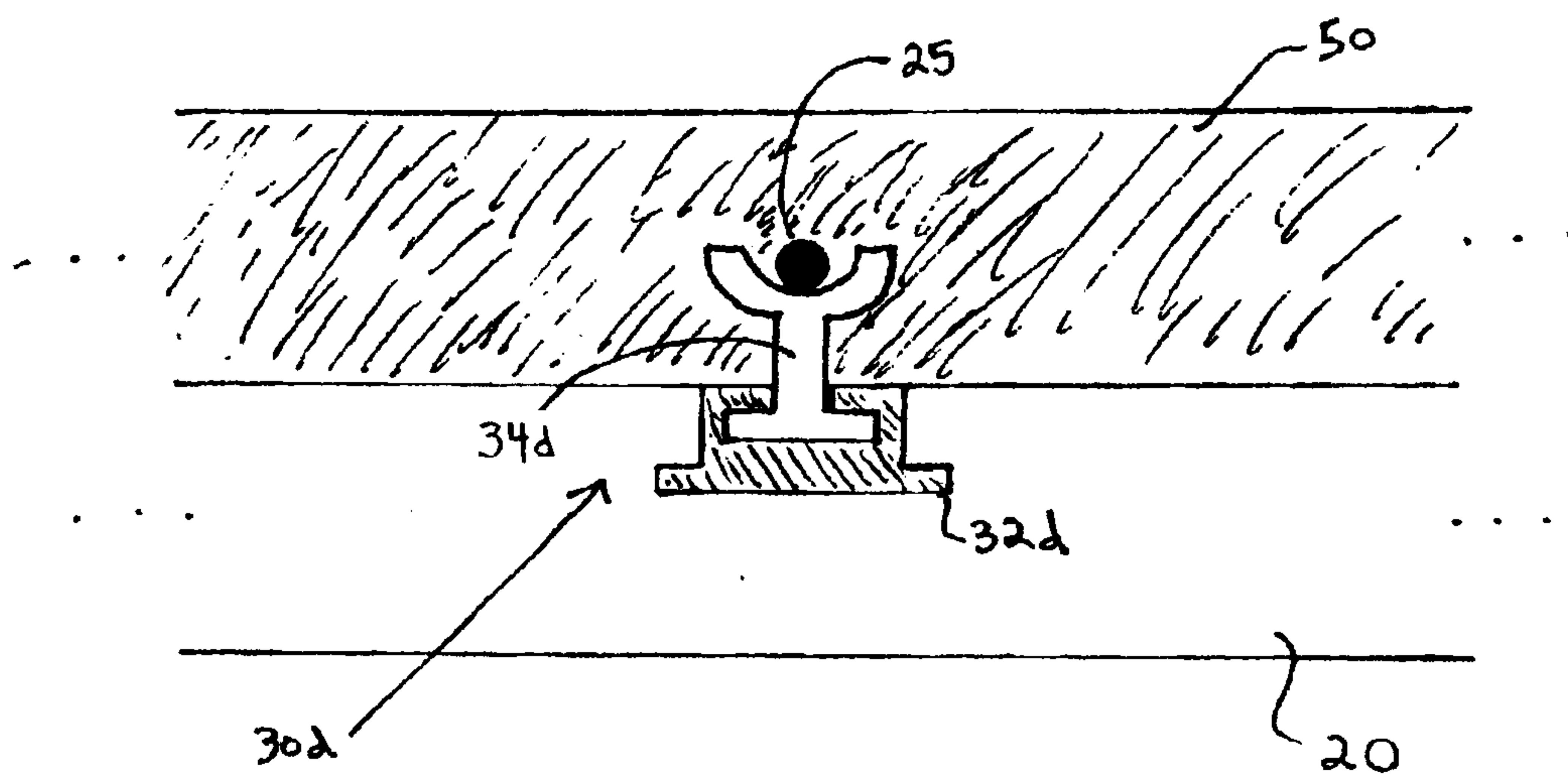

Fig. 6

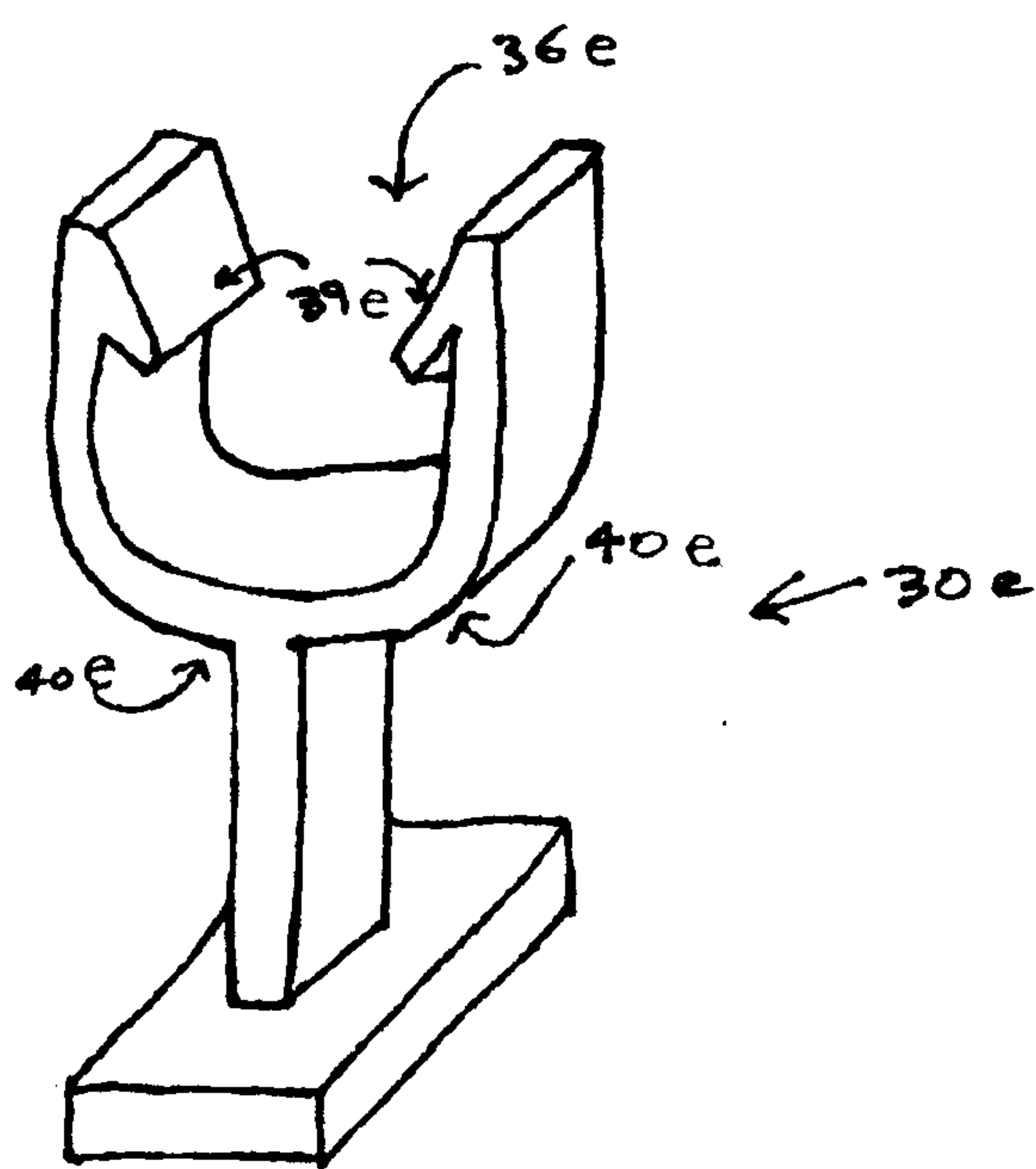

Fig. 7

