

(No Model.)

2 Sheets—Sheet 1.

W. P. PRESTON, F. J. HUDNER & J. J. KELLEY.

REVOLVING DRIER FOR DESICCATING BREWERS' GRAINS, &c.

No. 412,539.

Patented Oct. 8, 1889.

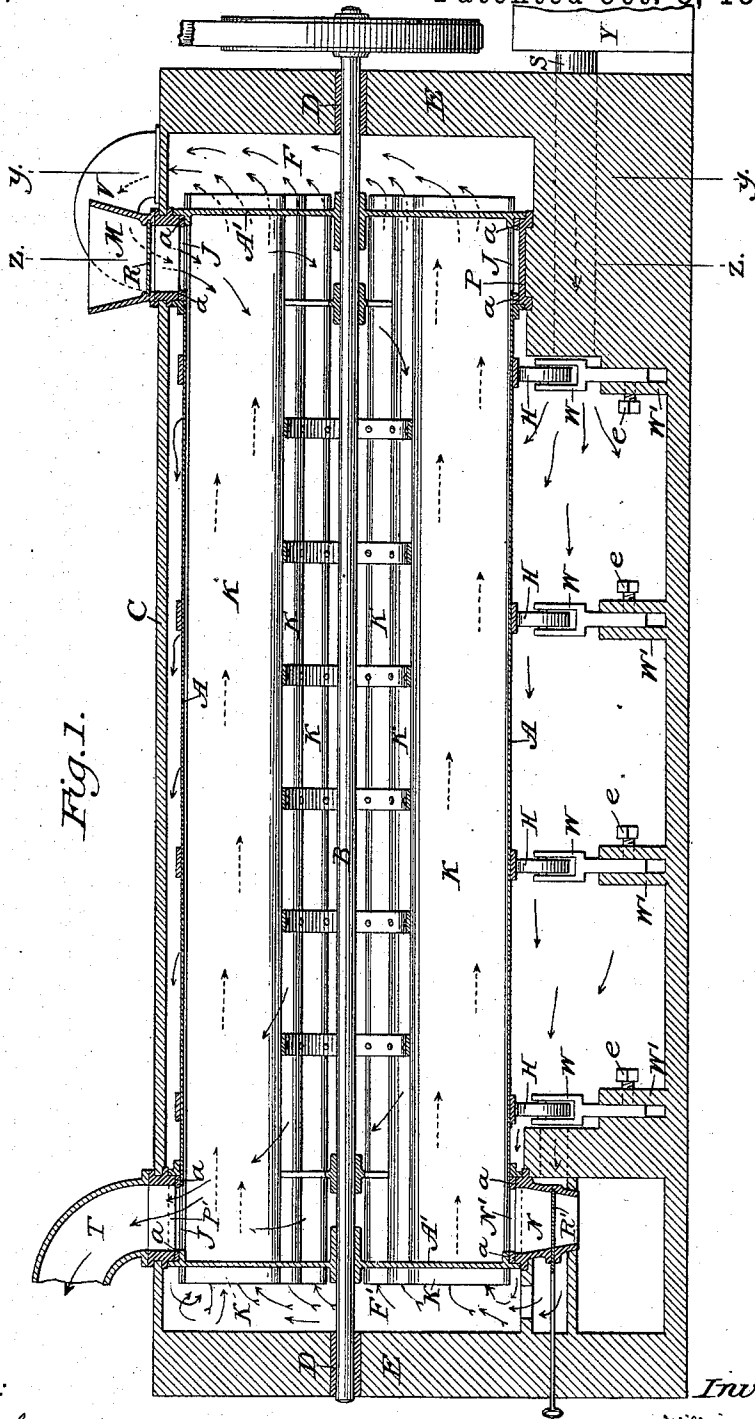

Fig. 1.

Attest:
A. N. Jespersen
E. H. Watson

Inventors:
William P. Preston
Frank J. Hudner
James J. Kelley
By *David A. Burr*
Atty.

(No Model.)

2 Sheets—Sheet 2.

W. P. PRESTON, F. J. HUDNER & J. J. KELLEY.

REVOLVING DRIER FOR DESICCATING BREWERS' GRAINS, &c.

No. 412,539.

Patented Oct. 8, 1889.

Fig. 3.

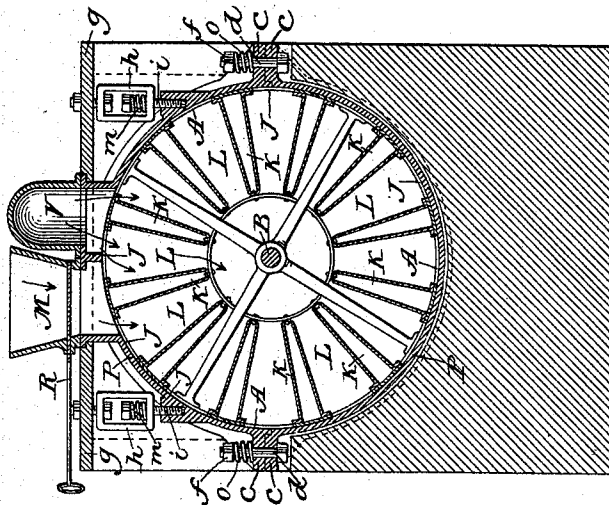
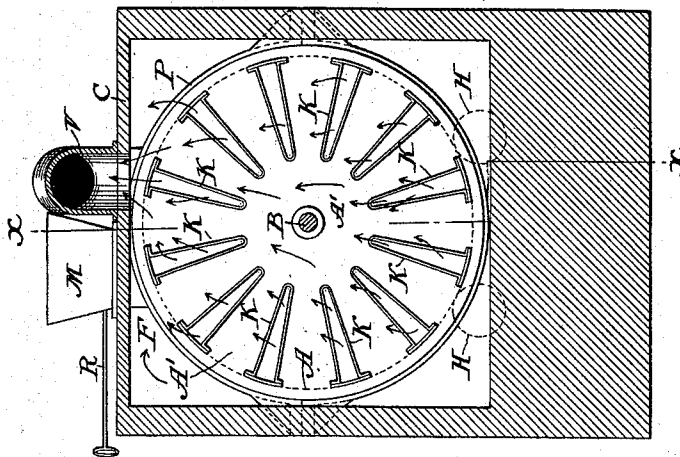

Fig. 2.



Attest:
A. K. Jesbera
E. W. Watson

Inventors:
 William P. Preston
 Frank J. Hudner
 James J. Kelley
 by *David A. Burr*
Atty.

UNITED STATES PATENT OFFICE.

WILLIAM P. PRESTON, FRANK J. HUDNER, AND JAMES J. KELLEY, OF NEW YORK, N. Y.; SAID KELLEY ASSIGNOR TO SAID PRESTON AND HUDNER.

REVOLVING DRIER FOR DESICCATING BREWERS' GRAINS, &c.

SPECIFICATION forming part of Letters Patent No. 412,539, dated October 8, 1889.

Application filed December 13, 1888. Serial No. 293,430. (No model.)

To all whom it may concern:

Be it known that we, WILLIAM P. PRESTON, FRANK J. HUDNER, and JAMES J. KELLEY, all of the city, county, and State of New York, have invented certain new and useful Improvements in Revolving Driers for Desiccating Brewers' Grains and other Materials; and we do hereby declare that the following is a full and exact description thereof, reference being had to the accompanying drawings, and to the letters of reference marked thereon, making a part of this specification.

Our invention relates to that class of grain-driers in which the material to be dried is carried through a revolving cylinder in connection with currents of hot air.

It has for its object to simplify the construction of the apparatus and increase its efficiency; and it consists of the improved arrangement and combination of the several parts thereof in manner as hereinafter described and claimed.

In the accompanying drawings, Figure 1 is a central longitudinal section of the improved apparatus in line *xx* of Fig. 2; and Figs. 2 and 3, vertical transverse sections in the lines *yy* and *zz*, respectively, of Fig. 1.

A represents a metallic cylinder closed at each end by head-plates *A' A'* and mounted to revolve upon a central rotating shaft *B*, to which it is secured. The shaft *B* is geared to a suitable motor in the customary manner and is mounted in fixed journal-bearings *DD* at each end thereof. These bearings *DD* are fitted in outer end walls *EE*, and an inclosed space or chamber *F F'* is formed between each head *A'* and the proximate end wall *E*. The cylinder is made to rest upon friction-wheels *HH* placed in pairs at proper intervals under its length, so as to relieve its journals from strain, each friction-wheel being journaled in a fork *W*, mounted adjustably in a pedestal *W'*, and secured, when adjusted vertically, by a screw-bolt *e*. By means of this vertical adjustment the friction-wheels may be kept in constant contact with the cylinder notwithstanding their wear. A series of slots or openings *J J* are formed longitudinally at regular intervals in the periphery of the cylinder *A* at each end to communi-

cate freely with the interior thereof, these openings being separated by comparatively narrow strips. Flues *KK* are extended longitudinally through the cylinder from end to end thereof to communicate freely with the end chambers *F F'*. Each flue *K* is preferably formed of a metallic plate, which is bent longitudinally, so as to be substantially U-shaped in cross-section, and which is made to extend the entire length of the cylinder and to project out with a close joint through openings in each head thereof, the two edges of the plate being fitted and secured longitudinally against the inner periphery of the cylinder and inner face of one of the strips separating the openings *J J*. The flues *K* thus severally attached to the inner periphery of the cylinder project radially inward therefrom, each a distance somewhat less than one-half the diameter of the cylinder, and serve as agitators to lift and stir up the grain admitted into the cylinder. The peripheral openings *J J* in the ends of the cylinder serve as ports for the longitudinal compartments formed therein by the flues *KK*, and which radiate from the central open space through which the axial shaft extends, and free communication is established by means of said ports between these compartments and a hopper *M* at one end of the cylinder and a discharge spout or chute *N* at the other, as hereinafter described. Each end of the cylinder *A* is inclosed by a stationary metallic band *P P'* incircling the same and made wide enough to cover fully the openings *J J* therein. These annular inclosing-bands *P P'* are divided diametrically to permit of the removal of the cylinder when required, the two divisions being united by flanges *cc* and bolts *dd*, (see Fig. 3,) and a powerful spring *o* is inserted under the nut *f* upon each bolt, so that, by reason of the elastic action thereof, the two divisions may spread apart sufficiently to prevent any undue binding of the cylinder against the bands by reason of the greater expansion of the cylinder, which may occur by reason of changes of temperature in the apparatus. The binding of the joint between the cylinder and these end bands *P P'*, because of an unequal expansion or contraction

of the cylinder or of the bands, is further-
 more guarded against by suspending the
 bands from transverse bars *g* by means of
 turn-buckles *h* and bolts *i* and interposing
 5 spiral springs *m* between the head of each
 bolt and its turn-buckle, as illustrated in Fig.
 3. If, therefore, from any cause the cylinder
 A is left to bear upon the bands P P' so as
 to create a tendency to bind therein, the
 10 bands will yield by reason of the resiliency
 of the springs *m* sufficiently to prevent undue
 friction and allow the cylinder to find and
 maintain its bearing upon the friction-wheels
 H H in manner as described. The joint be-
 15 tween the edge of each band is made close
 and accurate by means of interposed pack-
 ing-rings *a a*, secured to the cylinder in any
 suitable manner. The receiving-hopper M is
 mounted upon the upper division of the an-
 20 nular band P at the front end of the cylin-
 der, to communicate through the openings J
 J with the radial segmental compartments L
 L, while a discharge-opening N' is formed in
 the lower division of the corresponding band
 25 P' at the opposite end of the cylinder,
 whereby communication is established in
 like manner between said radial compart-
 ments L L and the discharge spout or chute
 N. The hopper M and the discharge-spout
 30 N are each controlled by a suitable valve R
 R'. The upper portion of the band P' is
 fitted with an exhaust pipe or flue T for the
 discharge of the vapor and hot air from the
 drying-compartments L L of the cylinder.
 35 The end chambers F and F' are overarched
 and made perfectly tight in connection with
 the end walls E E and suitable lateral walls.
 The cylinder A is inclosed within a casing
 C, of brick or metal, overarching the same,
 40 and the encircling chamber formed thereby
 is connected at the receiving end of the ap-
 paratus with a suitable furnace Y and at its
 opposite end with the chamber F'. The
 chamber F at the receiving end is made to
 45 communicate freely, by means of a bent con-
 necting-pipe or flue V, with an opening in
 the fixed band P, and through it with the
 peripheral ports J J of the cylinder.

In the operation of the machine the brew-
 50 ers' grains or other damp or wet material to
 be dried is fed into the machine through the
 hopper M, and dropping through the open-
 ings J J, registering therewith in the periph-
 ery of the revolving cylinder A, falls into the
 55 segmental compartments L L. As the cylin-
 der A revolves the grains will be constantly
 lifted and carried up by the radial walls of
 the longitudinal flues K K toward the top of
 the cylinder and dropped, so as to fall through
 60 the open central space into the lower com-
 partments. The grain is thus automatically
 kept in constant agitation in passing forward
 from the receiving to the discharge end of
 the cylinder, and is thereby fully exposed to
 65 the currents of the hot air therein, its for-
 ward movement being enforced by the weight
 and pressure of the grain admitted through

the hopper or by a slight inclination of the
 cylinder. Upon reaching the rear end the
 grain drops through the openings J J in said 70
 end into the discharge-spout N, and through
 it into the receptacle beneath it. In the mean-
 time, as the grain is thus carried forward in
 constant agitation through the cylinder from
 the hopper M to the discharge-spout N, a 75
 stream of dry hot air admitted directly from
 the furnace Y into the chamber encircling the
 cylinder A and carried longitudinally over
 and around the exterior of the cylinder A en-
 ters the chamber F', passes thence into and 80
 through the longitudinal flues K K, by which
 it is led into the end chamber F, and flows
 thence through the flue V into the drying-
 space formed by the compartments L L of the
 cylinder, where it is brought into direct con- 85
 tact with the agitated mass of grain therein,
 so as to reach every particle thereof, and it is
 finally discharged, with the moisture taken
 up from the grain, through the exhaust-flue T.
 The cylinder or drying-chamber is thus heated 90
 to a temperature which produces a rapid
 evaporation of moisture from the grain trav-
 eling through the longitudinal compartments
 L L thereof, and the direct contact of the hot
 air and gases with the grain so heated, and 95
 which is in constant agitation, as described,
 promotes and assists said evaporation and
 thoroughly dries the grain by rapidly taking
 up and carrying off the vapor liberated there-
 100 from. The drying of the grain is thus ef-
 fected with great economy of time, heat, and
 power.

We claim as our invention—

1. The combination, in a drying apparatus,
 of a furnace, a revolving drying-chamber 105
 formed with longitudinal compartments or re-
 cesses opening and radiating from its axial
 center, external hot-air flues placed between
 said compartments to extend the length of
 said drying-chamber and communicate medi- 110
 ately therewith at one end and with the fur-
 nace at the other, a hopper communicating
 with the end of the drying-chamber at which
 the hot air enters the same, and a discharge-
 flue and a discharge-spout communicating 115
 with the opposite end of said chamber, sub-
 stantially in the manner and for the purpose
 herein set forth.

2. The combination, in a drying apparatus,
 with a revolving drying-chamber formed with 120
 longitudinal compartments opening or radi-
 ating from its axial center, of longitudinal
 flues constituting the partitions between said
 radial compartments and which are made to
 extend outwardly beyond the same, a closed 125
 outer chamber formed at each end of the dry-
 ing-chamber and into which said longitudinal
 flues open, a furnace connected with one of
 said end chambers, a flue connecting the op-
 130 posite end chamber with the compartments of
 the revolving drying-chamber through periph-
 eral ports in the proximate end of the latter,
 a hopper communicating with the same pe-
 ripheral ports, a discharge-spout and a dis-

charge-flue both communicating with said compartments through peripheral ports therein at the opposite end of the drying-chamber, and stationary bands covering and closing the peripheral ports at each end of the drying-chamber when they are not in register with the hopper, the discharge-spout, or the discharge-flue, all substantially in the manner and for the purpose herein set forth.

10 3. The combination, in a grain-drying apparatus, of the revolving cylinder having peripheral ports in its ends, diametrically-divided apertured bands inclosing said ends and covering said ports, bolts passing through lateral
15 lugs or flanges in the divisions of the band to unite them, and spiral springs encircling the bolts to permit an automatic expansion of the divided bands, substantially in the manner and for the purpose herein set forth.

20 4. The combination, in a grain-drying appa-

ratus, of the revolving cylinder having peripheral ports in its ends, diametrically-divided apertured bands inclosing said ends and covering said ports, suspension-bolts by which said bands are upheld, and spiral springs encircling the bolts to permit of an independent play of the bands thereon, substantially in the manner and for the purpose herein set forth.

In testimony whereof we have signed our names to this specification in the presence of two subscribing witnesses.

WILLIAM P. ^{his} × PRESTON.
FRANK J. ^{mark} HUDNER.
JAMES J. KELLEY.

Witnesses:

A. N. JESBERA,
E. M. WATSON.