

(No Model.)

A. R. FERGUSSON.
BOX OR CAN.

No. 604,492.

Patented May 24, 1898.

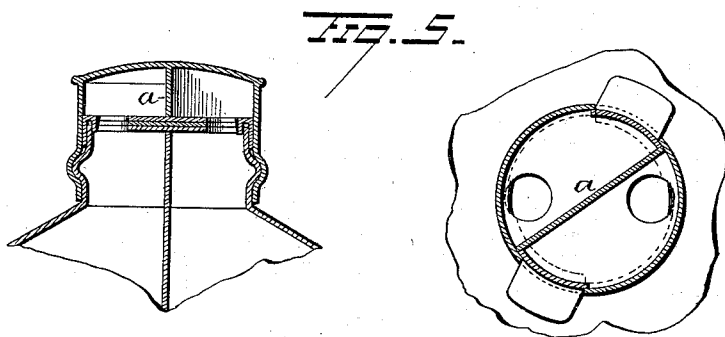
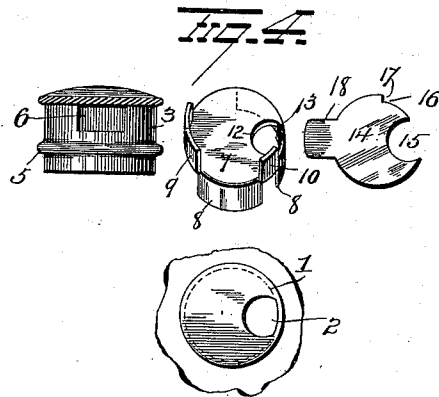
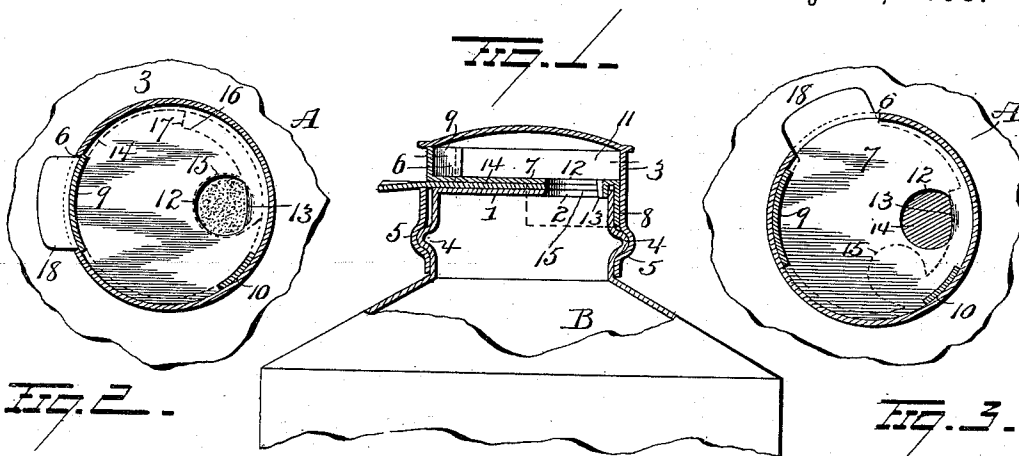

WITNESSES
E. J. Nottingham
G. F. Downing

INVENTOR
A. R. Ferguson
By H. A. Seymour
Attorney

UNITED STATES PATENT OFFICE.

ALAN ROBB FERGUSON, OF BALTIMORE, MARYLAND, ASSIGNOR TO
HENRY F. MILLER AND GEORGE MILLER, OF SAME PLACE.

BOX OR CAN.

SPECIFICATION forming part of Letters Patent No. 604,492, dated May 24, 1898.

Application filed October 9, 1897. Serial No. 654,653. (No model.)

To all whom it may concern:

Be it known that I, ALAN ROBB FERGUSON, of Baltimore, in the State of Maryland, have invented certain new and useful Improvements in Boxes or Cans; and I do hereby declare the following to be a full, clear, and exact description of the invention, such as will enable others skilled in the art to which it appertains to make and use the same.

My invention relates to an improvement in boxes or cans for containing material to be dispensed, one object of the invention being to provide simple and efficient means whereby the material can be discharged from the box or can in small and definite quantities.

A further object is to provide a box or can with efficient means whereby the material can be discharged from the same in measured quantities and so that the box or can may be normally kept tightly closed, and thus prevent the escape of aroma or flavor of the material.

A further object is to produce a receptacle having a discharging device which shall be simple in construction, cheap and easy to manufacture, and which shall be effectual in all respects in the performance of its functions.

With these objects in view the invention consists in certain novel features of construction and combinations and arrangements of parts, as hereinafter set forth, and pointed out in the claims.

In the accompanying drawings, Figure 1 is a vertical sectional view showing the features of my invention. Figs. 2 and 3 are horizontal sectional views showing the movable parts in different positions. Fig. 4 illustrates the several parts of the top dismembered, and Fig. 5 is a modification showing a partition for dividing the device into two chambers.

A represents a box or can, and B the cover thereof, said cover being provided with a neck C. The upper end of the neck C is closed by a fixed disk 1, and said disk is provided at or near its periphery with a hole 2. A cap 3 is revolubly mounted on the neck C and prevented from escape therefrom by means of beads 4 5, formed on the neck and cap, respectively. The peripheral wall of the loose cap 3 is cut away to form a slot or opening 6.

A disk 7 is loosely disposed within the cap 3 and provided with depending flanges 8, which serve to extend the bearing of the periphery of said disk against the inner wall of the cap. The disk 7 is also provided with upwardly-projecting flanges 9 10, which bear against the top of the cap, and thus serve to retain the disk a short distance from the top of the cap, whereby to form a measuring-chamber. The flange 9 also serves to close the slot or opening 6 in the peripheral wall of the cap. The disk 7 is further provided with a hole 12 and with a lug or projection 13 at the periphery of said hole, said lug or projection being adapted to depend into the hole 2 in the disk 1 at the peripheral wall of the latter, and thus prevent said disk 7 from turning. Another disk 14 is mounted in the cap 3 and provided with an opening 15, to be made to register with the openings in the disks 1 and 7, and said disk 14 is also provided with a peripheral recess 16 for the accommodation of the lug or projection 13 on the disk 7, one end of said recess forming a shoulder 17, against which said lug or projection is adapted to abut. The disk 14 is further provided with a lip 18, which projects through the peripheral opening 6 in the cap 3 and serves to prevent the rotation of said disk 14 independently of the cap and also serves as a sort of spout to guide the material from the device.

From the construction and arrangement of parts above described it will be seen that when the parts are in their normal positions the peripheral slot or opening 6 in the cap will be closed by the flange 9 of disk 7 and that the holes in the disks 1, 7, and 14 are in alignment. With the parts in these positions and the box or can inverted the material contained therein will flow through the holes in the disks and into the measuring-chamber 11. Now when the cap 3 is turned the disk 14 will be turned with it, so that the slot or opening 6 in the cap will be moved away from the flange 9 of disk 7, and thus uncover said opening. At the same time the opening in the disk 14 will be moved out of line with the holes or openings in the disks 1 and 7, and thus communication between the body of the box or can and the measuring-chamber will be closed. The contents of the measuring-cham-

ber can then be discharged, the material being properly directed onto or into the device with which it is intended for use by means of the lip 18.

5 The construction and arrangements of parts above described are well adapted for use on boxes or cans divided into two or more compartments, it being only necessary in such case to provide the disks with duplicate holes
10 and lugs and divide the cap 3 into two compartments by means of a partition *a*, Fig. 5, to correspond with the compartments in the box or can. The cap will also preferably be provided with outlets corresponding in number
15 with the number of compartments in said cap, although a single outlet common to both or all the compartments may be employed, if desired.

20 Having fully described my invention, what I claim as new, and desire to secure by Letters Patent, is—

1. The combination with a receptacle having a neck at one end, of a movable cap having an outlet-opening, a disk within said cap
25 having a flange to close said outlet-opening and arranged to form a measuring-chamber within the cap, said disk also having a hole therein, a lug projecting from said disk and

adapted to engage the neck of the receptacle, and another disk having a hole and a shoulder
30 to engage said lug, and a lip on said last-mentioned disk, said lip projecting through the outlet-opening of the cap, substantially as set forth.

2. The combination with a receptacle having a neck at one end and a fixed disk at the
35 end of said neck, said disk having a hole therein, of a movable cap having an outlet-opening, a disk within said cap and forming a measuring-chamber within the cap, a flange
40 on said disk to close the outlet-opening of the cap, a lug on said disk to enter the opening in the fixed disk, and a third disk within said cap and having a hole therein to register with
45 the holes in the other disks and a lip on said last-mentioned disk and passing through the outlet-opening of the cap, substantially as set forth.

In testimony whereof I have signed this specification in the presence of two subscribing
50 witnesses.

ALAN ROBB FERGUSON.

Witnesses:

A. J. SCOPINICH,
CHAS. S. W. BOULDIN.