

(19) World Intellectual Property Organization
International Bureau



(43) International Publication Date
26 January 2012 (26.01.2012)

PCT

(10) International Publication Number
WO 2012/012241 A2

(51) International Patent Classification:
G11C 29/00 (2006.01) *B65G 1/04* (2006.01)

(72) Inventor; and
(75) Inventor/Applicant (for US only): **TRUEBENBACH, Eric, L.** [US/US]; 5 Firecut Lane, Sudbury, MA 01776 (US).

(21) International Application Number:
PCT/US2011/043864

(74) Agents: **GERRATANA, Frank, L.** et al.; Fish & Richardson P.C., P.O. Box 1022, Minneapolis, MN 55440-1022 (US).

(22) International Filing Date:
13 July 2011 (13.07.2011)

(25) Filing Language: English

(26) Publication Language: English

(30) Priority Data:
12/840,399 21 July 2010 (21.07.2010) US

(71) Applicant (for all designated States except US): **TERADYNE, INC.** [US/US]; 600 Riverpark Drive, North Reading, MA 01864 (US).

(81) Designated States (unless otherwise indicated, for every kind of national protection available): AE, AG, AL, AM, AO, AT, AU, AZ, BA, BB, BG, BH, BR, BW, BY, BZ, CA, CH, CL, CN, CO, CR, CU, CZ, DE, DK, DM, DO, DZ, EC, EE, EG, ES, FI, GB, GD, GE, GH, GM, GT, HN, HR, HU, ID, IL, IN, IS, JP, KE, KG, KM, KN, KP, KR, KZ, LA, LC, LK, LR, LS, LT, LU, LY, MA, MD, ME, MG, MK, MN, MW, MX, MY, MZ, NA, NG, NI, NO, NZ, OM, PE, PG, PH, PL, PT, RO, RS, RU, SC, SD, SE, SG, SK, SL, SM, ST, SV, SY, TH, TJ, TM, TN, TR, TT, TZ, UA, UG, US, UZ, VC, VN, ZA, ZM, ZW.

[Continued on next page]

(54) Title: BULK TRANSFER OF STORAGE DEVICES USING MANUAL LOADING

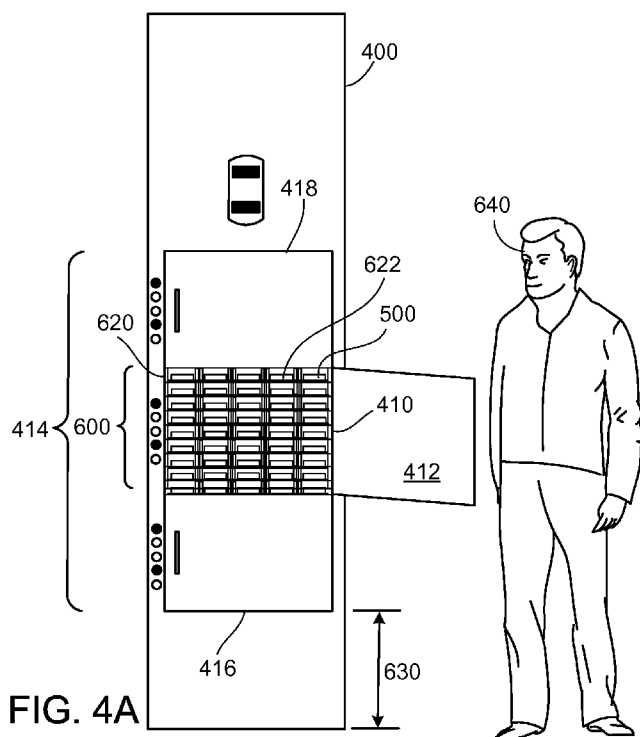

(57) Abstract: A storage device transfer station is provided for transferring storage devices from a human operator to automated machinery for testing. The storage device transfer station includes a plurality of slots each capable of holding a storage device. The plurality of slots is arranged in at least one field, and the field is arranged between two parallel planes. Each slot has a first open end and a second open end, such that each open end is accessible for loading and unloading a storage device. The first open ends are accessible at a first plane of the two parallel planes and the second open ends are accessible at a second plane of the two parallel planes.



WO 2012/012241 A2



(84) Designated States (*unless otherwise indicated, for every kind of regional protection available*): ARIPO (BW, GH, GM, KE, LR, LS, MW, MZ, NA, SD, SL, SZ, TZ, UG, ZM, ZW), Eurasian (AM, AZ, BY, KG, KZ, MD, RU, TJ, TM), European (AL, AT, BE, BG, CH, CY, CZ, DE, DK, EE, ES, FI, FR, GB, GR, HR, HU, IE, IS, IT, LT, LU, LV, MC, MK, MT, NL, NO, PL, PT, RO, RS, SE, SI, SK,

SM, TR), OAPI (BF, BJ, CF, CG, CI, CM, GA, GN, GQ, GW, ML, MR, NE, SN, TD, TG).

Published:

— *without international search report and to be republished upon receipt of that report (Rule 48.2(g))*

Bulk Transfer of Storage Devices Using Manual Loading

TECHNICAL FIELD

This disclosure relates to bulk transfer of storage devices to and from storage device testing systems and transfer stations for storage device testing systems.

5

BACKGROUND

Storage device manufacturers typically test manufactured storage devices for compliance with a collection of requirements. Test equipment and techniques exist for testing large numbers of storage devices serially or in parallel. Manufacturers tend to test large numbers of storage devices simultaneously. Storage device testing systems typically include one or more racks having multiple test slots that receive storage devices for testing.

Current storage device testing systems use an operator, a robotic arm, or a conveyer belt to individually feed storage devices to a transfer location for loading into the testing system for testing. Other current storage device testers use a tote or a mobile tote to load or unload multiple storage devices to a transfer location at the same time. A robotic arm of the testing system retrieves the storage devices individually or in small batches from the transfer location and loads them in test slots for testing.

SUMMARY

In general, this disclosure relates to the bulk transfer of storage devices using manual loading.

In one aspect, a storage device transfer station is provided for transferring storage devices from a human operator to automated machinery for testing. The storage device transfer station includes a plurality of slots each capable of holding a storage device. The plurality of slots is arranged in at least one field arranged between two parallel planes. Each slot has a first open end and a second open end, such that each open end is accessible for loading and unloading a storage device. The first open ends are accessible at a first plane of the two parallel planes and the second open ends are accessible at a second plane of the two parallel planes.

In another aspect, a storage device testing system is provided for testing storage devices. The storage device testing system includes a storage device transfer station for transferring storage devices from a human operator to automated machinery. The storage device transfer station includes a plurality of slots each capable of holding a storage device. The plurality of slots is arranged in at least one field arranged between two parallel planes. Each slot has a first open end and a second open end, such that each open end is accessible for loading and unloading a storage device. The first open ends are accessible at a first plane of the two parallel planes and the second open ends are accessible at a second plane of the two parallel planes. The storage device testing system also includes automated machinery configured to access the second open end of at least one of the plurality of slots.

According to another aspect, a method of testing storage devices includes manually loading a plurality of storage devices into a plurality of slots of a storage device transfer station; actuating automated machinery to transfer a plurality of the storage devices between the plurality of slots of the storage device transfer station and the plurality of slots of the storage device transfer station; and manually unloading a plurality of storage devices from a plurality of slots of the storage device transfer station.

Embodiments of the disclosed methods, systems and devices may include one or more of the following features.

The storage device transfer station can include at least one door covering at least a portion of the first plane. The door can be capable of locking and unlocking, including automatic locking and unlocking. At least one of the slots can have a stop, and the door can include resilient material or another mechanism arranged to push a storage device against the stop when the door is closed. The slots could be arranged to align a storage device in the horizontal or vertical directions.

In some implementations, the storage device transfer station has multiple doors covering the first plane.

In some embodiments, the plurality of slots could be arranged to receive a storage device at the first plane from a human operator, and the plurality of slots could be arranged to provide a storage device at the second plane to automated machinery.

In some configurations, the at least one field has at least 125 slots. In some configurations, the field has one or more vertically stacked rows. The slot could be arranged to prevent contact between a human operator and the automated machinery. In some embodiments, the storage device transfer station could have a door covering a portion of the first plane and configured to signal the automated machinery to restrict its movement while the door is open.

Methods can be carried out such that the automated machinery's movement is restricted while the plurality of storage devices is being manually loaded or unloaded. Methods can be carried out such that the manual loading of a plurality of storage devices into a plurality of slots of a storage device transfer station includes loading the storage devices into a subset of the slots of a storage device transfer station. Methods can include sorting the plurality of storage devices to group storage devices with substantially similar test results together.

Embodiments can include one or more of the following advantages.

Embodiments of the disclosed systems, methods, and devices can help to reduce human operator wait time associated with loading and unloading storage devices into/from a storage device testing system. For example, in some embodiments, a bulk load/unload transfer station can allow a human operator to load/unload many storage devices into a testing system at once, thereby freeing the operator to perform other tasks between load/unload operations.

A bulk load and/or unload system can also afford more opportunity to improve the handling of storage devices. For example, if one human operator loads many storage devices at once, e.g., sequentially during a single loading operation of limited duration, the number of opportunities to introduce storage device presentation errors is reduced as compared to loading storage devices continuously over an extended period of time.

A bulk load and/or unload system can also improve the efficiency of automated machinery, by allowing the automated machinery to load or unload storage devices

to/from many transfer station slots, without waiting for a human operator to remove or present a storage device to the automated machinery.

A bulk load and/or unload system can also allow for automated sorting of output storage devices into different fields, queues or containers.

5 In some embodiments, the disclosed systems, methods, and devices can allow a large number of storage devices to be queued for input and/or output.

Some embodiments do not require the use of any custom containers or totes to carry the storage devices. The cost of registering the storage devices in space and making the storage device presentation compatible with automated machinery is only incurred in
10 the feeding station, and not in every tote.

In some embodiments, the disclosed systems, methods, and devices provide means of achieving many of the benefits of a fully automated factory (e.g., reliability, repeatability, and density) using a manual, yet bulk oriented input/output station.

15 Bulk feeding of storage devices can help to provide for increased throughput by reducing the amount of human intervention.

Bulk feeding of storage devices can help to provide for increased throughput by limiting the amount of human intervention to discrete and spaced apart intervals of time. This can help to reduce presentation error by reducing the likelihood that an operator will lose attention or focus over time, e.g., as compared to a system in which an operator
20 continuously feeds storage devices into the system (or removes storage devices therefrom) over an extended period of time.

In some embodiments, many storage devices may be accessed at the same time. This makes the load/unload time very fast. In some embodiments, multiple operators could load and unload, further increasing efficiency.

25 In some embodiments, sorting or binning of storage devices is possible by the use of multiple doors. One door may enclose all passed storage devices while another encloses all failed storage devices. Any number of doors could be used.

Bulk feeding of storage devices in transfer stations is very space-efficient because no internal transport mechanisms are required. The depth of a transfer station can be as
30 little as the depth of a storage device. The lack of transport mechanisms also improves

the reliability of a transfer station compared to transfer stations with automated transport mechanisms.

Some embodiments use no moving parts.

Other aspects, features, and advantages are in the description, drawings, and
5 claims.

DESCRIPTION OF DRAWINGS

FIG. 1 is a perspective view of a storage device testing system and a transfer station.

FIG. 2 is a top view of a storage device testing system and a transfer station.

10 FIG. 3 is a perspective view of a storage device testing system and a transfer station.

FIGS. 4A and 4B are side views of a transfer station of a storage device testing system.

15 FIG. 5 is a perspective view of a storage device transporter and a storage device receptacle.

FIG. 6 is a top view of a storage device testing system and transfer stations.

FIG. 7 is a perspective view of a storage device being inserted into a test slot of a storage device testing system.

FIG. 8 is a perspective view of a storage device transporter.

20 FIG. 9 is a perspective view of a storage device transporter carrying a storage device.

FIG. 10 is a bottom perspective view of a storage device transporter carrying a storage device.

Like reference symbols in the various drawings indicate like elements.

25

DETAILED DESCRIPTION

System Overview

A storage device, as used herein, includes disk drives, solid state drives, memory devices, and any device that benefits from asynchronous processes in manufacturing or test. A disk drive is generally a non-volatile storage device that stores digitally encoded data on rapidly rotating platters with magnetic surfaces. A solid-state drive (SSD) is a data storage device that uses solid-state memory to store persistent data. An SSD using SRAM or DRAM (instead of flash memory) is often called a RAM-drive. The term solid-state generally distinguishes solid-state electronics from electromechanical devices.

Referring to FIGS. 1-3, in some implementations, a storage device testing system 100 includes at least one automated transporter 200 (e.g. robotic arm, gantry system, or multi-axis linear actuator) defining a first axis 205 (see FIG. 3) substantially normal to a floor surface 10. In the examples shown, the automated transporter 200 comprises a robotic arm 200 operable to rotate through a predetermined arc about the first axis 205 and to extend radially from the first axis 205. The robotic arm 200 is operable to rotate 360° about the first axis 205 and includes a manipulator 212 disposed at a distal end of the robotic arm 200 to handle a storage device 500 and/or a storage device transporter 550 carrying the storage device 500 (see e.g. FIGS. 8-10). Multiple racks 300 are arranged around the robotic arm 200 for servicing by the robotic arm 200. Each rack 300 houses multiple test slots 310 configured to receive storage devices 500 for testing. The robotic arm 200 defines a substantially cylindrical working envelope volume 210, with the racks 300 being arranged within the working envelope 210 for accessibility of each test slot 310 for servicing by the robotic arm 200. The substantially cylindrical working envelope volume 210 provides a compact footprint and is generally only limited in capacity by height constraints. In some examples, the robotic arm 200 is elevated by and supported on a pedestal or lift 250 (see FIG. 3) on the floor surface 10. The pedestal or lift 250 increases the size of the working envelope volume 210 by allowing the robotic arm 200 to reach not only upwardly, but also downwardly to service test slots 310. The size of the working envelope volume 210 can be further increased by adding a vertical actuator to the pedestal or lift 250.

The automated transporter 200 is configured to independently service each test slot 310 to provide a continuous flow of storage devices 500 through the testing system

100. A continuous flow of individual storage devices 500 through the testing system 100 allows varying start and stop times for each storage device 500, whereas other systems that require batches of storage devices 500 to be run all at once must all have the same start and end times. Therefore, with continuous flow, storage devices 500 of different capacities can be run at the same time and serviced (loaded/unloaded) as needed.

Referring to FIG. 3, the storage device testing system 100 includes a transfer station 400 configured for bulk feeding of storage devices 500 to the automated transporter 200. The automated transporter 200 independently services each test slot 310 by transferring a storage device 500 between the transfer station 400 and the test slot 310. The transfer station 400 has one or more access ports 410 each allowing an operator to load and unload multiple storage devices 500 presented for servicing by the automated transporter 200. The transfer station 400 is a service point for delivering and retrieving storage devices 500 to and from the storage device testing system 100. Each access port 410 allows an operator to deliver and retrieve a portion or all of a collection 600 of storage devices 500 to and from the transfer station 400. Storage devices 500 are accessible by an operator at an outer plane 402 (FIG. 2) of the transfer station 400 and accessible by an automated transporter 200 at an inner plane 404 (FIG. 2) of the transfer station 400. The outer plane 402 and inner plane 404 are substantially parallel to each other. Each collection 600 includes individual storage device receptacles 620 or slots into which the storage devices 500 are loaded and out of which the storage devices 500 are unloaded. Some implementations of the storage device receptacles are configured to receive storage device transporters 550 (see FIGS. 8-10) each containing storage devices 500.

In some implementations, a collection 600 may take the form of one or more vertically stacked rows of storage device receptacles 620. The number of storage device receptacles 620, and corresponding storage devices 500, could be as few as one or as many as 125 (e.g. 25 vertically stacked rows of 5) or more. In the example where the number of drives in the collection 600 is 125, an operator could load or unload the entire collection of drives in about ten minutes.

In some examples, an operator manually loads a plurality of storage devices 500 into the collection 600 in the transfer station 400. The robotic arm 200 may continuously unload the storage devices 500 and place them into test slots 310 for testing, and may also continuously transfer tested storage devices 500 from test slots 310 to storage device transfer station receptacles 620. During this time, the operator can leave and engage in other tasks, e.g., loading and unloading other storage devices 500 in a different transfer station 400 or testing system 100. Once a quantity of storage devices 500 have been tested and placed back into the transfer station 400, the operator can return to the transfer station 400 and unload the storage devices 500.

In the example shown in FIG. 3, each collection 600 is accessible from the inner plane 404 of the transfer station 400 in a presentation position and may be designated as a source collection 600 of storage devices 500 for testing or as a destination collection 600 of tested storage devices 500 (or both or some combination thereof). Destination collections 600 may be classified as “passed return collections” or “failed return collections” for receiving respective storage devices 500 that have either passed or failed a functionality test, respectively. Alternatively, in some implementations, a single collection 600 may contain storage devices 500 of multiple statuses and could be sorted according to status. For example, all of the storage devices 500 placed by the robotic arm 200 at one access port 410 associated with the collection 600 may all be drives that have passed the functionality test (or otherwise had substantially similar test results), while all of the storage devices 500 placed by the robotic arm 200 at another access port 410 associated with the collection 600 may all be drives that have failed the functionality test. In use, the storage devices 500 may be loaded by the robotic arm 200 into the storage device receptacles 620 of the collection 600 in a different order and arrangement than they were unloaded. Similarly, a storage device 500 unloaded by the robotic arm 200 from one collection 600 prior to testing may be loaded into a different collection 600 after testing. In some examples, a storage device 500 unloaded from one transfer station 400 prior to testing is loaded into another transfer station 400 after testing.

FIG. 4A shows a view of the outer plane 402 of the transfer station 400. A collection 600 of storage devices 500 is accessible at one or more access ports 410. In

some implementations, each access port 410 may provide access to the entire collection 600 or a subset or portion of the collection. The collection 600 of storage devices 500 can be arranged so that an open end 624 of each storage device receptacle 620 accessible at the access port 410 is accessible for loading and unloading a storage device 500.

5 In some implementations, multiple access ports 410 are available in proximity to each other. For example, multiple access ports 410 can be arranged in a vertical column 414, as shown, or arranged in a different configuration, such as a horizontal row, a combination of rows or columns, or another configuration of access ports 410. In implementations where an access port 410 provides access to a portion of a collection
10 600, the combination of multiple access ports 410 may provide access to the entire collection 600.

 In some implementations, the access ports 410 are arranged to be accessible to a human operator 640. The human operator can load and unload storage devices 500 directly into the storage device receptacles 620 of the collection 600 of storage devices.
15 The access ports 410 can be arranged to be suitable for human use, for example, arranged to account for ergonomic factors. For example, the access ports 410 can be arranged within the field of reach of a human operator 640. For example, the in the exemplary configuration of a vertical column 414 of access ports 410, the lower edge 416 of the lowest access port could be a height 630 of about 50 centimeters off of the ground. The
20 upper edge 418 of the highest access port could be a height 632 of about 200 centimeters off of the ground.

 In some implementations, more than one human operator 640 can access the same access port 410 simultaneously, for example, to speed up workflow and load or unload more storage devices 500 in a shorter amount of time.

25 In some implementations, the size and construction of the collection 600 and the storage device receptacles 620 is such that a robotic arm 200 does not come in contact with a human operator 640. For example, the storage device receptacles 620 can be long enough to provide a buffer of space between the portion accessible to the robotic arm 200 and the portion accessible to the human operator 640.

An access port 410 may have an optional door 412 that can be opened and closed by a human operator 640. FIG. 4B shows another view of the outer plane 402 of the transfer station 400 in which the door 412 is closed, blocking the collection 600 of storage devices 500 from access. In some implementations, the door 412 can be used to protect the storage devices 500 within from external factors, such as heat, light, and dust, or to isolate the interior of the storage device testing system 100 from the surrounding environment. For example, the human operator might keep the door 412 closed at all times except when loading or unloading storage devices 500 from the associated access port 410 to protect the drives from those factors.

In some implementations, the status of the door 412 can determine actions of the robotic arm 200. For example, the robotic arm 200 can be configured to refrain from loading or unloading storage devices 500 from the portion of the collection 600 associated with the door 412 when the door is open, indicating that a human operator 640 is in the process of loading or unloading some of the storage devices. Similarly, the robotic arm 200 can be configured to resume loading and unloading storage devices 500 when the door 412 is closed. Alternatively, the robotic arm 200 can be configured to cease all motion while the door 412 is open.

In some implementations, the door 412 can also be locked and unlocked. For example, the locking capability can be used to control access to the collection 600 associated with the door. For example, all doors may be kept locked until such time that the collection 600 associated with a door 412 is ready for service by a human operator. For example, a collection behind a particular door 412 may contain untested storage devices 500. In such a case, the door 412 may be kept locked until all storage devices 500 have been transferred to test slots 310. When all storage devices 500 have been transferred, the door 412 may be automatically unlocked by the system, to allow a human operator 640 to load new untested storage devices 500. In another example, the collection 600 associated with a door 412 may contain tested storage devices 500 that have passed a functionality test. When a human operator 640 requests access to passed storage devices, the system may unlock only that door 412 covering the part of the collection 600 that

consists of passed storage devices. This prevents the human operator 640 from inadvertently removing storage devices from some other part of the collection 600.

FIG. 4B also shows status indicators 430 associated with a door 412. The status indicators 430 can provide information to a nearby human operator 640 about the storage devices 500 in the portion of the collection 600 behind the door. For example, the status indicators 430 may indicate that the storage devices 500 behind the door 412 have been tested, or that some or all of the storage devices 500 are still awaiting testing. In another example, the status indicators 430 may indicate which storage device receptacles 620 behind the door 412 contain storage devices 500 and which storage device receptacles 620 behind the door 412 do not contain storage devices 500. Further, in situations where the storage devices 500 have been tested, the status indicators 430 may indicate whether the storage devices 500 have passed the testing and are considered “good output,” or that the storage devices 500 have failed the testing and are considered “bad output.” In implementations in which the door 412 is capable of locking and unlocking, the status indicators 430 may indicate whether the door 412 is locked or unlocked. In some implementations, the status indicators 430 may be combined with pushbuttons. In these implementations, pushing a button may signal to the system that the human operator is requesting access to the storage devices 500 behind the associated door 412.

The status indicators 430 may take the form of lights (e.g. light-emitting diodes) that light up or flash, for example. In some implementations, the status indicators may be part of an alphanumeric display, for example, a liquid-crystal display.

In some implementations, the door 412 may have a display screen 432 instead of or in addition to the status indicators 430. The display screen 432 may provide additional information or more details than would be relayed by the status indicators 430 (if present). For example, the display screen 432 may allow a human operator 640 to access or modify the configuration of the transfer station 400 or the entire testing system. The display screen 432 may be a touch screen, for example, or may have another type of associated control system such as a keyboard and mouse.

In some implementations, the transfer station 400 has a master status indicator 434 that indicates general information to one or more human operators 640 in the

vicinity, for example, whether the transfer station 400 or the storage device testing system 100 have encountered errors requiring human intervention or repair.

FIG. 5 shows an implementation of the storage device receptacle 620 that has an integrated stop 626. The stop 626 prevents a storage device 500 or, in the implementation shown, storage device transporter 550, from being pushed too far into the storage device receptacle 620 when the storage device or transporter is loaded. In some implementations, the door 412 may be made of or may include resilient material that pushes 628 the storage devices 500 in the collection 600 behind the door against the stop in their respective storage device receptacles 620 when the door is closed. In some implementations, the door 412 may include other mechanisms for pushing the storage devices 500 in the collection 600 behind the door against the stop, for example mechanisms that use springs, rigid mechanical members, or dashpots. Also, in some implementations, the stop 626 or another component of the storage device receptacle 620 is constructed to horizontally and vertically align a storage device 500 when the storage device is inserted in the receptacle, for example, in functional cooperation with the pushing mechanism of the door.

In some implementations, the door 412, the storage device receptacle 620, or another element of the testing system 100 may have one or more detectors configured to detect the presence and absence of storage devices 500 within the storage device receptacles 620 of the collection 600. For example, the detector could be integrated with the stop 626, or the detector may be a separate component. The information supplied by the detector may be used by the status indicators 430 or display screen 432 to indicate the presence or absence of the storage devices 500. In some implementations, the robotic arm 200 may incorporate functionality to detect the presence or absence of a storage device 500 within the storage device receptacles 620, for example a camera, bar code scanner, or laser rangefinder.

As shown in FIG. 6, in some implementations, a human operator 640 and the robotic arm 200 can perform activities simultaneously. For example, the storage device testing system 100 may have multiple transfer stations 400a, 400b. In one exemplary scenario, the human operator has, using an access port 410 at the outer plane 402, loaded

storage devices 500 into one transfer station 400a for testing. The robotic arm 200 now unloads the storage devices, which are also accessible at the inner plane 404, for testing. At the same time as the robotic arm 200 unloads storage devices 500, the human operator 640 can load other storage devices into the other transfer station 400b. In another
5 exemplary scenario, the robotic arm has already loaded tested storage devices 500 into the other transfer station 400b, which the human operator 640 unloads while the robotic arm 200 loads or unloads storage devices 500 in the first transfer station 400a. In other scenarios, the human operator 640 and the robotic arm 200 each load or unload drives from different collections 600 in the same transfer station 400, or different portions of the
10 same collection 600. Other scenarios in which the human operator 640 and the robotic arm 200 operate simultaneously are possible.

In implementations that employ storage device transporters 550 for manipulating storage devices 500, as shown in FIG. 7, the automated transporter 200 is configured to remove a storage device transporter 550 from one of the test slots 310 with the
15 manipulator 212, then pick up a storage device 500 from one the collections 600 presented at the transfer station 400 with the storage device transporter 550, and then return the storage device transporter 550, with a storage device 500 therein, to the test slot 310 for testing of the storage device 500. After testing, the automated transporter 200 retrieves the tested storage device 500 from the test slot 310, by removing the storage
20 device transporter 550 carrying the tested storage device 500 from the test slot 310 (i.e., with the manipulator 212), carrying the tested storage device 500 in the storage device transporter 550 to the transfer station 400, and manipulating the storage device transporter 550 to return the tested storage device 500 to one of the collections 600 at the transfer station 400.

25 The test slot 310, shown in FIG. 7, defines an opening 312 configured to receive the storage device transporter 550, which in this case provides closure of the test slot 310. The storage device transporter 550 is configured to receive the storage device 500, as shown in FIG. 8, and be handled by the automated transporter 200. In use, one of the storage device transporters 550 is removed from one of the test slots 310 with the robotic
30 arm 200 (e.g., by grabbing, or otherwise engaging, the indentation 552 of the transporter

550 with the manipulator 212 of the robot 200). In some examples, as illustrated in FIGS. 8-10, the storage device transporter 550 includes a frame 560 defining a substantially U-shaped opening 561 formed by sidewalls 562, 564 and a base plate 566 that collectively allow the frame 560 to fit around a storage device support (not shown) in the collection 600 so that the storage device transporter 550 can be moved (e.g., via the robotic arm 200) into a position beneath one of the storage devices 500 housed in one of multiple storage device receptacles 620 defined by the collection 600 (see e.g., FIG. 3). The storage device transporter 550 can then be raised (e.g., by the robotic arm 200) into a position engaging the storage device 500 for removal from the collection 600.

10 With the storage device 500 in place within the frame 560 of the storage device transporter 550, the storage device transporter 550 and the storage device 500 together can be moved by the automated transporter 200 for placement within one of the test slots 310, as shown in FIG. 4. In some implementations, the manipulator 212 is also configured to initiate actuation of a clamping mechanism 570 disposed in the storage device transporter 550. This allows actuation of the clamping mechanism 570 before the transporter 550 is moved from the collection 600 to the test slot 310 to inhibit movement of the storage device 500 relative to the storage device transporter 550 during the move. Prior to insertion in the test slot 310, the manipulator 212 can again actuate the clamping mechanism 570 to release the storage device 500 within the frame 560. This allows for insertion of the storage device transporter 550 into one of the test slots 310, until the storage device 500 is in a test position with a storage device connector 510 engaged with a test slot connector (not shown). The clamping mechanism 570 may also be configured to engage the test slot 310, once received therein, to inhibit movement of the storage device transporter 550 relative to the test slot 310. In such implementations, once the storage device 500 is in the test position, the clamping mechanism 570 is engaged again (e.g., by the manipulator 212) to inhibit movement of the storage device transporter 550 relative to the test slot 310. The clamping of the transporter 550 in this manner can help to reduce vibrations during testing. In some examples, after insertion, the storage device transporter 550 and storage device 500 carried therein are both clamped or secured in combination or individually within the test slot 310.

A detailed description of the robotic arm 200, test slots 310 and other details and features combinable with those described herein may be found in the following U.S. patent applications, entitled “Disk Drive Testing”, having assigned serial number 11/958,817, entitled “Bulk Feeding Disk Drives To Disk Drive Testing Systems”, having
5 assigned serial number 12/104,869, and entitled “Bulk Transfer of Storage Devices Using Manual Loading”, having assigned serial number 61/316,667, the entire contents of the aforementioned applications are hereby incorporated by reference.

Other embodiments are within the scope of the following claims.

WHAT IS CLAIMED IS:

1. A storage device transfer station, comprising:
a plurality of slots each capable of holding a storage device, the plurality of slots arranged in at least one field between two parallel planes,
each slot having a first open end and a second open end, each open end being accessible for loading and unloading a storage device,
the first open ends being accessible at a first plane of the two parallel planes and the second open ends being accessible at a second plane of the two parallel planes.
2. The storage device transfer station of claim 1, further comprising at least one door covering at least a portion of the first plane.
3. The storage device transfer station of claim 2, wherein the door is capable of locking and unlocking.
4. The storage device transfer station of claim 3, wherein the door is capable of automatic locking and unlocking.
5. The storage device transfer station of claim 1, further comprising a plurality of doors, wherein the first plane is covered by the plurality of doors.
6. The storage device transfer station of claim 1, wherein at least one of the slots is arranged to align a storage device in at least one of the vertical and horizontal directions.
7. The storage device transfer station of claim 2, wherein at least one of the slots comprises a stop.

8. The storage device transfer station of claim 7, wherein the door comprises a mechanism to push a storage device against the stop when the door is closed.

9. The storage device transfer station of claim 1, wherein the plurality of slots are arranged to receive a storage device at the first plane from a human operator.

10. The storage device transfer station of claim 1, wherein the plurality of slots are arranged to provide a storage device at the second plane to automated machinery.

11. The storage device transfer station of claim 1, wherein the plurality of slots are arranged to prevent contact between a human operator and the automated machinery.

12. The storage device transfer station of claim 1, further comprising at least one door covering at least a portion of the first plane, and configured to signal the automated machinery to restrict its movement while the at least one door is open.

13. The storage device transfer station of claim 1, wherein the at least one field comprises at least 125 slots.

14. The storage device transfer station of claim 1, wherein the field comprises one or more vertically stacked rows.

15. A storage device testing system, comprising:

a storage device transfer station comprising

a plurality of slots each capable of holding a storage device, the plurality of slots arranged in a field arranged between two parallel planes, each slot having a first open end and a second open end, each open end being accessible for loading and unloading a storage device,

the first open ends being accessible at a first plane of the two parallel planes and the second open ends being accessible at a second plane of the two parallel planes; and

automated machinery configured to access the second open end of at least one of the plurality of slots.

16. The storage device testing system of claim 15, further comprising at least one door covering at least a portion of the first plane.

17. The storage device transfer station of claim 16, wherein the at least one door is configured to signal the automated machinery to restrict its movement while the at least one door is open.

18. The storage device testing system of claim 16, wherein the door is capable of locking and unlocking.

19. The storage device testing system of claim 18, wherein the door is capable of automatic locking and unlocking.

20. The storage device testing system of claim 15, wherein the storage device transfer station further comprises a plurality of doors, and wherein the first plane is covered by the plurality of doors.

21. The storage device testing system of claim 15, wherein at least one of the slots is arranged to align a storage device in at least one of the vertical and horizontal directions.

22. The storage device testing system of claim 16, wherein at least one of the slots comprises a stop.

23. The storage device testing system of claim 22, wherein the door comprises a mechanism to push a storage device against the stop when the door is closed.

24. The storage device testing system of claim 15, wherein the plurality of slots is arranged to receive a storage device at the first plane from a human operator.

25. The storage device transfer station of claim 15, wherein each slot is arranged to prevent contact between a human operator and the automated machinery.

26. The storage device testing system of claim 15, wherein the at least one field comprises at least 125 slots.

27. The storage device testing system of claim 15, wherein the field comprises one or more vertically stacked rows.

28. A method of testing storage devices, comprising:
manually loading a plurality of storage devices into a plurality of slots of a storage device transfer station;

actuating automated machinery to transfer a plurality of storage devices between the plurality of slots of the storage device transfer station and the plurality of slots of the storage device testing system; and

manually unloading a plurality of storage devices from the plurality of slots of the storage device transfer station.

29. The method of claim 28, wherein the automated machinery's movement is restricted while the plurality of storage devices is being manually loaded or unloaded.

30. The method of claim 28, wherein the manual loading of a plurality of storage devices into a plurality of slots of a storage device transfer station comprises loading the storage devices into a subset of the slots of a storage device transfer station.

31. The method of claim 28, wherein the transfer of a plurality of storage devices from the plurality of slots of the storage device testing system to the plurality of slots of the storage device transfer station comprises sorting the plurality of storage devices to group storage devices with substantially similar test results together.

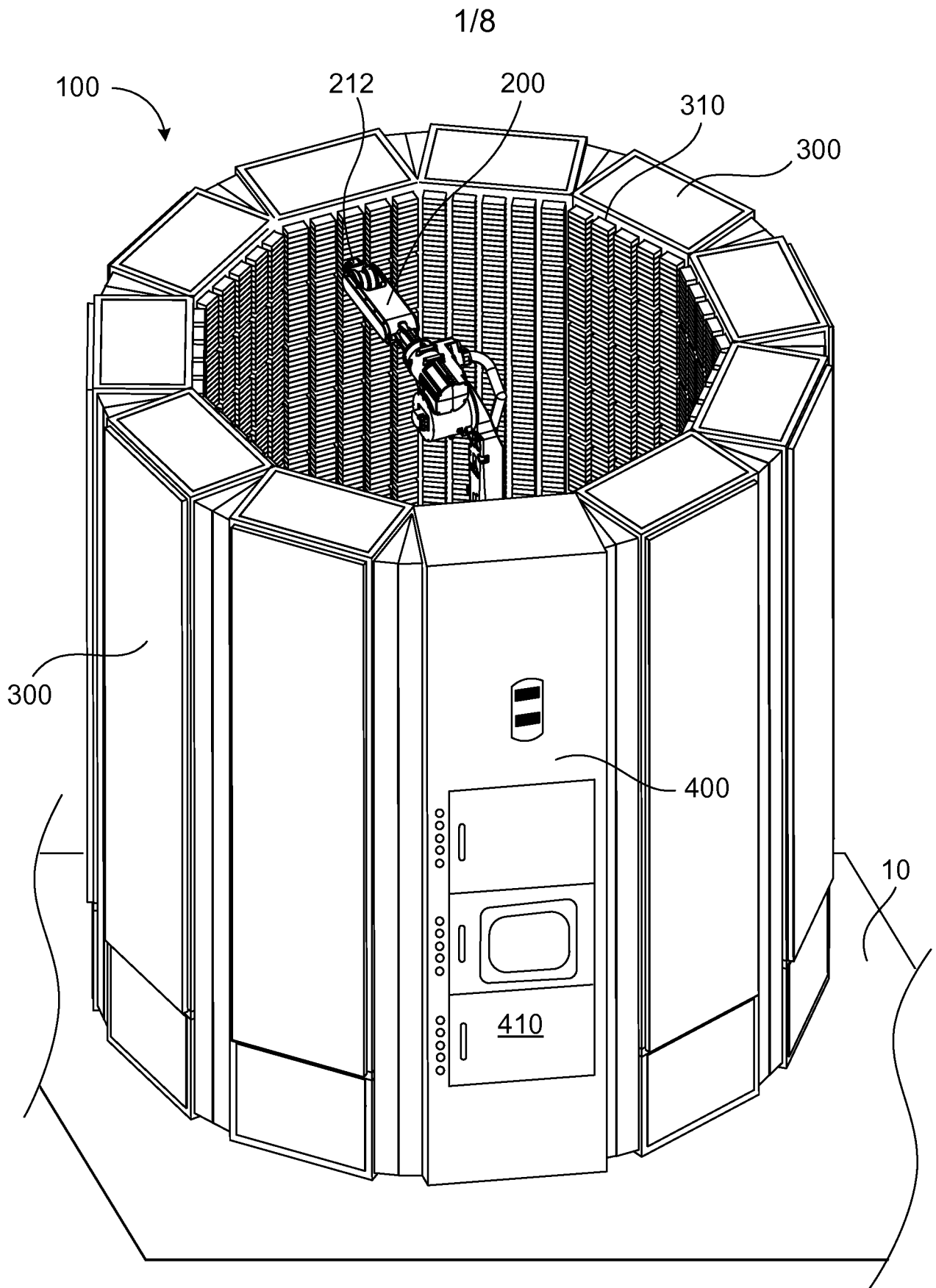

FIG. 1

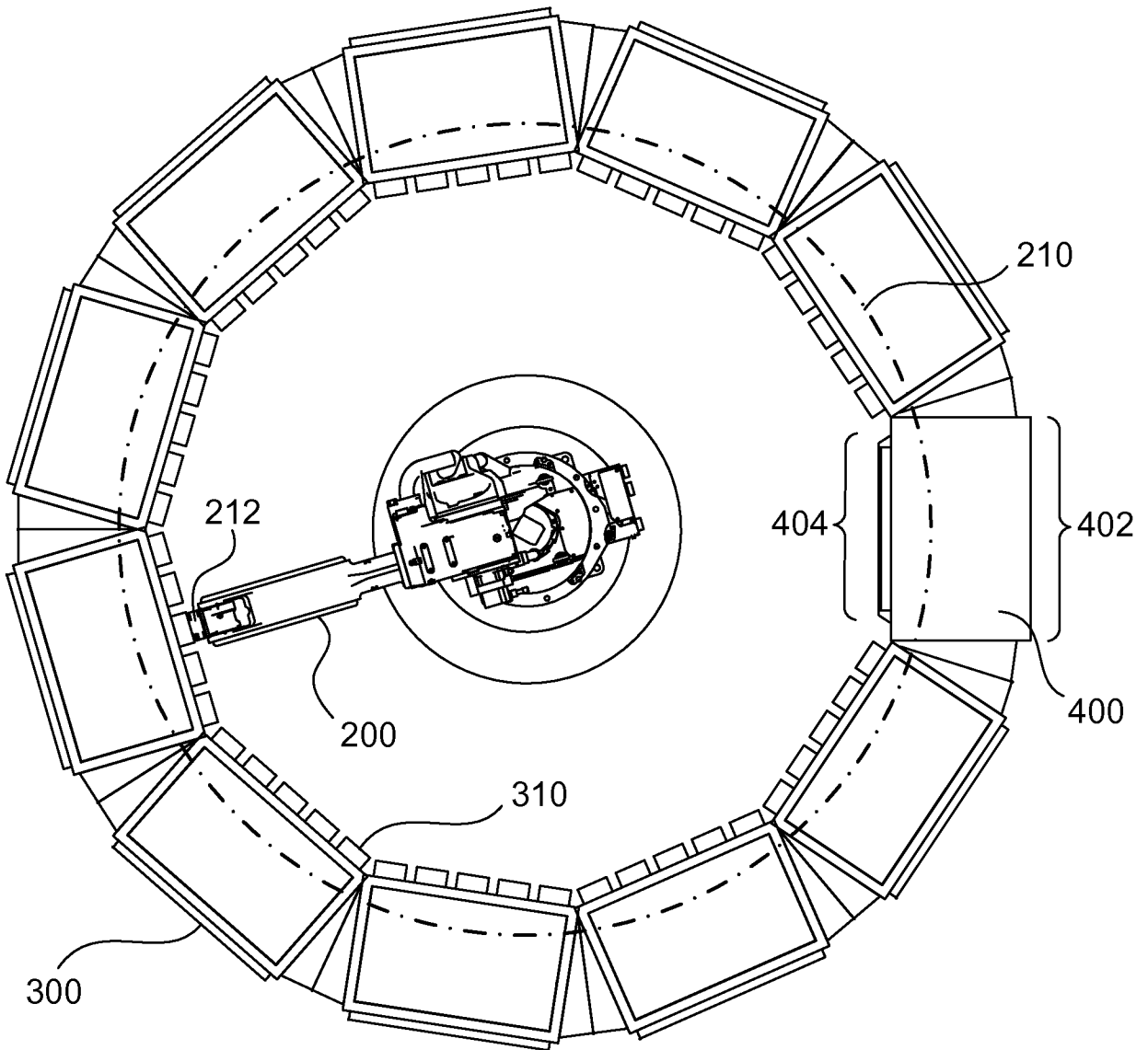

FIG. 2

3/8

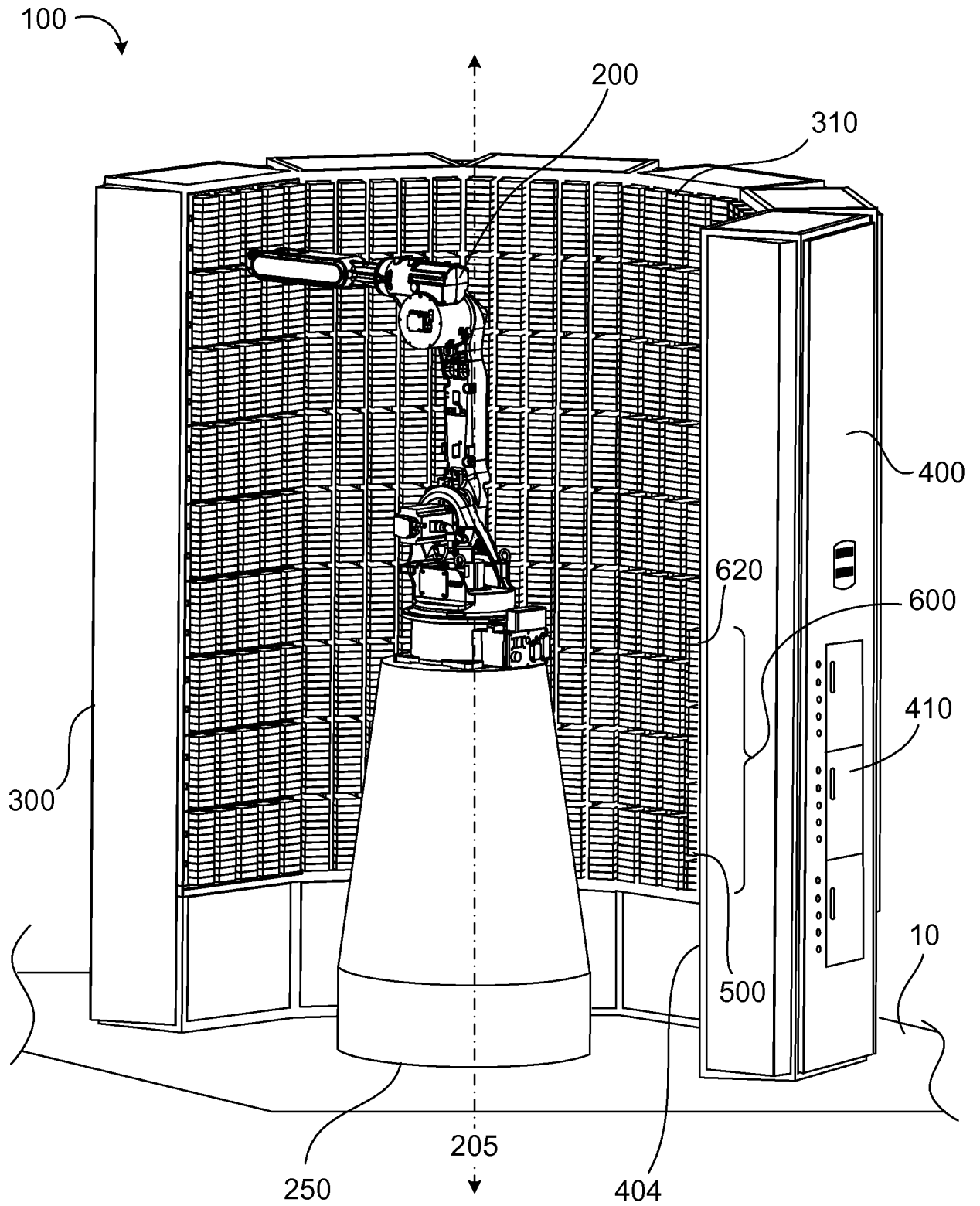

FIG. 3

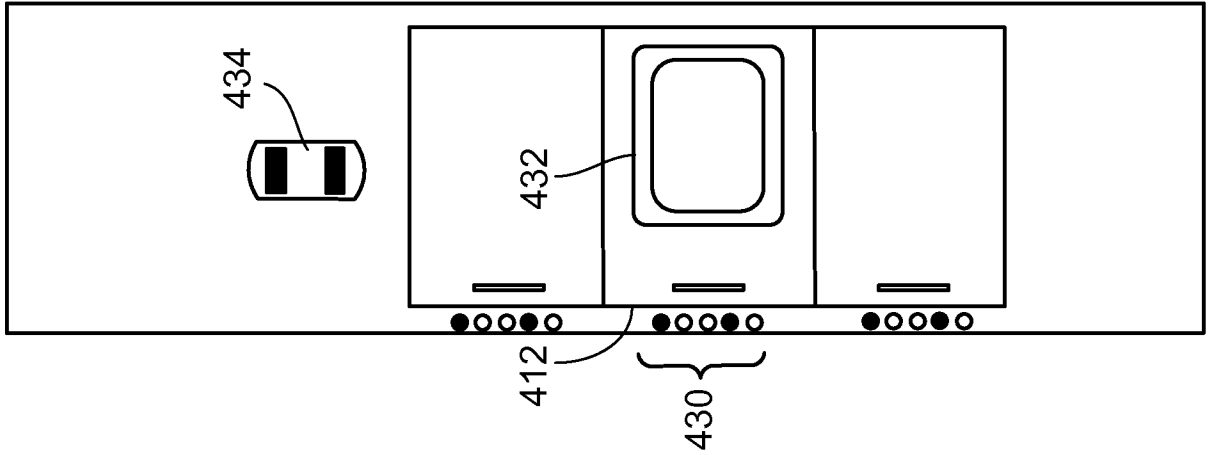

FIG. 4B

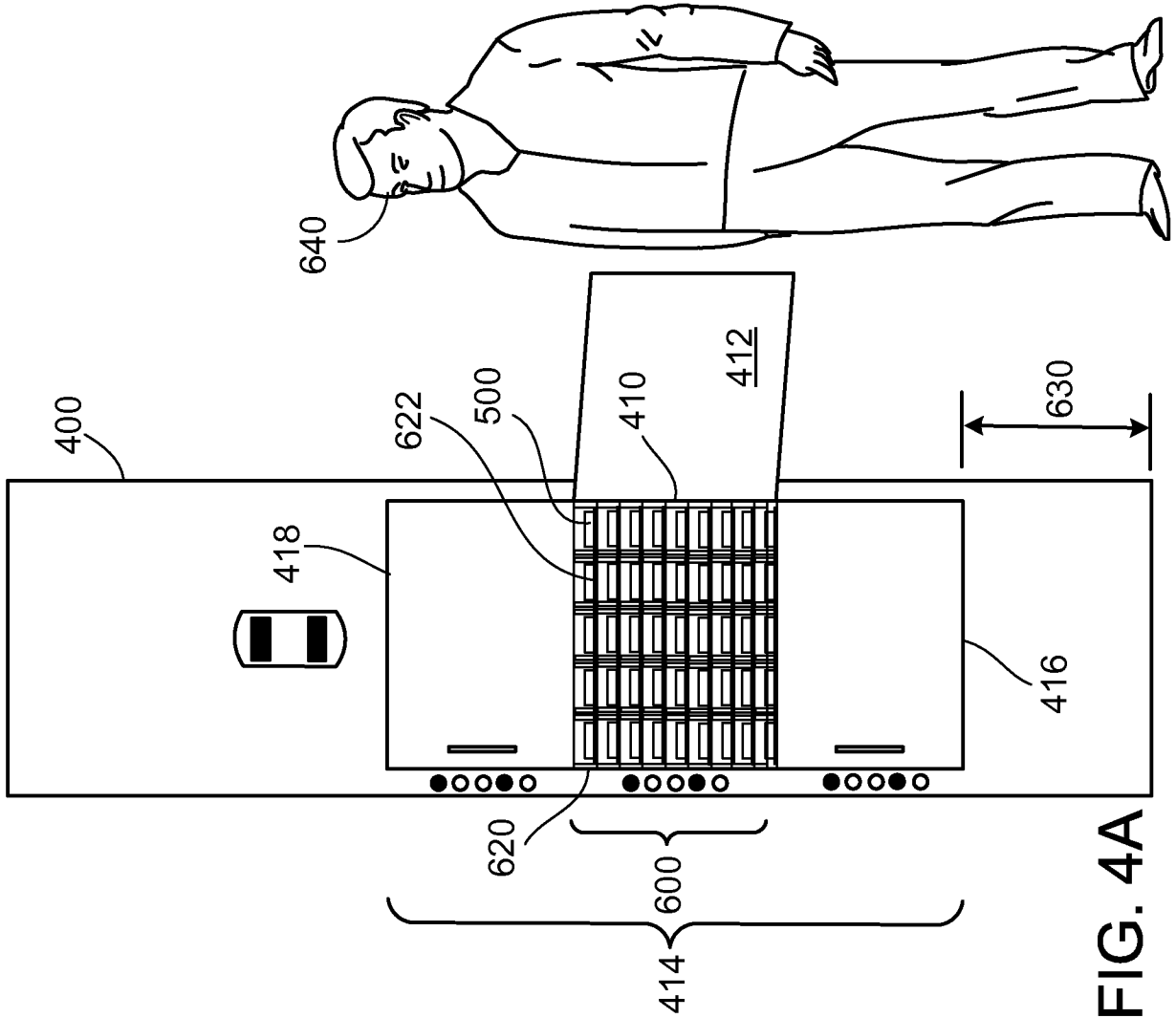

FIG. 4A

5/8

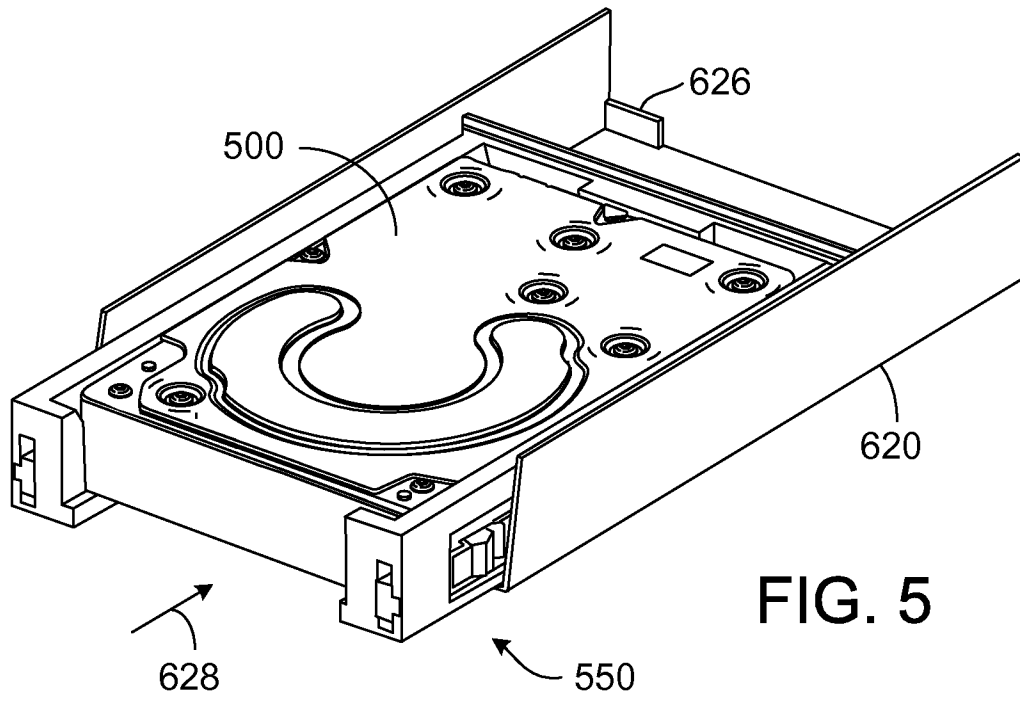

FIG. 5

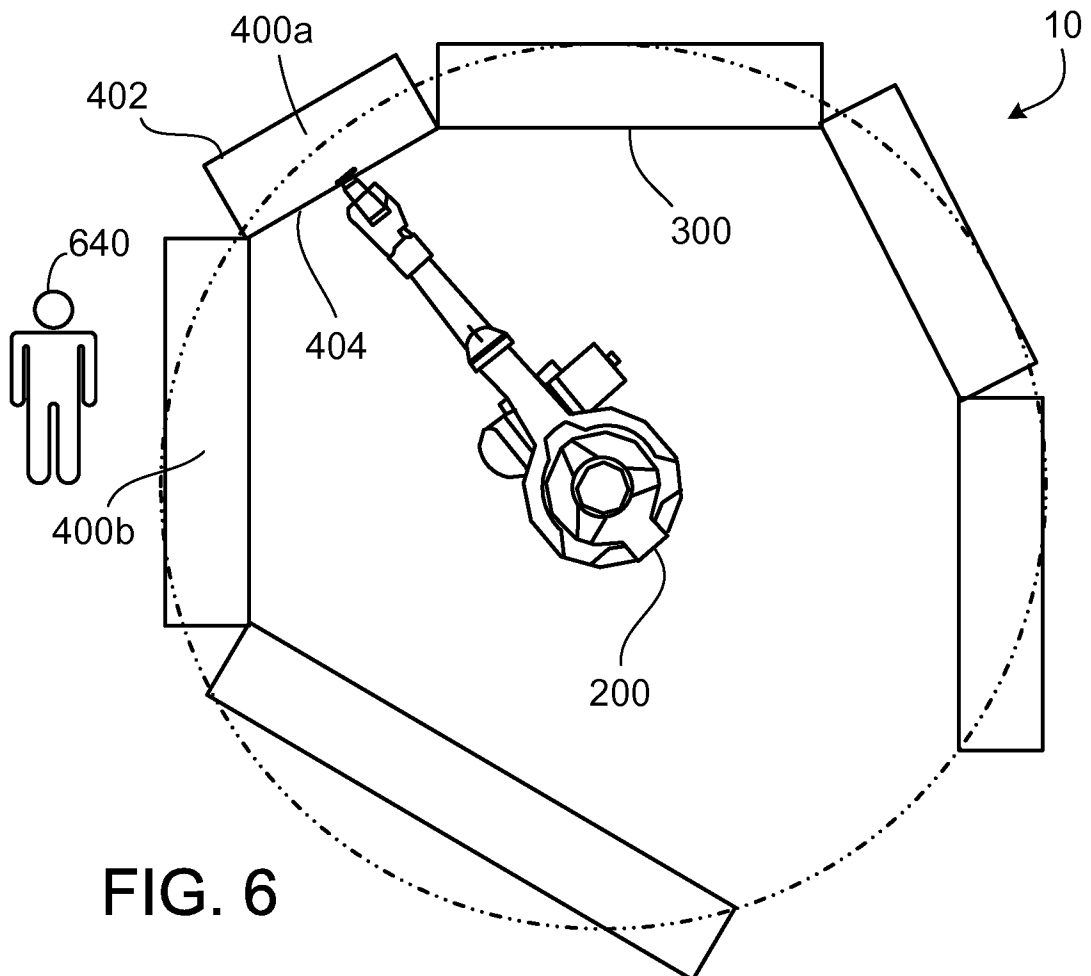
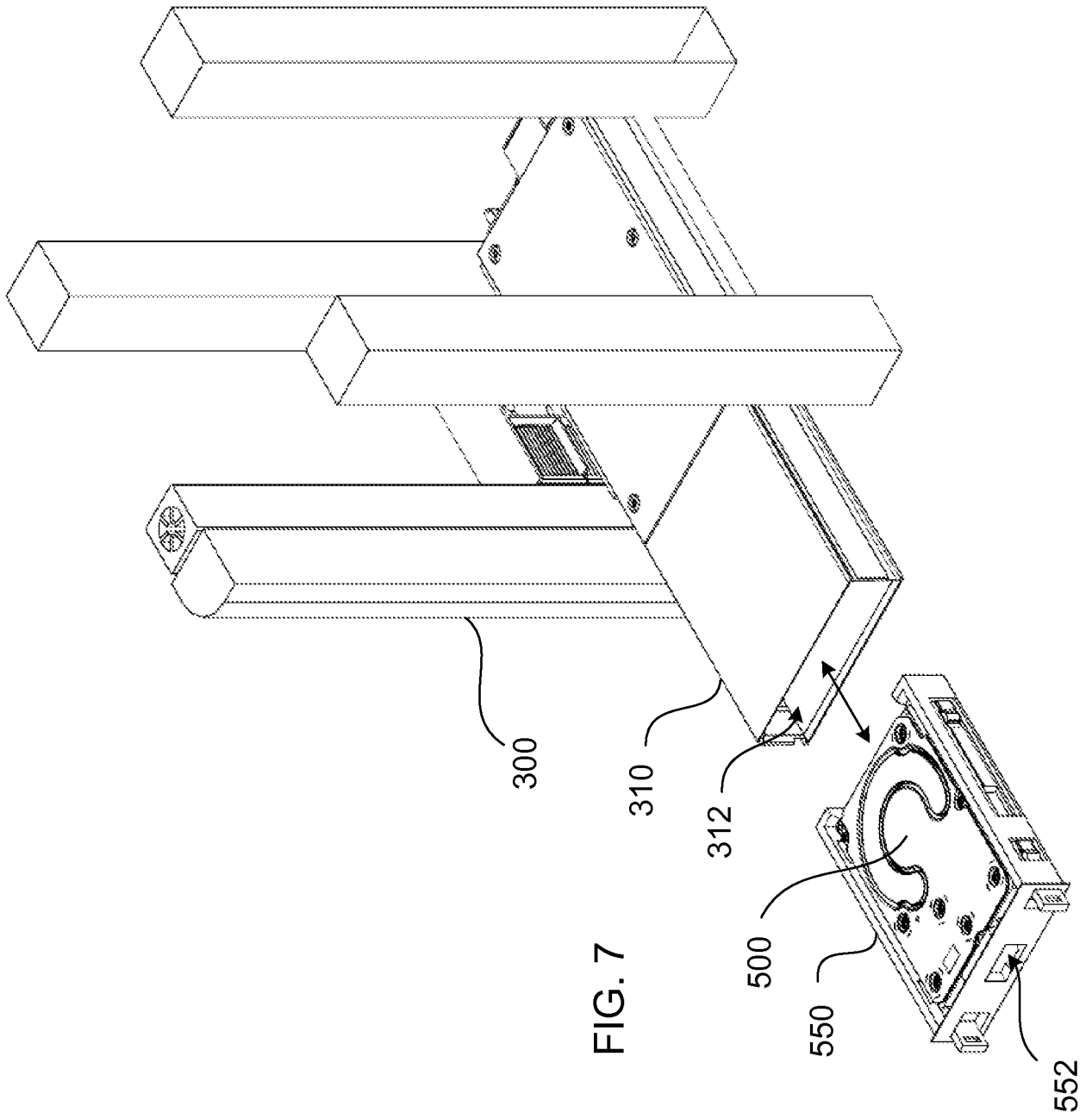

FIG. 6



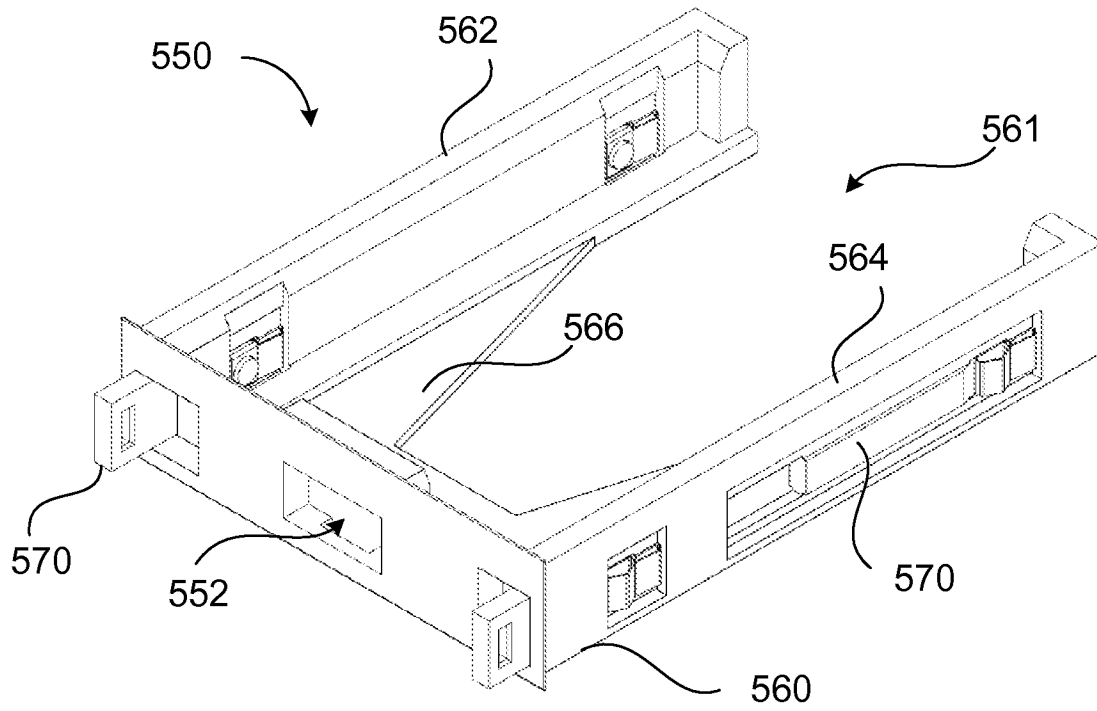

FIG. 8

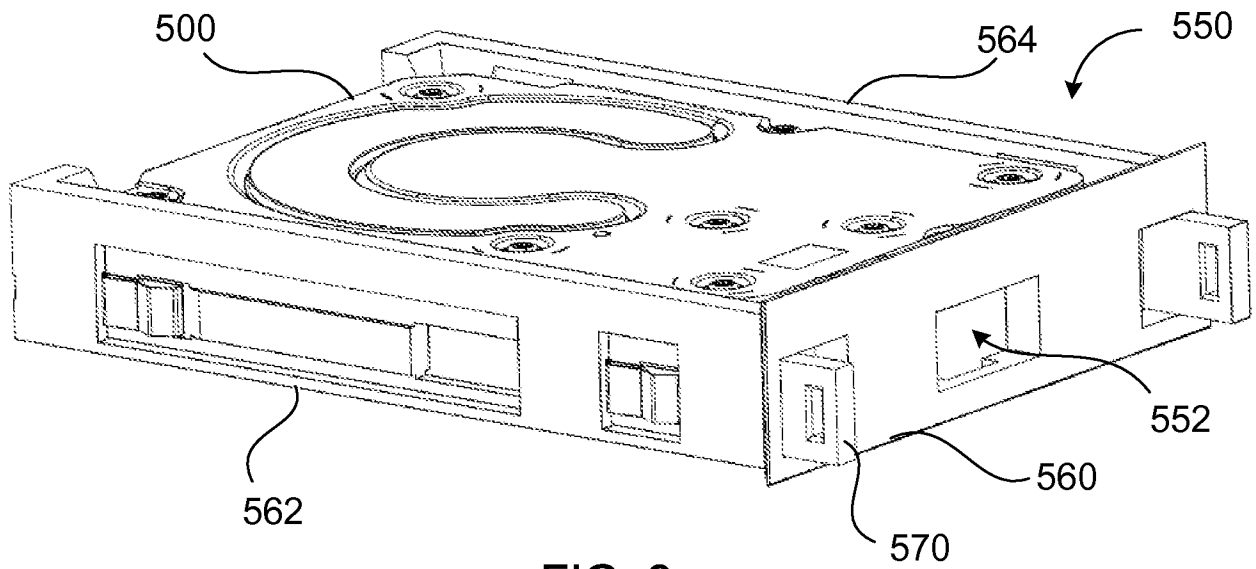

FIG. 9

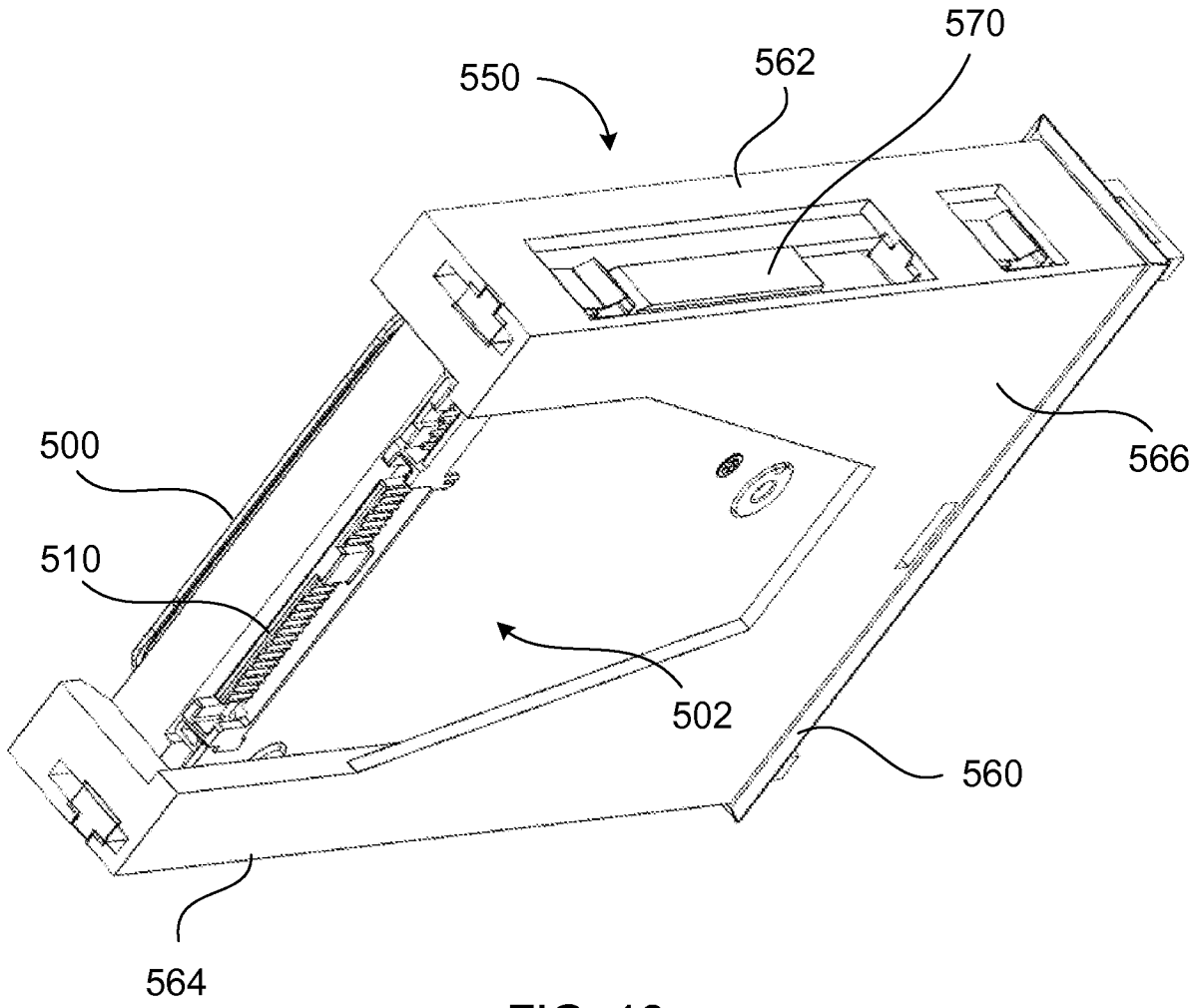

FIG. 10