

M. LEBLANC.
 AIR PUMP.
 APPLICATION FILED SEPT. 14, 1909.

1,198,640.

Patented Sept. 19, 1916.

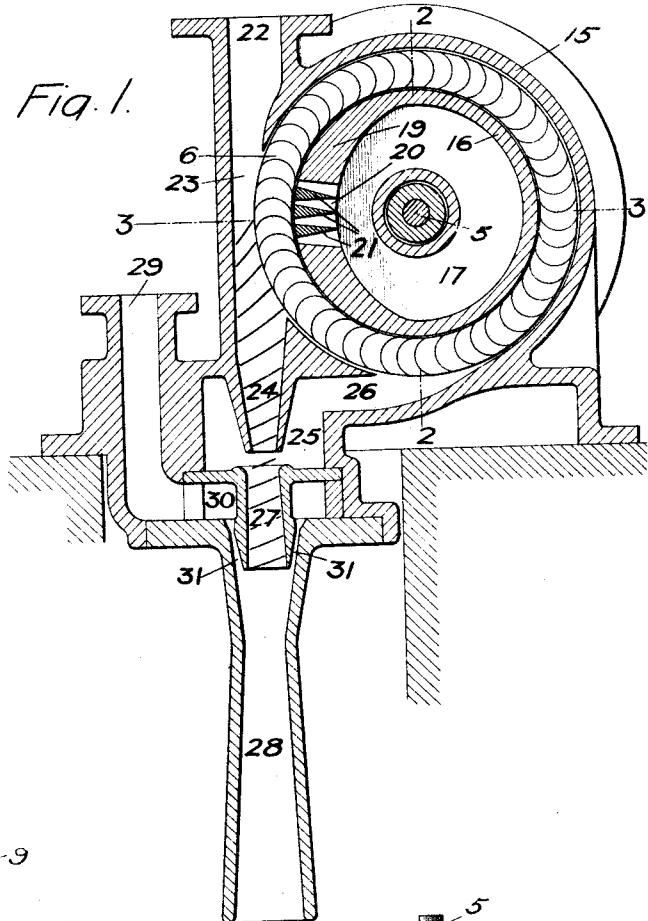

Fig. 1.

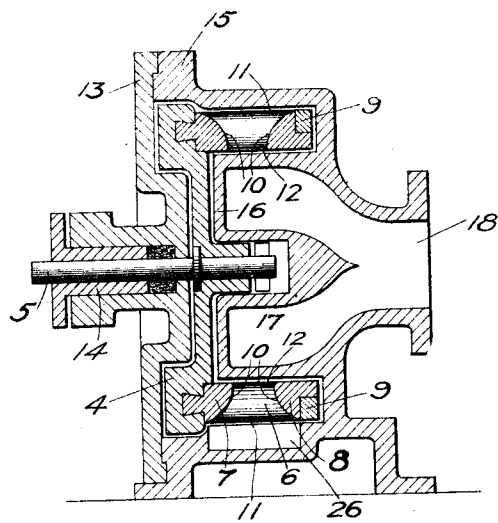

Fig. 2.

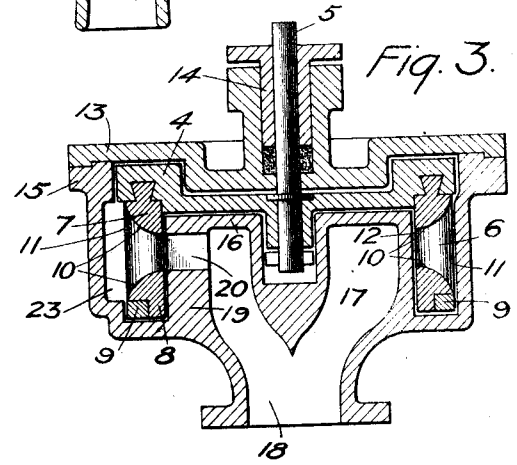

Fig. 3.

WITNESSES:
R. G. Davis
Geo. Walker

INVENTOR.
 BY *Maurice L. Blane*
Geo. S. Blane
 HIS ATTORNEY IN FACT.

UNITED STATES PATENT OFFICE.

MAURICE LEBLANC, OF PARIS, FRANCE.

AIR-PUMP.

1,198,640.

Specification of Letters Patent. Patented Sept. 19, 1916.

Application filed September 14, 1909. Serial No. 517,691.

To all whom it may concern:

Be it known that I, MAURICE LEBLANC, a citizen of the Republic of France, residing at Villa Montmorency, Auteuil, Paris, France, have made a new and useful invention in Air-Pumps, of which the following is a specification.

This invention relates to air or other elastic fluid pumps.

In my Patent No. 984,278 of February 14, 1911, I have illustrated a condensing apparatus employing a condensing chamber communicating with a source of fluid to be condensed and provided with a discharge port which communicates with a condenser. The apparatus of the patent also includes a liquid translating device illustrated as a partial injection bladed impeller and adapted to mechanically project a stream or jet of condensing liquid through the chamber at a high velocity, for the purpose of condensing the condensable vapors within the chamber and of removing the non-condensable gases therefrom. The bladed impeller together with its distributing nozzle are so located and arranged that the liquid projected into the chamber traverses it in a sub-divided state and is finally collected by the converging walls of the chamber and delivered, by reason of its own velocity, through the outlet of the chamber and the diffuser. This apparatus is broadly claimed in said patent. While the apparatus of this patent is efficient for the purposes of condensing apparatus, its efficiency as an air or other elastic fluid pump is not such as might be desired, since the parts are not so proportioned that the propelled or projected liquid traversing the chamber will maintain a leaf or film formation and completely fill or bridge the portion of the chamber through which it passes.

An object of this invention is to produce a highly efficient air or other elastic fluid pump utilizing a fluid translating device employing the principle of the one disclosed in said application.

In the drawings forming a part of this application and throughout which similar parts are denoted by like characters: Figure 1 is a vertical sectional view of an air pump embodying this invention; Fig. 2 is a cross-sectional view taken on line 2—2 of Fig. 1; and Fig. 3 is a cross-sectional view taken on line 3—3 of Fig. 1.

The pump consists of a rotor element composed of a plate or disk 4 mounted upon a shaft 5 and provided with an annular row of axially-extending blades or buckets 6. The blades are provided with shrouds 7 and 8 for their opposite ends, and, shrunk into a recess provided in the outer shrouds, is a retainer ring 9. The adjacent faces 10—10 of the shrouds are preferably curved as illustrated in Figs. 2 and 3 so that the discharge edges 11 of the blades are materially longer than the inlet edges 12. This allows the water entering the spaces between the blades to spread out on the blades into thin films. The effective length, therefore, of the blades is the same as the discharge edges of the blades.

A casing surrounds the rotor and is composed of an end plate 13 provided with a stuffing box 14 at its center through which the shaft 5 passes. The other portion 15 of the casing surrounds the rotor and has a portion 16 which extends within the row of blades and is formed with a chamber 17 provided with a water inlet 18. The wall of the chamber 17 at 19 is thickened as shown in Figs. 1 and 3 and through this thickened portion an outlet 20 for water extends. This outlet which I will term the distributor, is provided with a number (in Fig. 1, three) of directing vanes 21 which form nozzles or spouts.

The portion 15 of the outer casing is provided with an air inlet 22 to a passage or conduit 23 into which the blades of the rotor extend. The conduit at the point where the blades enter the same is rectilinear in cross-section and is of the same width as the effective length of the blades; that is, the same width as the length of the discharge edges 11 of the blades. The conduit 23 terminates in a converging combining and collecting chamber or tube 24. An equalizing chamber 25 is formed in the portion 15 surrounding the outlet end of the tube 24 and is placed in communication with the wheel chamber by means of a passage 26 formed in said portion 15.

Axially in line with the collecting tube 24 is a diffuser made up of a cone 27 and the diffuser proper 28. An inlet 29 for steam communicates with a chamber 30 which surrounds cone 27 and an annular passage 31 lies between cone 27 and the diffuser proper. The shaft 5 may be rotated at the desired speed by any suitable

means, such as an electric motor, a steam turbine or a reciprocating engine.

Water inlet 18 will be connected by means of piping to any suitable source of water supply and inlet 22 by means of suitable piping will be connected to the point from which air or other elastic fluid is to be pumped. This point may be a surface condenser, a jet condenser, a barometric condenser or, in fact, any chamber or vessel from which it is desired to withdraw the elastic fluid contained therein or supplied thereto. Inlet 29 will be connected by means of suitable valved piping with a suitable source of steam supply.

In operation, assuming that the motor is rotating at the proper speed, in order to prime the pump, steam is admitted through inlet 29 and by means of the ejector device comprising cone 27 and chamber 30 and passage 31, the pressure in chamber 25 will be lowered and water will be forced in through inlet 18 into chamber 17 and through the distributor nozzles to the blades. The blades rotating past the distributor nozzles will project the water into and through passage or conduit 23 toward and through the collecting tube 24. On account of the high speed of travel of the blades past the distributor, each blade will receive but a small amount of water which will be flattened out against the blade and projected therefrom in the form of a film, piston or leaf which will substantially bridge or fill the conduit as a piston fills a cylinder. As the blades move in succession past the distributor, a stream or jet formed of a succession of these leaves or pistons will move at high velocity through the conduit or chamber 23 and toward and through the collecting chamber like a succession of pistons. Upon issuing from the collecting chamber, the stream formed of the leaves, films or pistons will pass into and through the diffuser. On account of the chamber 25, which surrounds the outlet of the collecting tube and passage 26, it will be seen that the pressure of the fluid leaving the collecting tube will be the same as the pressure of the fluid entering inlet 22. As the leaves or films of water projected by the blades are projected across the channel or conduit 23, each leaf or film as and when it is formed, like a piston, confines between it and the preceding film a certain volume of air or other elastic fluid within the conduit and carries said air or other elastic fluid toward and through the collecting chamber and, therefore, toward and through the diffuser. Of course, as this air or other elastic fluid is moved toward the diffuser, other air will pass in through inlet 22 to take its place.

The distributor, it will be noticed, embraces but a few of the total number of blades on the rotor element; that is, the

rotor element is of the partial injection type or partial influx type, as distinguished from a total injection or total influx type in which all of the blades at a time are supplied.

The number of blades on the rotor element may be varied to suit different conditions; but I have found that for a given speed of rotation of the rotor element, it is desirable to have the number of blades such that they will travel past the distributor at the rate of about 1000 per second. As each blade in passing the distributor entrains a small quantity of water delivered by the distributor, each blade will project one film or leaf of water across the conduit 23 and as the dimensions of the conduit at the point where the leaves are projected from the blades are such that the leaves or films will substantially completely fill the conduit or bridge it as a piston does a cylinder, a certain volume of air in the conduit will be cut off from the remainder of the air and moved toward the diffuser by means of the leaves or films.

As it is necessary that the films or leaves of water in moving through the conduit 23 toward and through the diffuser have a velocity sufficient to prevent the air which they entrap and carry with them from breaking through and escaping around the leaves or films, it is necessary to give to the leaves or films a speed of travel of about 120 feet per second, and this can be done by giving to the blades a speed of travel of from sixty to seventy feet per second, depending upon the angle of the blades.

In accordance with the provisions of the patent statutes, I have described the principle of operation of my invention, together with the apparatus which I now consider to represent the best embodiment thereof, but I desire to have it understood that the apparatus shown is only illustrative and that the invention can be carried out by other means.

What I claim is:

1. In an air or other elastic fluid pump, a bladed rotor element, means for delivering liquid to a number of the blades thereof less than the total number, conduit means adapted to receive and collect the liquid discharged by said rotor element and of such cross-sectional area relative to said blades that the liquid discharged by said blades bridges or fills the same as a piston does a cylinder and a diffuser in line with the outlet of said conduit means.

2. In an air or other elastic fluid pump, a collecting or combining chamber, a diffuser, a rotor element provided with blades of such size relative to the cross-sectional area of said collecting chamber that liquid discharged therefrom will substantially fill said collecting chamber as a piston fills a cylinder

and means located within the periphery of said rotor element for discharging liquid to a number of the blades thereof less than the total number.

5 3. In a fluid translating device, a stationary conduit, having an inlet adapted to communicate with a source of fluid to be translated, an outlet adapted to communicate with a diffuser and a laterally disposed opening
10 formed therein at a point intermediate the inlet and outlet, a rotatable liquid projector having an annular row of blades mounted thereon adapted to project liquid in the form of relatively thin leaves or sheets across and
15 through said conduit, a distributing nozzle for simultaneously delivering liquid to a number of said blades less than the total number, and a diffuser in line and communicating with said conduit, said conduit converging toward the outlet and having a
20 cross sectional area, adjacent to said lateral opening formed therein, such that the width thereof is substantially equal to the length of the discharge edges of the blades.

25 4. In an air or other elastic fluid pump, a chamber provided with an inlet for fluid and an outlet, means arranged so as to project liquid at a relatively high velocity in the form of films or leaves into said chamber
30 between the inlet and outlet thereof and a starting ejector associated with said device.

5. In an air or other elastic fluid pump, a chamber provided with an inlet for fluid and an outlet, means employing a partial injection rotatable liquid impeller arranged so as to project liquid at a relatively high velocity in a sub-divided state into said chamber between the inlet and outlet thereof,
35 means in line with said outlet for transforming fluid velocity into pressure and an ejector device arranged between the inlet of said means and the outlet of said chamber.
40

6. In an air or other elastic fluid pump, a chamber provided with an inlet for fluid and an outlet, means employing a partial influx rotatable liquid impeller arranged so as to project liquid at a relatively high velocity in a sub-divided state into said chamber between the inlet and outlet thereof, means
45 communicating with said outlet for transforming fluid velocity into pressure, a passage arranged so as to maintain a pressure at the inlet of said velocity transforming means substantially the same as the pressure
50 within said chamber and an ejector device communicating with said velocity transforming means.
55

7. In an air or other elastic fluid pump, a bladed rotatable impeller, stationary means
60 for delivering liquid to a portion only of the periphery thereof and a collector for the liquid projected by said impeller; the width of the collector at the point of entrance of said liquid being substantially the same as
5 the effective length of the impeller blades.

8. In an apparatus of the character described, the combination of a stationary distributing nozzle, a partial injection rotatable impeller for discharging the liquid distributed by said nozzle, and a rectilinear
70 channel or conduit means across and lengthwise of which said impeller discharges.

9. In an air or other elastic fluid pump, rotary means for forming a succession of liquid films or pistons and for causing all of
75 the films or pistons to travel as such in substantially the same straight line, and a conduit means, having a fluid inlet port and an outlet port, receiving said films or pistons at a point intermediate said ports and extending in substantially the direction of
80 travel of said films or pistons and of such cross-sectional area that the films or pistons discharged from the rotary means bridge or fill the same as a piston does a cylinder
85 throughout a portion of the length of said conduit means.

10. In an air or other elastic fluid pump, rotary means for forming a succession of fluid films or pistons and for projecting all
90 of said films or pistons as such in substantially the same straight line, and a conduit means, having an inlet and an outlet port, converging toward its outlet port and receiving said films or pistons at a point intermediate said ports, the portion of said conduit means through which said films or pistons pass extending in substantially the direction of travel of the films or pistons, and being of such cross-sectional area that each piston or
95 film fills or bridges it as a piston does a cylinder.
100

11. In an air or other elastic fluid pump, rotary means for forming a succession of liquid films or pistons and for projecting
105 all of said films or pistons as such in substantially the same straight line, a conduit means, having an inlet and an outlet port, converging toward its outlet port and receiving said films or pistons at a point intermediate said ports, the portion of said conduit means through which said films or pistons pass extending in substantially the direction of travel of the films or pistons, and being of such cross-sectional area that each
110 piston or film fills or bridges it as a piston does a cylinder, and a divergent diffuser communicating with the outlet port of said conduit means.
115

12. In an air or other elastic fluid pump, a bladed impeller, means for delivering liquid to a number of the blades less than the total number thereof, a collecting and combining chamber, having an inlet port for fluid to be pumped and an outlet port, said chamber
120 receiving the liquid discharged from said impeller at a point intermediate said ports and extending, from the point of admission of the liquid to the outlet port, in substantially the direction of travel of the liquid
125
130

discharged from the impeller, and being of such cross-sectional area relatively to the length of the blades of the impeller that the liquid discharged from the blades bridges or fills the same as a piston does a cylinder, and a diffuser in line with the outlet port of said conduit means.

13. In an air or other elastic fluid pump, a partial admission, rotatable, bladed impeller for forming a succession of liquid films or pistons and for causing all of the films or pistons to travel as such in substantially the same straight line, a collecting and combining chamber having an inlet and an outlet port and converging toward the outlet port, said chamber receiving liquid from the impeller at a point intermediate said

ports and extending, from the point of admission of the liquid to the outlet port, in substantially the direction of travel of the liquid films or pistons, and being of such cross-sectional area, relatively to the length of the blades of the impeller, that the films or pistons completely fill or bridge the same as a piston does a cylinder, and a diffuser communicating with said chamber.

In testimony whereof, I have hereunto subscribed my name this 30th day of August, 1909.

MAURICE LEBLANC.

Witnesses:

ETIENNE SOULÉ,
PIERRE LEBLANC.

Copies of this patent may be obtained for five cents each, by addressing the "Commissioner of Patents, Washington, D. C."