

(19)



(11)

**EP 2 019 177 A2**

(12)

**EUROPEAN PATENT APPLICATION**

(43) Date of publication:  
**28.01.2009 Bulletin 2009/05**

(51) Int Cl.:  
**E04G 1/14 (2006.01)**      **E04G 1/15 (2006.01)**  
**E04G 7/30 (2006.01)**

(21) Application number: **08161006.5**

(22) Date of filing: **23.07.2008**

(84) Designated Contracting States:  
**AT BE BG CH CY CZ DE DK EE ES FI FR GB GR  
HR HU IE IS IT LI LT LU LV MC MT NL NO PL PT  
RO SE SI SK TR**  
Designated Extension States:  
**AL BA MK RS**

(71) Applicant: **Lombardi, Ignazio**  
**00159 Roma (IT)**

(72) Inventor: **Lombardi, Ignazio**  
**00159 Roma (IT)**

(30) Priority: **23.07.2007 IT RM20070163 U**

(74) Representative: **Sarpi, Maurizio**  
**Studio Ferrario**  
**Via Collina, 36**  
**00187 Roma (IT)**

**(54) Removable horizontal member for supporting platforms of scaffolding for the building sector**

(57) A removable horizontal member for supporting resting surfaces of scaffolding for the building sector comprises a tubular body (TR) of appropriate length, which is provided with end fixing means designed not to interfere with the laying of the well-known metal boards

(A) for forming the treading surfaces of the scaffolding.  
Said tubular body (TR) has a length such as to be fixable horizontally to the vertical uprights of one and the same frame (T) or to the vertical uprights of two adjacent frames (T) of the scaffolding.

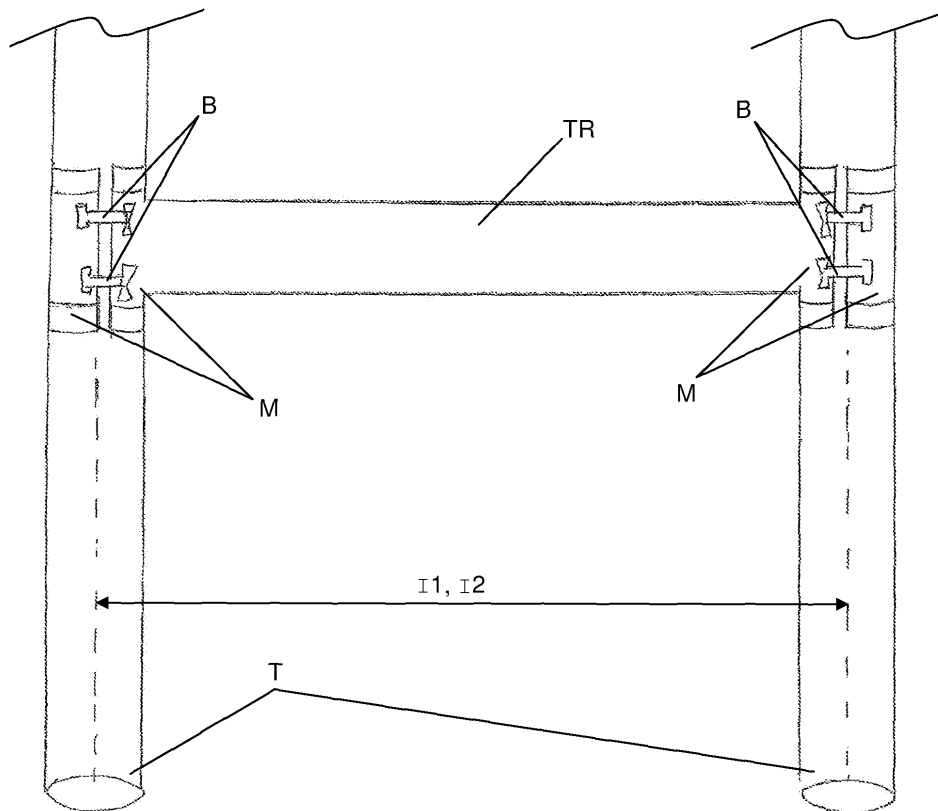

FIG. 3

**EP 2 019 177 A2**

**Description**

**[0001]** The present invention relates to the building sector, and in particular to the scaffolding that is temporarily erected up against buildings during construction and/or maintenance operations.

**[0002]** Currently known are different types of scaffolding. Amongst the most common, the following may be cited:

- the system with tubes and couplers, better known as Innocenti-tube scaffolding (from the name of the inventor Ferdinando Innocenti), which is very versatile and suitable for any type of use, but more laborious to put up; and
- the system with prefabricated frames, devised for use on facades of buildings of fairly simple shape.

**[0003]** The latter system is widely used on account of the ease and speed of assembly, and is made up of three main elements: the prefabricated frame; the braces, arranged laterally, either in a horizontal direction or in a diagonal direction, between one frame and another; and the metal boards, which form the treading surface for the workers.

**[0004]** A problem known in the sector is represented by the fact that, in order to carry out work at heights different from the pre-set ones that are determined by the difference in height between one treading surface and the immediately overlying or underlying one, it is necessary to resort to makeshift supports resting directly on the existing treading surface, to the prejudice of safety standards governing working environments.

**[0005]** A possible alternative for providing workers with an additional treading surface set at any height between the normal treading surfaces of the scaffolding itself would be that of applying to the uprights of the frames Innocenti-type tubes fixed in a known way with the corresponding clamps.

**[0006]** A first problem, in this case, is represented by the fact that the encumbrance of the clamps of the Innocenti tubes is such as not to allow proper positioning of the boards that make up the treading surface, which have a pre-set width and would interfere with the fixing bolts of the clamps themselves.

**[0007]** A second problem is represented by the fact that, using said Innocenti tubes arranged in a direction transverse to the scaffold, the boards resting thereon would be misaligned vertically with respect to the boards of the normal overlying and underlying treading surfaces installed in the usual way on the frames of the scaffold itself.

**[0008]** A third problem consists in the fact that, if the scaffolding is erected up against the facade of a building, it may be difficult or even impossible to tighten some of the bolts of the Innocenti clamps because the wrench can interfere, in its movement, with the facade itself.

**[0009]** The main purpose of the present invention is to overcome the above problems, enabling provision of at least one removable treading surface, which can be installed at any height between the treading surfaces of the currently existing scaffold of the prefabricated-frame type.

**[0010]** The above has been obtained, according to the invention, by providing a horizontal member of appropriate length, which is provided with end fixing means designed not to interfere with laying of the well-known metal boards for providing the treading surfaces of scaffolding. Said horizontal member has a length such that it can be fixed horizontally to the uprights of one and the same frame or to the uprights of two adjacent frames.

**[0011]** A better understanding of the invention will be obtained from the ensuing detailed description with reference to the attached plates of drawings, which illustrate, purely by way of non-limiting example, a preferred embodiment. In the plates of drawings:

Figure 1 is a schematic illustration of a scaffolding of a known type with prefabricated frames, during the operations of assembly and erection;

Figure 2 is a schematic illustration of the various components and accessories provided for the scaffolding of Figure 1; and

Figure 3 is a schematic illustration of the removable horizontal member according to the present invention.

**[0012]** With reference to Figures 1 and 2, which regard the known art, it may be readily noted that, although multiple accessories are provided for the scaffolding, it is not possible to provide treading surfaces at any height between a given treading surface of the scaffolding and the one immediately above or below it. In addition, a "reduced frame" is provided, which usually has a height equal to half that of the normal frame. In any case, also using this reduced frame, there are at least two limitations: one regards the fact that the height of the treading surface is pre-set, and the other regards the fact that the need for said intermediate treading surface must be envisaged during assembly of the scaffolding, and it is not possible to arrange it subsequently, i.e., after the scaffolding has been erected.

**[0013]** In addition, the possible presence of the frame at a reduced height - which cannot be dismantled - along the scaffolding constitutes an evident hindrance to the free circulation of workers on the scaffolding itself.

## EP 2 019 177 A2

Legend of Figure 2

1. Frame	2. Reduced frame
3. Vertical cross brace	4. Horizontal cross brace
5. Horizontal brace	6. Small horizontal end brace
7. End upright	8. End upright with support and coupler
9. Long end upright	10. Support with two couplers for end upright
11. Long end upright with support and coupler	12. End gate with fixed toe-board
13. Street-protection fan	14. Lower frame for restricted start
15. Upper frame for restricted start	16. Bracket
17. Strut for bracket	18. Long truss for carriage way (2 trusses/2 links)
19. Short truss for carriage way (2 trusses/1 link)	20. Link for trusses
21. Hook for scaffolding	22. Simple base plate
23-26. Adjustable base plates of various heights	27. Plane galvanized board with 6 hooks
28. Galvanized board with trapdoor (multilayer)	29. Galvanized toe-board
30. Lateral galvanized toe-board	31. Ladder for scaffolding

**[0014]** With particular reference to Figure 3, the horizontal member TR according to the invention is basically constituted by a horizontal stretch of Innocenti tube of the same diameter as the tubes making up the frames, which is provided, at its ends, with two Innocenti-type clamps M designed to be constrained to the uprights or standards of at least one frame T of the scaffolding, via purposely provided bolts B.

**[0015]** According to a first peculiar characteristic of the invention, said bolts are positioned so that, once tightened, they do not interfere with the laying of the boards A that make up the treading surface at the desired height.

**[0016]** A second peculiar characteristic of the invention lies in the fact that said bolts B of the end clamps M of the horizontal member TR are pre-arranged so as to enable the workers to tighten/loosen them while they are within the scaffolding so that the horizontal member TR that is described will be conveniently installed on/removed from the scaffolding itself without interfering with the wall of the building up against which the scaffolding is set. Said end clamps M are substantially similar to the Innocenti end couplers, commonly used for joining two tubes to one another.

**[0017]** It should be noted that, according to the invention, in order to provide an additional treading surface, which is removable and installable at the desired height, it is necessary to install at one and the same height at least two horizontal members TR set on two adjacent frames T, between the uprights of each frame, hence transverse to the scaffolding, or else two horizontal members TR set between two adjacent frames T, and hence longitudinally with respect to the scaffolding. On said two horizontal members TR, the boards A that form the treading surface at the desired height are then rested in a known way.

**[0018]** In the example illustrated, the horizontal member TR has a length corresponding to the distance l1 between the axes of the vertical uprights 5 of a standard frame T, which is 1.05 m.

**[0019]** With the same characteristics and advantages, it is also envisaged to make a horizontal member TR to be set between two adjacent frames T of the scaffolding: in this case, the horizontal member TR is set parallel to the scaffolding 10 and has a length corresponding to the distance between the axes 12 of the vertical uprights of two adjacent standard frames T, which is 1.80 m.

**[0020]** From what has been said, it appears evident that, thanks to the horizontal member TR according to the present invention, it is advantageously possible to provide treading surfaces at different heights with respect to the normal treading surfaces of the scaffolding already erected, without having to intervene on the latter.

**[0021]** In addition to this, the invention provides the maximum versatility, enabling provision of said additional treading surfaces, which can be positioned according to the specific requirements of intervention, having available substantially the entire height of the frames T between one treading surface and another.

**[0022]** Finally, yet a further advantage of the invention is represented by the fact that, given that each horizontal member TR can be installed exactly underneath the horizontal element of the frame T to which it is fixed, it enables additional treading surfaces to be provided that are exactly aligned with the existing ones either above or below the latter, thus eliminating the danger of the workers that use them from putting their foot wrong.

## Claims

- 5 1. A removable horizontal member for supporting resting surfaces of scaffolding for the building sector, **characterized in that** it comprises a tubular body (TR) of appropriate length, which is provided with end fixing means (M) designed not to interfere with laying of the well-known metal boards (A) for making up the treading surfaces of the scaffolding; said tubular body (TR) having a length such as to be fixable horizontally to the vertical uprights of one and the same frame (T) or to the vertical uprights of two adjacent frames (T).
- 10 2. The horizontal member according to the preceding claim, **characterized in that** it is constituted substantially by a horizontal stretch (TR) of Innocenti tube of the same diameter as the tubes making up the frames (T), which is provided, at its ends, with two clamps (M) substantially similar to those for fixing the Innocenti tubes, designed to be constrained to the uprights of at least one frame (T) of the scaffolding, via purposely provided bolts (B).
- 15 3. The horizontal member according to the preceding claim, **characterized in that** said bolts (B) are positioned so that, once tightened, they do not interfere with laying of the boards (A) that form the treading surface set at the desired height.
- 20 4. The horizontal member according to the preceding claim, **characterized in that** said end clamps (M) of the horizontal member (TR) are substantially similar to the Innocenti end couplers; thus obtaining that said clamps (M) can be tightened/loosened by the workers while they are within the scaffolding already erected so that the horizontal member (TR) can be conveniently installed on/removed from the scaffolding itself, without interfering with the wall of the building up against which the scaffolding is set.
- 25 5. The horizontal member according to any one of the preceding claims, **characterized in that** it has a length corresponding to the distance (I1) between the axes of the vertical uprights of a standard frame (T), which is 1.05 m; thus obtaining that said horizontal member (TR) can be set transversely to the scaffolding, i.e., between the vertical uprights of one and the same frame (T).
- 30 6. The horizontal member according to any one of Claims 1 to 4, **characterized in that** it has a length corresponding to the distance (I2) between the axes of the vertical uprights of two adjacent standard frames (T), which is 1.80 m; thus obtaining that said horizontal member (TR) can be set in a direction parallel to the scaffolding, i.e., between two adjacent frames (T) of the latter.
- 35 7. A scaffolding of the type with prefabricated frames (T), **characterized in that** it envisages at least one pair of horizontal members (TR) according to one or more of the preceding claims, on said horizontal members there being rested - in a known way - the boards (A) for providing a corresponding treading surface at any height between the treading surfaces already existing in the scaffolding; each of said horizontal members (TR) being constrained horizontally in a removable way between the vertical uprights of one and the same frame (T) or between the vertical uprights of two adjacent frames (T).
- 40 8. A removable treading surface, which can be installed at any height between the treading surfaces of the known frame-type scaffolding that has already been erected, said treading surface being **characterized in that** it is constituted by at least one board (A) resting between two horizontal members (TR) according to any one of Claims 1 to 6.
- 45
- 50
- 55

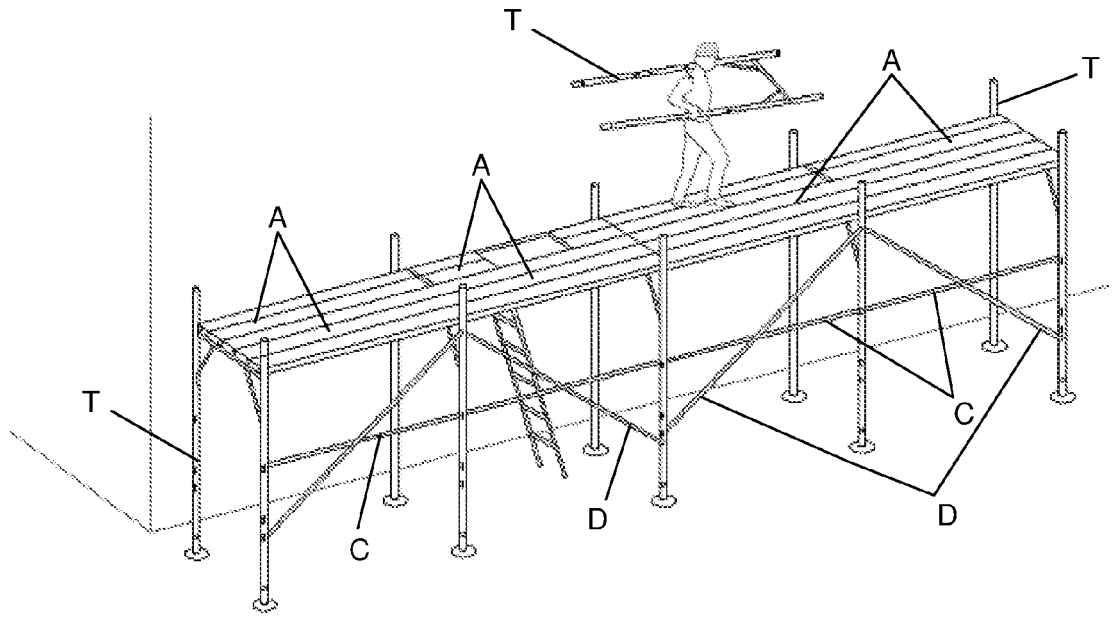

FIG. 1

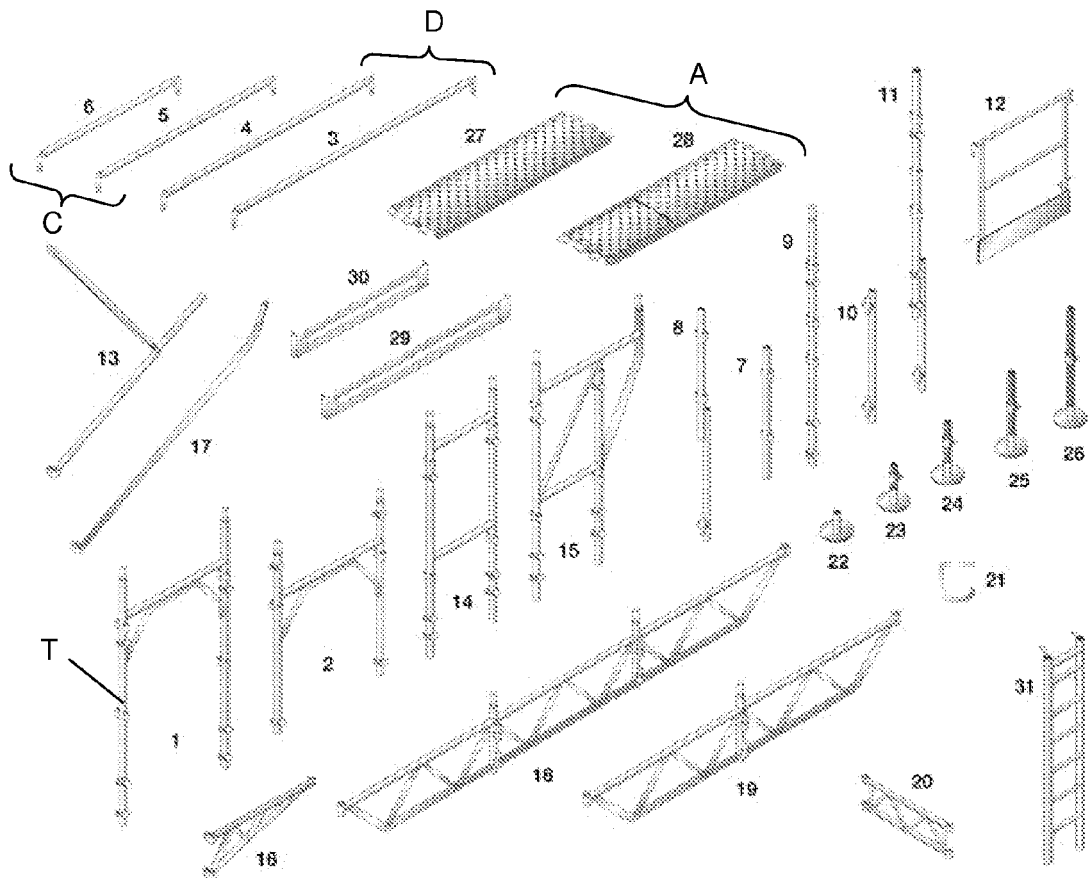

FIG. 2

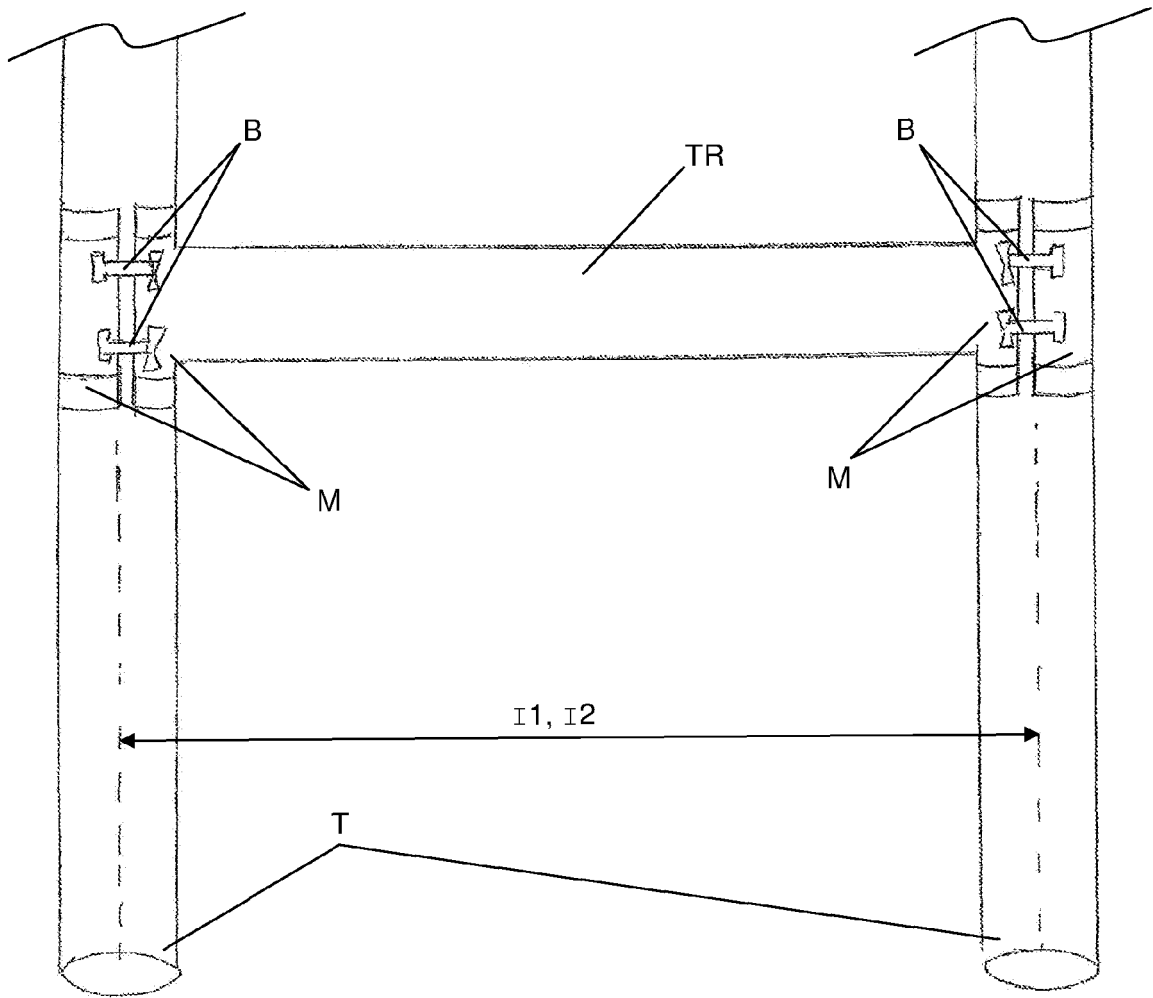

FIG. 3