

(No Model.)

2 Sheets—Sheet 1.

H. H. FEFEL.
TRIMMER FOR SEWING MACHINES.

No. 523,933.

Patented July 31, 1894.

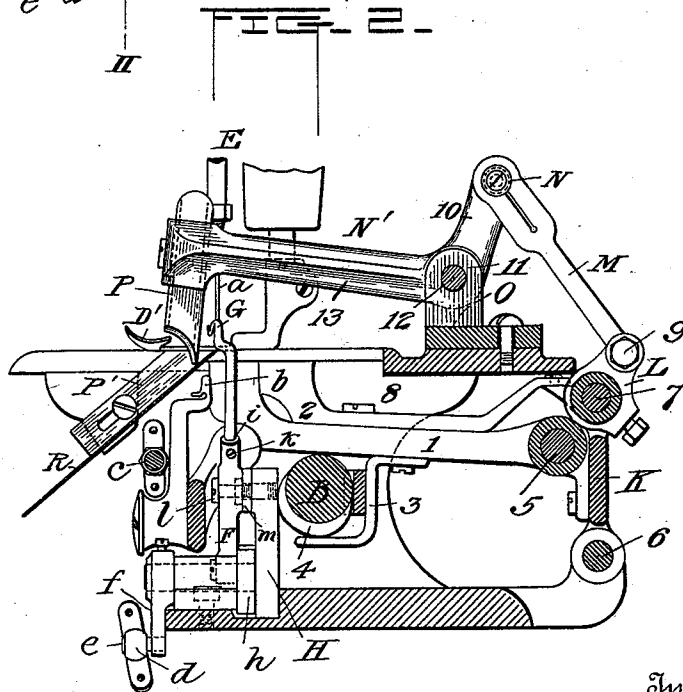
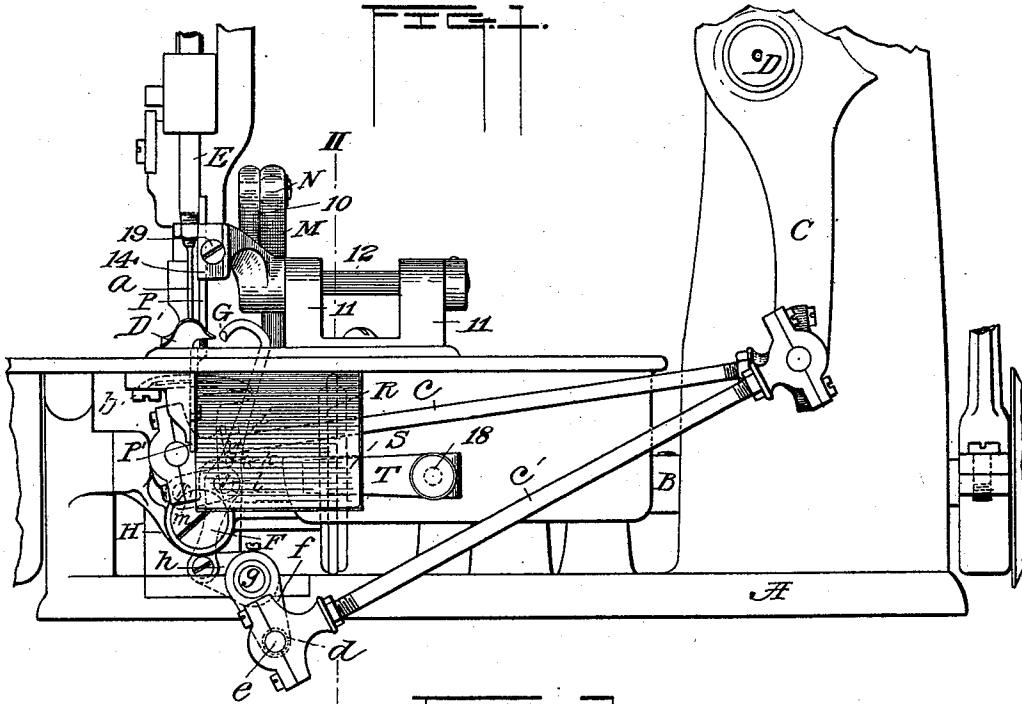

Witnesses
L. A. Connor Jr.
Gales P. Moore.

Inventor
Henry H. Fefel.
 by
Chas. S. Sturtevant
 his Attorney

(No Model.)

2 Sheets—Sheet 2.

H. H. FEFEL.
TRIMMER FOR SEWING MACHINES.

No. 523.933.

Patented July 31, 1894.

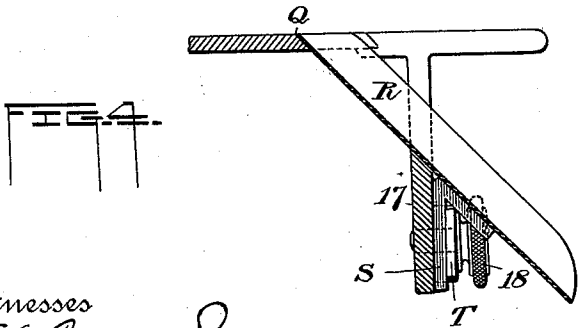
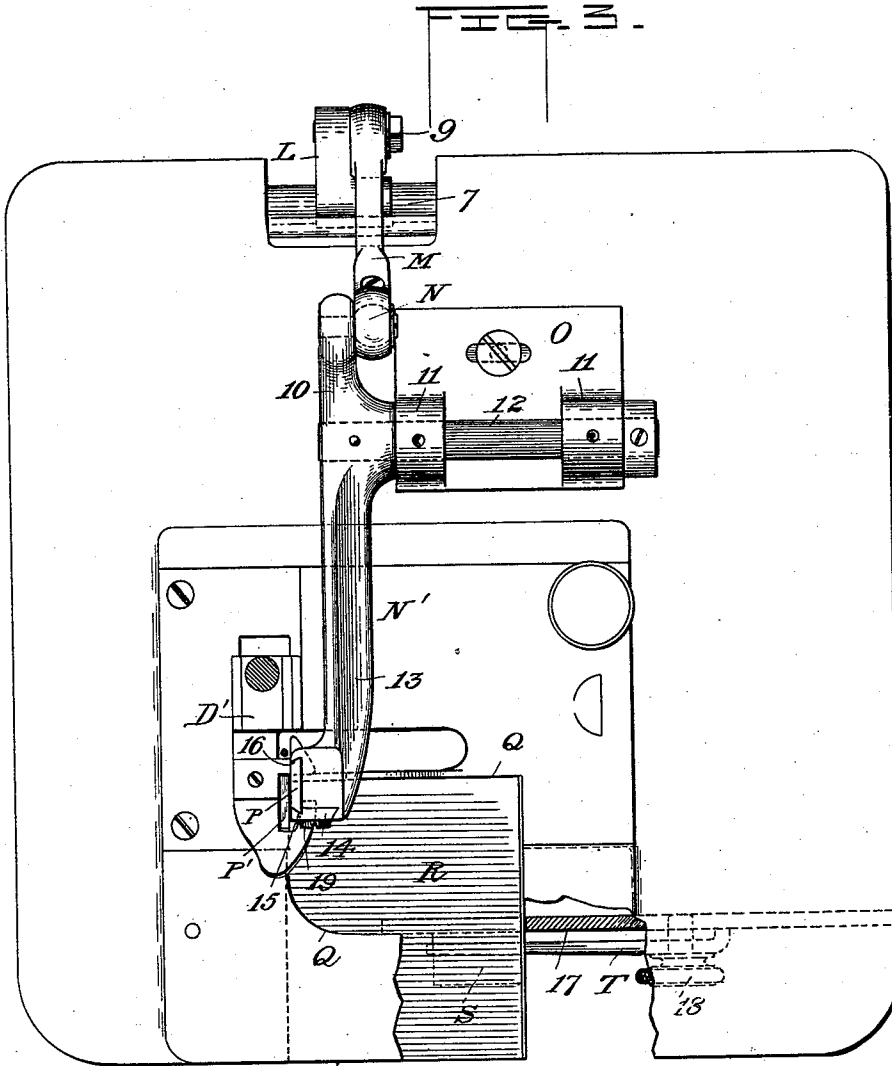

Witnesses

T. A. Connor
Gales & Moore

Inventor
Henry H. Fefel
by *Chas. S. Sturtevant*
his Attorney

UNITED STATES PATENT OFFICE.

HENRY H. FEFEL, OF NEW YORK, N. Y., ASSIGNOR TO THE UNION SPECIAL SEWING MACHINE COMPANY, OF CHICAGO, ILLINOIS.

TRIMMER FOR SEWING-MACHINES.

SPECIFICATION forming part of Letters Patent No. 523,933, dated July 31, 1894.

Application filed August 23, 1892. Serial No. 443,832. (No model.)

To all whom it may concern:

Be it known that I, HENRY H. FEFEL, a citizen of the United States, residing at New York, in the county of New York and State of New York, have invented certain new and useful Improvements in Sewing-Machines, of which the following is a description, reference being had to the accompanying drawings, and to the letters and figures of reference marked thereon.

My invention relates to an improvement in sewing machines and while in its broadest sense it is applicable to almost any character of machine, yet I propose to use it principally in connection with machines for overseaming or uniting the edges of fabrics.

In an application filed by me June 29, 1892, Serial No. 438,418, I have claimed a seam for overseaming or uniting fabrics, and in an application filed August 3, 1892, Serial No. 442,001, I have described and claimed a machine designed to make that seam. Said machine has relation especially to that class in which a spreader working from below up through the cloth plate carries a loop of thread over the edge of the fabric, where it is secured on the upper surface by the sewing needle passing through the loop.

The present invention is in certain respects an improvement upon said machine referred to, as I propose to use it principally in connection with said machine and have so illustrated it in the drawings. I wish it to be understood, however, that I am not limited to this machine, as the invention in certain features is applicable to other machines for performing the same kind of work, or to other types of machines operating on various kinds of fabric.

My invention therefore consists in various details of construction and combinations and arrangements of parts, all as hereinafter described and referred to in the appended claims.

My invention is illustrated in the accompanying drawings, in which—

Figure 1 is a side elevation of so much of a sewing machine as is necessary to a proper understanding of my invention. Fig. 2 is a sectional view on the line II—II of Fig. 1.

Fig. 3 is a plan view. Fig. 4 is a sectional view illustrating the manner of securing the angular deflecting plate to the machine.

In the drawings, A represents a portion of the frame of the machine.

B is the main shaft, and C is the downward extension of the needle arm which is pivoted to the frame of the machine at D.

E is the needle bar supporting the thread carrying, eye pointed needle *a*.

D' is the presser foot having a tongue over which the spreader lays the thread. This tongue is herein shown to be integral with the presser foot but if desired can be made removable in the ordinary way, which is not deemed necessary of illustration.

Co-operating with the needle *a* is the looper *b* actuated by means of the looper arm *c* from the extension C of the needle arm lever.

Power is communicated to the parts in the usual manner, the parts above referred to being all identical in construction with the corresponding parts in the well known Union Special Sewing Machine and do not need further explanation.

An arm *c'* similar in all respects to the looper arm *c* is connected at one end to the needle arm extension C just as is the looper arm, and at its opposite end is secured to it a split bearing in which is journaled a ball *d* in the end of a stud *e* secured upon the lower end of a crank *f* attached to the shaft *g*. A second crank *h* is attached on this shaft and carries a stud upon which is secured the lower end of the spreader support F. This spreader support may be in one piece with the spreader G but is preferably provided with a socket *i* in which the shank of the spreader is secured by a set screw *k*.

The support F is pivoted as shown at *l* to a link *m* which in turn is pivoted to an upwardly extending arm or standard H. This spreader is of well known construction and is provided with a projection adapted in the backward movement to catch the looper thread to carry it above the fabric.

It will be seen that by the manner of supporting the spreader and transmitting motion to it through the cranks *f* and *h* it has a movement from below the cloth plate par-

allel with the needle up through the plate over the edge of the fabric to a point in front of the needle.

The needle and looper being successively threaded, the looper at the time of threading being in its farthest retracted position, the needle in its lowest position and the spreader in its lowest position, the machine is started. In the forward movement of the looper it carries a loop of the under thread through the loop which has been brought down through the fabric by the needle, and at the same time the spreader ascends and catches up the thread of the looper of the machine, carrying a loop up over the edge of the fabric and spreading it so that the needle in its second descent will go through the loop formed in the thread carried up by the spreader, and at the same time the looper on the under side of the goods is in such position relative to the spreader on the upper side of the goods as to make a loop in the under thread so that when the needle comes down through the fabric in its second descent it will pass through this loop also. The spreader then drops the thread and descends to a point where it can catch the lower thread to aid in forming the next stitch. The throat plate is also provided with a tongue beneath which is a secondary tongue and between these is a space or notch into which in the upward movement of the spreader the lower thread is forced and thereby held at such an angle that the needle in its descent will invariably pass down within the loop formed by the thread, thereby preventing any dropping of stitches. This arrangement is not, however, herein fully illustrated and for a more detailed explanation reference is made to my aforesaid application of August 3, 1892.

I shall now proceed to describe the parts of the machine which constitute my present invention. The main shaft B is in such relation to the bars 1, 2, carrying the feed dogs as to give them the necessary vertical and forward and backward movements in the manner common to the Union Special machines. As herein shown the bar 1 carrying one of the feed dogs has a downwardly extending piece 3 projecting beneath the cam 4 on the main shaft, the vertical movement of the feed being effected by the cam 4. The horizontal movements of the feed are effected by the rocking frame K and the crank attachment on the forward end of the main shaft as shown in patent to Muther and Dearborn, June 3, 1884, No. 299,568, and not deemed necessary of illustration herein.

The feed bar 1 is attached at one end to the shaft 5 secured to the frame K which has rocking movement on the shaft 6 journaled on the frame of the machine. At the upper portion of the rocking frame K is a second shaft 7 to which the bar 2 carrying the forward feed dog is attached, this bar being also attached to the bar 1 as shown at 8. By this means a two

motion feed results but this forms no part of the present invention and is not essential inasmuch as any kind of feed in which a rocking frame is actuated from the main shaft is an element, is the only essential for the application of my invention.

Encircling the shaft 7 and rigidly secured thereto so as to oscillate therewith, is the crank L having a screw threaded opening in its upper end into which is screwed a pivot bolt 9. About this bolt is journaled the lower end of an arm M extending obliquely up over the cloth plate of the machine and pivotally connected at its upper end by a ball joint N with the arm 10 of the bell crank lever N' pivoted at its fulcrum to the cloth plate of the machine in any suitable manner.

As herein shown, a standard O is secured to the frame of the machine from which extend upwardly two posts 11, having bearings formed in their upper ends through which bearings a shaft 12 passes, the bell crank lever N' being pivoted on this shaft.

The long arm 13 of the bell crank lever extends transversely toward the front of the machine and carries at its outer end the trimming knife P which is herein shown as arranged to trim in advance of the stitch forming mechanism but may be located behind or to one side thereof. This knife is preferably of the form shown in Fig. 2 and co-operates with the lower blade P' removably and adjustably secured in proper position, so that together the two act as a pair of shears. As a means of securing the upper knife P in the end of the long arm 13 of the lever, I have provided the means shown in the drawings. The end of the said arm is cut away to provide for the attachment of the plate 14 having the beveled groove 15, while the side of the arm is channeled so as to leave a groove 16 corresponding to the groove 15 so that when the plate 14 is attached to the arm 13 a groove with beveled sides is provided in which the beveled edges of the knife P fit and upon tightening the screw 19, the knife is securely held in position. The presser foot and throat plate are, of course, provided with proper openings for the passage of the trimming knife. In the revolution of the main shaft the rocking frame is oscillated and through the connection described the long arm 13 of the bell crank lever is reciprocated up and down, thus performing the trimming operation.

To provide for deflecting the trimmed-off portion of the fabric to the floor or into a suitable receptacle, I provide an opening Q in the cloth plate of the machine and insert therein an angular guard plate R of sheet metal or other suitable material which has a downwardly extending bracket S fitting against the hanger 17 on the bed plate, the deflector R being held in position by the clamping plate T secured at one end to the frame by a screw 18, this plate T acting as a clamp against the inclined projection S, said clamp

being swung downwardly when it is desired to remove the guard plate.

I claim—

1. A trimming device for sewing machines and the like comprising a standard above the bed plate of the machine and secured thereto, a crank lever fulcrumed on said standard, a trimmer blade carried on one end of said lever, a crank frame, a main shaft, a feed dog carrying bar connected at one end with the crank frame and at its opposite end in connection with the main shaft whereby the crank frame is rocked, and operative connections between the crank lever and the rocking crank frame; substantially as described.

2. In a sewing machine, a main shaft provided with a cam, a rocking frame, bars secured thereto and carrying feed dogs and adapted to be engaged by said cam in the rotation of the main shaft, a crank secured to the rocking frame, a standard on the bed plate of the machine, a crank lever fulcrumed on the standard, a trimming device including a trimmer blade carried on one end of said lever, and a connecting rod between the rocking crank and the crank lever; substantially as described.

3. In a sewing machine, the combination with feed mechanism comprising a rocking frame to which the feed bars are connected, of a vertically reciprocating needle carrying an upper thread, a device carrying a separate under thread, a spreader independent of the under thread carrying device working from below up through and above the cloth plate of the machine to carry the under thread over the edges of the fabric where it is secured by the needle thread, with means for giving the spreader its desired movement, and a trimming device comprising a vertically moving trimmer blade, and operative connections between the feed rocking frame and the trimmer blade for operating the latter; substantially as described.

4. In a sewing machine, the combination with a main shaft, a feed rocking frame carried thereby, a bar carrying feed dogs attached to said rocking frame, and complementary stitch forming mechanism, of a shaft

7 secured to the upper part of said rocking frame, a crank secured to said shaft, a trimming device comprising a crank lever N', a trimmer blade carried at one end thereof, a rod connecting the opposite end of the lever with the crank, and a support to which the crank lever is pivoted; substantially as described.

5. In a sewing machine, the combination with the main shaft, a feed rocking frame oscillated thereby, a bar carrying feed dogs attached to said rocking frame, and complementary stitch forming mechanism, of a shaft 7 secured to the upper part of the rocking frame, a crank secured to said shaft, an arm or rod M pivoted at one end to the crank, a trimming device comprising a crank lever N', a trimmer blade carried at one end thereof, and a ball and socket connection between the lever N' and the rod M; substantially as described.

6. In a sewing machine, the combination with the main shaft, of a feed rocking frame driven thereby, a shaft as 5 to which one of the feed bars is attached, the shaft 7 to which the second feed bar is attached, a trimming device including a trimmer blade, and intermediate connection between the trimmer blade and the shaft 7 for operating the former; substantially as described.

7. In combination with the trimming device of a sewing machine, a cloth plate having an opening Q and a hanger 17, the angular deflecting plate R fitting within said opening and having a bracket S formed at an angle to the plate R, the rear side of the bracket S fitting against the hanger 17, a clamping plate T, a screw 18 passing through the inner end of said plate into the hanger 17, the outer part of said plate bearing against the front of the bracket S, whereby said bracket is clamped between the hanger 17 and the clamping plate T, substantially as described.

In testimony whereof I affix my signature in presence of two witnesses.

HENRY H. FEFEL.

Witnesses:

JOHN H. HOWELL,

D. B. LUCKEY.