

(19) World Intellectual Property Organization
International Bureau



(43) International Publication Date
17 July 2008 (17.07.2008)

PCT

(10) International Publication Number
WO 2008/086033 A1

(51) International Patent Classification:
B29C 67/00 (2006.01) **C04B 28/14** (2006.01)
B22F 3/105 (2006.01) **B28B 7/40** (2006.01)
B28B 7/46 (2006.01) **C04B 28/02** (2006.01)

Littleton, MA 01460 (US). **WILLIAMS, Derek, X.**
[US/US]; 42 Old Route 4, Berwick, ME 03901 (US).

(74) Agents: **US, Natasha** et al.; Goodwin Procter LLP, Exchange Place, Boston, MA 02109 (US).

(21) International Application Number:
PCT/US2008/000366

(81) Designated States (unless otherwise indicated, for every kind of national protection available): AE, AG, AL, AM, AO, AT, AU, AZ, BA, BB, BG, BH, BR, BW, BY, BZ, CA, CH, CN, CO, CR, CU, CZ, DE, DK, DM, DO, DZ, EC, EE, EG, ES, FI, GB, GD, GE, GH, GM, GT, HN, HR, HU, ID, IL, IN, IS, JP, KE, KG, KM, KN, KP, KR, KZ, LA, LC, LK, LR, LS, LT, LU, LY, MA, MD, ME, MG, MK, MN, MW, MX, MY, MZ, NA, NG, NI, NO, NZ, OM, PG, PH, PL, PT, RO, RS, RU, SC, SD, SE, SG, SK, SL, SM, SV, SY, TJ, TM, TN, TR, TT, TZ, UA, UG, US, UZ, VC, VN, ZA, ZM, ZW.

(22) International Filing Date: 10 January 2008 (10.01.2008)

(25) Filing Language: English

(26) Publication Language: English

(30) Priority Data:
60/879,703 10 January 2007 (10.01.2007) US

(71) Applicant (for all designated States except US): **Z CORPORATION** [—/US]; 32 Second Avenue, Burlington, MA 01803 (US).

(84) Designated States (unless otherwise indicated, for every kind of regional protection available): ARIPO (BW, GH, GM, KE, LS, MW, MZ, NA, SD, SL, SZ, TZ, UG, ZM, ZW), Eurasian (AM, AZ, BY, KG, KZ, MD, RU, TJ, TM), European (AT, BE, BG, CH, CY, CZ, DE, DK, EE, ES, FI, FR, GB, GR, HR, HU, IE, IS, IT, LT, LU, LV, MC, MT, NL, NO, PL, PT, RO, SE, SI, SK, TR), OAPI (BF, BJ, CF, CG, CI, CM, GA, GN, GQ, GW, ML, MR, NE, SN, TD, TG).

(72) Inventors; and

(75) Inventors/Applicants (for US only): **ALAM, Amir** [US/US]; 93-11 Broadmeadow Street, Marlborough, MA 01752 (US). **SPRAUER, Jean** [FR/US]; 34 Evergreen Street, Apt 1, Jamaica Plain, MA 02130 (US). **BREDDT, James, F.** [US/CA]; 73 Templeton Parkway, Watertown, MA 02472 (US). **CLARK, Nanette** [US/US]; 27 West Bradstreet Road, North Andover, Massachusetts 01845 (US). **FLYNN, Mary** [US/US]; 25 Tahattawan Road,

Published:
— with international search report
— before the expiration of the time limit for amending the claims and to be republished in the event of receipt of amendments

(54) Title: THREE-DIMENSIONAL PRINTING MATERIAL SYSTEM WITH IMPROVED COLOR, ARTICLE PERFORMANCE, AND EASE OF USE

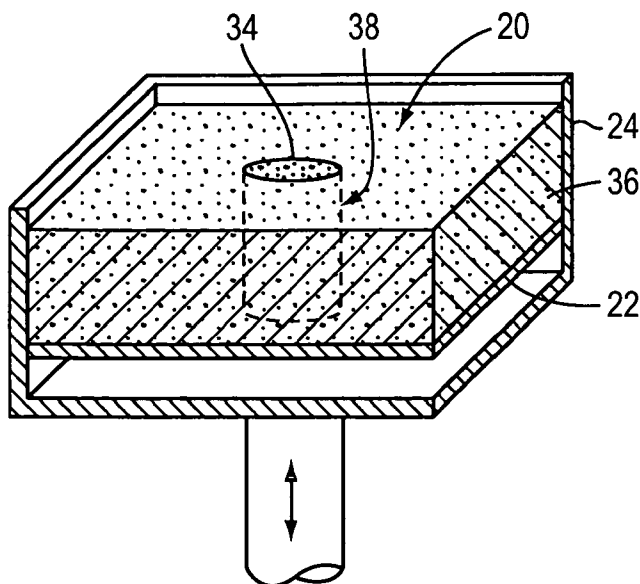

(57) Abstract: A materials system and methods are provided to enable the formation of articles by three dimensional printing. The materials system includes particulate mixtures having a whitening agent and a solid particulate additive comprising an acid, the latter adapted for modifying a cure rate of an infiltrant. The materials system also includes aqueous fluids including optical brightening agents.

WO 2008/086033 A1

THREE-DIMENSIONAL PRINTING MATERIAL SYSTEM WITH IMPROVED COLOR,
ARTICLE PERFORMANCE, AND EASE OF USE

Related Application

[0001] This application claims the benefit of and priority to U.S. Provisional Application Serial No. 60/879,703 filed January 10, 2007, the disclosure of which is hereby incorporated by reference in its entirety.

Background

5 [0002] The field of rapid prototyping involves the production of prototype articles and small quantities of functional parts, as well as structural ceramics and ceramic shell molds for metal casting, directly from computer-generated design data.

[0003] Two well-known methods for rapid prototyping include a selective laser sintering process and a liquid binder three-dimensional printing process. These techniques are similar, to
10 the extent that they both use layering techniques to build three-dimensional articles. Both methods form successive thin cross-sections of the desired article. The individual cross-sections are formed by bonding together adjacent grains of a granular, i.e., particulate, material on a generally planar surface of a bed of the granular material. Each layer is bonded to a
15 previously formed layer to form the desired three-dimensional article at the same time as the grains of each layer are bonded together. The laser-sintering and liquid binder techniques are advantageous, because they create parts directly from computer-generated design data and can produce parts having complex geometries. Moreover, three-dimensional printing can be
20 quicker and less expensive than machining of prototype parts or production of cast or molded parts by conventional "hard" or "soft" tooling techniques that can take from a few weeks to several months, depending on the complexity of the item.

[0004] An early three-dimensional printing technique, described in U.S. Patent No. 5,204,055, incorporated herein by reference in its entirety, describes the use of an ink-jet style printing head to deliver a liquid or colloidal binder material to sequentially applied layers of powdered material. The three-dimensional ink-jet printing technique or liquid binder method
25 involves applying a layer of a powdered material to a surface using a counter-roller. After the powdered material is applied to the surface, the ink-jet print head delivers a liquid binder in a predetermined pattern to the layer of powder. The binder infiltrates into gaps in the powder

- 2 -

material and hardens to bond the powder material into a solidified layer. The hardened binder also bonds each layer to the previous layer. After the first cross-sectional portion is formed, the previous steps are repeated, building successive cross-sectional portions until the final article is formed. Optionally, an adhesive can be suspended in a carrier that evaporates, leaving the hardened adhesive behind. The powdered material may be ceramic, metal, plastic or a composite material, and may also include fibers. The liquid binder material may be organic or inorganic. Typical organic binder materials used are polymeric resins or ceramic precursors, such as polycarbosilazane. Inorganic binders are used where the binder is incorporated into the final articles; silica is typically used in such an application.

5 [0005] Existing 3D printing materials offer fast, low cost methods for producing prototypes and concept models. Three-dimensional printing enables the formation of full color three-dimensional parts in one production operation. Many existing materials, however, have drawbacks, such as low handling strength, the need for the user to infiltrate the green part (i.e., as made by the machine) to increase strength, and the quality of the color created.

15 [0006] Color accuracy during three-dimensional printing affects the utility of a product. As color quality approaches that of the computer screen, designers, architects, etc., can create computer files, put the labels and shading directly on the model, and skip the steps of printing and applying labels, having the models painted, etc. One aspect of color accuracy, similar to paper printing, is the requirement to have a bright, white, neutral substrate. In three-dimensional printing (also referred to herein as "3D printing"), the models have much higher porosity than paper printing, and the substrates are not prepared in a layered fashion prior, then dried, prior to applying the inks. It is necessary to choose appropriate starting materials, i.e., powder, ink, and infiltrant, so that they combine to form a white part or article in their reacted state in order to create a high quality color part. It is not sufficient to merely include a high dose of any white pigment to achieve the brighter white. Loading a powder formula with white pigment does increase the whiteness of a printed part, but at the cost of a loss of the darker, more saturated color in the gamut.

25 [0007] Another feature of existing three-dimensional printed articles, especially those made out of plaster-based systems such as Z Corporation's zp130, is that the performance of the final, infiltrated strength of the article may vary with ambient conditions and the viscosity of the infiltrant. One common infiltrant is Z Corporation's zbond101, a cyanoacrylate-based adhesive. Similar products are made by many companies, such as Loctite. Penetration of the

30

- 3 -

infiltrant can be reduced in humid conditions where printed parts do not fully dry, or when the infiltrant has aged (therefore increased in viscosity). Reduced penetration leads to an effectively weaker prototype. The variability in performance may also be a source of frustration, as a user may be able to use his prototypes for his application during one part of the year, but not during another.

Summary of the Invention

[0008] Embodiments of the invention may include one or more of the following features. First, improvements to the powder system allow the creation of whiter three-dimensional articles by the inclusion of selected whitening agents. Second, a fluid for activating the three-dimensional printing powder includes an optical brightening agent that helps to correct the white point of the powder system, without compromising the deeper colors. Third, the addition of ingredients to inhibit the curing of infiltrants during the impregnation process allows for the creation of a stronger, more durable prototype. Finally, more careful selection of grain size allows for high green part strength, final infiltrated article strength, and improved mechanical behavior of the unreacted powder during the three-dimensional printing process. These features allow the creation of three-dimensional printed parts that are strong, have good color, have sharp feature definition, and enable a consistent user experience.

[0009] In an aspect, embodiments of the invention include a powder adapted for three-dimensional printing. The powder includes a loose, dry, and substantially free-flowing particulate mixture including a water-soluble adhesive, plaster, a plaster accelerator, a whitening agent having an L^* of at least about 90 and a C^* of up to about 5.5, and a solid particulate additive including an acid. The particulate material is adapted for use in three-dimensional printing to form an article comprised of a plurality of layers, the layers including a reaction product of the particulate material and an aqueous fluid that contacts the particulate material during three-dimensional printing. The acid has a water solubility selected from a range of about 0 – 20 g/100 mL of water, a pK_a selected from a range about 1 to about 4, and a K_{ow} selected from a range of -about 0.4 to about 1, and is adapted for modifying a cure rate of an infiltrant to facilitate penetration of the infiltrant into the article. The particulate mixture is substantially free of plaster retarders.

- 4 -

[0010] One or more of the following features may be included. The substantially dry particulate mixture may have a Bredt parameter of at least about 0.10. An internal angle of friction of the particulate material may have a value selected from a range of 40° to 70°. The particulate mixture may include about 0.01% to about 5% by weight of the whitening agent. A refractive index of the whitening agent may be at least about 1.9. The whitening agent may have a solubility in an aqueous solution of 5 wt% glycerol of at least about 5 mg/liter. The whitening agent may include a second water-soluble adhesive and/or may be a high whiteness starch or a high whiteness starch derivative. The whitening agent may be insoluble in an aqueous solution of 5 wt% glycerol. The whitening agent may include or consist essentially or zinc oxide, titanium dioxide, hollow glass spheres, limestone, a clay, and combinations thereof.

[0011] The water-soluble adhesive may include or consist essentially of polyvinyl alcohol. The pKa may be about 3 and the K_{ow} may be selected from a range of about -0.5 to about 0.5. The particulate mixture may include about 0.01% to about 5% by weight of the solid particulate additive. The solid particulate additive may include or consist essentially of fumaric acid, tartaric acid, gluconic acids, adipic acid, glucono-delta-lactone (GdL), ethylenediaminetetraacetic acid, succinic acid, a phenolic compound, and combinations thereof.

[0012] The plaster may include or consist essentially of plaster of paris, sulphate of lime, hydrated calcium sulphate, dental plaster, $CaSO_4 \cdot \frac{1}{2}H_2O$, $CaSO_4 \cdot 2H_2O$, and combinations thereof. The plaster accelerator may include or consist essentially of hydrated gypsum, potassium sulfate, potassium aluminum sulfate, and combinations thereof. The solid particulate additive may not be a catalyst affecting a rate of a reaction between the plaster and the aqueous fluid.

[0013] In another aspect, embodiments of the invention include an aqueous fluid for activating water soluble components of a three-dimensional printing powder. The aqueous fluid includes water, a humectant, a surfactant, a preservative, and about 0.05 – about 5 wt% of an optical brightening agent. The fluid is substantially clear, has a viscosity selected from a range of 1-1.35 cps, a surface tension selected from a range of 30-36 dynes/cm, and a pH selected from a range of 4.9 to 10.3

[0014] The optical brightening agent may include a fluorescent brightener based on stilbene chemistry or distyrylbiphenyl.

- 5 -

[0015] In still another aspect, embodiments of the invention include a kit. The kit includes a powder adapted for three-dimensional printing and an aqueous fluid for activating water soluble components of the powder. In particular, the powder includes a loose, dry, and substantially free-flowing particulate mixture including a water-soluble adhesive, plaster, a plaster accelerator, a whitening agent having an L^* of at least about 90 and a C^* of up to about 5.5, and a solid particulate additive including an acid. The aqueous fluid includes water, a humectant, a surfactant, a preservative, and about 0.05 – about 5 wt% of an optical brightening agent. The particulate material is adapted for use in three-dimensional printing to form an article comprised of a plurality of layers, the layers including a reaction product of the particulate material and the aqueous fluid that contacts the particulate material during three-dimensional printing. The acid has a water solubility selected from a range of about 0 – 20 g/100 mL of water, a pK_a selected from a range about 1 to about 4, and a K_{ow} selected from a range of -about 0.4 to about 1, and is adapted for modifying a cure rate of an infiltrant to facilitate penetration of the infiltrant into the article. The particulate mixture is substantially free of plaster retarders. The aqueous fluid is substantially clear, has a viscosity selected from a range of 1-1.35 cps, a surface tension selected from a range of 30-36 dynes/cm, and a pH selected from a range 4.9 to 10.3.

[0016] In another aspect, embodiments of the invention include a method for forming an article by three-dimensional printing. The method includes providing a loose, dry, and substantially free-flowing particulate mixture including a plurality of adjacent particles, the particulate mixture comprising a water-soluble adhesive, plaster, a plaster accelerator, a whitening agent and a solid particulate additive comprising an acid. An aqueous fluid is applied to at least some of the plurality of particles in an amount sufficient to bond those particles together to define at least a portion of the article. The aqueous fluid includes water, a humectant, a surfactant, a preservative, and an optical brightening agent. The defined portion of the article solidifies without mechanical agitation and without supplemental electromagnetic radiation.

[0017] One or more of the following features may be included. The article formed by the method may develop a strength of at least 1 MPa within about one hour of being formed. The article may be infiltrated with a cyanoacrylate adhesive, and may develop the final ultimate infiltrated strength within one hour of infiltration.

[0018] In another aspect, embodiments of the invention include an essentially solid article manufactured by a three-dimensional printing process. The essentially solid article includes a product of the reaction of a mixture including (i) a particulate material including a water-soluble adhesive, a partially soluble filler, an accelerator, an additive having a pKa selected
5 from a range of about 1 to about 4, and a K_{ow} selected from a range of about -0.4 to about 1 and a whitening agent, and (ii) an aqueous fluid including water, a humectant, a rheology modifier, a surfactant, a preservative, and an optical brightening agent. The particulate material is reacted with at least a portion of the aqueous fluid to form the essentially solid article including a plurality of essentially evenly distributed layers of the reaction product.

10 [0019] The article may include a cyanoacrylate-based adhesive infiltrant and have a final ultimate strength greater than 15 MPa.

[0020] In an aspect, embodiments of the invention include a powder adapted for three-dimensional printing. The powder includes a substantially dry, free-flowing particulate mixture including a water-soluble adhesive, a partially soluble filler, an accelerator, and a whitening
15 agent having an L^* of at least about 90 and a C^* of up to about 5.5. The particulate material is suitable for use in three-dimensional printing to form an article formed of a plurality of layers, the layers including a reaction product of the particulate material and an aqueous fluid that contacts the particulate material during three-dimensional printing.

[0021] One or more of the following features may be included. The substantially dry
20 particulate mixture may have a Bredt parameter of at least about 0.10. An internal angle of friction of the particulate mixture may have a value selected from a range of 40° to 70°. The particulate mixture may include about 0.01% to about 5% by weight of the whitening agent. A refractive index of the whitening agent may be at least about 1.9. The whitening agent may have a solubility in an aqueous solution of 5 wt% glycerol of at least about 5 mg/liter. The
25 whitening agent may include a salt, e.g., potassium sulfate and/or potassium aluminum sulfate. The whitening agent may include a second water-soluble adhesive. The whitening agent may be a high whiteness starch or a high whiteness starch derivative. The whitening agent may be insoluble in an aqueous solution of 5 wt% glycerol. The whitening agent may include, e.g., zinc oxide, titanium dioxide (TiO_2), hollow glass spheres, limestone, a clay, and/or
30 combinations thereof. The water-soluble adhesive may include polyvinyl alcohol. The partially soluble filler may include plaster. The accelerator comprises a plaster accelerator.

- 7 -

[0022] In another aspect, embodiments of the invention include a powder adapted for three-dimensional printing. The powder includes a substantially dry, free-flowing particulate mixture including a water-soluble adhesive, a partially soluble filler, an accelerator, and a solid particulate additive comprising an acid. The particulate material is suitable for use in three-dimensional printing to form an article comprised of a plurality of layers, the layers including a reaction product of the particulate material and an aqueous fluid that contacts the particulate material during three-dimensional printing. Also, the additive has a water solubility from about 0 – 20 g/100 mL of water, a pKa of between about 1 and about 4, and a K_{ow} selected from a range of about 0.4 to about 1, and is suitable for modifying a cure rate of an infiltrant to facilitate penetration of the infiltrant into the article.

[0023] One or more of the following features may be included. The pKa of the additive may be about 3 and its K_{ow} is selected from a range of about -0.5 to about 0.5. The particulate mixture may include about 0.01% to about 5% by weight of the additive. The additive may be, e.g., fumaric acid, tartaric acid, fatty acids, gluconic acids, adipic acid, glucono-delta-lactone (GdL), ethylenediaminetetraacetic acid, succinic acid, a phenolic compound, and/or combinations thereof. The water-soluble adhesive may include polyvinyl alcohol and the partially soluble filler may include a plaster. The accelerator may include a plaster accelerator. The plaster may be, for example, plaster of paris, sulphate of lime, hydrated calcium sulphate, dental plaster, $CaSO_4 \cdot \frac{1}{2}H_2O$, $CaSO_4 \cdot 2H_2O$, and/or combinations thereof. The plaster accelerator may be, e.g., hydrated gypsum, potassium sulfate, potassium aluminum sulfate, and/or combinations thereof. The additive may not be a catalyst affecting a rate of a reaction between the plaster and water. The powder may also include a whitening agent.

[0024] In yet another aspect, embodiments of the invention may include an aqueous fluid for activating water soluble components of a three-dimensional printing powder. The aqueous fluid may include water, a humectant, a preservative, and an optical brightening agent.

[0025] One or more of the following features may be included. The aqueous fluid may be substantially clear. The optical brightening agent may include a fluorescent brightener based on stilbene chemistry. The optical brightening agent may be distyrylbiphenyl. The aqueous fluid may include from about 0.05 – about 5 wt% of the optical brightening agent.

[0026] In still another aspect, embodiments of the invention include a kit. The kit includes a powder adapted for three-dimensional printing. The powder includes a substantially dry, free-flowing particulate mixture that includes a water-soluble adhesive, a partially soluble filler, an

accelerator, and a whitening agent having an L^* of at least 90 and a C^* of up to 5.5. The kit also includes an aqueous fluid for activating water soluble components of a three-dimensional printing powder. The aqueous fluid includes water, a humectant, a preservative, and an optical brightening agent. The particulate material is suitable for use in three-dimensional printing to form an article comprising a plurality of layers, the layers including a reaction product of the particulate material and the aqueous fluid that contacts the particulate material during three-dimensional printing.

5 [0027] One or more of the following features may be included. The kit may include a combination of binders comprising cyan, magenta, and yellow binders. The particulate material may also include a solid particulate additive including an acid.

10 [0028] In another aspect, embodiments of the invention includes a kit. The kit includes a powder adapted for three-dimensional printing. The powder includes a substantially dry, free-flowing particulate mixture including a water-soluble adhesive, a partially soluble filler, an accelerator, and a solid particulate additive comprising an acid. The kit also includes an aqueous fluid for activating water soluble components of a three-dimensional printing powder. 15 The aqueous fluid includes water, a humectant, a preservative, and an optical brightening agent. The particulate material is suitable for use in three-dimensional printing to form an article comprised of a plurality of layers, the layers including a reaction product of the particulate material and an aqueous fluid that contacts the particulate material during three-dimensional printing. The additive has a pK_a of between about 1 and about 4, and a K_{ow} selected from a range of about -0.4 to about 1, and is suitable for modifying a cure rate of an infiltrant to facilitate penetration of the infiltrant into the article. 20

[0029] The kit may include a combination of binders, including cyan, magenta, and yellow binders.

25 [0030] In another aspect, embodiments of the invention include a method for forming an article by three-dimensional printing. The method includes providing a substantially dry, free-flowing particulate material comprising a plurality of adjacent particles, the particulate material comprising a water soluble adhesive, a partially soluble filler, an accelerator, and a whitening agent. A fluid binder is applied to at least some of the plurality of particles in an amount sufficient to bond those particles together to define at least a portion of the article. The fluid binder includes water, a humectant, a rheology modifier, a surfactant, a preservative, and an optical brightening agent. 30

[0031] One or more of the following features may be included. The bonding of the article may be substantially free of mechanical agitation. The article formed by the method develops a strength of at least 1 MPa within about one hour of being formed.

5 [0032] In still another aspect, embodiments of the invention include a method for forming an article by three-dimensional printing. The method includes providing a substantially dry, free-flowing particulate material comprising a plurality of adjacent particles, the particulate material including a water soluble adhesive, a partially soluble filler, an accelerator, and an additive for controlling a curing rate of an infiltrant. A fluid binder is applied to at least some of the plurality of particles in an amount sufficient to bond those particles together to define at least a
10 portion of the article. The fluid binder includes water, a humectant, a rheology modifier, a surfactant, a preservative, and an optical brightening agent.

[0033] The particulate material may also include a whitening agent.

[0034] In still another aspect, embodiments of the invention include an essentially solid article manufactured by a three-dimensional printing process. The essentially solid article
15 includes a product of the reaction of a mixture including (i) a particulate material including a water-soluble adhesive, a partially soluble filler, an accelerator, and a whitening agent, and (ii) an aqueous fluid including water, a humectant, a preservative, and an optical brightening agent. The particulate material is reacted with at least a portion of the aqueous fluid to form the essentially solid article including a plurality of essentially evenly distributed layers of the
20 reaction product.

[0035] The whitening agent may be insoluble in an aqueous solution of 5 wt% glycerol, and may be present in the article as a passive filler.

[0036] In another aspect, embodiments of the invention include an essentially solid article manufactured by a three-dimensional printing process. The essentially solid article is a product
25 of the reaction of a mixture including (i) a particulate material including a water-soluble adhesive, a partially soluble filler, an accelerator, and an additive having a pKa selected from a range of about 1 to about 4, and a K_{ow} selected from a range of about -0.4 to about 1, and (ii) an aqueous fluid including water, a humectant, a preservative, and an optical brightening agent. The particulate material is reacted with at least a portion of the aqueous fluid to form the
30 essentially solid article including a plurality of essentially evenly distributed layers of the reaction product.

[0037] In still another aspect, embodiments of the invention include an essentially solid article manufactured by a three-dimensional printing process. The essentially solid article includes a product of a reaction of a mixture of (i) a particulate material including an additive to control a rate of cure of a cyanoacrylate adhesive, and (ii) an aqueous fluid including water, a humectant, a preservative, and an optical brightening agent. The particulate material is reacted with at least a portion of the aqueous fluid to form the essentially solid article including a plurality of essentially evenly distributed layers of the reaction product.

Brief Description of the Figures

[0038] The following drawings are not necessarily to scale, emphasis instead being placed generally upon illustrating the principles of the invention. The foregoing and other features and advantages of the present invention, as well as the invention itself, will be more fully understood from the following description of exemplary and preferred embodiments, when read together with the accompanying drawings, in which:

[0039] Figure 1 is a schematic view of a first layer of a mixture of particulate material of an embodiment of the invention deposited onto a downwardly movable surface of a container on which an article is to be built, before any fluid has been delivered;

Figure 2 is a schematic view of an ink-jet nozzle delivering a fluid to a portion of the layer of particulate material of Figure 1 in a predetermined pattern;

Figure 3 is a schematic view of a final article of an embodiment of the invention enclosed in the container, the article made by a series of steps illustrated in Figure 2 and still immersed in the loose unactivated particles;

Figure 4 is a schematic view of the final article of Figure 3;

Figure 5 is a graph illustrating brightness L^* and chroma C^* of several powders pressed into dry pellets.

Figure 6 is a diagram illustrating three stages of the anionic polymerization of a cyanoacrylate;

Figure 7 is a graph illustrating the correlation of surface finish defects caused by powder caking in crevices with acid solubility;

Figure 8 is a graph illustrating the relationship between pKa and an optimum amount of an acid that needs to be used to produce an article with a preferred combination of green part curing, appearance, accuracy, final infiltrated strength, and cure time;

Figure 9 is a three-dimensional plot of parameters used to select acid components for use as inhibitors of cyanoacrylate in a plaster based three-dimensional printing media;

Figure 10 is a graph illustrating the impact of acidifer level on the final article strength and infiltrant curing rate in a series of formulations;

5 Figure 11 is a graph illustrating the operating principle of optical brightening;

Figure 12 is a graph illustrating percentage of reflectance of light from the UV region of samples of a plaster based article treated with a fluorescent brightener as a function of wavelength and brightener concentration;

10 Figure 13 is a graph illustrating the migration of a white point from yellow towards purple as the concentration of a fluorescent brightener is increased in a plaster-containing article;

Figure 14 is a graph illustrating reduction of chroma C^* by fluorescence with little to no impact on the actual brightness of the article;

Figure 15 is a schematic illustration of a circulating spreader bead;

15 Figures 16 and 17 are graphs illustrating the forces acting on a particle during three-dimensional printing;

Figure 18a is a CAD drawing of the article portion printed in Figures 19b and 19c;

Figures 18b and 18c are laser profilometer images comparing the effect of particulate materials with high internal angle of friction on finished article properties;

20 Figure 19a is a CAD drawing of the article portion printed in Figures 20b and 20c; and

Figure 19b and 19c are laser profilometer images comparing the effect of particulate material with low internal angle of friction on finished article properties.

Detailed Description

Three-Dimensional Printing

25 [0040] Referring to Figure 1, in accordance with a printing method using the materials system of the present invention, a layer or film of a particulate material 20, i.e., a powder, is applied to a linearly movable surface 22 of a container 24. The layer or film of particulate material 20 may be formed in any suitable manner, for example using a counter-roller. The particulate material 20 applied to the surface may include a water-soluble adhesive, an
30 accelerator, and a whitening agent having an L^* of at least 90, and a C^* of up to 5.5.

Alternatively, the particulate material 20 may include a water-soluble adhesive, an accelerator,

- 12 -

and a solid particulate additive comprising an acid. The particulate material 20 may also include an additional adhesive, a filler material, a processing aid material, an absorbent filler, and/or a fibrous material.

5 [0041] Referring to Figure 2, an ink-jet style nozzle 28 delivers an activating fluid 26 to at least a portion 30 of the layer or film of the particulate mixture 20 in a two-dimensional pattern. According to the printing method, the fluid 26 is delivered to the layer or film of particulate material 20 in any predetermined two-dimensional pattern (circular, in the figures, for purposes of illustration only), using any convenient mechanism, such as a drop-on-demand (DOD) print head driven by software in accordance with article model data from a computer-assisted-design
10 (CAD) system.

[0042] The first portion 30 of the particulate mixture is activated by the fluid 26, causing the activated particles to adhere together to form a conglomerate of the particulate material 20 (powder) and fluid 26. The conglomerate defines an essentially solid circular layer that becomes a cross-sectional portion of an intermediate article 38 (see, e.g., Figures 3 and 4). As
15 used herein, "activates" is meant to define a change in state from essentially inert to adhesive. This definition encompasses the activation of the adhesive particulate material to bond the filler particulate material. When the fluid initially comes into contact with the particulate mixture, it immediately flows outwardly (on a microscopic scale) from the point of impact by capillary suction, dissolving the adhesive within a relatively short time period, such as the first few
20 seconds. A typical droplet of activating fluid has a volume of about 40 picoliters (pl), and spreads to a diameter of about 100 μm after coming into contact with the particulate mixture. As the solvent dissolves the adhesive, the fluid viscosity increases dramatically, arresting further migration of the fluid from the initial point of impact. Within a few minutes, the fluid with adhesive dissolved therein infiltrates the less soluble and slightly porous particles, forming
25 adhesive bonds between the filler particulate material as well as between the additional fillers, absorbent fillers, and/or fibers which may be present. The activating fluid is capable of bonding together an amount of the particulate mixture that is several times the mass of a droplet of the fluid. As volatile components of the fluid evaporate, the adhesive bonds harden, joining the adjacent particulates into a rigid structure, which becomes a cross-sectional portion of the
30 final article 40.

[0043] Any unactivated particulate mixture 32 that was not exposed to the fluid remains loose, dry and free-flowing on the movable surface 22. The unactivated particulate mixture is typically left in place until formation of the intermediate article 38 is complete. Leaving the unactivated, loose and dry particulate mixture in place ensures that the intermediate article 38 is fully supported during processing, allowing features such as overhangs, undercuts, and cavities to be defined and formed without the need to use supplemental support structures. After formation of the first cross-sectional portion of the intermediate article 38, the movable surface 22 is indexed downwardly, in this embodiment, and the process is repeated.

[0044] Using, for example, a counter-rolling mechanism, a second film or layer of the particulate mixture is then applied over the first layer, covering both the rigid first cross-sectional portion, and any proximate loose particulate mixture. A second application of fluid follows in the manner described above, dissolving the adhesive and forming adhesive bonds between at least a portion of the previous cross-sectional formed portion, the filler particulate material, and, optionally, additional filler, absorbent fillers, and fibers of the second layer, and hardening to form a second rigid cross-sectional portion added to the first rigid cross-sectional portion of the final article. The movable surface 22 is again indexed downward.

[0045] The previous steps of applying a layer of particulate mixture, including the adhesive, applying the activating fluid, and indexing the movable surface 22 downward are repeated until the intermediate article 38 is completed. Referring to Figure 3, the intermediate article 38 may be any shape, such as cylindrical. At the end of the process, only a top surface 34 of the intermediate article 38 is visible in the container 24. The intermediate article 38 is typically completely immersed in a surrounding bed 36 of unactivated particulate material.

Alternatively, an article could be formed in layers upward from an immovable platform, by successively depositing, smoothing, and printing a series of such layers.

[0046] Referring to Figure 4, the unactivated particulate material may be removed from the intermediate article 38 by pressurized air flow or a vacuum. After removal of the unactivated particulate material from the intermediate article 38, a post-processing treatment may be performed, such as cleaning, drying, infiltration with stabilizing materials, painting, etc. to define a final article 40, having the same shape as intermediate article 38, but with additional desired characteristics, such as a stiffness, strength, and flexibility. The final article 40 may be essentially solid, including a plurality of essentially evenly distributed layers of a reaction

product between a particulate mixture and an aqueous fluid. Suitable particulate mixtures and aqueous fluids are described in detail below.

[0047] Additionally, the article may be infiltrated with a cyanoacrylate-based adhesive, and the article may develop its final ultimate infiltrated strength within one hour of infiltration.

5 Articles infiltrated with a cyanoacrylate-based adhesive infiltrant that develop a final ultimate strength greater than 15 MPa may have a wider range of utility than articles with lower strength, or those that take longer to develop their ultimate strength.

Particulate material

10 [0048] In a preferred embodiment, a particulate material, i.e., a substantially dry particulate material, includes:

water soluble adhesive	3 - 20 wt%;
plaster	50 - 95 wt%
whitening agent	0.01 - 5 wt%
15 plaster accelerator(s)	0 - 5 wt%
solid particulate additive including an acid	0.01 - 5 wt%

Other dry particulate material components may include, for example:

processing aids	0.01-2.0 wt%
-----------------	--------------

The particulate materials and fluids described herein are adapted for producing a solid three-
 20 dimensional article by three-dimensional printing. Preferably, the formulation sets relatively quickly, such that the printed article can be handled in, e.g., minutes after the completion of the article-making process. Accordingly, although a balance of accelerators and retarders is often used in the plaster industry to create a delayed setting time, e.g., for spackling compounds, the use of retarders is preferably avoided for 3D printing. In some embodiments, the particulate
 25 mixture is substantially free of plaster retarders.

[0049] A preferred particle size of the components of the particulate material, i.e., average particle diameter, ranges from 10 micrometers (μm) to 125 μm .

[0050] The plaster (e.g., plaster of paris, sulphate of lime, hydrated calcium sulphate, dental plaster, $\text{CaSO}_4 \cdot \frac{1}{2}\text{H}_2\text{O}$, $\text{CaSO}_4 \cdot 2\text{H}_2\text{O}$, and combinations thereof) typically forms the largest
 30 portion of the article structure, providing dimensional stability and adhesion for strength of an article formed from the particulate material. Suitable plaster particulates for use with embodiments of the invention have a particle size distribution ranging from greater than 20 μm

to less than 125 μm . Preferably, the plaster is white and clean, such as, for example, the Hydrocal products produced by US Gypsum.

[0051] Plaster is frequently called “plaster of paris,” a name derived from the earths of Paris and its surrounding regions, which contain an abundance of the mineral gypsum, from which
 5 plaster of paris is manufactured. Plaster is also referred to by many other names, including, but not limited to, sulphate of lime, semihydrate of calcium sulfate, casting plaster, gypsum plaster, hydrated sulphate of lime, hydrated calcium sulphate, and dental plaster, as well as a variety of trade names. The term “plaster,” as used herein, is meant to define any variety of material including a substantial amount of $\text{CaSO}_4 \cdot \frac{1}{2}\text{H}_2\text{O}$ that is in powder form prior to the application
 10 of an aqueous fluid. The terms “hydrated plaster” and “set plaster” are used interchangeably herein, and are meant to include any variety of plaster that includes a substantial amount of $\text{CaSO}_4 \cdot 2\text{H}_2\text{O}$ after setting, or rehydration. Many varieties of plaster are commercially available, varying, for example, in structural strength, the time required for setting, and in volume changes that occur during the setting. Typically, commercially available plasters
 15 include other ingredients such as, but not limited to, silica, powder limestone, starch, Terra Alba, and lime. Examples of commercially available plaster materials that may be suitable for the present invention include, but are not limited to, white hydrocal cement, durabond 90, and drystone (each available from U.S. Gypsum, located in Chicago, IL), as well as most brands of casting plaster, molding plaster, and spackling compound.

[0052] When calcined at about 350°F, gypsum loses a substantial amount of its water of crystallization, and is thereby transformed into plaster. The dehydration, or “calcination” of gypsum, proceeds according to reaction (1) below:

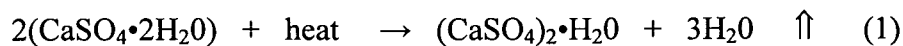

[0053] Conventional plaster processing generally involves vigorously and thoroughly mixing
 25 plaster and water to form a slurry that is saturated with water and poured into a mold to “set up,” which typically takes about 30 minutes. After the plaster is mixed with the water, small quantities of the plaster crystallize and interlock together, cementing together the remaining insoluble particles. The interlocking of crystals is responsible for a great deal of the eventual physical strength of the set plaster. Conventionally, during the period in which the plaster sets
 30 up, any physical disturbance to the setting plaster should be minimized, or the plaster may not achieve its potential maximum strength, because the minute crystals of gypsum will not completely interlock. When mixed with sufficient water, plaster recovers the $1\frac{1}{2}$ parts of water

it possessed prior to calcination of the gypsum, and sets to a solid material of substantially the same composition as gypsum. When properly calcined, plaster is fairly insoluble in cold water and only slightly soluble in warm water. For example, at room temperature, about one part of plaster is soluble in about 400 parts of water. The rehydration, or re-crystallization of plaster, after it has been mixed with water, is referred to as “setting,” and proceeds according to the following equation (2):

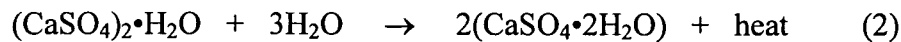

[0054] In embodiments that include a plaster-containing particulate material, the plaster chemistry is preferably considered when selecting any additive, both for the powder and the liquid binder. Many starches and water soluble polymers hold onto water tightly, thereby slowing the rate at which plaster articles dry and reducing the handling strength of the articles at early timepoints. Strongly ionic materials, i.e., chelating agents, for example some phosphates such as sodium tripolyphosphate, may interfere with the plaster hydration reaction by chelating the calcium ions or competing for the sulfate ion, which may reduce the driving force toward calcium sulfate dihydrate, thereby retarding the set of the printed layers and allowing distortion to happen during printing during the swelling and contraction of the water soluble adhesives.

[0055] To determine the strength performance of a particular particulate material, it is generally preferable to print a standard test specimen on a 3D printer, for example a zprinter310 plus, made by Z Corporation of Burlington, MA. A useful specimen for evaluating the strength of an article formed by this method is a small bar, with dimensions of roughly 5 millimeter (mm) x 5.5 mm x 50 mm. Such bars may be printed, allowed to sit for approximately one hour in the machine after printing, and then broken on a 3-point bend testing machine. The same bars may be dried in an oven at 100°F for up to 24 hours to determine the final strength that may be expected from a 3D printed article, prior to infiltration.

[0056] Additionally, the surface of an article may be examined for any excess caking of powder, the measure of which has been called depowderability. Depowderability may be measured by printing an article with a series of cylindrical holes of decreasing internal diameter. A depowderability score of 1 means that a hole with a diameter of approximately 6 mm can be cleared by blowing on the article with a compressed air supply, and a score of 10 would correlate to a hole of approximately 2 mm in diameter that can be successfully cleared with compressed air under the same conditions. An article made with a mixture resulting in a

low depowderability score, i.e., is difficult to depowder, typically tends to have superfluous material adhering to its outside surface. This superfluous material may cause inaccurate geometry, i.e., articles may be formed larger than specified. Articles that score very highly for depowderability, e.g., >10, may still exhibit a haze of white particles that is detrimental to the color accuracy of a prototype article. Haze may be assessed by eye, or measured with a device such as the Greytag MacBeth iOne handheld color spectrophotometer. Articles where the intended color appears “washed out” due to haze are generally not desirable.

[0057] The water soluble adhesive dissolves quickly, and migrates locally while in solution, provides extra toughness in the system, and helps to control bleed or pooling of fluid binder in selectively printed areas. A suitable water soluble adhesive is polyvinyl alcohol. More generally, suitable water-soluble adhesives may include water-soluble polymers, carbohydrates, sugars, sugar alcohols, organic acids, proteins, and/or inorganic compounds. Examples of water-soluble polymers include polyvinyl alcohol, sulfonated polystyrene, sulfonated polyester, polyethylene oxide, polyacrylic acid, octylacrylamide/acrylate/butylaminoethyl methacrylate copolymer, acrylates/octylarylamide copolymer, polyvinyl pyrrolidone, styrenated polyacrylic acid, polyethylene oxide, sodium polyacrylate, sodium polyacrylate copolymer with maleic acid, polyvinyl pyrrolidone copolymer with vinyl acetate, butylated polyvinylpyrrolidone, polyvinyl alcohol-co-vinyl acetate, starch, modified starch, cationic starch, pregelatinized starch, pregelatinized modified starch, pregelatinized cationic starch, and combinations and copolymers thereof.

[0058] The inclusion of a whitening agent may help raise the brightness (measured as L^*) of a printed article above that achievable with, e.g., plaster alone, imparting a more neutral white point. Neutral whites improve the contrast and quality of colors printed throughout the article, providing a greater color gamut. Preferably, the refractive index of the whitening agent is at least 1.9. Titanium dioxide is a suitable pigment with a refractive index of 2.4. Zinc oxide is an alternative pigment with a refractive index of 2.0. Other suitable whitening agents include a second water soluble adhesive, modified starches, clays, zinc sulfide, barium sulfate, zirconium silicate, lead carbonate, limestone, and hollow glass spheres, such as borosilicate glass spheres.

[0059] The whitening agent serves to make a printed article more “white.” This characteristic is measured as an increase of brightness L^* towards 100 (typical values are 80-90), and a decrease in chroma C^* (typical values 1-10) towards zero for the white point. A perfect white has the properties of $L^* = 100$, $C^* = 0$. An exemplary graph of L^* and C^* for

various materials suitable for use as a whitening agent in 3D printing is provided in Figure 5. Further discussion of L^* and C^* may be found in the optical brightener section herein, or in the literature. Using too much of some whitening agents may cause deep, saturated colors to look washed out in the final article. The whitening agent is preferably selected so as to not

5 compromise the chemistry of the article building process. Representative L^* and C^* data of some whitening agents with an experimental plaster powder for three-dimensional printing are shown in Figure 5. Here, several powders were individually pressed into dry pellets and then the top surface of the pellet was measured using a Greyttag MacBeth eye-One spectrophotometer for brightness L^* and chroma C^* . The white point of an experimental

10 powder initially measured is $L^* = 90$ and $C^* = 5.5$. With the addition of about 0.1 wt% titania, the white point of the experimental powder shifted to $L^* = 90.5$ and $C^* \sim 4$. The arrow on the chart loosely represents the expected path that the white point of the material would follow as TiO_2 is added to this system. This correction of the white point of the powder to a lighter, less chromatic white enables the creation of 3D printed articles with brighter and more accurate

15 color.

[0060] The whitening agent may be soluble in an aqueous solution of 5 wt% glycerol, with a solubility of at least 5 mg/liter. The whitening agent may be a water-soluble adhesive, such as a StarDri product manufactured by Tate & Lyle. In some embodiments, the whitening agent is a salt, such as very pure potassium sulfate or potassium aluminum sulfate. In other

20 embodiments, the whitening agent is a high whiteness starch, such as processed potato starch or derivatives thereof.

[0061] The inclusion of the acidic solid particulate additive (i.e., an acidifying agent) may inhibit the cure rate of the most commonly used infiltrant, cyanoacrylates. Cyanoacrylates cure via anionic polymerization in the presence of a weak base, such as water. When one attempts

25 to pour a cyanoacrylate resin onto an article that has not yet fully dried, water in the article may cause the cyanoacrylate to react on the surface of the article, thereby sealing the pores and preventing further infiltrant from penetrating into the article. Cyanoacrylates may be stabilized in their packaging by the addition of weak acids. Acids either consume that $-OH$ ion or prevent water from dissociating into H^+ and $-OH$ ions. The inclusion of certain weak acids in the

30 particulate mixture may retard the cure of a cyanoacrylate during the infiltration of an article formed by three-dimensional printing, allowing deeper penetration into the article, leading to the creation of stronger prototypes with dry and slightly damp articles.

[0062] Referring to Figure 6, the anionic polymerization of a cyanoacrylate has three stages. The base B reacts with the C=C bond, leaving a reactive group on the central carbon. The reaction continues until a reactive component reacts with an acid molecule A.

[0063] Several factors may be considered when choosing an acid to use as an inhibitor for an infiltrant such as cyanoacrylate. The primary concern is safety, because ingredients that are powerful acids are likely to be irritating at the least, or corrosive and deadly at worst. Secondly, some acids exist as hygroscopic solids. When left in humid environments, such as the region of unprinted powder adjacent a selectively activated article, these materials may become cakey and adhesive, forming undesired films on the sides of the article. Such films may lead to dimensional inaccuracy and/or a white haze over the colored regions of a printed article, significantly detracting from its utility, appearance, and value. Water solubility is a good indicator of how likely an acid is to form a visible film on the side of a part. A solubility range of 0 – 10 grams/100 mL of water is preferred.

[0064] The acid ionization constant of an acid, represented by pKa, is a measure of the propensity of a compound to donate a proton. Strong acids, i.e., those with a pKa < -2, dissociate fully. Acids with pKa > -2 are less likely to dissociate, and therefore are less likely to be in solution to participate in a plaster reaction. pKa values of various materials are readily available in the literature. Acids that work well as inhibitors for plaster-based systems infiltrated with a cyanoacrylate resin typically have a pKa selected from a range of 1-4.

[0065] An octanol-water coefficient K_{ow} of the acidic additive may fall within a range of -0.4 to 1. The octanol-water partition coefficient is the ratio of the concentration of a chemical in octanol and in water at equilibrium and at a specified temperature. Water solubility has been correlated to the K_{ow} of a material.

[0066] The pKa and log K_{ow} of various acids are indicated in Table 1.

Acid Name	pKa	log K_{ow}	sol (g/100 mL)
GdL	3.84	-1.98	59
EDTA	1.7	-3.86	0.05
Tartaric	3.2	-1	133
Fumaric	3.03	0.05	0.49
Citric	3.13	-1.67	175
HCl	-7	0.25	Miscible
HF	3.45		Miscible
Sulfuric	-2		Miscible
Maleic	1.87	0.05	78
Succinic	4.19	-0.75	7.8
Polyacrylic	5	0.35	Miscible
Orthophosphoric	2.16		Miscible
formic acid	3.75	-0.54	Miscible
Acetamide	15.1	-1.16	200
Methanol	15.5	-0.82	Miscible
Bis(2-ethylhexyl) phosphate	< 3	2.67	0.21
dibutyl phenyl phosphate	0.1	4.27	96
tris (2-ethylhexyl) phosphate	< 3	> 8	0
2,2-bis(chloromethyl) trimethylene bis[bis(2-chloroethyl) phosphate]	0 – 10	2.83	232

Table 1: pKa and log K_{ow} data for various acids

[0067] Figures 7 and 8 show the correlation of K_{ow} and pKa, respectively, with early strength and surface cake for several representative acids. Referring to Figure 7, the right axis of the graph indicates a measure of depowderability, with higher values of depowderability correlating to cylindrical holes with increasingly smaller diameters. These smaller holes are not clogged with partially set powder that can be caused by the evaporation of liquid in the printed article during the curing process. As the depowderability score increases, surface finish defects caused by powder caked into crevices decreases. The left axis of the graph reflects a measurement of the strength of an article taken via a 3 point bend test, i.e., a two hour green smbar strength (mPa). As the strength of an article, made from a particular powder, measured two hours after the completion of the build increases, the utility of that powder for making rapid prototyping parts increases. Both strength and depowderability increase for acids with a higher octanol-water partition coefficient (K_{ow}) (horizontal axis). This correlation is consistent with the premise that the plaster reaction proceeds more quickly with less soluble acids, and that less soluble ingredients are less likely to cause surface caking that may detract from the

accuracy or appearance of an article. Preferably, the solid particulate additive is not a catalyst affecting a rate of a reaction between the plaster and the aqueous fluid.

[0068] Referring to Figure 8, the left axis indicates the strength of an article measured 2 hours after the completion of the build, and the right axis indicates depowderability. Both of these values are correlated to the pKa of several acids. Acids where the pKa range from 1.5 to 4 may be used to print parts with a plaster based system. The system in question exhibited optimum, i.e., relatively highest, strength and depowderability with acids whose pKa is approximately 3.

[0069] The pKa changes the preferred amount of an acid that needs to be used to produce an article with a preferred combination of green part curing, appearance, accuracy, final infiltrated strength, and cure time. Referring to Figure 9, a three-dimensional plot is used to illustrate the relationship between the combined parameters of water solubility, octanol-water partition coefficient K_{ow} , and acid ionization constant pKa. The preferred region 901 of acidifiers for use in a plaster based powder system for 3D printing may be represented by a bounding box drawn from the union of the ranges $\log K_{ow}$ (-1 to -0.5), pKa (-2.8 – 3.2), solubility (0 – 10 g/100 mL). These parameters may be used to select acid components for use as inhibitors of cyanoacrylate in a plaster-based three-dimensional printing system. Optimization around any single parameter may lead to defects in strength, cure rate, and article appearance.

[0070] Figure 10 shows the impact of acidifer level on the final strength of a 3D printed article after infiltration with a cyanoacrylate resin (zbond101, by Z Corporation) and on the infiltrant curing rate in a series of powder formulations. Printed strength bars were dried in a 100° F convection oven for 24 hours and infiltrated with the zbond101. The strength of the articles was measured one hour after infiltration. This timing approximates the article-making choreography for an operator of a zprinter310 who is attempting to make a strong prototype article with the material system in question. A powder/infiltrant formulation is more useful if it achieves higher strength in a shorter amount of time. The variable changed in the experiment is the amount of tartaric acid in the powder, ranging from 0-1.2 wt%. Articles made with the powder containing less than 0.4% tartaric acid fully cured within the one-hour time frame. Curve 1001 represents the approximate strength of a cyanoacrylate infiltrated, 3D printed plaster based article over a range of Tartaric acid levels. For concentrations greater than 0.4 wt% acid, the cure of the cyanoacrylate is so substantially inhibited that the article is still weak one hour after infiltration. Curve 1002, representing the strength of the same articles measured

several days after infiltration shows that the articles in question eventually do become solid, attaining the full strength of articles made with lower levels of cyanoacrylate, though it may take in excess of two additional days for some systems to cure. As illustrated by the difference between curves 1001 and 1002, parts made with formulations with an excess of tartaric acid and then infiltrated with zbond101 take hours to days to achieve a full cure, and are not useful for conveniently making articles in the rapid prototyping field, i.e., they may not be adequately adapted for three-dimensional printing.

[0071] Acid concentration in the powder has an effect on the ease of use and on the final article performance. Overinhibiting the set of an infiltrant can cause the article to remain tacky and have low strength for an extended periods of time (hours), delaying the instant of use for the prototype. The delayed cure of an infiltrant may provide a stronger final article. Underinhibiting typically reduces the degree of infiltrant penetration, making the article weaker.

[0072] Some suitable acids for inhibiting the infiltrant reaction, e.g., a reaction with cyanoacrylate, are fumaric acid, tartaric acid, fatty acids, gluconic acids, adipic acid, glucono-delta-lactone (GdL), ethylenediaminetetraacetic acid, succinic acid, a phenolic compound, and combinations thereof.

[0073] Accelerators may be included in the particulate mixtures to control setting rates. For example, in plaster-based systems, accelerators may be used to control the set rate of the plaster during printing. Plasters that set too slowly allow various distortions associated with the volume changes during the dissolution and drying of most water soluble adhesives. Acceleration of plaster is typically achieved through the use of a combination of potassium sulfate and terra alba, though many other options are possible, including hydrated gypsum, potassium sulfate, and potassium aluminum sulfate.

25 ***Fluid binder***

[0074] In a preferred embodiment, a fluid binder is an aqueous fluid that includes or consists essentially of:

water	70 - 90 wt%
humectant	1 - 10 wt%
preservative	0.05 - 5 wt%
surfactant	0 - 2 wt%
optical brightening agent	0 - 5 wt%

The aqueous fluid may also include rheology modifiers at a concentration of 0.01 - 5 wt%. As discussed below, the aqueous fluid may include a fluorescent brightener based on stilbene chemistry or distyrylbipheyl.

5 [0075] Humectants may serve to keep the nozzles of the print head from drying out and forming a crust when uncapped, such as during the period when the print head is not firing droplets but moving over the build area to a new position. The type and concentration of a humectant may also influence the dynamics of droplet formation, the consistency of drop trajectory, and the curing of the article formed by three-dimensional printing. Examples of suitable humectants include Glycerol and other diols from 3-10 carbons long; many other
10 examples of humectants are known in the art. Printing can be successful with humectant levels from 1-20% depending on the binder formulation.

[0076] The preservative may serve to prolong the shelf life of the fluid as manufactured, as well as to extend its useful life in the machine. Preservatives may have detrimental effects on print quality, and in some cases on the appearance or curing of the article being formed by
15 three-dimensional printing. It is generally desirable to choose environmentally friendly, stable, and substantially clear preservatives. An example of a suitable preservative includes the Proxel GXL, manufactured by Arch Chemical. Many other suitable preservatives are available in the industry.

[0077] Surfactants are typically used to control the surface tension of the aqueous fluid.
20 Proper surface tension helps ensure that the droplets being ejected from a print head are formed with a consistent volume, depart from the print head at the appropriate vector, and that they do not form satellite drops. Very high surface tension may create poor wetting when the binder impacts loose powder. Low surface tension may create poor droplet formation at the face of the print head. Surface tensions of successful binders for use with an HP11 print head range
25 from 30 dynes/cm to 36 dynes/cm. Suitable surfactants include Surfynol CT-171, Surfynol 465, and Surfynol 485 in ranges from 0.24wt% to 1.5wt%. Such products are available from Air Products. The range of viscosities of the aqueous fluid suitable for use with HP11 print heads is 1 - 1.35 cps. pH of the fluid can also have impact on the safety of the product, the effect of the binder on the reaction rate of the plaster, and the compatibility of the fluid with the
30 materials of construction of the machine. An acceptable range of pH for the aqueous fluid is from 4.9 to 10.3.

[0078] The aqueous fluid may be used for three-dimensional printing, such that an article printed with the aqueous fluid comprising the optical brightening agent has a lower chroma C^* than an article printed with the aqueous fluid without the optical brightening agent. Optical brighteners are used to color correct the whiteness of a three-dimensional printed part. Optical brightening agents increase the perceived whiteness of an article by absorbing ultra violet light <400 nanometers (nm) and re-emitting blue light typically between 400 and 450 nm, increasing the reflected light in the visible spectrum. Figure 11 illustrates the operating principle behind fluorescent brightening; the image is taken from Ciba Specialty Chemicals publication number 016263.040e/CH; April 1999, edited in Switzerland. Figure 11 shows an exemplary graph of optical density vs. wavelength of light, expressed in nm. Optical density is a measure of the absorbance of an optical element for a given wavelength of light. Light in the UV spectrum (curve 1101), i.e., from 200 nm to 400 nm, is absorbed by a fluorescent brightener, and re-emitted (curve 1102) in the blue wavelengths of the visible spectrum, which peak at around 475 nm. The lost UV portion of the light is not detected by the human eye.

[0079] The blue fluorescence of the optical brightener helps to overcome the natural yellowness of the other raw materials. Quantitatively, this may be expressed as higher emission in the blue reflectance, as shown in Figure 12. Figure 12 is a plot of %reflectance versus wavelength as measured on a three-dimensional printed plaster article that was printed using the UvitexRSB optical brightener, and demonstrates the depression of the reflected light measured below 420 nm (region 1201) with a corresponding increase to the reflectance measured from 425 nm to approximately 500 nm (region 1202). Reflected light from the UV region of samples of a plaster-based article treated with fluorescent brightener was measured. The yellow cast of an article is counteracted as fluorescence increases the amount of light emitted in the blue wavelengths (430-460 nm). Higher concentrations of the optical brightener, e.g. UvitexRSB, increase the amount of fluorescence.

[0080] Referring to Figure 13, the effect of the optical brightener may also be shown in an a^* , b^* plot of the white point of a plaster article printed with the aqueous fluid containing an optical brightener. In this plot, the a^* axis represents colors from green to red and the b^* axis represents the spectrum from yellow to blue. The addition of a fluorescent brightener to a nominally white three-dimensional printed article shifts the color of the reflected light away from the yellow ($+b^*$) towards ($b^*=0$), while inducing a slight increase in a^* as the

concentration of the brightener is increased. This may create a slight purple cast in the article if too much optical brightener is used.

[0081] Figure 14 is a plot of L^* lightness versus C^* chroma for a nominally white 3D plaster article as the concentration of Uvitex RSB is increased in the aqueous fluid from 0 – 1.5wt%.

5 A perfect white would have $L^*=100$ and $C^* = 0$. Chroma $C^* = \sqrt{a^{*2} + b^{*2}}$. In Figure 14, C^* continuously decreases as the brightness L^* remains essentially unchanged up to 1.5 wt% of optical brightener in the aqueous fluid. C^* of the white point is reduced by a factor of 2 as the concentration of optical brightener is increased from 0 – 1.5 wt% of the fluid, applied to a plaster-containing three-dimensional printing powder. Figure 14 provides specific data
10 regarding the effect of concentration of UvitexRSB on brightness and chroma of a white three-dimensional printed article. As one can see, the addition of fluorescent brighteners to an aqueous fluid may result in the reduction of chroma C^* with little to no impact on the brightness of the article.

[0082] Some powdered whitening agents can overwhelm the capability of the dyes to create
15 deep colors in the final article, especially if used in concentrations that completely correct chroma (C^*) defects. Using whitening agents in combination with an optical brightener in a binder/powder system can increase the color gamut in white and lightly colored regions more effectively than can be achieved with whitening agents alone. In a preferred embodiment, the optical brightener is only in the clear binder channel, as putting optical brighteners into deep
20 colors, such as black, is unnecessary.

[0083] Optical brighteners, also known as fluorescent brighteners, are generally classified into the following six classes by Zollinger: stilbenes, 1,2-ethylene derivatives with two heteroaromatic residues, derivatives of coumarins, derivatives of 1,3-diphenyl-2-pyrazoline, naphthalimide compounds, and compounds obtained by direct linking of aromatic and
25 heteroaromatic rings. In some embodiments of the invention, water soluble stilbenes with two to six sulfonate groups may be useful with concentrations ranging from 0 to 2 wt%. The brightener is preferably stable during the printing process. Stilbenes and Distyrylbiphenyl, with two to six sulfonate groups showed the best combined printability and optical brightening behavior. Examples of suitable optical brightening agents include products such as Uvitex
30 NFW, Tinopal MSP, and Tinopal SFP, manufactured by Ciba, and Uvitex RSB, manufactured by Huntsman.

[0084] The aqueous fluid is preferably substantially clear, so as to not depress the brightness L^* of the article, or increase its chroma C^* .

Kits

5 [0085] Particulate materials and aqueous fluids may be used together to enhance the whiteness and brightness of articles formed by three-dimensional printing. A preferred kit includes a powder adapted for three-dimensional printing, and an aqueous fluid for activating water soluble components of the three-dimensional printing powder. The powder may include a loose, dry, and substantially free-flowing particulate mixture including a water-soluble
10 adhesive, plaster, a plaster accelerator, a whitening agent having an L^* of at least 90 and a C^* of up to 5.5, and a solid particulate additive including an acid. The aqueous fluid may include water, a humectant, a surfactant, a preservative, and an optical brightening agent in a range of about 0.05 to about 5 wt%.

[0086] The particulate material is adapted for use in three-dimensional printing to form an article
15 comprised of a plurality of layers, the layers including a reaction product of the particulate material and the aqueous fluid that contacts the particulate material during three-dimensional printing. The acid has a water solubility selected from a range of about 0 – 20 g/100 mL of water, a pKa selected from a range about 1 to about 4, and a K_{ow} selected from a range of -about 0.4 to about 1, and is adapted for modifying a cure rate of an infiltrant to facilitate penetration of the
20 infiltrant into the article. The particulate mixture is substantially free of plaster retarders. The aqueous fluid is substantially clear, has a viscosity selected from a range of 1-1.35 cps, a surface tension selected from a range of 30-36 dynes/cm, and a pH selected from a range 4.9 to 10.3. The kit may also include a combination of binders comprising cyan, magenta, and yellow binders.

25 [0087] In another preferred embodiment, the powder includes a substantially dry particulate mixture including a water-soluble adhesive, a partially soluble filler, an accelerator, and a solid particulate additive comprising an acid. It also includes an the aqueous fluid including water, a humectant, a preservative, and an optical brightening agent. The particulate material is suitable for use in three-dimensional printing to form an article comprised of a plurality of layers, the layers
30 including a reaction product of the particulate material and a aqueous fluid that contacts the particulate material during three-dimensional printing. The additive has a pKa of between 1 and 4, and a K_{ow} selected from a range of -0.4 to 1, and is suitable for modifying a cure rate of an

infiltrant to facilitate the penetration of the infiltrant further into the article. The kit may include a combination of binders including cyan, magenta, and yellow binders.

Printing method

5 [0088] An article may be formed by three-dimensional printing as described above. In particular, a substantially dry particulate material may be provided, comprising a plurality of adjacent particles, the particulate material being substantially dry and including a water-soluble adhesive, an accelerator, and at least one of (i) a whitening agent and (ii) an acidic additive for controlling the cure rate of an infiltrant. A fluid binder is applied to at least some of the
10 particles in an amount sufficient to bond those particles together to define at least a portion of the article, the fluid binder may include one or more of the following components: water, a humectant, a rheology modifier, a surfactant, a preservative, and an optical brightening agent. The article may be bonded without mechanical agitation and/or supplemental electromagnetic radiation of the particulate material. The bonded particles may define layers including a
15 reaction product of the particulate material and the aqueous fluid that contacts the particulate material during three dimensional printing, with the particulate material being capable of supporting the article during three dimensional printing and suitable for being spread in a layer of dry particles having a thickness selected from a range of about 12 to about 125 μm .

[0089] The article may develop a strength of at least 1 MPa within one hour of being printed.
20 This rapid development of strength is due, in the preferred embodiment, to the setting of the plaster filler. The dissolution and drying of the water soluble adhesive adds toughness to the article.

Flow Properties of Build Materials

25 [0090] Compositions have been disclosed that relate to control of the flow properties of the build material in three-dimensional printers. The three principle methods are the addition of liquid "processing aids," control of grain size distribution, and the addition of solid fillers that contribute to the frictional behavior of the build material. Many candidate materials have been disclosed previously, for example, in U.S. Patent Publication Number 2005/0003189.

30 Previously, however, the exact implementation of these methods has been by trial and error. Here, some mechanical properties of dry particulate build materials are disclosed that are

particularly suited for use in three-dimensional printing, especially in contrast to other formulations of similar materials for other uses that may not require special flow characteristics of the raw materials.

[0091] Referring to Figure 15, in an embodiment of a three-dimensional printer, dry, free-flowing particulate build material is spread by a rotating spreader rod 1500. The rod rotates in a direction counter to the direction of motion of the spreading mechanism. A circulating bead 1510 of build material 32 is pushed in front of a moving rod over a stationary bed. For the sake of convenience, the system is shown in the frame of the rod with a moving bed 1520 and stationary bead. The bed is assumed to approach the spreader, and the bead of build material circulates around a nearly stationary center. One may assume that the build material is lifted by the leading surface of the spreader rod because it adheres to the rod surface 1530. The direction of the flow of the build material reverses close to a nip 1540, i.e., an interface between the spreading roller 1500 and the moving bed 1520

[0092] The equilibrium of a small printed feature as it passes directly underneath the spreader rod is analyzed. On typical three-dimensional printers, the thickness t of a single printed layer of build material 32 is approximately $1/100$ the radius of the spreader rod. Referring to Figure 16, the spreader exerts a compressive stress σ_{zz} and a shear stress τ_{xz} on the build material directly underneath it. There is also a horizontal stress component σ_{xx} .

[0093] One may assume that the horizontal stress applied to the left edge 1600 of the feature is not opposed by another stress on the right edge 1610. The feature is assumed to leave a wake 1620 behind it where build material, after being swept along the upper surface, is unable to wrap around the downstream corner and establish a stress analogous to hydrostatic pressure against the right surface. The horizontal stress applied to the left may be opposed by a shear stress along the bottom surface. A free body diagram of the feature is shown in Figure 16b, including a hollow cavity 1630 formed in the feature wake 1620.

[0094] It is assumed here that dry, free-flowing particulate build material in motion possesses a different shear strength than build material that has been allowed to rest for a time. In general, one may expect a different yield locus for build material in different states of motion. For purposes of this derivation, this is expressed here as two different sets of yield parameters, "static" and "dynamic" values of the cohesion and friction angle.

[0095] These properties of particulate materials are amply supported in the literature. See, for example, B.M. Das, *Advanced Soil Mechanics*, Hemisphere Pr. 1997, pp. 315-317 or S. Aranson & L. S. Tsimring in *The Physics of Granular Media*, H. Hinrichsen & D. Wolf, eds, Wiley-VCH, (2004) pp. 146-147, incorporated herein by reference in their entirety.

5 A force balance on the feature shown in Figure 17 leads to the equation:

$$l [c_s - c_d + \sigma_{zz} (\tan\phi_s - \tan\phi_d)] = L \Delta\tau > t\sigma_{xx} \quad (3)$$

for the feature to remain in place. The normal stress against the bottom surface of the feature is assumed the same as that against the top surface. The difference in shear strength between the static values (static yield locus 1700) and dynamic values (dynamic yield locus 1710) with

10 normal stress σ_{zz} is denoted by $\Delta\tau$.

[0096] “Bredt flow parameter” (Br) is herein defined, expressing, in general, the propensity for printed features to shift in the build area of a three-dimensional printer during spreading of build material:

$$\Delta\tau / \sigma_{xx} = Br > t / L \approx 0.1 \quad (4)$$

15 [0097] The ratio t/L is slightly arbitrary. One may assume for practical purposes that features with a length at least several times the layer thickness ($L \sim 10$ times t) are those that are preferably considered in this model. Layers with thickness of 100 μm are standard in three-dimensional printing machines that are currently available, and instability of isolated patches smaller than 1.0 mm may have a minimally discernable effect on the appearance of a model.

20 [0098] For the flow conditions most useful for three-dimensional printing, the build material is non-cohesive, i.e., the cohesion of the particulate material is much less than the dynamic pressure of material in flow. Using reasonable values for the bulk density of the build material and spreading speed in a standard ZPrinter®310 three-dimensional printer, one obtains an order of magnitude estimate:

$$25 \quad c_s \approx c_d \ll \rho(u+\omega a)^2 \approx 600 \text{ Pa} \quad (5)$$

[0099] A material having shear strength of this magnitude is a weak gel such as yogurt. While it is not “strong” in any sense of the word, it is by no means “free-flowing.” As an additional estimate of the lower bound of the cohesion, we may observe that the bead of free-

flowing particulate build material may be in a state of yielding at the bottom of the pile when the counter-roller begins to move it across the build area. In a ZPrinter®310 three-dimensional printer, the bead is approximately 1 cm tall. Accordingly, we require the following inequality to hold:

5 $c_s \approx c_d \ll \rho gh \approx 100 \text{ Pa} \quad (6)$

[0100] This is typically a minimum acceptable range for cohesion in a particulate build material for it to be considered “free-flowing.” While the compressive and shear stress imposed on the build material through the motion of the counter-roller may have a magnitude approximately 600 Pa, the cohesion is preferably accordingly less than 100 Pa in order for it

10 not to adversely affect the layering of build material.

[0101] With the assumption that the cohesion is negligibly small, the following simplification can be made.

$(\tan\phi_s - \tan\phi_d) > t \sigma_{xx} / L \sigma_{zz} \quad (7)$

and

15 $\frac{\sigma_{xx}}{\sigma_{zz}} = \frac{(1 + \sin\phi_d)}{(1 - \sin\phi_d)} \quad (8)$

This leads to an equation

$$(\tan\phi_s - \tan\phi_d) \frac{(1 - \sin\phi_d)}{(1 + \sin\phi_d)} = Br_{nc} > 0.1 \quad (9)$$

Equation 9 expresses a vitally important feature of free-flowing particulate build materials that are suitable for use in three-dimensional printing machines. The quantity on the left, Br_{nc} , is

20 termed the “Bredt flow parameter for noncohesive particulate materials,” and it preferably has a value greater than about $1/10$ for small printed features to remain stationary during spreading.

Measurement of static and dynamic friction coefficients

[0102] Methods exist for measuring the static yield properties of particulate materials in shear. See, for example, B.M. Das, *Advanced Soil Mechanics*, Hemisphere Pr. 1997, pp 313-326. It is found, however, that the values for the yield parameters ϕ and c vary with experimental conditions, and it is necessary to measure the properties in stress range of interest.

[0103] An example of a piece of laboratory equipment that is capable of measuring the static friction characteristics of particulate materials is the "ShearScan TS12" manufactured by Sci-Tec Inc. This device holds a sample of material in a cylindrical cell and applies a vertical load to the material to consolidate it to a specified level. The device then applies a gradually increasing transverse shearing force until it detects slip in the sample of material. It performs this measurement across a range of applied loads to develop a yield locus analogous to those pictured in Figure 17. Since the instrument measures the shear stress at the instant of rupture, this is the "static" friction in the particulate material.

[0104] One difficulty in this analysis with the ShearScan instrument is that it is designed to measure the frictional characteristics of particulate materials in large silos when they are subjected to stress levels much larger than that found in the spreading system of a three-dimensional printer. The stress was estimated in equation (5) above to be on the order of $\frac{1}{2}$ kPa, about $\frac{1}{10}$ the stress levels in the operating range of the ShearScan.

[0105] Furthermore, there does not exist an analogous instrument to measure the "dynamic" friction characteristics of particulate materials. Several instruments called "powder rheometers" exist, for example the FT4 Powder Rheometer manufactured by Freeman Technology. This device doesn't strictly measure a yield locus, however. It measures the rate of working of a particulate material in a specialized mixing cell where the stresses in the sample are not known. It is therefore not suitable for use in this model.

[0106] An approximate laboratory procedure may provide estimates of the flow parameter for non-cohesive particulate build materials. This is done by measuring the angle of repose of a pile of a particulate material under static and dynamic conditions. The procedure is accomplished as follows. On an unpolished type 304 stainless steel sheet with a 2B mill finish and a dimension of 12 inches square by 0.060 inches in thickness available from McMaster-Carr based in Elmhurst, IL, a conical pile is formed from a particulate material sample by sprinkling particles very slowly at a bulk volumetric flow rate of 30 +/- 15 mL per minute over

one point using a 385 mL stainless steel funnel available from Lab Safety Supply in Janesville, WI from a height of about 1 cm above the growing top of the pile.

[0107] The height of the pile is chosen such that

$$gh \approx (u + \omega a)^2$$

5 [0108] This ensures that the stress at the bottom of the heap is in approximately the right range. For ordinary three-dimensional printers manufactured by Z Corporation, this height is roughly 2 inches.

[0109] The initial diameter, d , and height, h , of the pile are measured. The ratio $2h/d$ is an approximate measure of the static friction coefficient $\tan \phi_s$. Next, a small impact force
10 delivered from an 18-8 stainless steel slotted spring pin, $\frac{1}{2}$ inch in diameter and 2.25 inches long with a mass of 32.0 +/- 0.5 grams available from McMaster-Carr dropped onto the edge of the stainless steel sheet from a height of 0.65 +/- 0.02 inches so the pile collapses. It is necessary to deliver to the plate a relatively light impact so that the motion of the pile after the impact is primarily driven by gravity and not by kinetic energy. Two impacts may be
15 sufficient. The final height and diameter of the collapsed pile are measured, and the ratio $2h/d$ is an approximate measure of the dynamic friction coefficient $\tan \phi_d$.

[0110] Several particulate samples were measured in this manner, and the data are presented below. The calculated flow parameter is the “noncohesive” form given in equation 9.

Particulate sample	tan phi s	tan phi d	Br _{nc}
zp100	0.83	0.52	0.11
zp100	0.91	0.45	0.19
zp100	1.00	0.65	0.10
zp130	0.65	0.35	0.15
zp130	0.74	0.40	0.16
zp130	0.79	0.45	0.14
4F Lucite	0.53	0.28	0.14
50 μm Al ₂ O ₃	0.64	0.44	0.09
Coated glass beads	0.45	0.35	0.05
+10 ppm Neobee M20	0.46	0.32	0.07
+20 ppm Neobee M20	0.52	0.33	0.10
+30 ppm Neobee M20	0.67	0.53	0.05
+40 ppm Neobee M20	0.79	0.69	0.03
+50 ppm Neobee M20	0.78	0.76	0.00

Table 2. Measurements of flow parameter for various candidate particulate build materials

- zp100 and zp130 are products marketed by Z Corporation for building appearance models.
- 4F Lucite from Ineos Acrylics has a particle size between 55 μm and 70 μm.
- 5 • Tabular 50 μm Al₂O₃ acquired from KC Industries
- Glass Beads from Potter’s Industries, 72 μm grain size, aminosilane surface treatment
- Neobee M20 was used to coat glass beads. Neobee M20 from Stepan Industries

[0111] As these data approximately show, build materials designed by Z Corp for three-dimensional printing all fall in the same range, a little bit higher than the required lower bound.

10 Some scatter in the results is to be expected with this approximate technique. Although the static angle of repose of zp100 is higher than in zp130, the flow parameter for the two build materials is nearly the same. In fact, qualitative experience shows that these two products perform about the same.

[0112] Of the other three materials tested, glass spheres alone had the poorest performance, with a flow parameter of only about 0.05. This, too, is supported by qualitative experience: glass beads alone are unsuitable for three-dimensional printing from the standpoint of spreading. However, glass beads may be mixed with various processing aids and with other particulate materials that may be finer or equal to in particle size having a non-spherical and irregular particle shape to achieve a desirable Bredt parameter greater than 0.10, thereby being suitable for use in three-dimensional printing.

[0113] To illustrate the extreme sensitivity of particulate behavior with even small additions of certain chemicals, generally referred to as "processing aids," a series of data were taken in which tiny (10 ppm) increments of a low-viscosity emulsifier are added to a sample of glass spheres. The flow parameter rises quickly, peaks, and falls away even more quickly even though both the static and dynamic friction angles increase through the series. The critical point occurs when the dynamic angle of repose transitions from a nearly constant value to a linearly increasing value. This shows that there can be rather sharp optima in composition to obtain useful spreading characteristics.

[0114] This test is a fairly useful technique for identifying relative performance properties between different candidate materials. The preferred method for evaluating flow properties of candidate build materials during formal optimization after the initial selection period is to test samples of the material on a working three-dimensional printer. Certain pathological geometries are known to those experienced in the art, and they can be evaluated either qualitatively or quantitatively. One particularly useful geometry for observing stability during spreading is a flat plate studded with pegs that are oriented downward during the build. During printing, the earliest layers addressed are a series of disconnected patches that are relatively free to shift in the build material. After these have been formed, a plate is printed that joins all of the pegs together in a single object. One can easily examine whether the pegs are uniform and straight, and one can evaluate the quality of spreading on that basis.

Additional Flow Properties of Build Materials

[0115] Compositions have been disclosed that relate to control of the flow properties of the build material in three-dimensional printers. The three principal methods are the addition of liquid “processing aids,” control of grain size distribution, and the addition of solid fillers that contribute to the frictional behavior of the build material. Many candidate materials have been disclosed previously, for example, in U.S. Patent Publication Number 2005/0003189, the disclosure of which is incorporated herein by reference in its entirety. Some mechanical properties of dry particulate build materials are disclosed in the following discussion that are particularly suited for use in three-dimensional printing, especially in contrast to other formulations of similar materials for other uses that do not require special flow characteristics of the raw materials.

[0116] A method that may be used to quantify a particulate material’s suitability for three-dimensional printing includes placing 1 liter in bulk volume of a particulate material in a metal cylinder with an inside dimension of 6.1 inches, and inside height of 6.2 inches so that the height of the powder is between 2.5 to 3.0 inches when the cylinder is capped with a translucent cover and laid on its side (i.e., the height of the cylinder is horizontal). The drum is then slowly rolled with a rotational velocity of 2.5 rotations/min +/- 0.5 rotations/min until the powder reaches an angle where it avalanches upon itself. The distance that the drum rolled, s , is recorded and the angle, ϕ , can be determined from equation 10:

$$\phi = \frac{s}{r} \cdot \frac{180}{\pi} \quad (10)$$

where r would equal the outside radius of the drum. The angle, ϕ , is the internal angle of friction that particulate material has under these particular test conditions at a room temperature between 65 to 75°F. Various particulate materials known to have good and bad spreading characteristics are compared using this test method, and desirable range of internal angles of friction were determined. Table 3 summarizes the particulate material compositions that were measured.

Ingredient	Powder composition							
	A	B	C	D	E	F	G	H
Potter's Spherglass 2530 CP03	84.64%		79.72%			100%	99.8%	
Zinc Oxide Pigment			4.75%					
Lucite Elvacite 2014	15.00%		15.19%					
Mineral Oil	0.19%		0.18%				0.2%	
Cobalt Octoate, 65% in Mineral Spirits	0.17%		0.16%					
Z Corporation zp131		100%						
Z Corporation zp102				100%				
Z Corporation zp100					100%			
Z Corporation zp130								100%
Internal Angle of Friction +/- 95% Confidence Interval	77°+/-3°	52.6° +/- 4.9°	36°+/-3°	53°+/- 12°	59°+/- 13°	32°+/-3°	81°+/-9°	48°+/- 5°
Three Dimensional Printing suitability	Too Cohesive	Good	Too Flowable	Good	Good	Too Flowable	Too Cohesive	Good

Table 3

Based on the results indicated in Table 3, one can conclude that powders that have an internal angle of friction greater than 40° and less than 70° are suitable for three dimensional printing in systems that use layers on the order of 125 μm.

- 5 [0117] Figure 18a is an exemplary CAD drawing of a test geometry that exhibits the distortion caused by the dragging of an article in a powder that is too flowable. Figures 18b and 18c are surface finish scans from a VIKING laser profilometer from Solarius. The figures

- 37 -

show a 3D topographical representation of articles formed by three-dimensional printing. In Figure 18b, a scan of an article made with zp131 from Z Corporation exhibits smooth, even contours that closely follow the intended CAD data. Figure 18c is a scan of a typically “too flowable” powder with an internal friction angle $<40^\circ$; the powder is too flowable and unable to resist the spreading forces causing previously printed layers to be displaced, resulting in an article that has a rough and uneven surface finish, or even has displaced artifacts missing from the surface of the article. The arrow in Figure 18c shows where geometry has shifted during printing.

[0118] Figure 19a is a CAD drawing of the formed article illustrated in Figures 19b and 19c. Referring to Figure 19b, as one may expect, a particulate material with an internal angle of friction that is between 40° and 70° , e.g., zp131, provides a smoother finish than a particulate material with an internal angle of friction greater than 70° (Figure 19c) where the powder is too cohesive to spread an even layer of particulate material, resulting in an article that has a rough and uneven surface finish.

[0119] This test, i.e., determination of an internal angle of friction, is a useful technique for identifying relative performance properties between different candidate materials. The preferred method for evaluating flow properties of candidate build materials during formal optimization after initial selection is to test samples of the material on a working three-dimensional printer. Certain pathological geometries are known to those experienced in the art, and they can be evaluated either qualitatively or quantitatively. One particularly useful article for observing stability during spreading is a flat plate studded with pegs that are oriented downward during the build. During printing, the earliest layers addressed are a series of disconnected patches that are relatively free to shift in the build material. After these have been formed, a plate is printed that joins all of the pegs together in a single object. One can easily examine whether the pegs are uniform and straight, and one can evaluate the quality of spreading on that basis.

[0120] Those skilled in the art will readily appreciate that all parameters listed herein are meant to be exemplary and actual parameters depend upon the specific application for which the methods and materials of the present invention are used. It is, therefore, to be understood that the foregoing embodiments are presented by way of example only and that, within the

- 38 -

scope of the appended claims and equivalents thereto, the invention may be practiced otherwise than as specifically described.

[0121] What is claimed is:

- 1 1. A powder adapted for three-dimensional printing, the powder comprising:
2 a loose, dry, and substantially free-flowing particulate mixture comprising:
3 a water-soluble adhesive;
4 plaster;
5 a plaster accelerator;
6 a whitening agent having an L* of at least about 90 and a C* of up to about 5.5;
7 and
8 a solid particulate additive comprising an acid,
9 wherein (i) the particulate material is adapted for use in three-dimensional printing to form an
10 article comprised of a plurality of layers, the layers including a reaction product of the particulate
11 material and an aqueous fluid that contacts the particulate material during three-dimensional printing,
12 and (ii) the acid has a water solubility selected from a range of about 0 – 20 g/100 mL of water,
13 a pKa selected from a range about 1 to about 4, and a K_{ow} selected from a range of -about 0.4 to
14 about 1, and is adapted for modifying a cure rate of an infiltrant to facilitate penetration of the
15 infiltrant into the article, and (iii) the particulate mixture is substantially free of plaster
16 retarders.
- 1 2. The powder of claim 1, wherein the substantially dry particulate mixture has a
2 Bredt parameter of at least about 0.10.
- 1 3. The material system of claim 1, wherein an internal angle of friction of the
2 particulate material has a value selected from a range of 40° to 70°.
- 1 4. The powder of claim 1 wherein the particulate mixture comprises about 0.01%
2 to about 5% by weight of the whitening agent.
- 1 5. The powder of claim 1, wherein a refractive index of the whitening agent is at
2 least about 1.9.
- 1 6. The powder of claim 1 wherein the whitening agent has a solubility in an
2 aqueous solution of 5 wt% glycerol of at least about 5 mg/liter.

- 1 7. The powder of claim 1 wherein the whitening agent comprises a second water-
2 soluble adhesive.
- 1 8. The powder of claim 1 wherein the whitening agent is selected from the group
2 consisting of a high whiteness starch and a high whiteness starch derivative.
- 1 9. The powder of claim 1 wherein the whitening agent is insoluble in an aqueous
2 solution of 5 wt% glycerol.
- 1 10. The powder of claim 1 wherein the whitening agent is selected from the group
2 consisting of zinc oxide, titanium dioxide, hollow glass spheres, limestone, a clay, and
3 combinations thereof.
- 1 11. The powder of claim 1 wherein the water-soluble adhesive comprises polyvinyl
2 alcohol.
- 1 12. The additive of claim 1 where the pKa is about 3 and the K_{ow} is selected from a
2 range of about -0.5 to about 0.5.
- 1 13. The powder of claim 1 wherein the particulate mixture comprises about 0.01%
2 to about 5% by weight of the solid particulate additive.
- 1 14. The powder of claim 1 wherein the solid particulate additive is selected from the
2 group consisting of fumaric acid, tartaric acid, gluconic acids, adipic acid, glucono-delta-
3 lactone (GdL), ethylenediaminetetraacetic acid, succinic acid, a phenolic compound, and
4 combinations thereof.
- 1 15. The powder of claim 1, wherein the plaster is selected from the group consisting
2 of plaster of paris, sulphate of lime, hydrated calcium sulphate, dental plaster, $CaSO_4 \cdot \frac{1}{2}H_2O$,
3 $CaSO_4 \cdot 2H_2O$, and combinations thereof.
- 1 16. The powder of claim 1, wherein the plaster accelerator is selected from the
2 group consisting of hydrated gypsum, potassium sulfate, potassium aluminum sulfate, and
3 combinations thereof.

- 1 17. The powder of claim 1 wherein the solid particulate additive is not a catalyst
2 affecting a rate of a reaction between the plaster and the aqueous fluid..
- 1 18. An aqueous fluid for activating water soluble components of a three-dimensional
2 printing powder, the aqueous fluid comprising:
3 water;
4 a humectant;
5 a surfactant;
6 a preservative; and
7 about 0.05 – about 5 wt% of an optical brightening agent;
8 wherein the fluid is substantially clear, has a viscosity selected from a range of 1-1.35
9 cps, a surface tension selected from a range of 30-36 dynes/cm, and a pH selected from a range
10 of 4.9 to 10.3.
- 1 19. The aqueous fluid of claim 18 wherein the optical brightening agent comprises a
2 fluorescent brightener based on stilbene chemistry or distyrylbiphenyl.
- 1 20. A kit comprising:
2 a powder adapted for three-dimensional printing, the powder comprising:
3 a loose, dry, and substantially free-flowing particulate mixture comprising:
4 a water-soluble adhesive;
5 plaster;
6 a plaster accelerator;
7 a whitening agent having an L* of at least about 90 and a C* of up to about 5.5;
8 and
9 a solid particulate additive comprising an acid, and
10 an aqueous fluid for activating water soluble components of the powder, the aqueous
11 fluid comprising:
12 water;
13 a humectant;
14 a surfactant;
15 a preservative; and
16 about 0.05 – about 5 wt% of an optical brightening agent,

17 wherein (i) the particulate material is adapted for use in three-dimensional printing to form an
18 article comprised of a plurality of layers, the layers including a reaction product of the particulate
19 material and the aqueous fluid that contacts the particulate material during three-dimensional printing,
20 and (ii) the acid has a water solubility selected from a range of about 0 – 20 g/100 mL of water,
21 a pKa selected from a range about 1 to about 4, and a K_{ow} selected from a range of -about 0.4 to
22 about 1, and is adapted for modifying a cure rate of an infiltrant to facilitate penetration of the
23 infiltrant into the article, (iii) the particulate mixture is substantially free of plaster retarders,
24 and (iv) the aqueous fluid is substantially clear, has a viscosity selected from a range of 1-1.35
25 cps, a surface tension selected from a range of 30-36 dynes/cm, and a pH selected from a range
26 4.9 to 10.3.

1 21. A method for forming an article by three-dimensional printing, the method comprising
2 the steps of:

3 providing a loose, dry, and substantially free-flowing particulate mixture comprising a
4 plurality of adjacent particles, the particulate mixture comprising a water-soluble adhesive,
5 plaster, a plaster accelerator, a whitening agent and a solid particulate additive comprising an
6 acid; and

7 applying to at least some of the plurality of particles an aqueous fluid in an amount
8 sufficient to bond those particles together to define at least a portion of the article, the aqueous
9 fluid comprising water, a humectant, a surfactant, a preservative, and an optical brightening
10 agent,

11 wherein the defined portion of the article solidifies without mechanical agitation
12 and without supplemental electromagnetic radiation.

1 22. The method of claim 21, wherein the article formed by the method develops a strength
2 of at least 1 MPa within about one hour of being formed.

1 23. The method of claim 21, further comprising infiltrating the article with a cyanoacrylate-
2 based adhesive, wherein the article develops a final ultimate infiltrated strength within one hour
3 of infiltration.

- 1 24. An essentially solid article manufactured by a three-dimensional printing process, the
2 essentially solid article comprising a product of the reaction of a mixture comprising:
3 a particulate material including a water-soluble adhesive, a partially soluble filler, an
4 accelerator, an additive having a pKa selected from a range of about 1 to about 4, and a K_{ow}
5 selected from a range of about -0.4 to about 1 and a whitening agent; and
6 an aqueous fluid comprising water, a humectant, a rheology modifier, a surfactant, a
7 preservative, and an optical brightening agent,
8 wherein the particulate material is reacted with at least a portion of the aqueous fluid to
9 form the essentially solid article including a plurality of essentially evenly distributed layers of
10 the reaction product.
- 1 25. The article of claim 24 wherein the article further comprises a cyanoacrylate-based
2 adhesive, and has a final ultimate strength greater than 15 MPa.

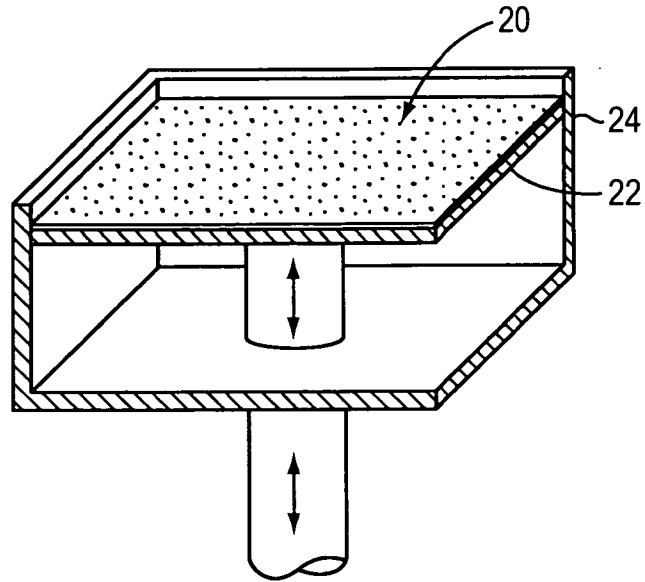

FIG. 1

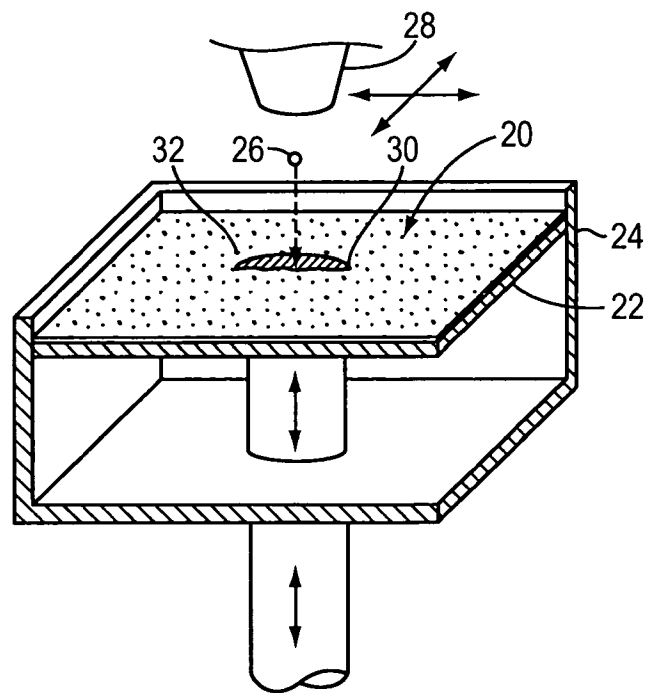

FIG. 2

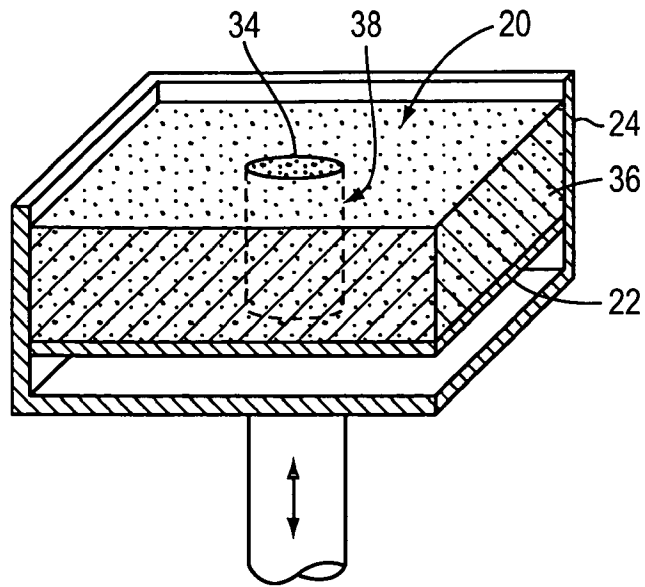

FIG. 3

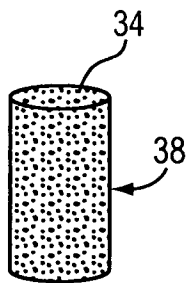
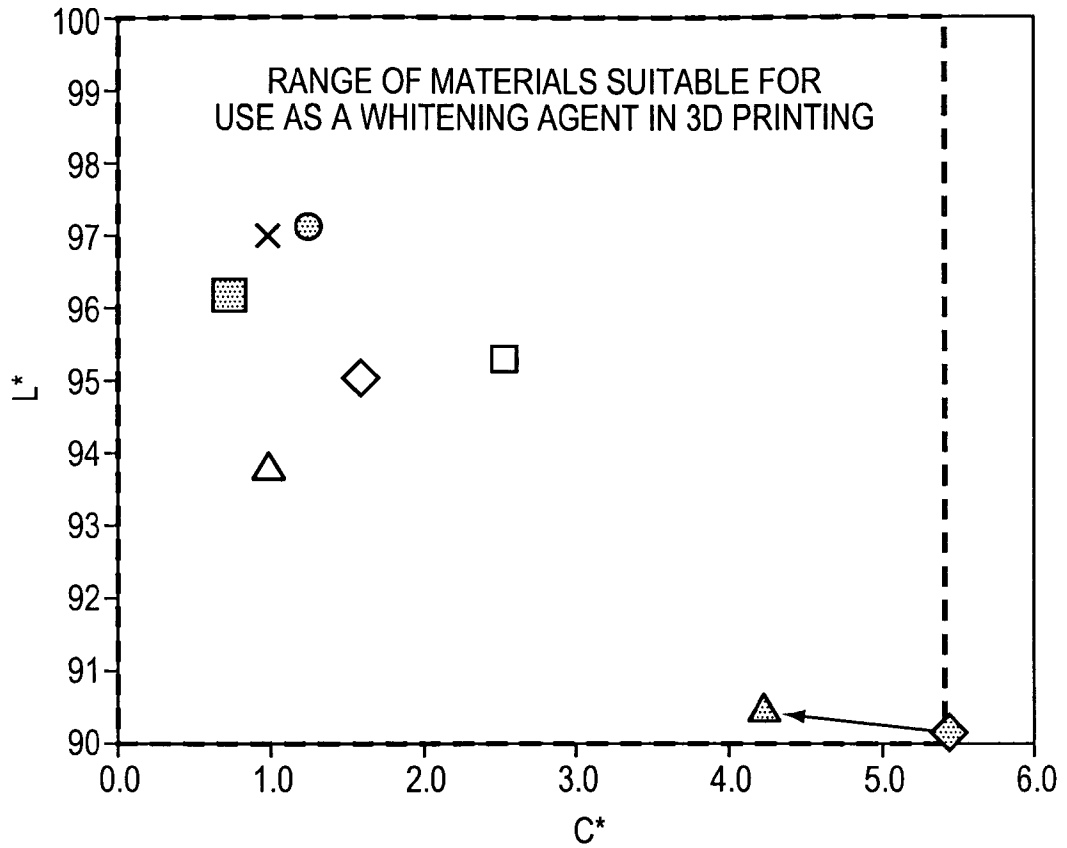

FIG. 4

3/21

L* - C* DATA OF VARIOUS WHITENERS FOR 3D PRINTING



- ◆ COMMERCIAL PLASTER
- POLYVINYL ALCOHOL
- △ POTATO STARCH
- ▒ MONOCALCIUM PHOSPHATE
- × S60HS GLASS BUBBLES
- TITANIA
- ▲ EXPERIMENTAL POWDER
- ◇ ZINC OXIDE

FIG. 5

4/21

(1) INITIATION

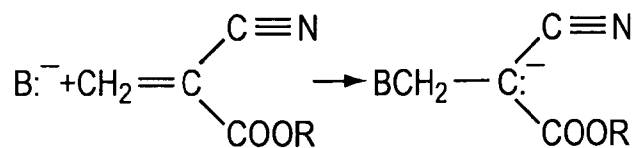

(2) PROPAGATION

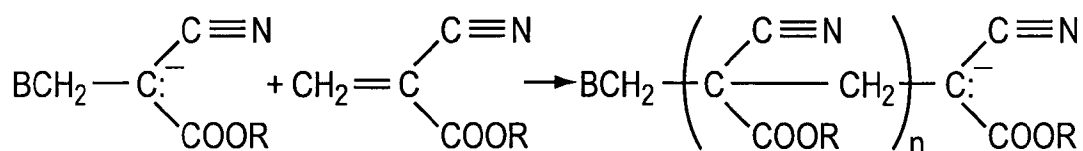

(3) TERMINATION

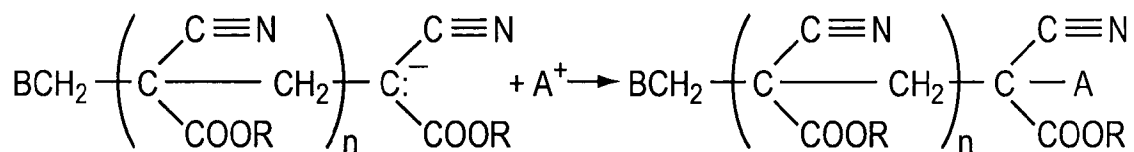

FIG. 6

5/21

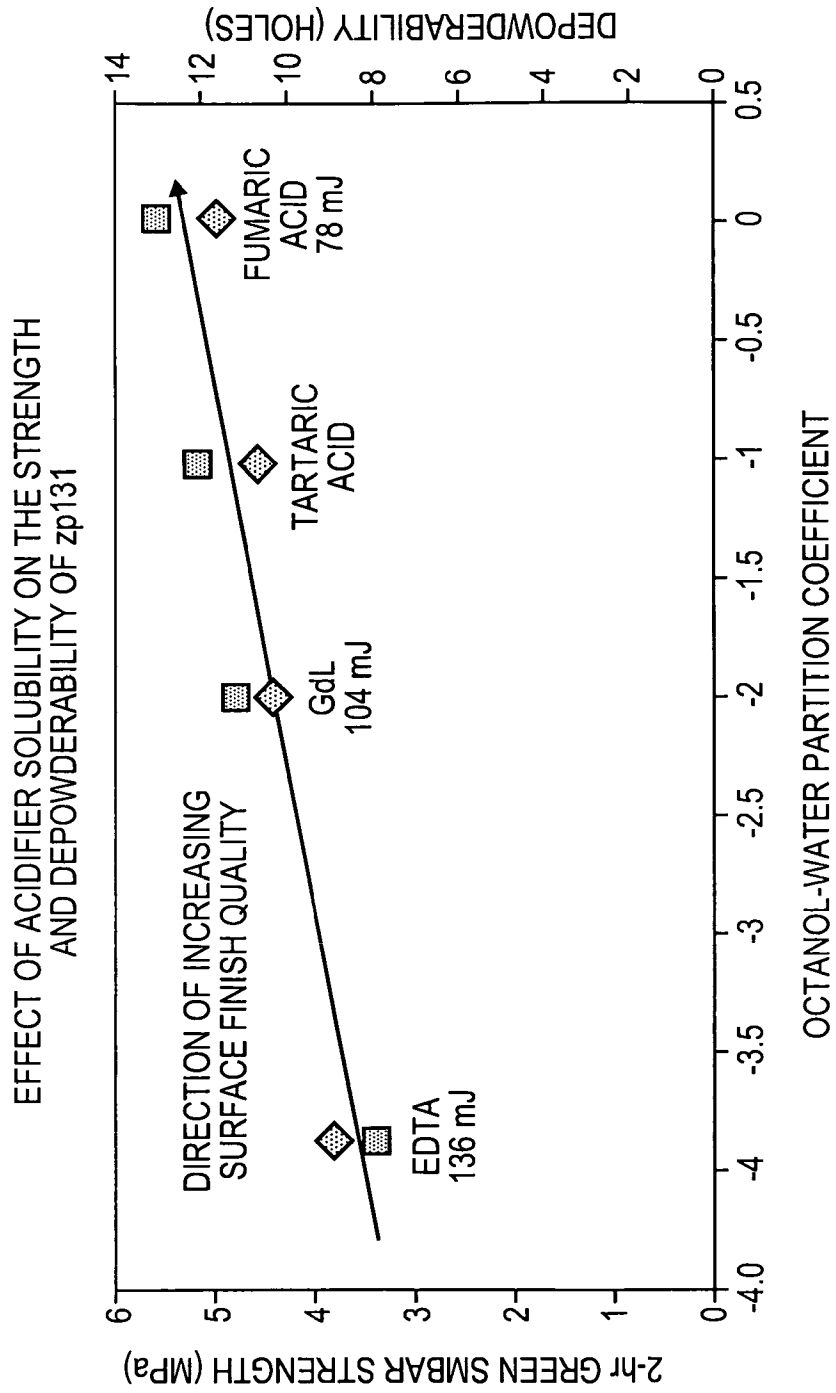

FIG. 7

6/21

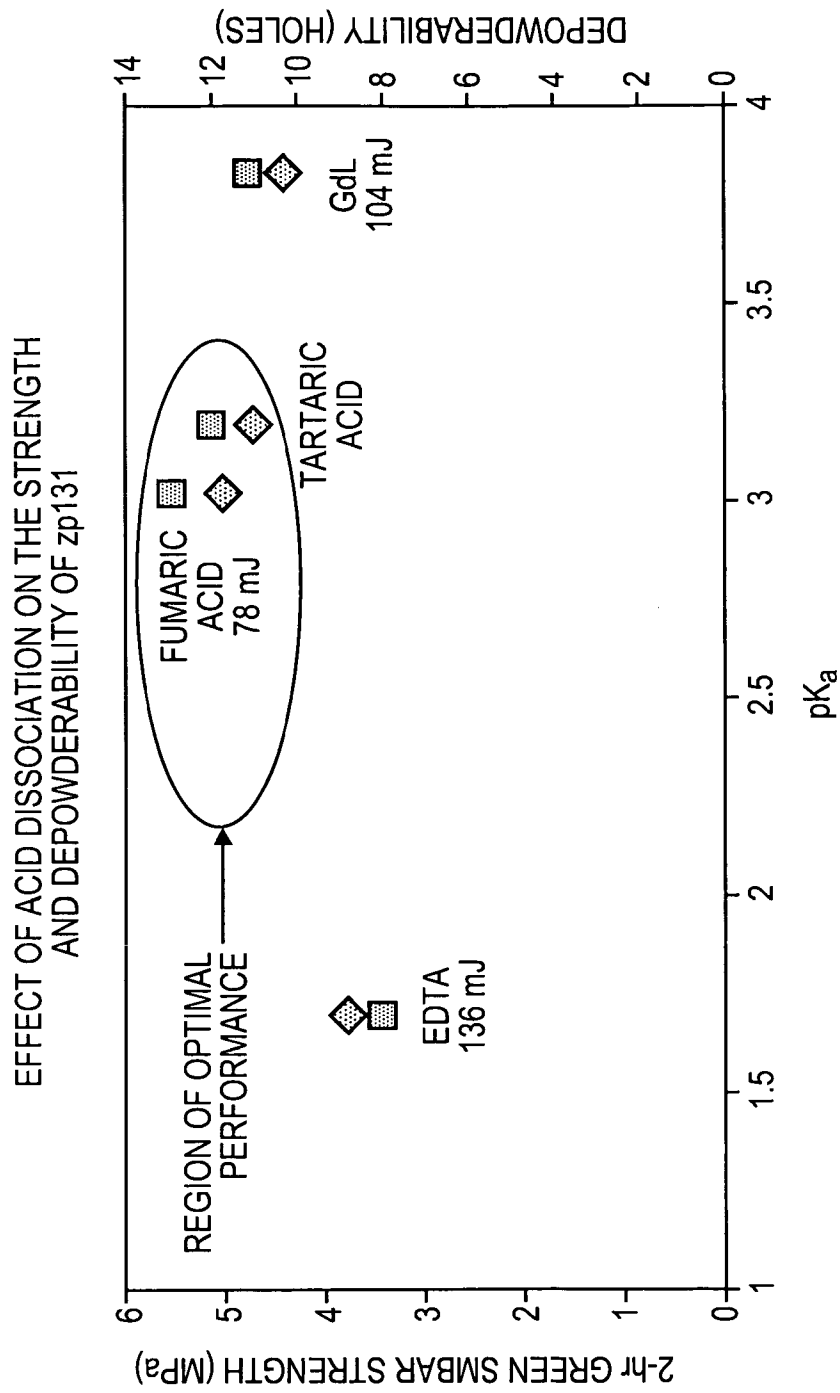

FIG. 8

7/21

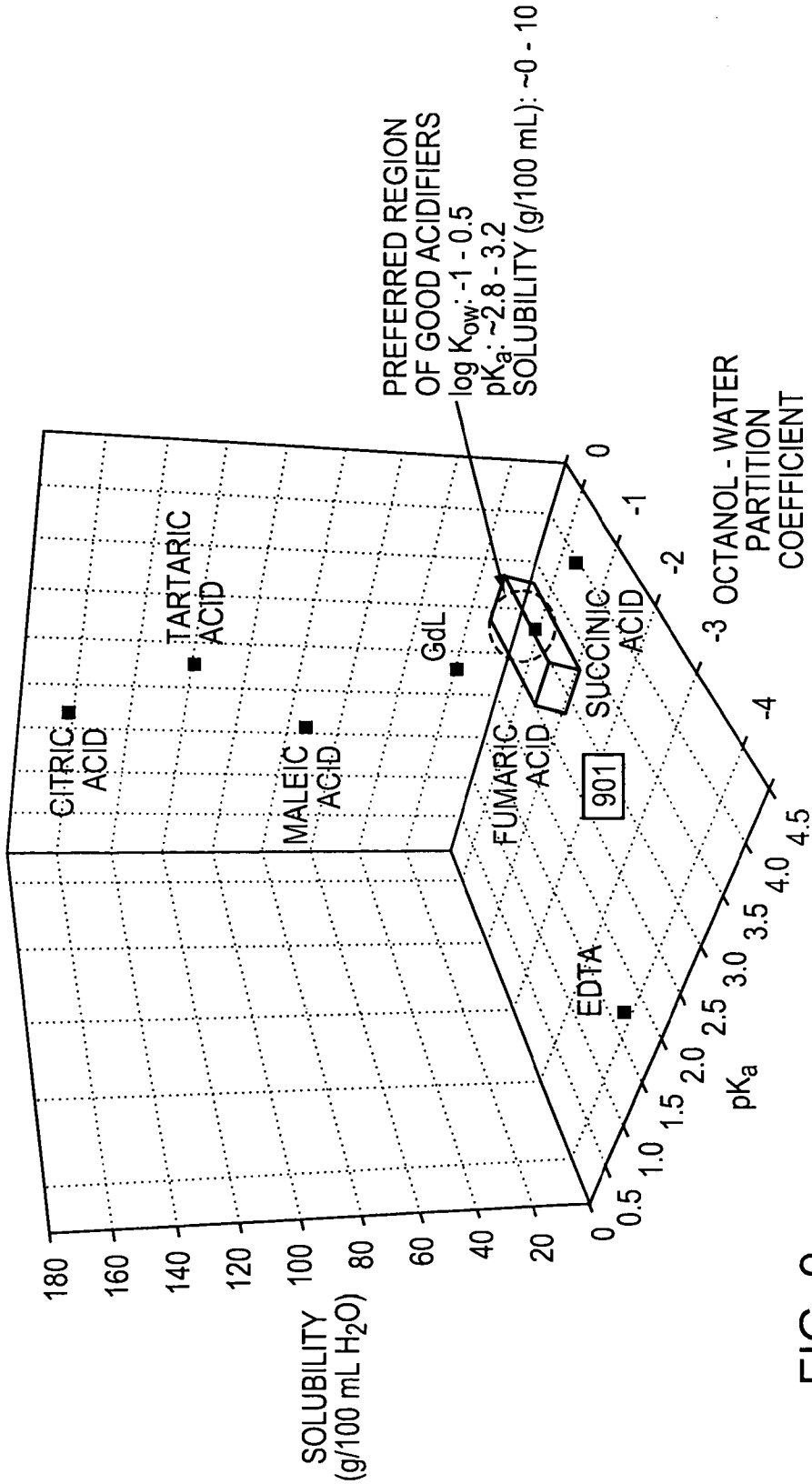

FIG. 9

8/21

EFFECT OF TARTARIC ACID CONTENT IN zp130 ON THE CYANOACRYLATE
INFILTRATED STRENGTH OF ASTM D790 BARS
BARS DRIED FOR 24-HRS AT 100F, MEASURED 1-HOUR AFTER INFILTRATION

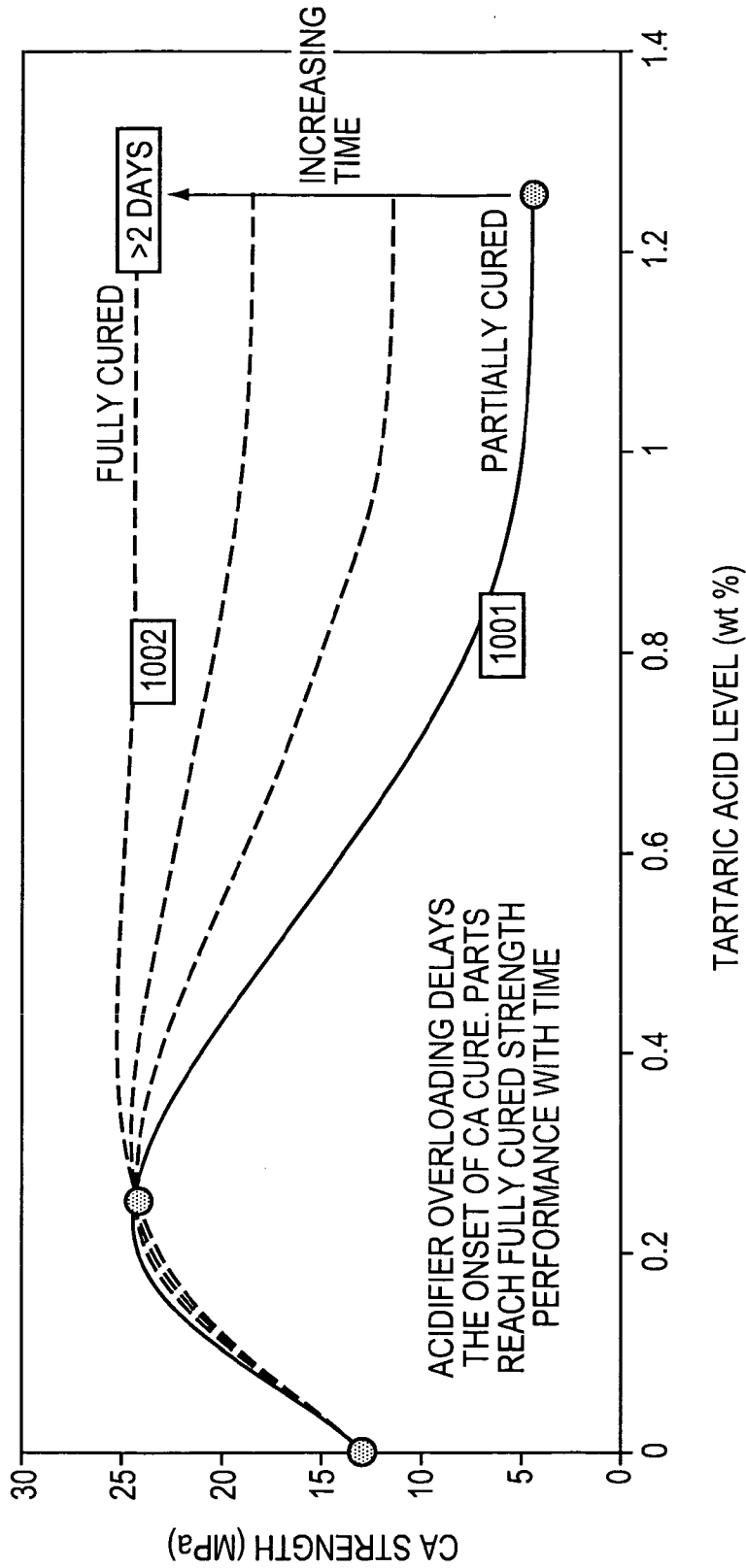

FIG. 10

9/21

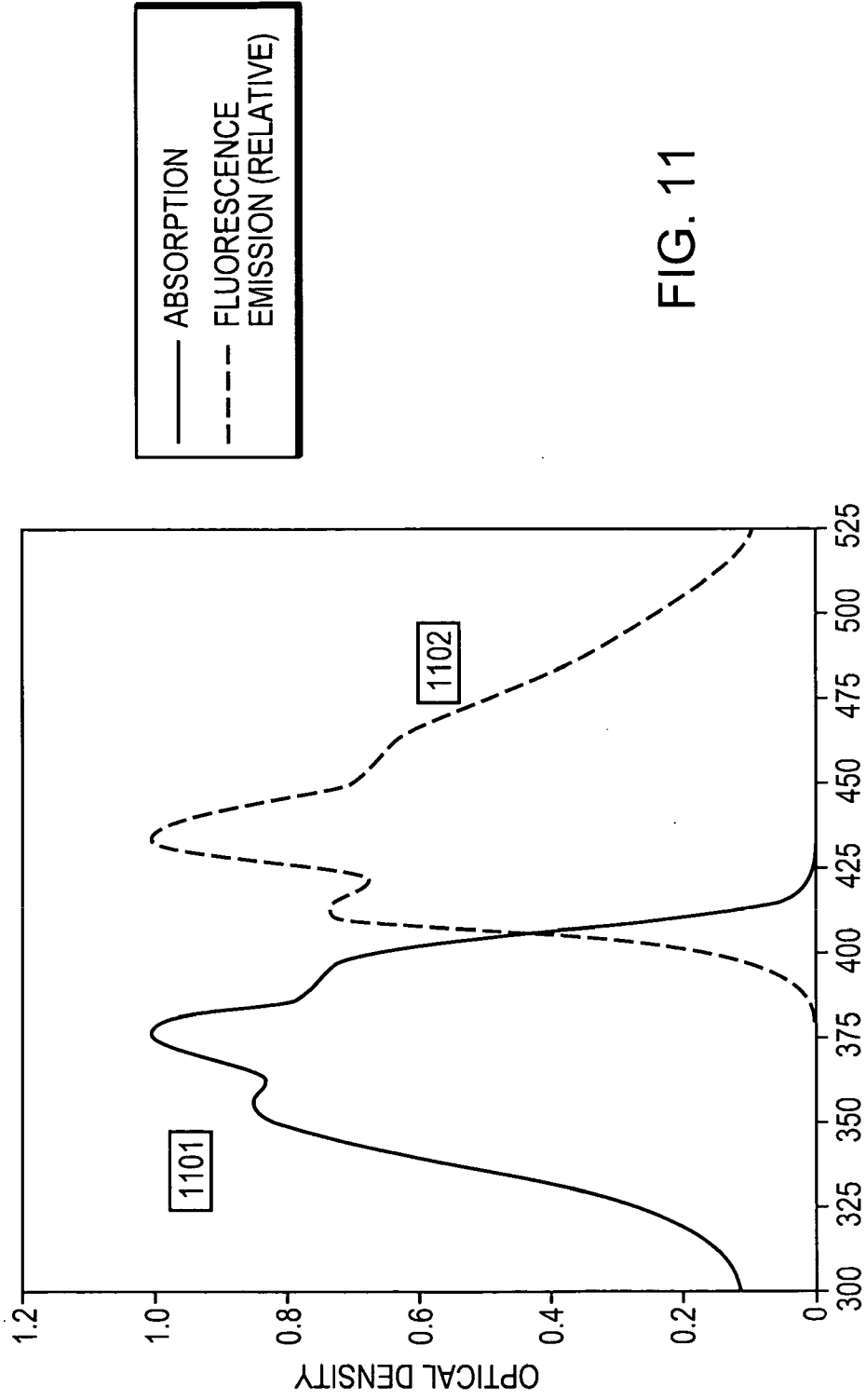

FIG. 11

10/21

EFFECT OF UVITEX RSB CONCENTRATION IN AN AQUEOUS FLUID ON THE SPECTRAL REFLECTANCE OF A WHITE PLASTER 3D PRINTED ARTICLE

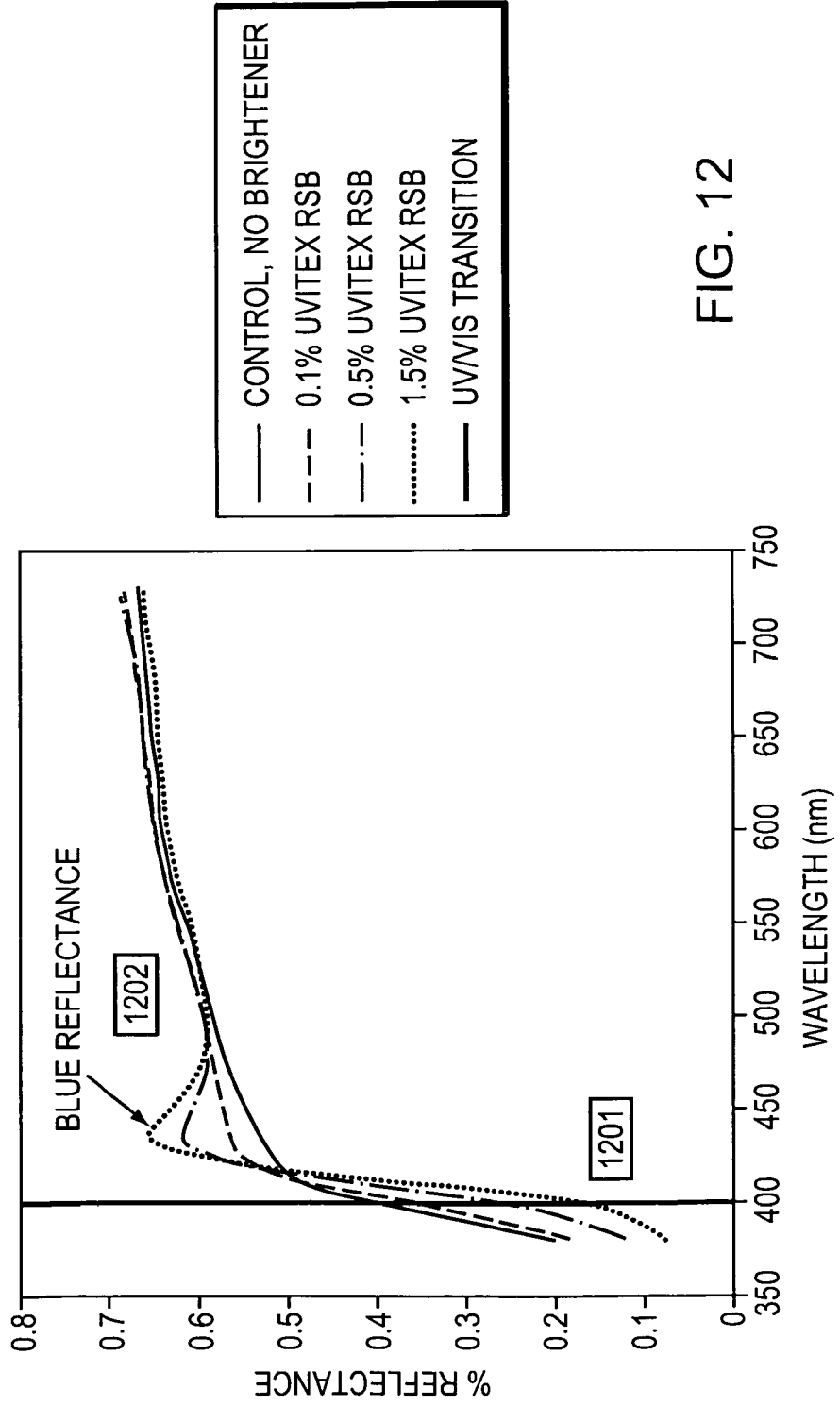

FIG. 12

11/21

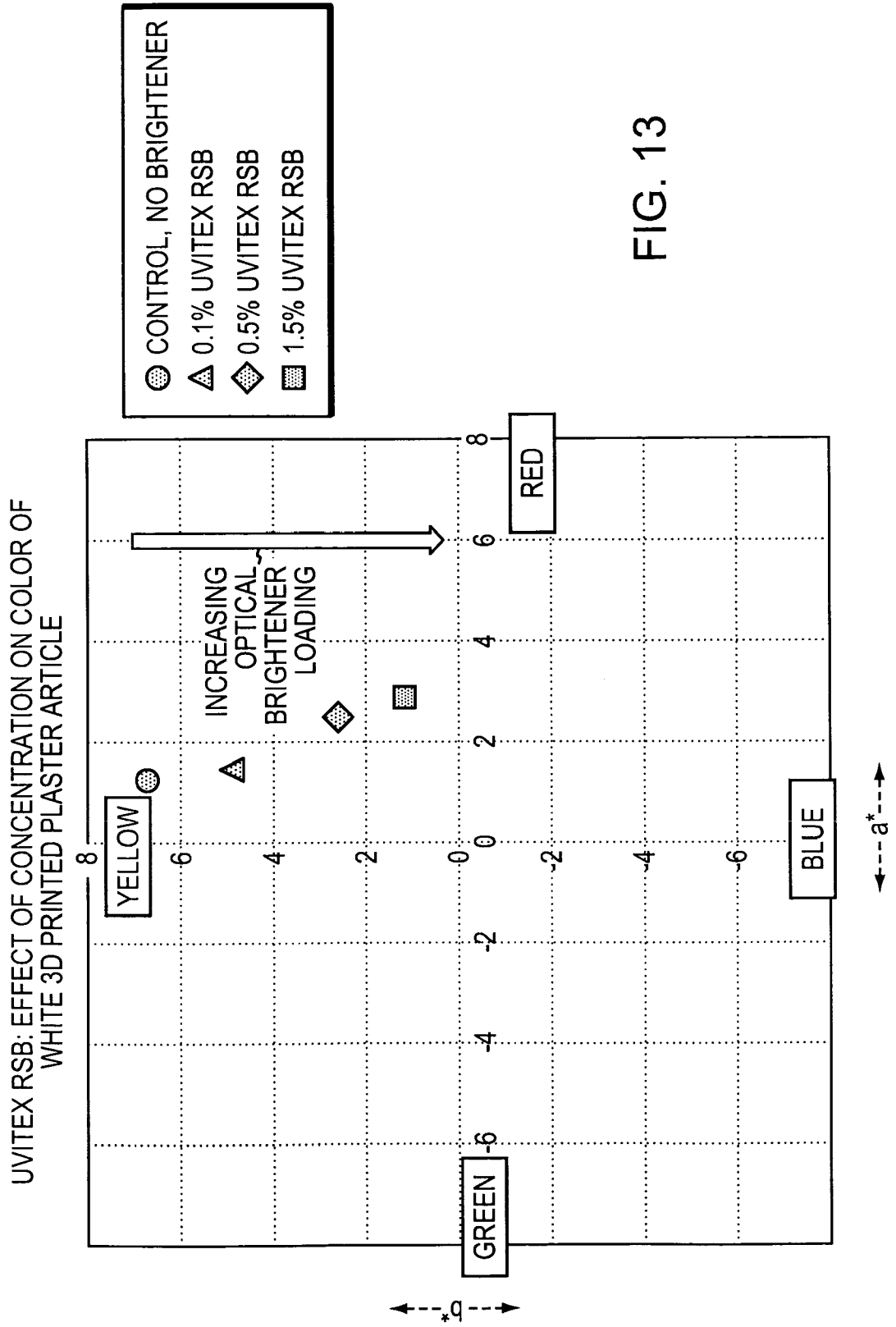
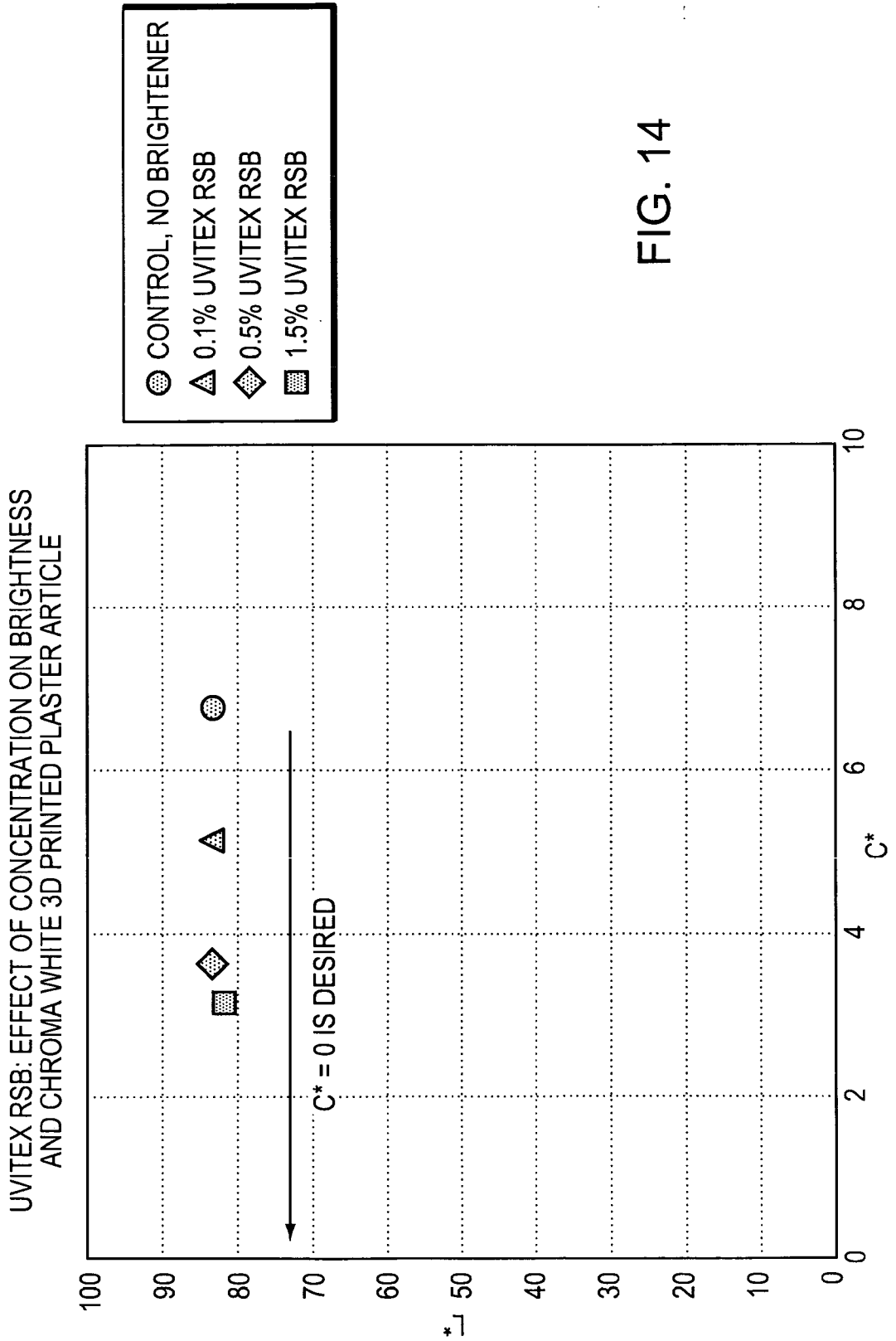

FIG. 13

12/21



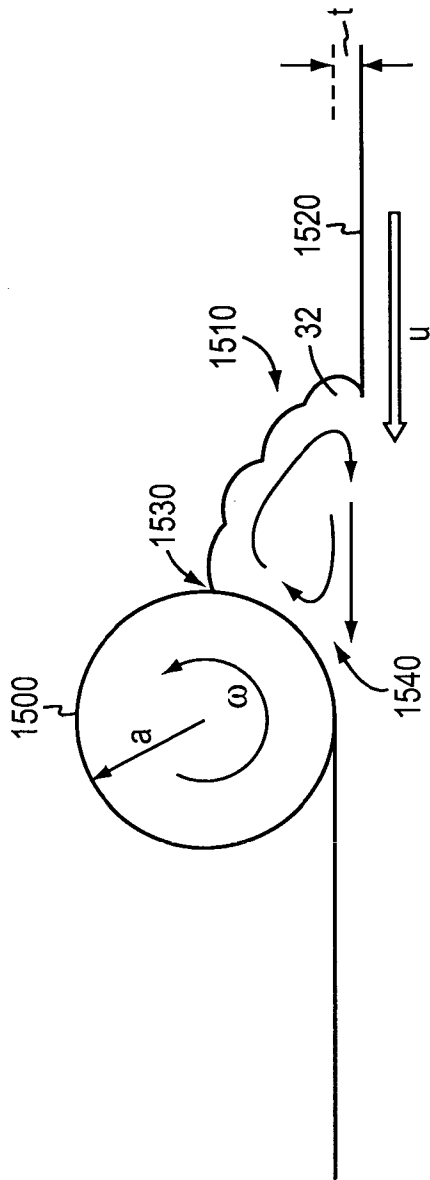

FIG. 15

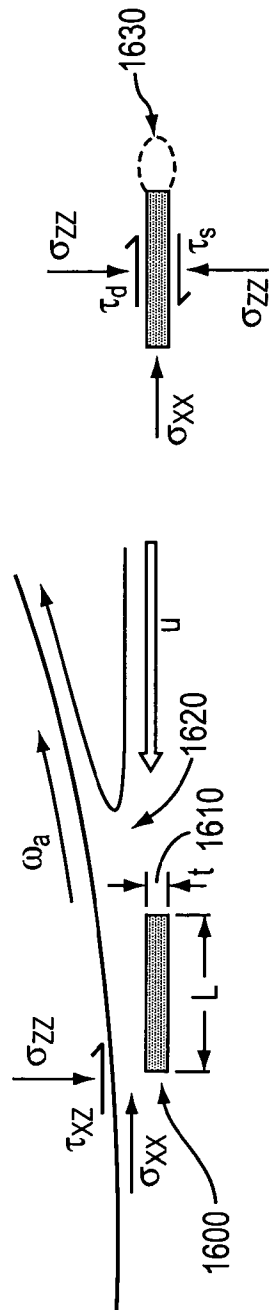

FIG. 16B

FIG. 16A

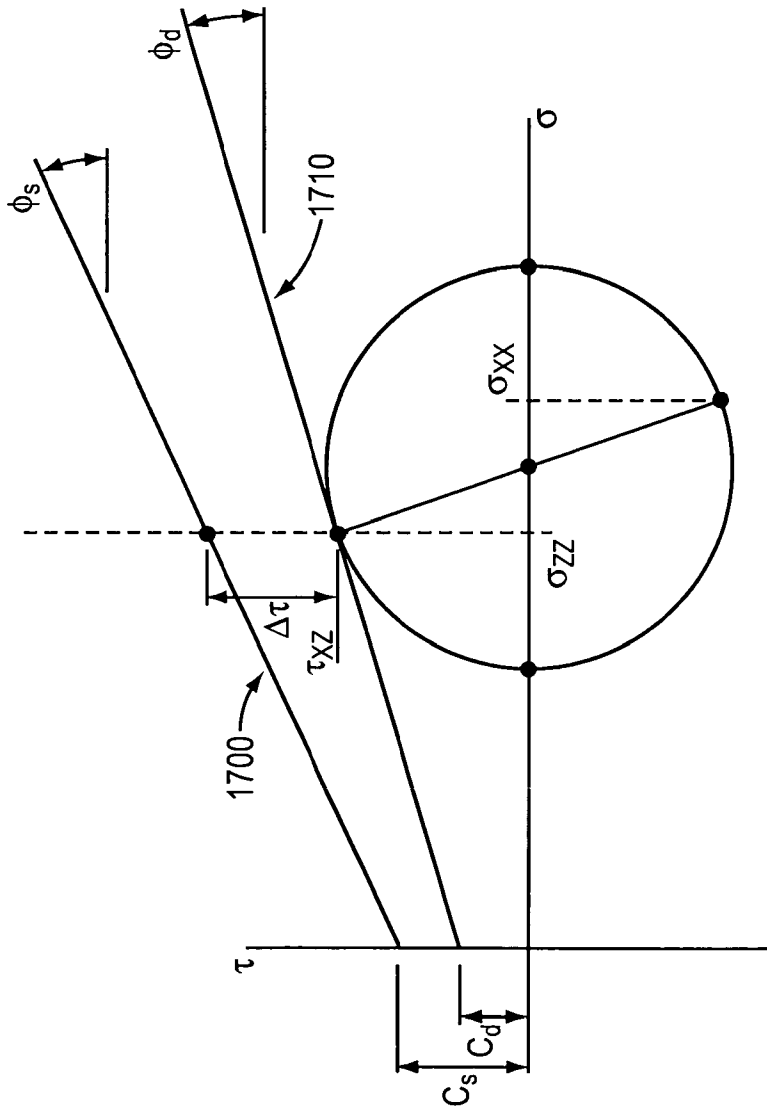

FIG. 17

16/21

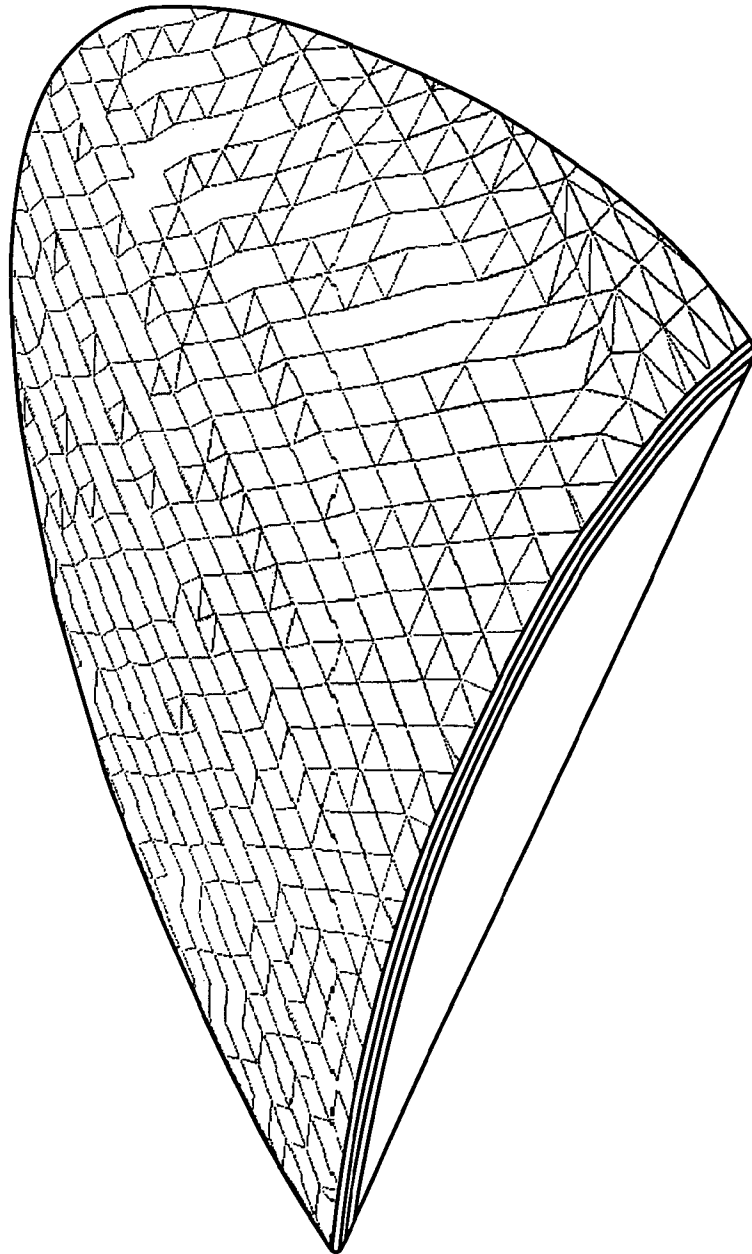

FIG. 18A

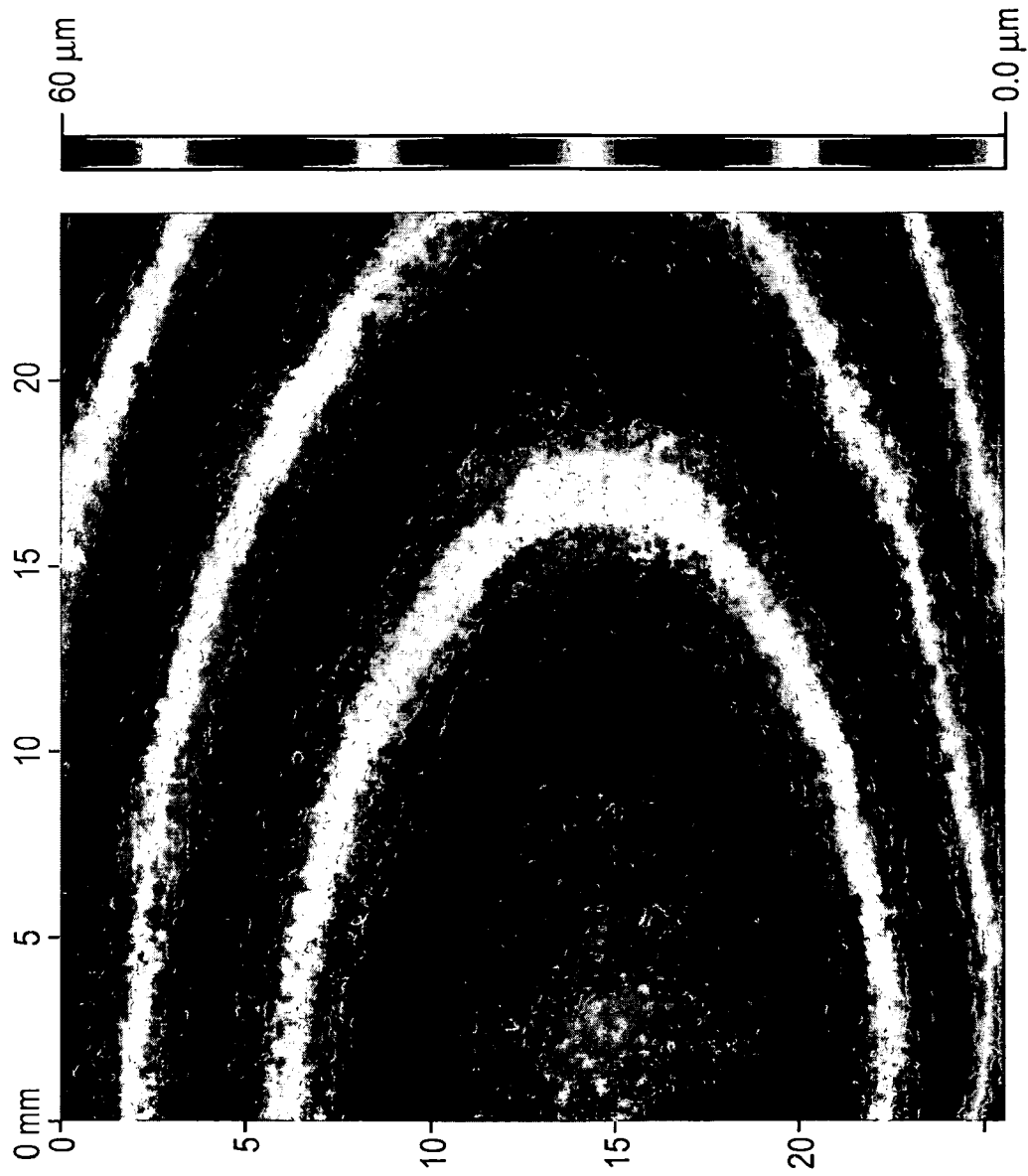

FIG. 18B

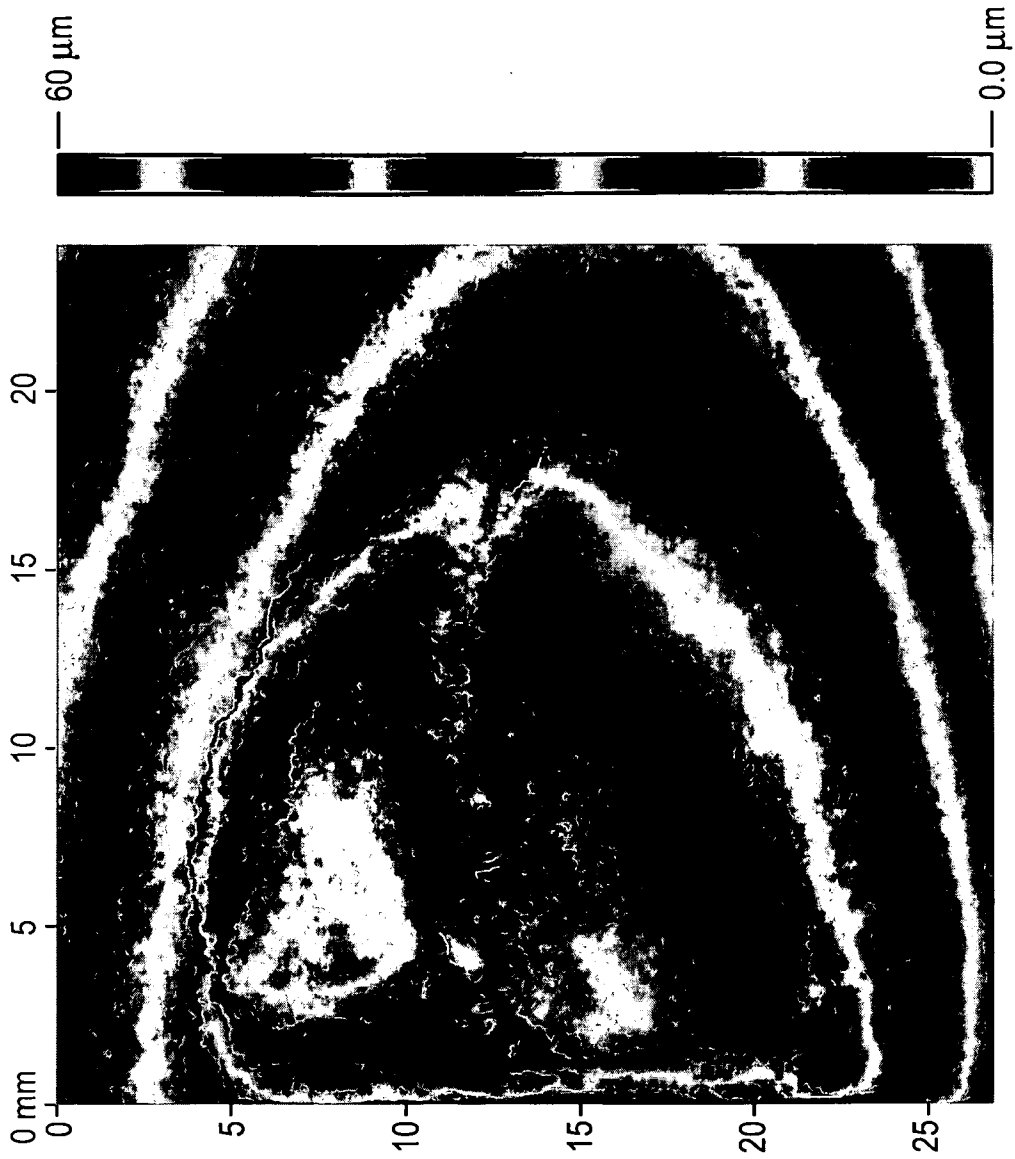

FIG. 18C

19/21

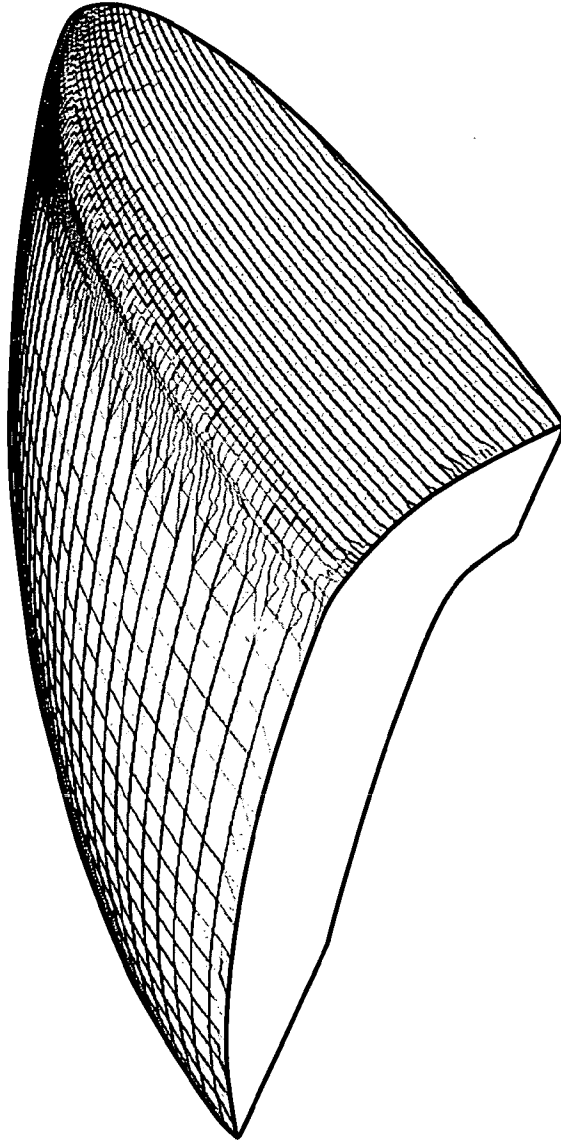

FIG. 19A

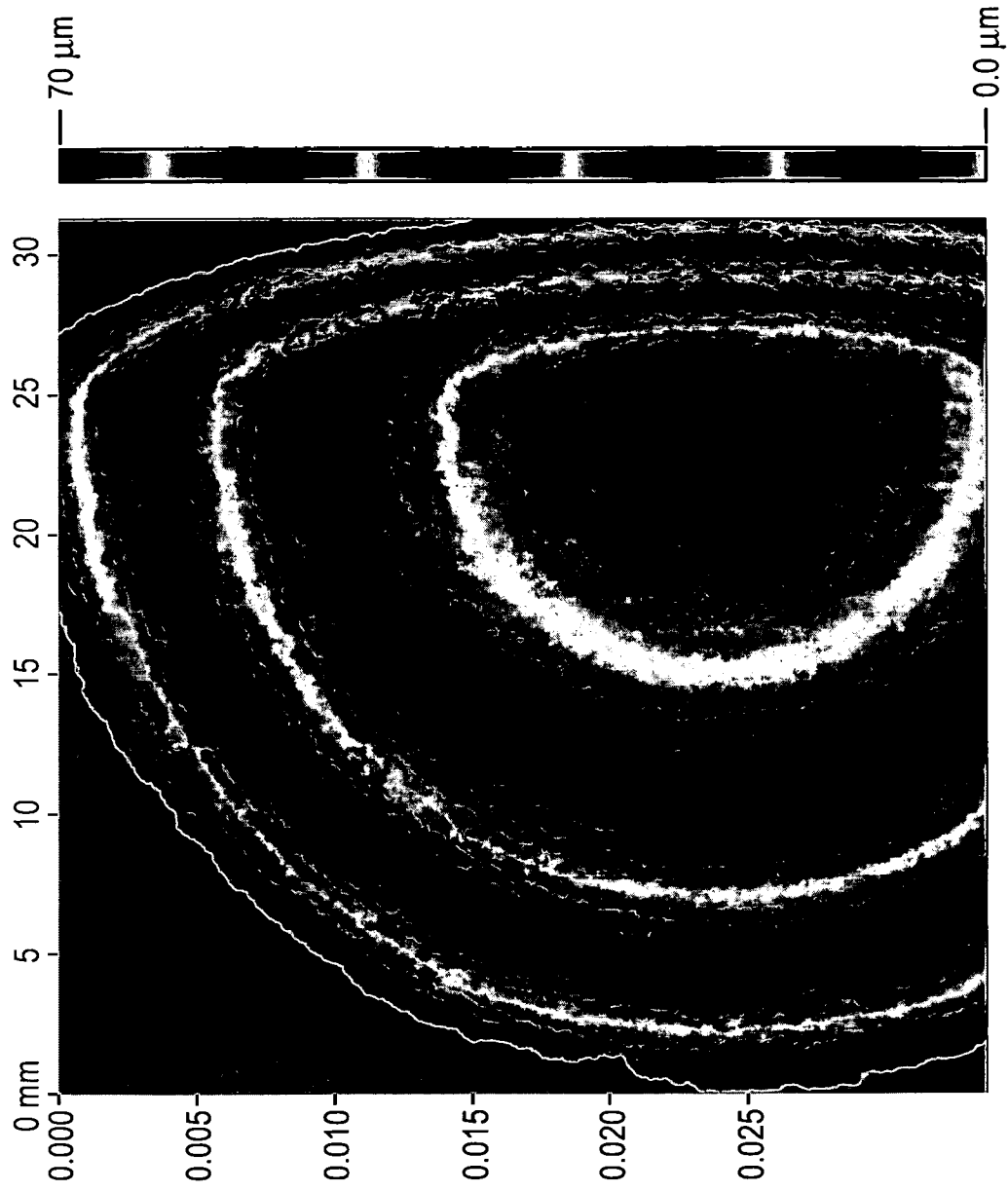

FIG. 19B

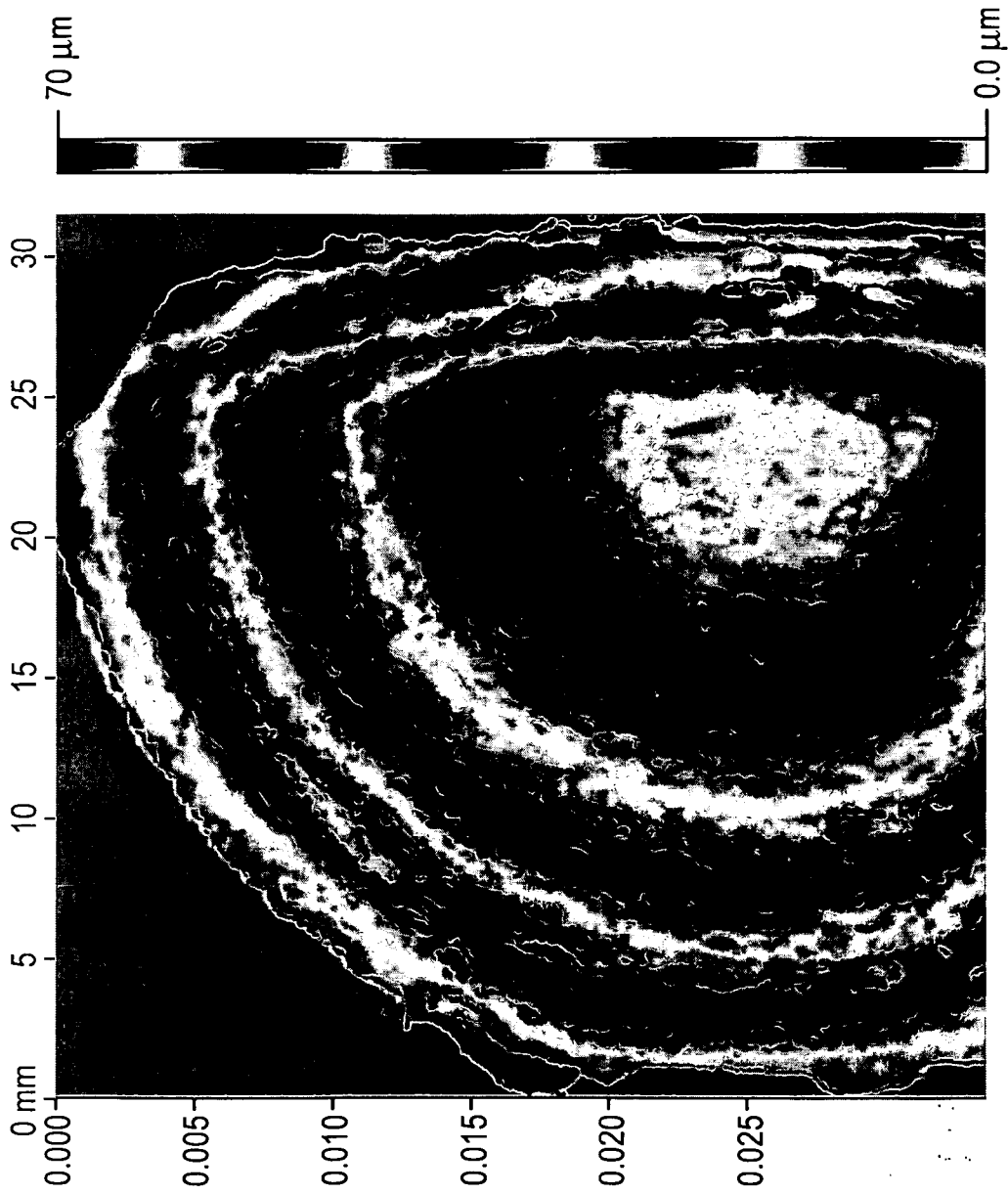

FIG. 19C

INTERNATIONAL SEARCH REPORT

International application No

PCT/US2008/000366

C(Continuation). DOCUMENTS CONSIDERED TO BE RELEVANT		
Category*	Citation of document, with indication, where appropriate, of the relevant passages	Relevant to claim No.
Y	WO 2005/023524 A (CORP Z [US]; BREDT JAMES F [US]; WILLIAMS DEREK X [US]; CLARK SARAH L) 17 March 2005 (2005-03-17) column 1, line 60 - line 65 column 6, line 29 - line 32 -----	18-25
Y	EP 1 498 277 A (HEWLETT PACKARD DEVELOPMENT CO [US]) 19 January 2005 (2005-01-19) paragraphs [0001], [0050] -----	18-25

INTERNATIONAL SEARCH REPORT

Information on patent family members

International application No

PCT/US2008/000366

Patent document cited in search report		Publication date	Patent family member(s)	Publication date
EP 1623816	A	08-02-2006	NONE	
US 5677107	A	14-10-1997	NONE	
WO 2005023524	A	17-03-2005	NONE	
EP 1498277	A	19-01-2005	JP 2005035299 A US 2005014005 A1	10-02-2005 20-01-2005