

(19) World Intellectual Property
Organization
International Bureau



(43) International Publication Date
29 December 2005 (29.12.2005)

PCT

(10) International Publication Number
WO 2005/123554 A1

- (51) International Patent Classification⁷: **B65G 47/91**, E. [US/US]; 2057 Spring Gulch Drive, Lyons, CO 80540 (US).
57/30
- (21) International Application Number: PCT/NL2005/000447
- (22) International Filing Date: 20 June 2005 (20.06.2005)
- (25) Filing Language: English
- (26) Publication Language: English
- (30) Priority Data: 10/869,927 18 June 2004 (18.06.2004) US
- (71) Applicant (for all designated States except US): **BLUEPRINT AUTOMATION B.V.** [NL/NL]; Oostzee 26, NL-3446 CH Woerden (NL).
- (72) Inventor; and
- (75) Inventor/Applicant (for US only): **RENOUX, Gerald**.
- (74) Agent: **VAN WESTENBRUGGE, Andries**; Nederlandsch Octrooibureau, P.O. Box 29720, NL-2502 LS The Hague (NL).
- (81) Designated States (unless otherwise indicated, for every kind of national protection available): AE, AG, AL, AM, AT, AU, AZ, BA, BB, BG, BR, BW, BY, BZ, CA, CH, CN, CO, CR, CU, CZ, DE, DK, DM, DZ, EC, EE, EG, ES, FI, GB, GD, GE, GH, GM, HR, HU, ID, IL, IN, IS, JP, KE, KG, KM, KP, KR, KZ, LC, LK, LR, LS, LT, LU, LV, MA, MD, MG, MK, MN, MW, MX, MZ, NA, NG, NI, NO, NZ, OM, PG, PH, PL, PT, RO, RU, SC, SD, SE, SG, SK, SL, SM, SY, TJ, TM, TN, TR, TT, TZ, UA, UG, US, UZ, VC, VN, YU, ZA, ZM, ZW.
- (84) Designated States (unless otherwise indicated, for every kind of regional protection available): ARIPO (BW, GH, GM, KE, LS, MW, MZ, NA, SD, SL, SZ, TZ, UG, ZM,

[Continued on next page]

(54) Title: SUCTION HEAD

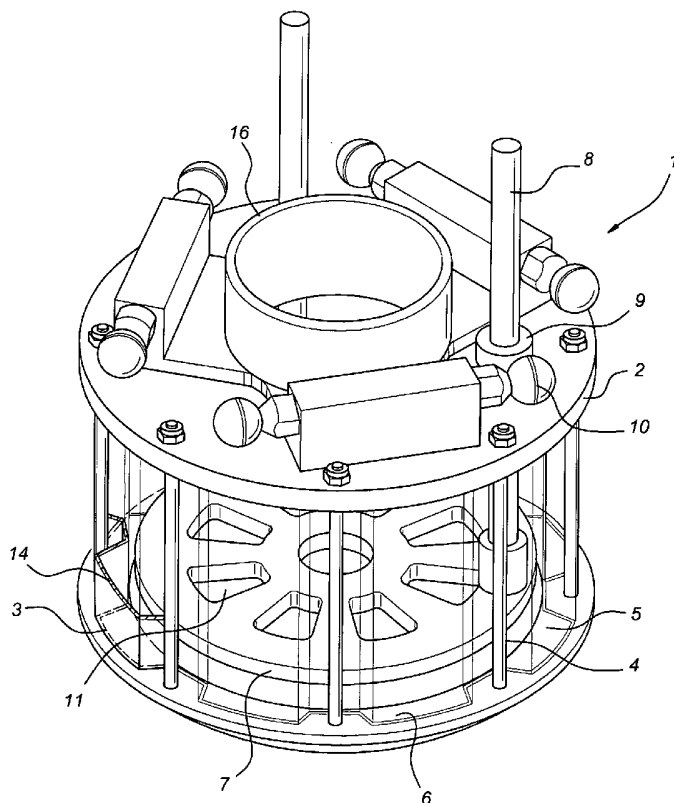

(57) Abstract: Suction head (1) and method for picking articles (20). The suction head comprises a sleeve-like (14) body having a connection (16) to an under pressure source at one end and an opening for picking up particles (20) at the other end thereof. Along side the sleeve channels (5) are provided being connected to the under pressure source an opening near the lower end (3) of the sleeve. The lower end (3) of the sleeve (14) is delimited by a circumferential edge so that the article is picked with only a small clearance between the article and the inner circumference of the circumferential ring (6). A platen (7) is provided against which the article is placed. This platen can be moved relative to the sleeve.

WO 2005/123554 A1



ZW), Eurasian (AM, AZ, BY, KG, KZ, MD, RU, TJ, TM),
European (AT, BE, BG, CH, CY, CZ, DE, DK, EE, ES, FI,
FR, GB, GR, HU, IE, IS, IT, LT, LU, MC, NL, PL, PT, RO,
SE, SI, SK, TR), OAPI (BF, BJ, CF, CG, CI, CM, GA, GN,
GQ, GW, ML, MR, NE, SN, TD, TG).

For two-letter codes and other abbreviations, refer to the "Guidance Notes on Codes and Abbreviations" appearing at the beginning of each regular issue of the PCT Gazette.

Published:

— *with international search report*

Title: Suction head.

The subject invention relates to a suction head for gripping a number of articles according to the preamble of claim 1. Such a suction head can be used to pick or grip a
5 number of waver-like articles such as food stuff products. An example of such a suction head is disclosed in US 6,554,336 A. This suction head is used for picking up articles and comprises a sleeve having an upper plate to which a platen is mounted through spacers. This platen is in a fixed position relative to the upper plate and sleeve.

10 The invention aims to provide a suction head to smoothly grip more than one article in order to provide a stack of articles.

This aim is realized in a suction head for gripping a number of articles having the features of claim 1.

15

To control the movement of the articles within the suction head and to prevent tilting of disc-shaped articles in the suction head according to the invention the platen is displaceable in the sleeve. In the starting position preferably the platen is positioned somewhat above the upper surface of the circumferential ring. The article which is
20 picked up will then be suctioned through the opening of the circumferential ring and be positioned against the platen. Before a second article is picked up the platen can be moved one position higher providing space for a second article. In this way a controlled stacking of articles within the suction head can be realized.

25 However, such a displaceable provision of said platen also allows controlled discharge of the suction head. If the suction head is filled as required with articles and displaced to a discharging position except from releasing the vacuum, also the platen can be pushed outwardly such that the articles are discharged in a controlled way in for example a package for food stuff.

30

According to a preferred embodiment of the invention the first end of said sleeve is provided with a circumferential ring extending between said outer and inner

circumferential shape of said sleeve and defining an inner circumference corresponding substantially to the outer circumference of said platen.

According to this embodiment a circumferential ring or lower plate is provided at the
5 bottom of the sleeve. If an article is suctioned after passing the circumferential ring the
flow of air will be between the top of the circumferential ring and the lower part of the
article. In this way the article will float at a slight distance above the circumferential
ring. After a further second article is picked up the first article will be moved one
10 position in upward direction whilst the second article with the first article resting
thereon will be in the same position as the original position of the first article i.e. at
some distance above the upper surface of the circumferential ring. In this way high
speed upward movement of the articles after entering the suction head is prevented as
well as damage as consequence thereof.

15 Basically the platen can have a larger outer circumference than the inner circumference
of the circumferential ring. However, according to a preferred embodiment of the
invention there is some clearance between the outer circumference of the platen and the
inner circumference of the circumferential ring such that the platen can move in or even
through the circumferential ring.

20

According to a further embodiment of the invention the sleeve is provided at its inner
circumference with guiding channels which function on the other hand to connect the
under pressure from an under pressure source at the top of the sleeve to the lower end
of the sleeve. It is possible to provide suction both at the lower end of the sleeve and in
25 the area wherein the articles are stacked. Such guiding channels can be obtained by
corrugating the sleeve.

Preferably the platen is shaped to be positioned adjacent to the channels described
above.

30

The invention also relates to a method for picking a number of articles and forming a
stack, comprising positioning a suction head above a first article to be picked, applying
under pressure in said suction head and moving said first article by said under pressure

against an abutment platen provided in said suction head, picking a second article by said suction head and moving said second article against said first article to form a stack, wherein before picking said second article said platen together with said first article is further moved into said suction head.

5

The invention will be further elucidated referring to preferred embodiments of the invention shown in the drawings, wherein:

Fig. 1 shows in perspective view a first embodiment of the suction head according to
10 the invention;

Fig. 2 shows the suction head according to fig. 1 of the gripping articles.

Fig. 3 schematically shows the air flow in the gripping head according to fig.1 and 2;
15 and

Fig. 4 shows an alternative of the suction head according to the invention.

In fig. 1 the suction head according to the invention is generally referred to by 1. The
20 suction head comprises a corrugated sleeve 14 having a lower edge 3. An upper plate 2 is provided on top of the sleeve 14. A lower plate or circumferential ring 6 is connected to the lower edge 3 and protrudes perpendicular from the sleeve 14.

The upper plate 2 and circumferential 6 are connected through spacer rods 4. Channels
25 5 are defined by the corrugations of the sleeve and provide flow communication between the connection 16 coupled to a source of under pressure and the lower edge 3.

The upper plate 2 is provided with guiding bushes 9 for guiding a slide bar 8 connected to platen 7. However, it should be noted that platen 7 can be guided/operated in any other way from upper plate 2.

30 15 indicates the longitudinal axis of the sleeve 14. Openings 11 can be provided in the platen. Channels 5 provide flow connection between the inlet opening of the circumferential ring or lower plate and connection 16. The suction head is connected to an arm not shown to coupling balls 10. Other connecting means can be used.

This device functions as follows. Through an arm not shown the suction head 1 is positioned above a surface from which the articles such as food stuff and more particular frozen pancakes, have to be picked. The platen 7 is in a low position and there is a continuous flow of air to the under pressure source. As soon as the suction head is above an article to be picked it is lowered and the related article is moved through the lower plate 6 and contacts the lower surface of the platen 7. In this position the article is just above the lower plate 6. Because the main flow of air is from below the article through the corrugations the article will be in a semi-floating condition against the platen 7. Subsequently the suction head is indexed in upward direction.

If the next article to be gripped is found, the suction head is lowered and the platen 7 is moved one position in upward direction. The next second article is positioned in the original position of the first article. After three articles have been picked this way the position of fig. 2 is realized. After receiving an article the platen is indexed upwardly and the next article is taken away from the related surface. After the desired number of articles is formed the suction head is moved to a discharge position. After removal of the under pressure and possibly using over pressure and through downward movement of the platen, the stack of articles is conveyed to a further desired position.

In the room above the platen 7 there is some under pressure. This under pressure is transferred to the first article.

In fig. 4 a further embodiment of the invention is shown. The suction head is generally referred to by 21 and comprises an upper platen 22, lower edge 23 as well as separate air flow channels 25. However, these channels are closed all around and only function for guidance of the articles and fluid connection for under pressure. The lower plate has reference number 26 whilst platen 27 can be moved in upward and downward direction through actuating of a slide bar 28. The actuating mechanism for the slide bar is not shown.

30

The sleeve of the suction head is referred to by 34 whilst the axis of movement of the slide bar 28 has reference 35. 36 is the vacuum connection. In this embodiment there are openings 33 between the lower plate 26 and the channels or inner sleeve 32. In this

case if a group of articles is picked up the lowest article will pressurize the articles there above against the platen 27. The platen 27 is indexed upward as the articles are accumulated.

- 5 The device as described above allows for gripping a large number of articles such as wafer shaped articles having a size substantially corresponding to the size of the platen. The articles are gripped in a fast and gentle way which allows for a high throughput without the risk of damaging the articles.

- 10 After reading the above the person skilled in the art will immediately be able to effect other embodiments which are obvious after the above and within the range of the appended claims.

Claims

1. Suction head (1, 21) for gripping a number of articles (20) comprising a sleeve (14, 34) having a longitudinal axis (15, 35), a first end (3, 23) for receiving said articles and
5 a second end (2, 22) having a connection (16, 36) to an under pressure source and connections (10) for connecting to a manipulating arm, wherein an abutment platen (7, 27) is provided between said first and said second end, said platen having an outer circumferential shape substantially smaller than the inner circumferential shape of said sleeve, characterized in that said platen is displaceable in said sleeve in the direction of
10 said longitudinal axis.
2. Suction head according to claim 1, wherein a clearance is provided between said platen and said circumferential ring.
- 15 3. Suction head according to one of the preceding claims, wherein the first end of said sleeve is provided with a circumferential ring (6, 26) extending between said outer and inner circumferential shape of said sleeve (14, 34) and defining an inner circumference corresponding substantially to the outer circumference of said platen.
- 20 4. Suction head according to claim 3, wherein said second end (2) comprises a guide bore (9) for receiving a bar (8) connected to said platen.
5. Suction head according to one of the preceding claims, wherein said sleeve (14, 34) is provided at its inner circumference with an under pressure channel (5, 25) being
25 connected to the under pressure source connection (16, 36) at one end and opening near said circumferential ring (6, 26) at the other end.
6. Suction head according to claim 5, wherein said under pressure connection (16, 36) is only connected to said channel.
- 30 7. Suction head according to claim 5 or 6, wherein the outer surface of said platen (7, 27) is adjacent to the inner surface of said channel.

8. Method for picking a number of articles (20) and forming a stack, comprising positioning a suction head above a first article to be picked, applying under pressure in said suction head and moving said first article by said under pressure against an abutment platen provided in said suction head, picking a second article by said suction
5 head and moving said second article against said first article to form a stack, wherein before picking said second article said platen together with said first article is further moved into said suction head.

9. Method according to claim 8, wherein after forming said stack, said stack is
10 discharged by releasing said under pressure and moving said platen together with said stack of articles outwardly from said suction head.

10. Method according to claim 8 or 9, wherein only said second article is subjected to said under pressure.

Fig 1

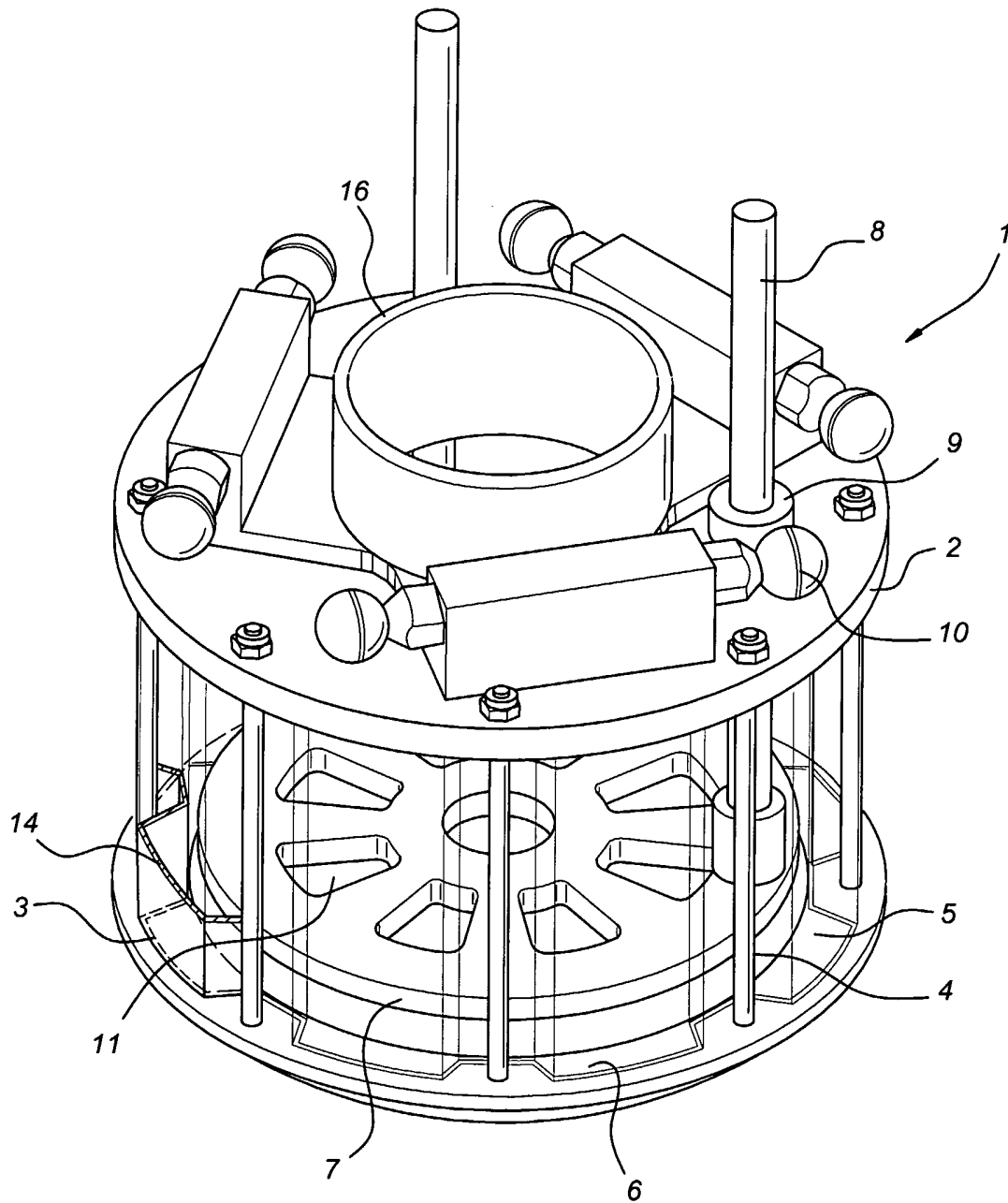
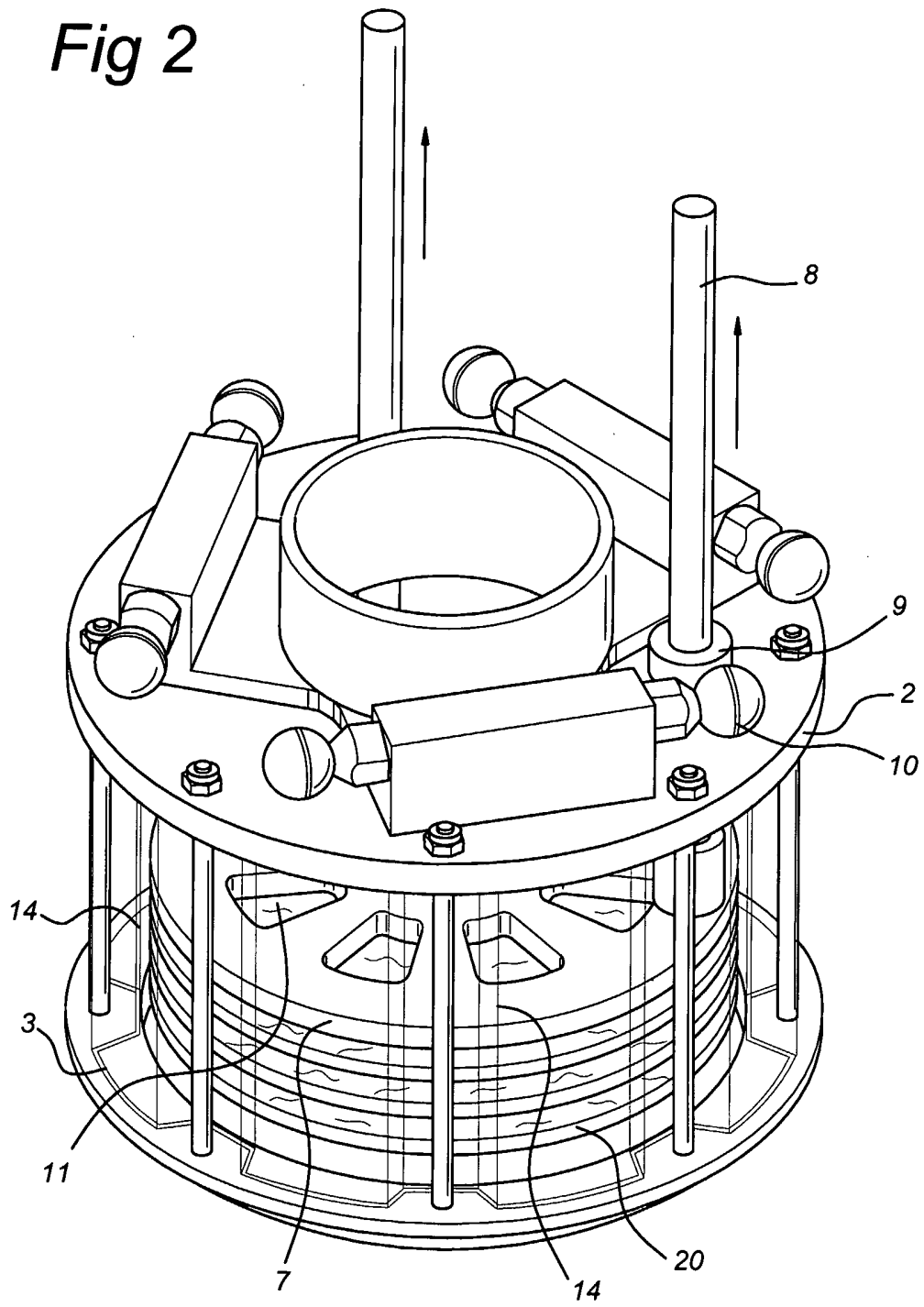

Fig 2



3/3

Fig 3

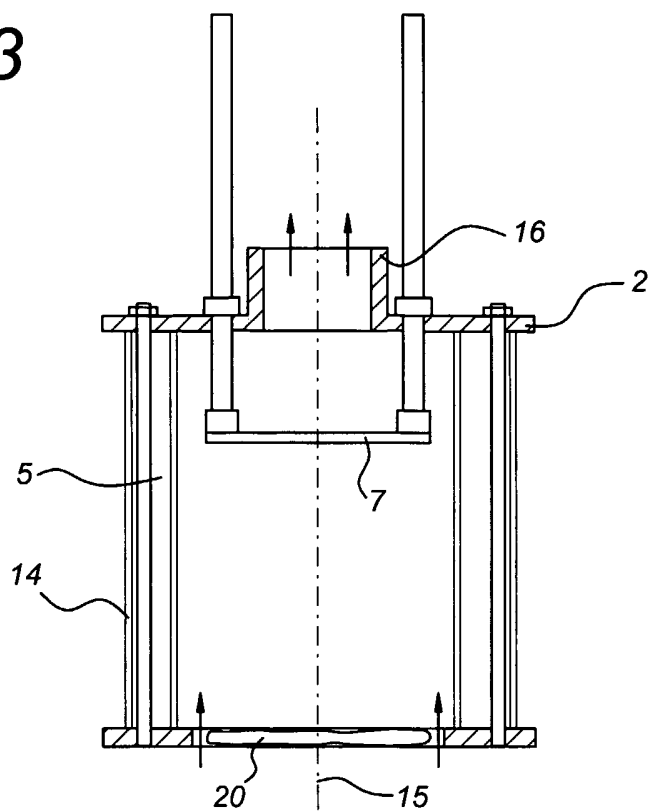
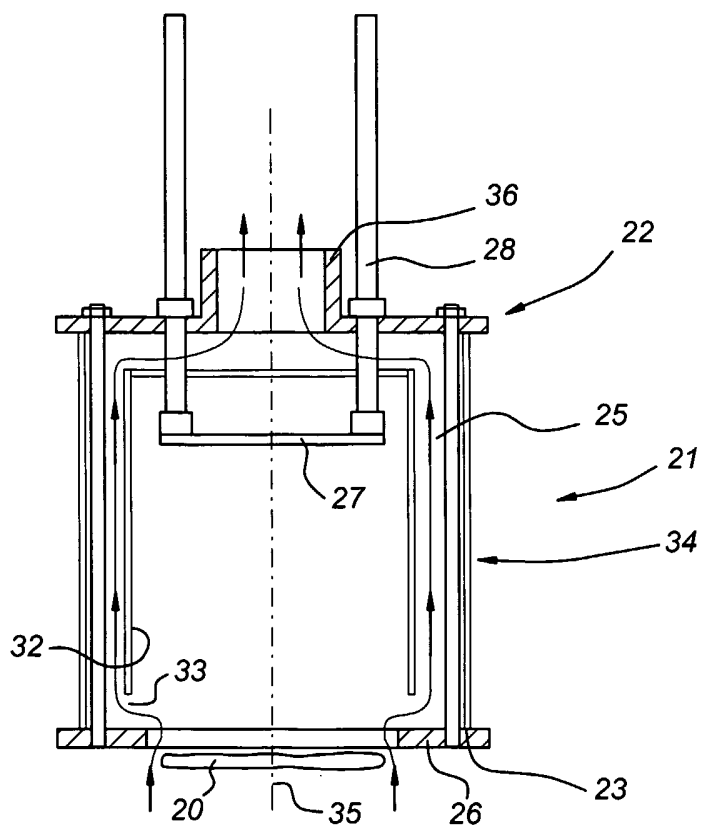

Fig 4



INTERNATIONAL SEARCH REPORT

Int. Patent Application No
PCT/NL2005/000447

A. CLASSIFICATION OF SUBJECT MATTER
IPC 7 B65G47/91 B65G57/30

According to International Patent Classification (IPC) or to both national classification and IPC

B. FIELDS SEARCHED

Minimum documentation searched (classification system followed by classification symbols)

IPC 7 B65G B25J B65B B65H B23P

Documentation searched other than minimum documentation to the extent that such documents are included in the fields searched

Electronic data base consulted during the international search (name of data base and, where practical, search terms used)

EPO-Internal, WPI Data

C. DOCUMENTS CONSIDERED TO BE RELEVANT

Category °	Citation of document, with indication, where appropriate, of the relevant passages	Relevant to claim No.
X	US 3 289 860 A (DEAN GEORGE A) 6 December 1966 (1966-12-06)	1-7
A	column 1, line 10 - line 12 column 3, line 1 - line 66 figures 1-5	8-10
A	----- US 6 554 336 B2 (HÜPPI EMIL) 29 April 2003 (2003-04-29) cited in the application the whole document -----	1,8

Further documents are listed in the continuation of box C.

Patent family members are listed in annex.

° Special categories of cited documents :

"A" document defining the general state of the art which is not considered to be of particular relevance

"E" earlier document but published on or after the international filing date

"L" document which may throw doubts on priority claim(s) or which is cited to establish the publication date of another citation or other special reason (as specified)

"O" document referring to an oral disclosure, use, exhibition or other means

"P" document published prior to the international filing date but later than the priority date claimed

"T" later document published after the international filing date or priority date and not in conflict with the application but cited to understand the principle or theory underlying the invention

"X" document of particular relevance; the claimed invention cannot be considered novel or cannot be considered to involve an inventive step when the document is taken alone

"Y" document of particular relevance; the claimed invention cannot be considered to involve an inventive step when the document is combined with one or more other such documents, such combination being obvious to a person skilled in the art.

"&" document member of the same patent family

Date of the actual completion of the international search

13 September 2005

Date of mailing of the international search report

21/09/2005

Name and mailing address of the ISA

European Patent Office, P.B. 5818 Patentlaan 2
NL - 2280 HV Rijswijk
Tel. (+31-70) 340-2040, Tx. 31 651 epo nl,
Fax: (+31-70) 340-3016

Authorized officer

Papatheofrastou, M

INTERNATIONAL SEARCH REPORT

Information on patent family members

International Application No

PCT/NL2005/000447

Patent document cited in search report	Publication date	Patent family member(s)	Publication date	
US 3289860	A	06-12-1966	BE 665145 A	01-10-1965
			DE 1293995 B	30-04-1969
			FR 1436431 A	04-07-1966
			GB 1114862 A	22-05-1968
			NL 6507315 A	10-12-1965

US 6554336	B2	29-04-2003	EP 1162163 A1	12-12-2001
			JP 2002066974 A	05-03-2002
			US 2001050488 A1	13-12-2001
