

E. O'NEILL.  
VALVE MOTION AND CUT-OFF.

No. 190,245.

Patented May 1, 1877.

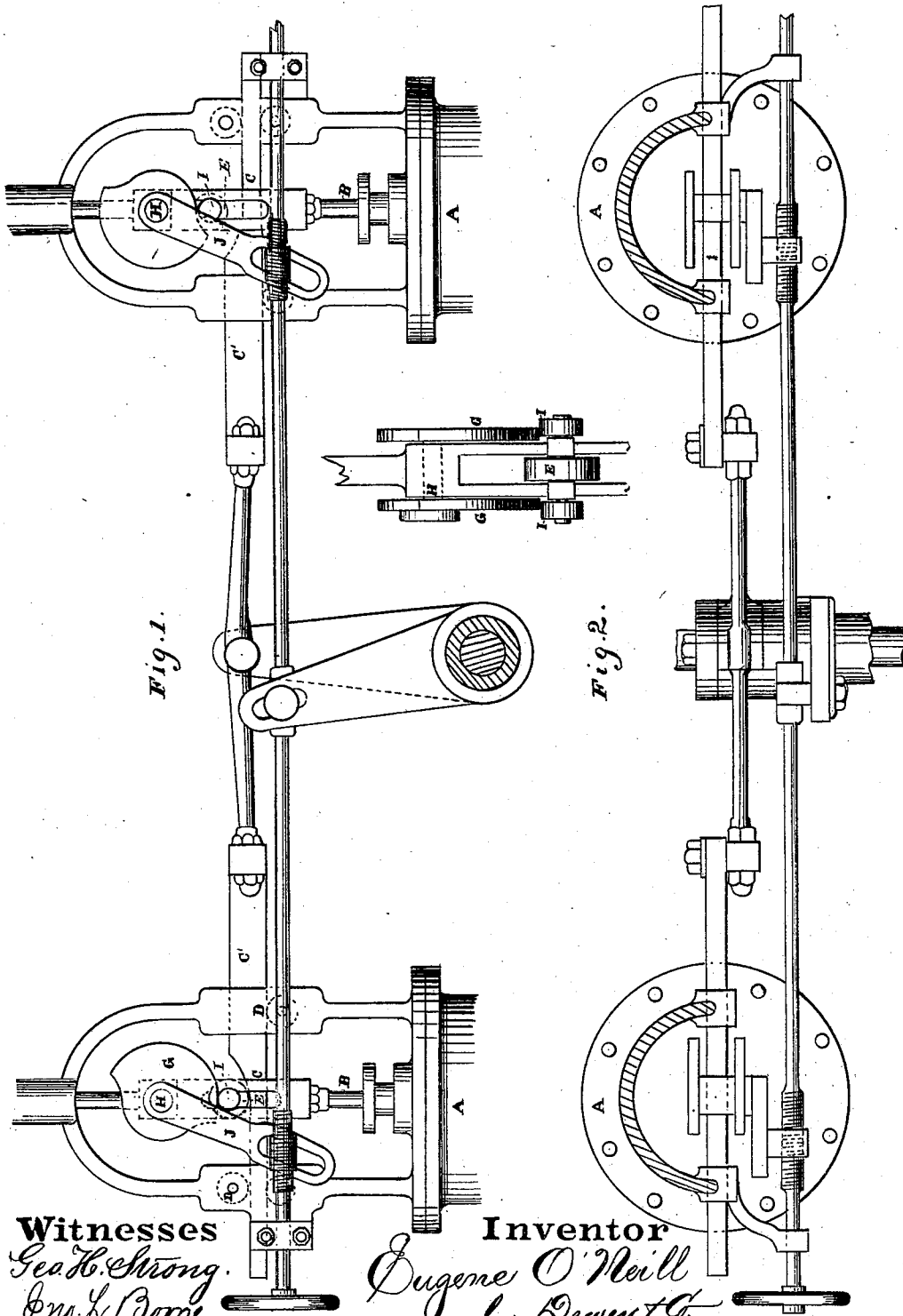

Witnesses  
*Geo. H. Strong*  
*Jno. L. Bone*

Inventor  
*Eugene O'Neill*  
*by Dewey & Co.*  
*Attys.*

# UNITED STATES PATENT OFFICE

EUGENE O'NEILL, OF OAKLAND, CALIFORNIA.

## IMPROVEMENT IN VALVE-MOTION AND CUT-OFF.

Specification forming part of Letters Patent No. **190,245**, dated May 1, 1877; application filed March 15, 1877.

### *To all whom it may concern:*

Be it known that I, EUGENE O'NEILL, of the city of Oakland, in the county of Alameda and State of California, have invented an Improved Valve-Motion and Cut-Off for Steam-Engines; and I do hereby declare the following to be a full, clear, and exact description thereof, reference being had to the accompanying drawings.

My invention relates to a novel combination of mechanism for opening and closing steam and exhaust valves in a steam-engine, the opening being effected gradually until the valve is started from its seat, and completed rapidly, while the closing of the valve is controlled by means of a cam or cams, which are made to release the valve and allow it to drop at any desired point in the stroke of the engine, the whole mechanism forming what is known as a "variable cut-off." It consists in a combination, with the vertically-acting valve and stem, of a horizontally-moving bar, having a peculiarly-shaped curve formed upon its upper side, whereby the lifting of the valve is effected; and, also, in the employment of a cam or cams in combination with the stem so actuated, that, at any desired point in the piston-stroke, it will release the valve from the action of the elevating devices, and allow it to fall and cut off any further accession of steam to the cylinder.

Referring to the accompanying drawings for a more complete explanation of my invention, Figure 1 is a side elevation of my valve-movement, showing its application to both ends of the cylinder. Fig. 2 is a plan view.

A is the top of the valve-chest designed to contain the valve M'. B is the stem, which passes through a stuffing-box in this cover, and this stem is made large enough above the stuffing-box, or has an attachment to be slotted through in two directions at right angles with each other, as shown. One of these slots receives the sliding bar C, which moves in suitable anti-friction guides at D D, and is actuated by an eccentric upon the engine-shaft, in the usual manner. The upper side of this bar is formed with the portion C' higher than the part C, so that when by its movement this part of the bar has passed beneath the roller or lifting surface E of the stem the valve will have been raised to its full opening. In order

to effect this opening with the greatest rapidity, and at the same time reduce the strain of starting the valve from its seat to a minimum, I have connected the two levels of the operating-bar by means of a peculiar curve, F, which, while it gives the requisite slow movement to start the valve from its seat, increases in such a manner as to finish opening the valve with the required rapidity, while the regular reciprocating motion of the bar is produced by the eccentric.

As it is desirable to cut off the steam from the cylinder and work it expansively, I have for this purpose attached to the valve-stem a cam, G, which is journaled to the stem at H. The lifting-surface E, upon which the bar C acts in raising the valve, may be an anti-friction surface, or, as I have shown, a roller. This roller is mounted upon an axis, which extends through the slot transverse to the one in which the bar C moves, and has rollers I upon its outer end, so that the cam G, which is double and embraces the stem, will rest upon these outer rollers. This cam is actuated, so as to receive an oscillating motion, by means of an eccentric upon the engine-shaft connected with the arm J.

The operation will then be as follows: The eccentric which actuates the bar C being set to lead the crank, in the usual manner, and the eccentric which moves the cam G being set with, or nearly with, the crank, the bar C will be moved beneath the roller E, and as the cam G rests upon the rollers, they will not be allowed to move in the slot, but the action of the curved incline will elevate the rollers, cam, and stem as one piece. This opens the valve, and it remains open until the cam is rotated upon its axis to a point where the offset L allows the stem and valve to fall, while the roller E rests upon the higher portion of the bar C'. This motion of the valve and stem is permitted by the slot in the stem, which allows the stem to move downward while the rollers remain stationary. When the further travel of the engine brings the lower part of the bar C beneath the roller or surface E it will fall to the lower level again, and the cam G will be turned by its eccentric so that its larger part is again in contact with the rollers I, and they are again in position to

lift the valve when the inclined curve passes beneath them.

The particular form of my inclined lifting-curve may be varied in different cases, and still produce, essentially, as good work; but I have found that the curve of a parabola, or one in which the curve at the beginning of the lift merges into a nearly-straight plane, answers the purpose very well.

The point of cut-off is easily regulated by lengthening or shortening by screws the rods which operate the arm J and cam G. These and the eccentrics, connecting-rods, and rock-shafts are in no way novel or different from any other of this class of mechanism, and the duplication of the gear for the opposite end of the cylinder is precisely the same, and is operated by the same eccentrics, in the same manner as in an ordinary valve-gear.

The exhaust-valves may be worked by the bar C C' alone, without the cams G.

Having thus described my invention, what I claim as new, and desire to secure by Letters Patent, is—

1. The reciprocating operating-bar, having its two levels C and C' connected by the inclined curve F, so formed that the valve shall be started from its seat by a slow movement,

and its opening completed by a more rapid movement, substantially as herein described.

2. The cam G, with its offset or curve, the cam being attached to, and moving with, the valve-stem B, in combination with the independent inclined curved face F of the operating-bar, said cam being so placed as to allow the valve to be opened and closed, substantially as herein described.

3. The valve-stem B, having the longitudinal slots made in its sides transversely to each other, in combination with the bar C and the rollers E, so that the valve-stem and rollers may be moved independent of the bar and of each other, substantially as herein described.

4. The bar C, with its inclined curved face F, in combination with the cam G, attached to the valve-stem, and the independently-moving roller E, which supports the cam until the valve is opened, and is then released by it to allow the valve to close, substantially as herein described.

In witness whereof I have hereunto set my hand and seal.

EUGENE O'NEILL. [L. S.]

Witnesses:

GEO. H. STRONG,  
FRANK A. BROOKS.