

(19) World Intellectual Property Organization
International Bureau



(43) International Publication Date
5 October 2006 (05.10.2006)

PCT

(10) International Publication Number
WO 2006/105149 A2

- (51) International Patent Classification:
H01H 9/00 (2006.01)
- (21) International Application Number:
PCT/US2006/011385
- (22) International Filing Date: 28 March 2006 (28.03.2006)
- (25) Filing Language: English
- (26) Publication Language: English
- (30) Priority Data:
11/096,438 31 March 2005 (31.03.2005) US
- (71) Applicant (for all designated States except US): INET
CONSULTING LIMITED COMPANY [JP/JP]; 1-46-1
Shinshigaya, Tsurumi-ku, Yokohama (JP).
- (72) Inventors; and
- (75) Inventors/Applicants (for US only): YUZE, Kasunori
[JP/JP]; 88 Komaoka-cho, Tsurumi-ku, Yokohama (JP).
TRACY, Larry [US/US]; 15555 William Drive, Auburn,
California 95602 (US).
- (74) Agent: YIN, Ronald, L.; DLA PIPER RUDNICK GRAY
CARY US LLP, 2000 University Avenue, East Palo Alto,
California 94303 (US).

- (81) Designated States (unless otherwise indicated, for every
kind of national protection available): AE, AG, AL, AM,
AT, AU, AZ, BA, BB, BG, BR, BW, BY, BZ, CA, CH, CN,
CO, CR, CU, CZ, DE, DK, DM, DZ, EC, EE, EG, ES, FI,
GB, GD, GE, GH, GM, HR, HU, ID, IL, IN, IS, JP, KE,
KG, KM, KN, KP, KR, KZ, LC, LK, LR, LS, LT, LU, LV,
LY, MA, MD, MG, MK, MN, MW, MX, MZ, NA, NG, NI,
NO, NZ, OM, PG, PH, PL, PT, RO, RU, SC, SD, SE, SG,
SK, SL, SM, SY, TJ, TM, TN, TR, TT, TZ, UA, UG, US,
UZ, VC, VN, YU, ZA, ZM, ZW.
- (84) Designated States (unless otherwise indicated, for every
kind of regional protection available): ARIPO (BW, GH,
GM, KE, LS, MW, MZ, NA, SD, SL, SZ, TZ, UG, ZM,
ZW), Eurasian (AM, AZ, BY, KG, KZ, MD, RU, TJ, TM),
European (AT, BE, BG, CH, CY, CZ, DE, DK, EE, ES, FI,
FR, GB, GR, HU, IE, IS, IT, LT, LU, LV, MC, NL, PL, PT,
RO, SE, SI, SK, TR), OAPI (BF, BJ, CF, CG, CI, CM, GA,
GN, GQ, GW, ML, MR, NE, SN, TD, TG).

Published:
— without international search report and to be republished
upon receipt of that report

For two-letter codes and other abbreviations, refer to the "Guidance Notes on Codes and Abbreviations" appearing at the beginning of each regular issue of the PCT Gazette.

(54) Title: A SECURE MAGNETIC SENSOR

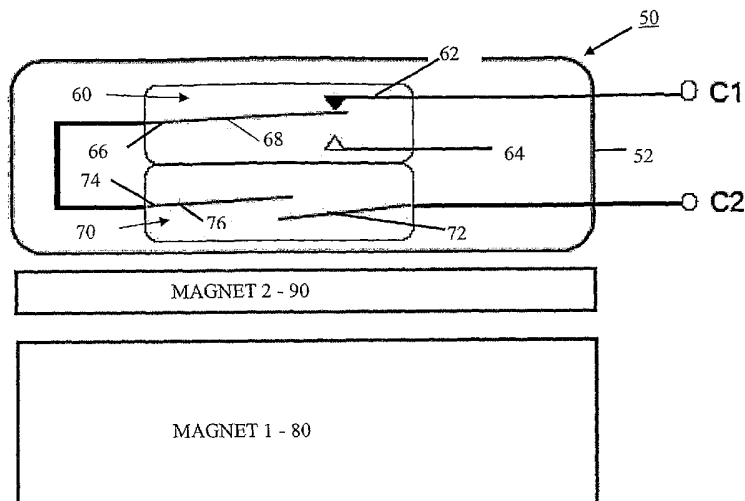

(57) Abstract: A secure magnetic sensor has a first magnetic switch activatable by a first magnetic field and a second magnetic switch activatable by a second magnetic field which is stronger than the first magnetic field. The first magnetic switch is electrically connected in series to the second magnetic switch. In the default position, the first magnetic switch is in the open position whereas the second magnetic switch is in the closed position. When the secure magnetic sensor is normally activated, the first magnetic switch is activated to close. However, when the secure magnetic sensor is tampered by the addition of a supplemental magnet, this causes the second magnetic switch to be in an open position thereby sounding an alarm.

WO 2006/105149 A2

5

A SECURE MAGNETIC SENSORTECHNICAL FIELD

The present invention relates to a secure magnetic sensor which is immune to tampering, and more particularly to a secure magnetic sensor which can detect the sensor
10 being tampered.

BACKGROUND OF THE INVENTION

Magnetic sensors are well known in the art. Referring to Figure 1A there shown a cross sectional view of a magnetic switch 10 or a reed switch 10 of the prior art. The magnetic switch 10 has three terminals: a first terminal 12, a second terminal 14, and third
15 terminal 16. A magnetic attracting member 20 has one end attached to the first terminal 12. The second end of the magnetic attracting member 20 can make electrical contact with either the second terminal 14 or the third terminal 16. In operation, one of the terminals 14 and 16 is a "dummy" terminal, in that it does not have any electrical connection to the external. The other terminal connects to an alarm switch (not shown). Assume for the
20 moment that the second terminal 14 is a "dummy" terminal and that the third terminal 16 is connected to the alarm switch.

In operation, the magnetic switch 10 is typically placed on a door frame with electrical leads connected to the first terminal 12 and the third terminal 16, as shown in Figure 1B. A magnet 30 is attached to a door. When the door is "closed" the magnet 30 is
25 sufficiently close to attract the magnetic attracting member 20 to pull it to the closed position thereby making electrical contact between the first terminal 12 and the third terminal 16. In this condition, the alarm switch (not shown) is then activated; in that an electrical connection is established sending an electrical signal through the connection of the third terminal 16, through the magnetic attracting member 20, through the first
30 terminal 12. When the door is opened or disturbed, the magnet 30 is moved. When the magnet 30 is moved sufficiently far away, the magnetic attracting member 20 reverts back to its default position which is to make contact between the first terminal 12 and the second terminal 14. In this condition, the circuit between the first terminal 12 and the third terminal 16 is broken. This can then be detected by the alarm panel and an alarm can then
35 be activated.

5 The magnetic sensor 10 of the prior art can be tampered or otherwise
circumvented by a thief or other evil doer. As can be seen in Figure 1B, there is a gap 32
that exists between the magnet 30 and the sensor 10. Before the magnetic sensor 10 is
armed, e.g. during day time, and while the door is open, a thief could place a very thin strip
of magnet immediately adjacent to the housing of the magnetic sensor 10. This
10 supplemental magnet, would have sufficient magnetic strength to attract the magnetic
attracting member 20 so that it closes the contact to electrically connect the first terminal 12
to the third terminal 16 at a time when the alarm is not activated. When it is desired to arm
the magnetic sensor 10, with the door closed, the magnet 30 is moved so that it is adjacent
to the magnetic sensor 10. However, since the supplemental magnet is already in contact
15 with the magnetic sensor 10, the presence of the magnet 30 further attracts the magnetic
attracting member 20 and continue to close the circuit between the first terminal 12 and the
third terminal 16. In this condition, when a thief returns at night time, the thief can
overcome the system by moving the door containing the magnet 30 without tripping the
alarm. The supplemental magnet resting against the housing of the magnetic sensor 10
20 would continue to keep the magnetic attracting member 20 engaged in electrical contact
between the first terminal 12 and the third terminal 16 thereby preventing the alarm signal
from being activated.

Accordingly, there is a need to overcome the deficiencies of the magnetic sensor
10 of the prior art.

25

SUMMARY OF THE INVENTION

In the present invention a secure magnetic sensor comprises a first magnetic
switch and a second magnetic switch. The first magnetic switch is activatable by a first
magnetic field. The second magnetic switch is activatable by a second magnetic field which
is stronger than the first magnetic field. The first magnetic switch is electrically connected
30 in series to the second magnetic switch.

BRIEF DESCRIPTION DRAWINGS

Figure 1A is a cross sectional view of a magnetic sensor of the prior art.

Figure 1B is a top plan view of the location of a magnetic switch of the prior art
shown in Figure 1A together with its associated magnet, in the armed position.

5 Figure 2 is a schematic diagram of the secure magnetic switch of the present invention together with its activating magnet and the supplemental magnet that a thief may use to attempt to thwart the security feature of the magnetic sensor of the present invention.

 Figure 3A-3D are electrical schematic diagrams showing other possible electrical connections for the two magnetic switches that are the components of the secure
10 magnetic sensor of the present invention.

 Figure 4 is a schematic diagram of another embodiment of the secure magnetic switch of the present invention.

DETAILED DESCRIPTION OF DRAWINGS

 Referring to Figure 2, there is shown a schematic diagram of a secure magnetic
15 sensor 50 of the present invention. The secure magnetic sensor 50 in the preferred embodiment comprises a housing 52 containing a first magnetic switch 70 and a second magnetic switch 60 positioned adjacent to one another. The first magnetic switch 70 has a first terminal 74 and a second terminal 72. The first magnetic switch 70 also has a first magnetic attracting member 76 having one end which is connected to the first terminal 74
20 and a second end. In the default position, i.e., the absence of any magnetic field, the second end of the first magnetic attracting member 76 is not connected to the second terminal 72. When a first magnetic field is brought close to the first magnetic switch 70, the first magnetic attracting member 76 is attracted to the magnetic field thereby moving the second end to be in contact with the second terminal 72, thereby closing the electrical connection
25 between the first terminal 74 and the second terminal; 72.

 The second magnetic switch 60 also has a first terminal 66, a second terminal 62, and a third terminal 64. The second magnetic switch 60 has a second magnetic attracting member 68 having a first end electrically connected to the first terminal 66. The second end of the second magnetic attracting member 68, in the absence of a second
30 magnetic field, is electrically connected to the second terminal 62. Thus, in the absence of a second magnetic field, or in the default position, the first terminal 66 is electrically connected to the second terminal 62. When a second magnetic field is brought close to the magnetic sensor 50, the second magnetic attracting member 68 is attracted to the magnetic field and the second end thereof is moved to contact the third terminal 64, thereby opening

5 the electrical connection between the first terminal 66 and the second terminal 62. The third terminal 64 is a “dummy” terminal in that it is not connected external to the magnetic sensor 50. The magnetic sensor 50, similar to the magnetic sensor 10 of the prior art, has two external connection terminals C1 and C2. Terminal C1 is connected to the second terminal 62 of the second magnetic switch 60. Terminal C2 is electrically connected to the
10 second terminal 72 of the first magnetic switch 70. The first terminal 74 of the first magnetic switch 70 is electrically connected to the first terminal 66 of the second magnetic switch 60. The first magnetic field which is sufficient to actuate the first magnetic attracting member 76 is a weaker magnetic field than the second magnetic field which is required to move the second magnetic attracting member 68.

15 The operation of the secure magnetic sensor 50 is as follows. In a default condition, in the absence of any magnetic field, the first magnetic switch 70 is in the open position, and the second magnetic switch 60 is in the closed position. Thus, in the default position, there is no electrical connection between terminal C1 and terminal C2. When a normal magnet 80 such as that attached to a door, is brought close to the secure magnetic
20 sensor 50, the magnetic field generated by the magnet 80 is sufficient only to attract the first magnetic attracting member 76 to close the first magnetic switch 70. In this condition, as can be seen from Figure 2 an electrical path is completed between first terminal C1 and second terminal 62. In this condition, the premise or the door can be armed and should the door upon which the magnet 80 is mounted is moved, the movement of the magnet 80
25 would release the first magnetic attracting member 76 returning it to its default or open position. This condition would break the electrical circuit between terminals C1 and C2 which can be detected by the alarm panel and an alarm can be activated.

To thwart a thief or evil doer who attempts to circumvent the security feature of the magnetic sensor 50, by placing a supplemental magnet 90 in the gap 32 between the
30 default magnet 80 and the secured magnetic sensor 50, this condition can be detected as follows.

If the supplemental magnet 90 is placed adjacent to the housing 52 of the secured magnetic sensor 50 during the day time before the premises are armed and secured, when the default magnet 80 is moved into position, e.g. the door is closed and is locked, the
35 presence of both the default magnet 80 and the supplemental magnet 90 creates a larger

5 magnetic field than simply the field generated by the default magnet 80 alone. In this condition, although the first magnetic attracting 76 would continue to be deflected and attracted thereby making contact between the first terminal 74 and the second terminal 72 of the first magnetic switch 70, the combined field of the default magnet 80 and the supplemental magnet 90 is sufficient to attract the second magnetic attracting member 68 to
10 break the contact between the first terminal 66 and the second terminal 62. In this manner, the premise owner, will see that with the door closed the terminal C1 and C2 does not make electrical contact. The premise owner can then investigate to determine the cause of why the alarm panel cannot be armed.

Alternatively, if somehow a thief has made an entrance into the premises and
15 desires to open the door or gate which is protected by the magnetic sensor 50, and attempts to place a supplemental magnet 90 in the gap 32 between the default magnet 80 and the secure magnetic sensor housing 52, the presence of the supplemental 90 would also attract the second magnetic attracting member 68 into the open position thereby breaking the electrical circuit between the terminals C1 and C2, to cause an alarm.

20 In either of these cases, the addition of a supplemental magnet 90 would either prevent the arming of the alarm, or would actuated the alarm when it is already armed. Thus, the secure magnetic sensor 50 of the present invention is less prone to tampering.

Electrically, the operation of the secured magnetic sensor 50 of the present invention may be viewed as two magnetic switches 60 and 70 connected electrically in
25 series with one another, with one of the magnetic switches namely second magnetic switch 60 requiring a greater magnetic field to activate it compared to the first magnetic switch 70. In the preferred embodiment, as can be seen in Figure 2 and shown in Figure 3A, the electrical connection of the two magnetic switch 60 and 70 is that the first terminal 74 of the first magnetic switch 70 is electrically connected to the first terminal 66
30 of the second magnetic switch 60. The terminals C1 and C2 of the magnetic switch 50 are connected with terminal C1 connected to the second terminal 62 of the second magnetic switch 60 and the terminal C2 connected to the second terminal 72 of the first magnetic switch 70. This is shown schematically in Figure 3A.

5 Alternatively, the first terminal 66 of the second magnetic switch 60 can be electrically connected to the second terminal 72 of the first magnetic switch 70 with the terminal C1 connected to the second terminal 62 of the second magnetic switch 60 and terminal C2 connected to the first terminal 74 of the first magnetic switch 70. This is schematically shown in Figure 3B.

10 In yet another possible connection, shown in Figure 3C, the first terminal 74 of the first magnetic switch 70 is electrically connected to the second terminal 62 of the second magnetic switch 60. The terminal C1 of the secure magnetic sensor 50 is connected to the first terminal 66 of the second magnetic switch 60 and the terminal C2 is connected to the second terminal of the first magnetic switch 70.

15 In yet another configuration, shown in Figure 3D, the second terminal 72 of the first magnetic switch 70 is electrically connected to the second terminal 62 of the second magnetic switch 60. The terminal C1 of the secure magnetic sensor 50 is connected to the first terminal 66 of the second magnetic switch 60 and the terminal C2 is connected to the first terminal 74 of the first magnetic switch 70.

20 As previously discussed, in the secure magnetic sensor 50 of the present invention, the sensor 50 has two magnetic switches each having a magnetic attracting member whose magnetic sensitivities differ from one another. For the first magnetic sensor 70, the magnetic sensitivity of the magnetic attracting member 76 is dependent upon the size of the gap between the second end of the first magnetic attracting 76 in the default
25 position and the second terminal 72 in the closed position. The distance to which the first attracting member 76 traverses is determinative of the strength of the first magnetic field that is required to activate or attract the first magnetic attracting member 76 to close the switch. As for the magnetic sensitivity of the second magnetic attracting 68, in the default position, it has a bias force urging the second magnetic attracting member 68 to maintain
30 electrical contact between the second end of the second magnetic attracting member 68 and the second terminal 62. This bias force, which is similar to the bias force shown and described for the reed switch 10 of the prior art and shown in Figure 1A, is determinative of the strength of the second magnetic field which is required to attract the second magnetic attracting member 68 into the open position.

5 Referring to Figure 4, there is shown a schematic diagram of another
embodiment of a secure magnetic sensor 150 of the present invention. The secure magnetic
sensor 150 is identical to the secure magnetic sensor 50 shown and described in Figure 2,
except as described hereinafter, and comprises a housing 52 containing a first magnetic
switch 70 and a second magnetic switch 60 positioned adjacent to one another. The first
10 magnetic switch 70 has a first terminal 74 and a second terminal 72. The first magnetic
switch 70 also has a first magnetic attracting member 76 having one end which is connected
to the first terminal 74 and a second end. In the default position, i.e., the absence of any
magnetic field, the second end of the first magnetic attracting member 76 is not connected
to the second terminal 72. When a first magnetic field is brought close to the first magnetic
15 switch 70, the first magnetic attracting member 76 is attracted to the magnetic field thereby
moving the second end to be in contact with the second terminal 72, thereby closing the
electrical connection between the first terminal 74 and the second terminal; 72.

The second magnetic switch 60 also has a first terminal 66, a second terminal 62,
and a third terminal 64. The second magnetic switch 60 has a second magnetic
20 attracting member 68 having a first end electrically connected to the first terminal 66. The
second end of the second magnetic attracting member 68, in the absence of a second
magnetic field, is electrically connected to the second terminal 62. Thus, in the absence of a
second magnetic field, or in the default position, the first terminal 66 is electrically
connected to the second terminal 62. When a second magnetic field is brought close to the
25 magnetic sensor 150, the second magnetic attracting member 68 is attracted to the magnetic
field and the second end thereof is moved to contact the third terminal 64, thereby opening
the electrical connection between the first terminal 66 and the second terminal 62. The third
terminal 64 is a "dummy" terminal in that it is not connected external to the magnetic
sensor 150. The magnetic sensor 150, however, has three external connection terminals:
30 C1, C2 and COM. Terminal C1 is connected to the second terminal 62 of the second
magnetic switch 60. Terminal C2 is electrically connected to the second terminal 72 of the
first magnetic switch 70. The first terminal 74 of the first magnetic switch 70 is electrically
connected to the first terminal 66 of the second magnetic switch 60 and is connected to the
external terminal COM. The first magnetic field which is sufficient to actuate the first
35 magnetic attracting member 76 is a weaker magnetic field than the second magnetic field
which is required to move the second magnetic attracting member 68.

5 In the operation of the sensor 150, the operation of the terminals C1 and C2 has
been described heretofore, with respect to arming the sensor 150 and detecting when a
supplemental magnet 90 is present. With the third terminal COM, it is possible to detect
when the supplemental magnet 90 is placed in the vicinity of the sensor 150. Thus, the
leads COM and C1 can be armed during the day. When the supplemental magnet 90 is
10 placed adjacent to the housing 52, this condition can be detected by the deflection of second
magnetic attracting member 68. In this manner, the presence of the supplemental magnet 90
can be immediately detected. Thus, if during the non-armed mode (i.e. day time) when a
thief adds the supplemental magnet 90, in the prior art, this condition would not be detected
until closing time. At which point, the alarm company is also closing, and it would be
15 difficult for the alarm company to send a technician out to the protected premises to
diagnose the problem. In such event, typically, the zone containing the "defective" sensor is
by-passed, permitting the intruder to enter the premises at night time. However, with this
embodiment, as soon as the supplemental magnet 90 is added, this condition is detected, and
a 24 hour monitoring zone is then broken, and a technician can be sent immediately to
20 diagnose the problem. Often, the placement of a supplemental magnet 90 is only one of
many acts that a thief or intruder might use to defeat the alarm system.

5 WHAT IS CLAIMED IS:

1. A secure magnetic sensor comprising:
 - a first magnetic switch activatable by a first magnetic field;
 - a second magnetic switch activatable by a second magnetic field, different from
10 said first magnetic field, wherein said second magnetic field is stronger than said first
magnetic field; and
 - said first magnetic switch is electrically connected in series to said second
magnetic switch.
2. The sensor of claim 1 wherein said first magnetic switch is positioned adjacent
to said second magnetic switch.
- 15 3. The sensor of claim 1 wherein said first magnetic switch is operable in one of
two modes: a first mode wherein in the presence of said first magnetic field said first
magnetic switch is closed, and a second mode wherein in the absence of said first magnetic
field said first magnetic switch is open.
4. The sensor of claim 3 wherein said second magnetic switch is operable in one of
20 two modes: a first mode wherein in the presence of said second magnetic field said second
magnetic switch is open, and a second mode wherein in the absence of said second
magnetic field said second magnetic switch is closed.
5. The sensor of claim 4 wherein said first magnetic switch has a first terminal and
a second terminal, and a magnetic attracting member having a first end connected to said
25 first terminal and a second end operable to electrically connect said first terminal to said
second terminal in the presence of said first magnetic field, and operable to disconnect said
first terminal to said second terminal in the absence of said first magnetic field.
6. The sensor of claim 5 wherein said second magnetic switch has a first terminal
and a second terminal, and a magnetic attracting member having a first end connected to
30 said first terminal and a second end operable to electrically connect said first terminal to
said second terminal in the absence of said second magnetic field, and operable to

5 disconnect said first terminal to said second terminal in the presence of said second
magnetic field.

7. The sensor of claim 6 wherein said first terminal of said first magnetic switch is
electrically connected to said first terminal of said first magnetic switch, and wherein said
secure magnetic sensor has two contacts: the second terminal of said first magnetic switch,
10 and the second terminal of said second magnetic switch.

8. The sensor of claim 6 wherein said first terminal of said second magnetic switch
is electrically connected to the second terminal of said first magnetic switch, and wherein
said secure magnetic sensor has two contacts, the second terminal of said second magnetic
switch and the first terminal of said first magnetic switch.

15 9. The sensor of claim 6 wherein said second terminal of said second magnetic
switch is electrically connected to the first terminal of said first magnetic switch, and
wherein said secure magnetic sensor has two contacts, the first terminal of said second
magnetic switch and the second terminal of said first magnetic switch.

10 10. The sensor of claim 6 wherein said second terminal of said second magnetic
switch is electrically connected to the second terminal of said first magnetic switch, and
wherein said secure magnetic sensor has two contacts, the first terminal of said second
magnetic switch and the first terminal of said first magnetic switch.

11. The sensor of claim 7 wherein said second end of said magnetic attracting
member of said first magnetic switch is operable to traverse a gap in the presence of said
25 first magnetic field, wherein said gap is determinative of the strength of the first magnetic
field required to activate said first magnetic switch.

12. The sensor of claim 11 wherein said magnetic attracting member of said second
magnetic switch has a bias to maintain electrical contact between the second end of said
magnetic attracting member and said second terminal, wherein said bias is determinative of
30 the strength of the second magnetic field required to activate said second magnetic switch.

- 5 13. A magnetic sensor comprising:
 a first magnetic attracting member activatable by a first magnetic field, for
 electrically connecting a first terminal to a second terminal;
 a second magnetic attracting member activatable by a second magnetic field for
 disconnecting an electrical connection from a third terminal to a fourth terminal; wherein
10 said second magnetic field is stronger than said first magnetic field;
 said second terminal electrically connected to said third terminal; and
 wherein said sensor has two contacts: the first terminal and the fourth terminal.
14. The sensor of claim 13 wherein said first magnetic attracting member is operable
 to traverse a gap in the presence of said first magnetic field, wherein said gap is
15 determinative of the strength of the first magnetic field required to activate said first
 magnetic attracting member.
15. The sensor of claim 14 wherein said second magnetic attracting member has a
 bias to maintain electrical contact between the second magnetic attracting member and said
 fourth terminal, wherein said bias is determinative of the strength of the second magnetic
20 field required to activate said second magnetic switch
16. The sensor of claim 13 wherein said sensor has three contacts: the first terminal,
 the fourth terminal and the second terminal.

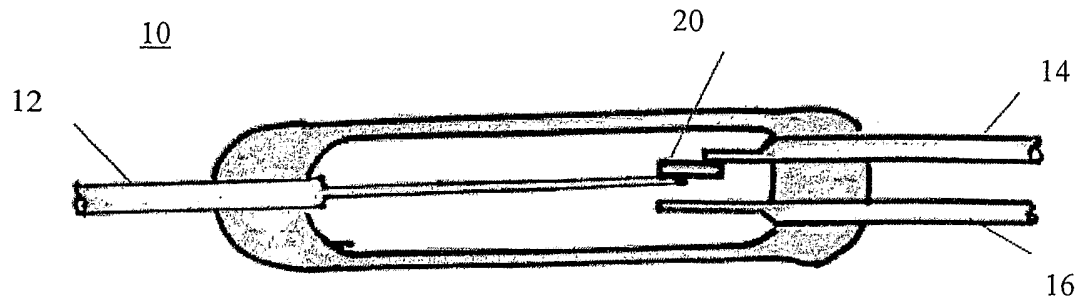

Figure 1(a) – Prior Art

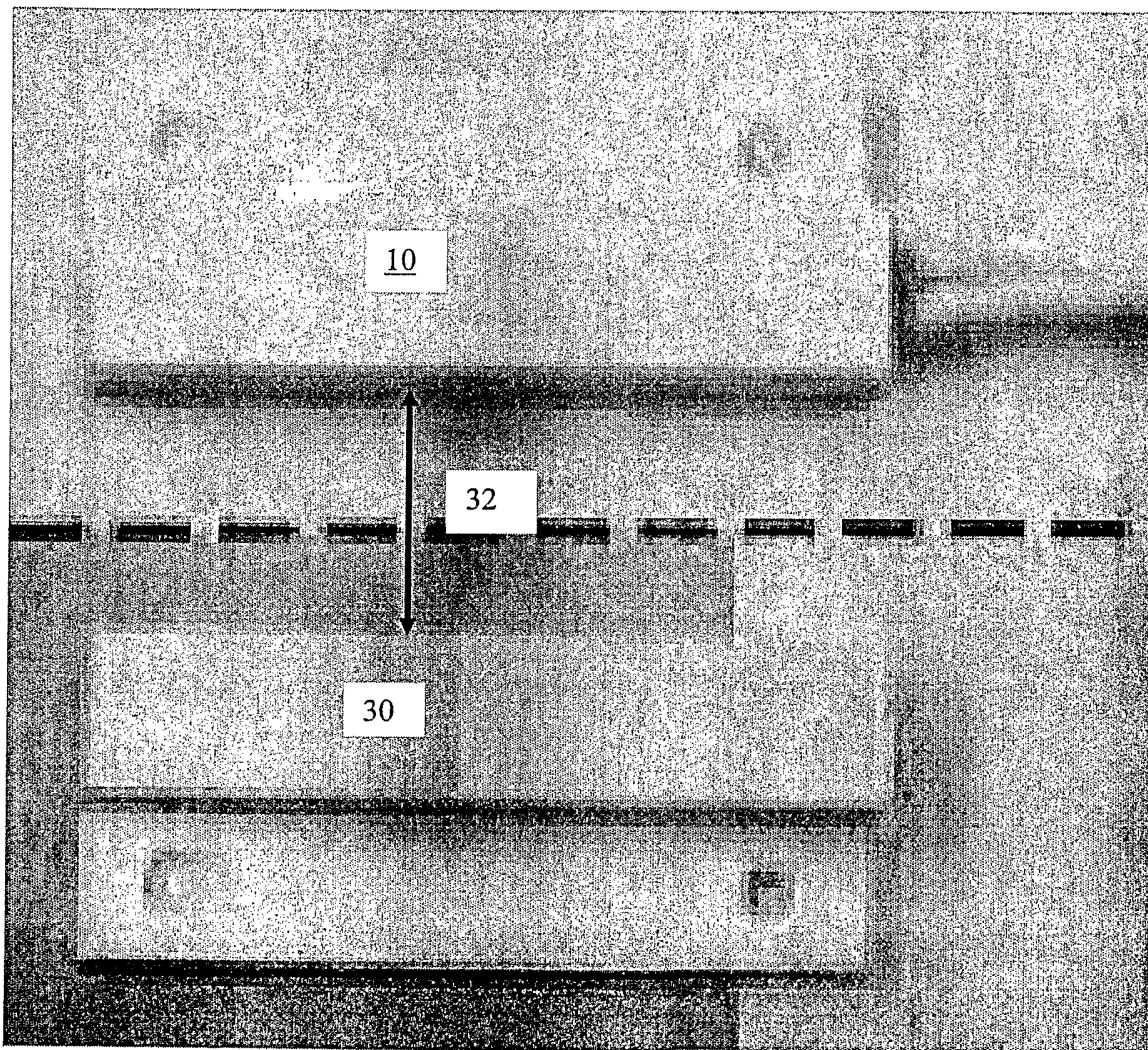

Figure 1(b) – Prior Art

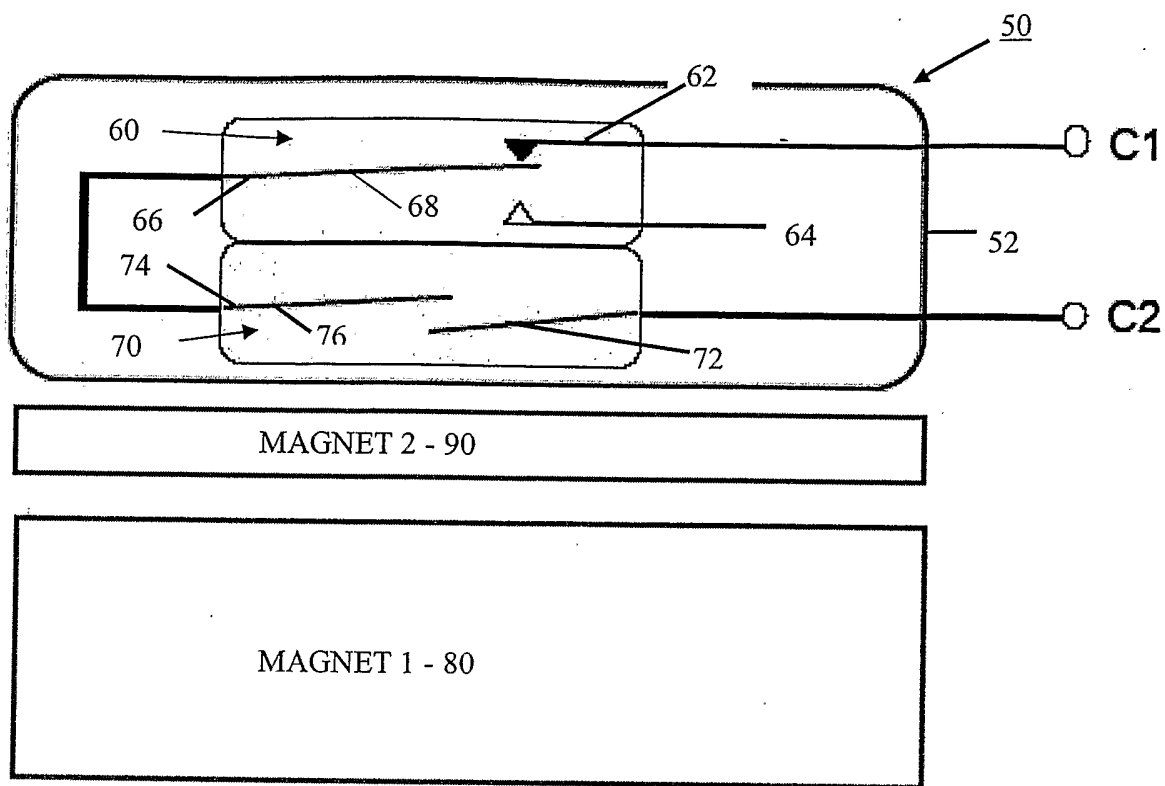

Figure 2

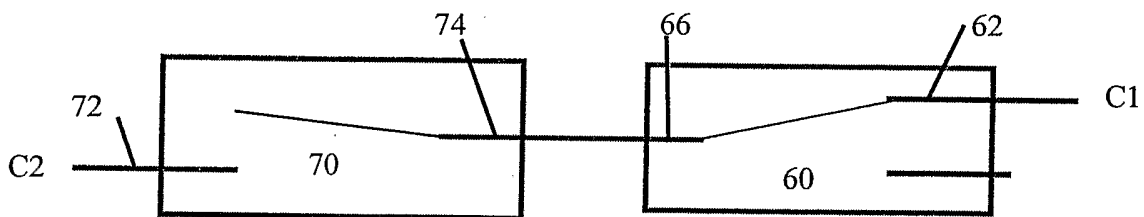

Figure 3A

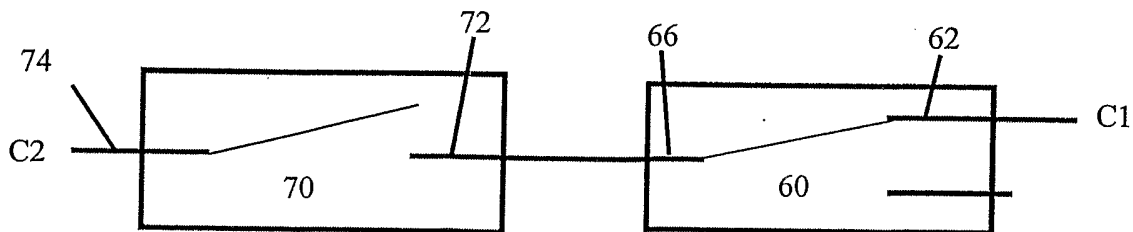

Figure 3B

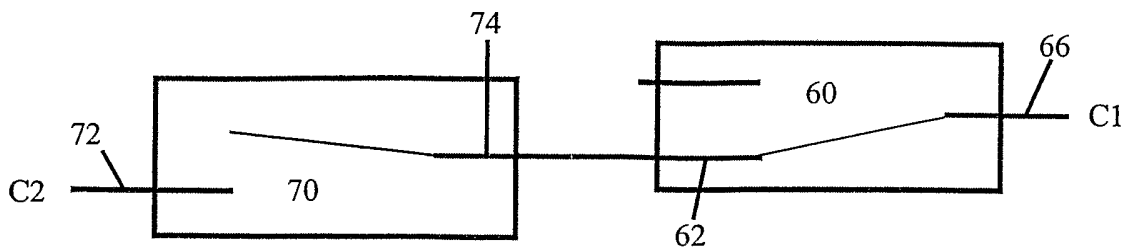

Figure 3C

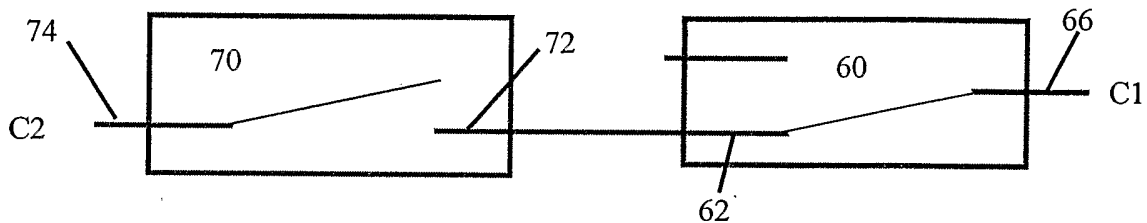

Figure 3D

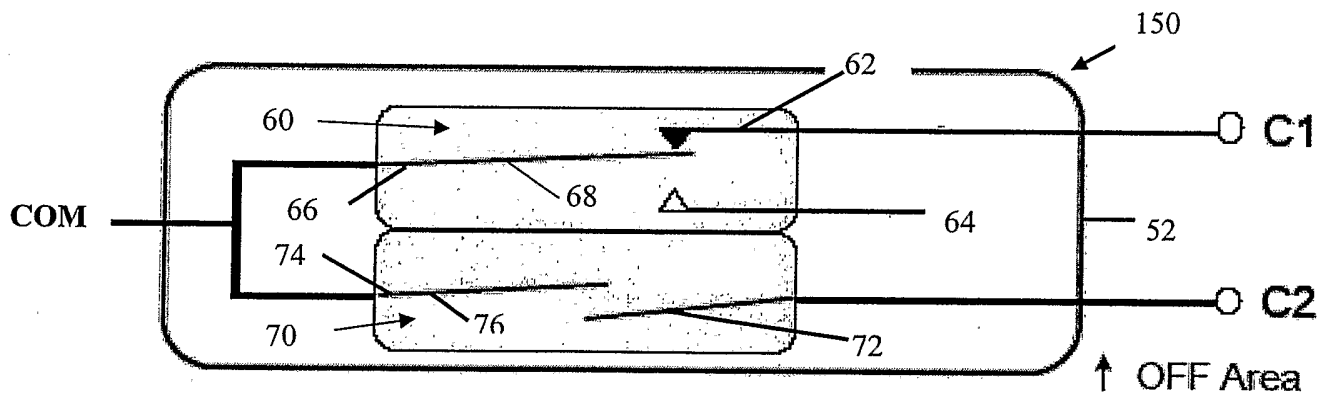

Figure 4