

No. 758,200.

PATENTED APR. 26, 1904.

J. E. BENNETT.  
TELEPHONE CLIMBER'S SEAT.  
APPLICATION FILED DEC. 20, 1902.

NO MODEL.

3 SHEETS—SHEET 1.

Fig. 1.

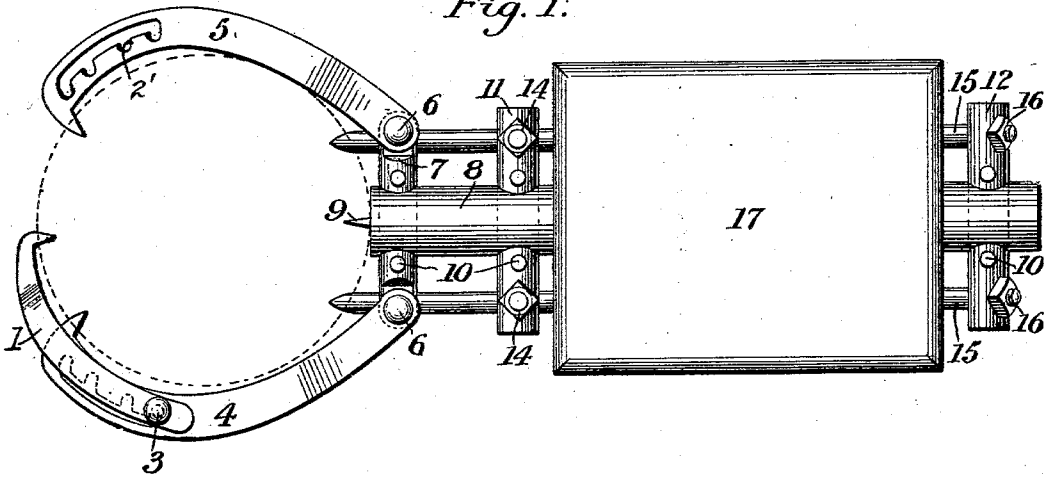
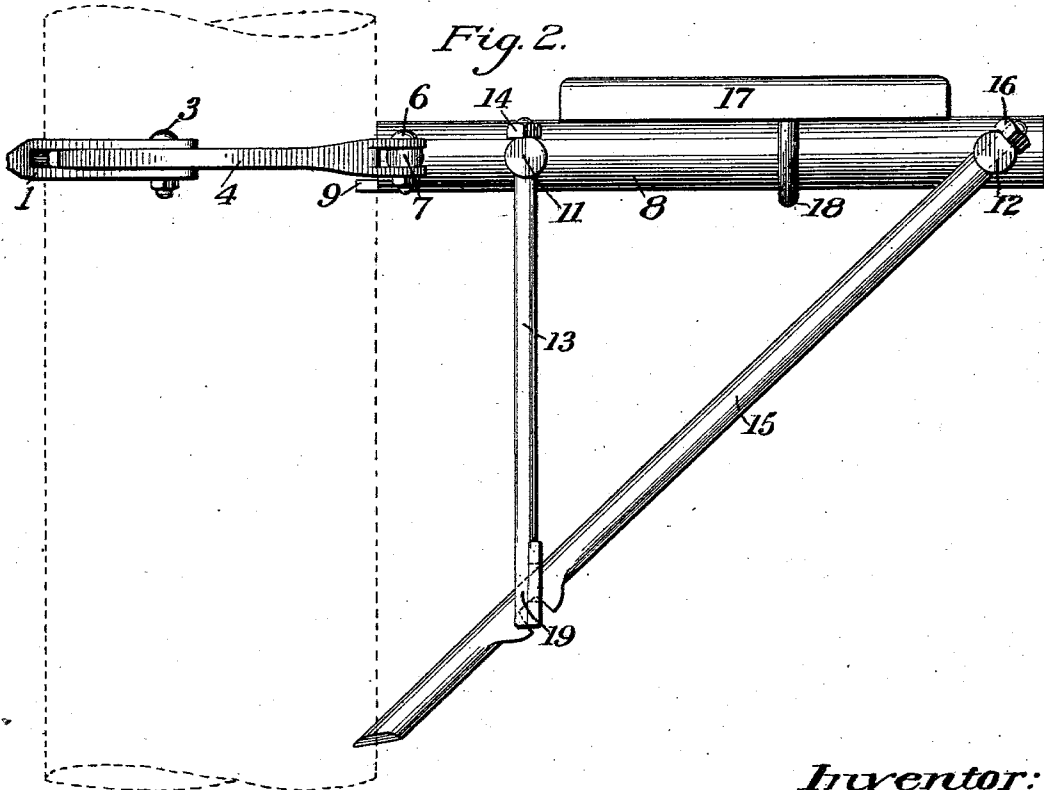

Fig. 2.



Witnesses:

B. F. Gray  
L. H. Colburn

Inventor:

James E. Bennett  
By J. W. Tower  
Attorney

No. 758,200.

PATENTED APR. 26, 1904.

J. E. BENNETT.  
TELEPHONE CLIMBER'S SEAT.

APPLICATION FILED DEC. 20, 1902.

NO MODEL.

3 SHEETS—SHEET 2.

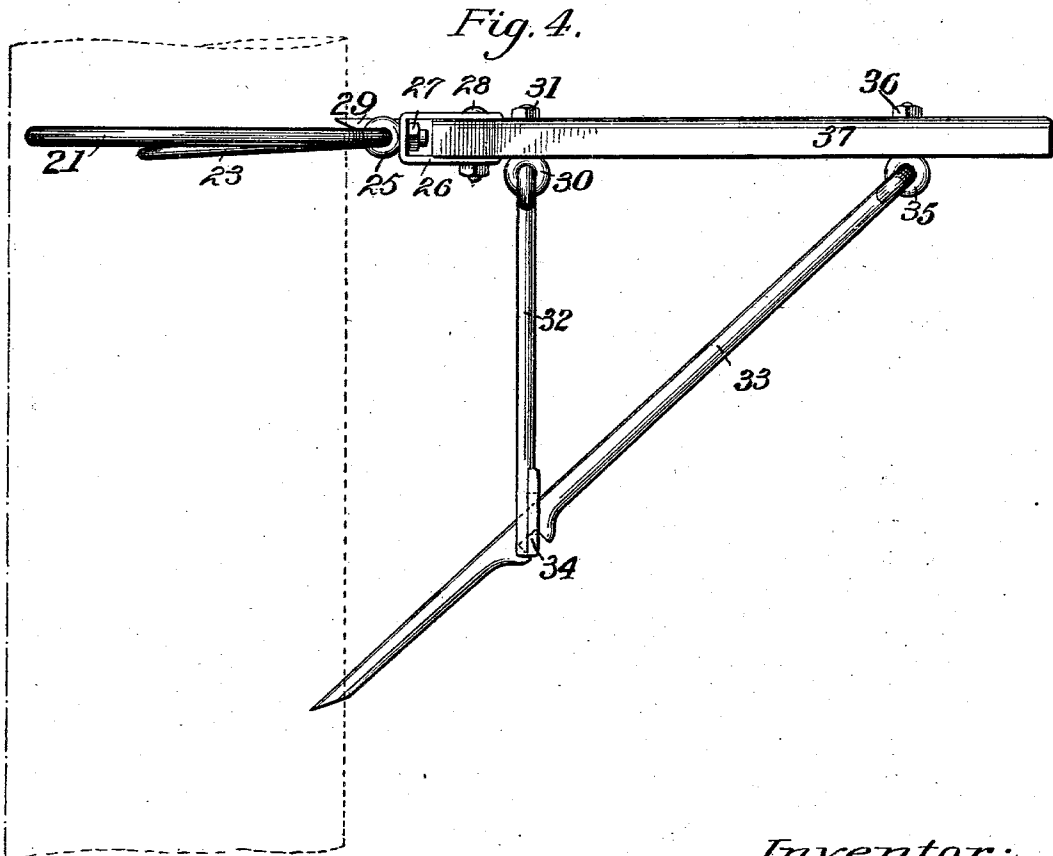
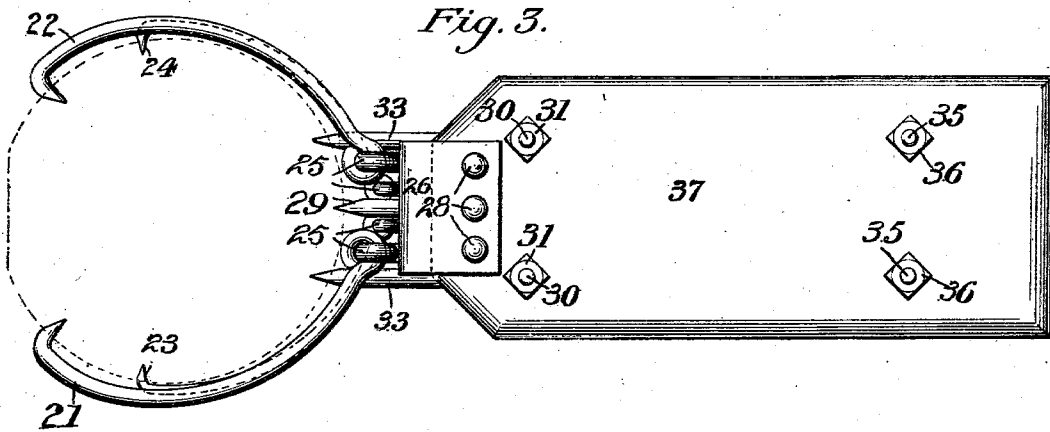

Witnesses:  
B. F. Gray  
J. W. Perkins

Inventor:  
James E. Bennett  
By J. W. Tower  
Attorney

No. 758,200.

PATENTED APR. 26, 1904.

J. E. BENNETT.  
TELEPHONE CLIMBER'S SEAT.  
APPLICATION FILED DEC. 20, 1902.

NO MODEL.

3 SHEETS—SHEET 3.

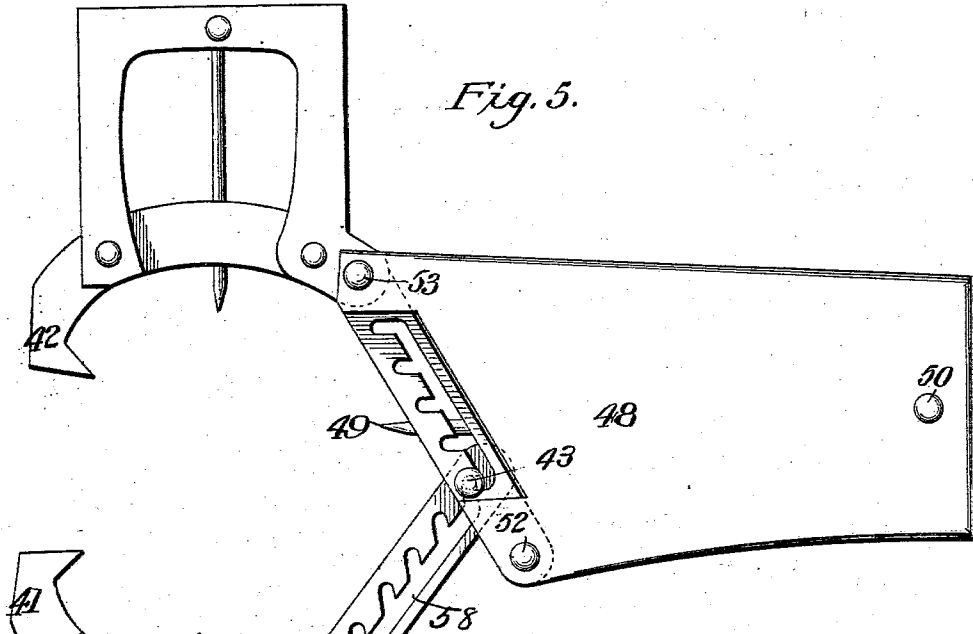

Fig. 5.

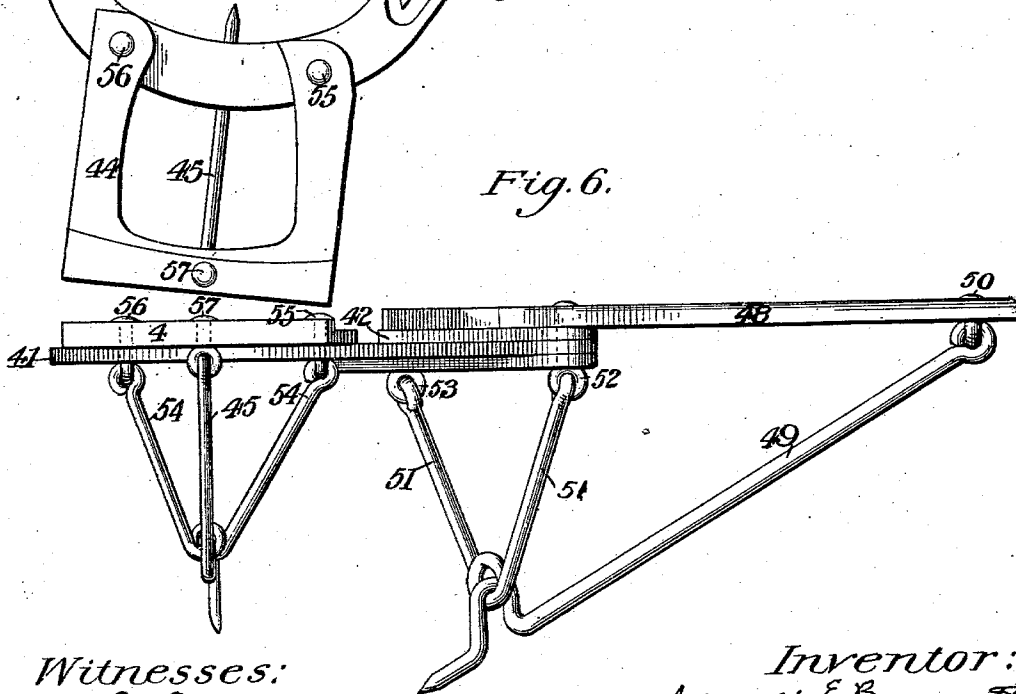

Fig. 6.

Witnesses:  
B. H. Gray  
J. W. Calhoun

Inventor:  
James E. Bennett  
By J. W. Tower  
Attorney

# UNITED STATES PATENT OFFICE.

JAMES E. BENNETT, OF MOMENCE, ILLINOIS.

## TELEPHONE-CLIMBER'S SEAT.

SPECIFICATION forming part of Letters Patent No. 758,200, dated April 26, 1904.

Application filed December 20, 1902. Serial No. 136,025. (No model.)

*To all whom it may concern:*

Be it known that I, JAMES EDWARD BENNETT, a citizen of the United States of America, and a resident of Momence, in the county of Kan-  
 5 kakee and State of Illinois, have invented a certain new and useful Improvement in Telephone-Climbers' Seats, of which the following is a specification.

The support in use by climbers at the present  
 10 time is a strap around the climber's waist in which an iron ring is fastened on either side of the climber. Another strap, with a snap at each end, is passed around the pole and snapped into the rings on either side of the  
 15 climber, thereby holding him near the pole. Often the climber holds himself from falling away from the pole with one hand and arm while he does his work with the other hand. In each instance the weight of the climber is  
 20 supported by his having spurs fastened upon his boots, which enter the pole, said spurs being upright irons pointed at the bottom end and turned in toward the pole.

My invention is an improvement in a tele-  
 25 phone-climber's support, it being a seat capable of adjustment to the pole by fingers or tongs, two or four in number, and supported by legs which enter the pole at an angle below the seat. It enables the climber to be  
 30 conveniently and securely seated at a proper distance from his work, with both hands and arms free with which to perform his task.

The invention consists of certain novel features of construction, combination, and arrangement of parts, which are hereinafter  
 35 more fully described, and pointed out with reference to the accompanying drawings.

Figure 1 is a plan view of my improved telephone-climber's seat, the top parts being  
 40 shown in operative relation to each other. The fingers hook into the pole on each side of the same after the manner of tongs. Fig. 2 shows the side elevation of the same parts connected to a pole. Fig. 3 is a plan view of  
 45 a modification of my improved climber's seat, the top parts being shown in operative relation to each other. The general principles are very similar to those in Figs 1 and 2, although the construction is somewhat different. Fig.  
 50 4 is a side perspective of the seat shown in

Fig. 3, the parts being connected to a pole. Fig. 5 is a plan view of still another modification of my improved telephone-climber's seat, together with attached steps. It is similar in  
 55 principle, but differs somewhat in construction from the seat shown in Figs. 1 and 3. Fig. 6 is a side elevation of the parts shown in Fig. 5, the same being ready to connect with a pole.

In Figs. 1 and 2, 4 and 5 represent the two  
 60 fingers which hook into the pole on either side. 1 represents an auxiliary finger, which is fastened to finger 4 by bolt 3 and slips backward and forward in the cut-out and is adjustable by means of the notches shown in the  
 65 cut-out, as in 2'. The finger corresponding to 1 is not shown on finger 5, but is left out in order to show the cut-out and notches. Fingers 4 and 5 will hook into any ordinary  
 70 sized pole, and the auxiliary fingers make possible the attaching of the seat to a much larger pole. Fingers 4 and 5 fasten onto cross-bar  
 75 7 with bolts 6. Bar 7 passes through and is designed to turn in a round hole in seat-pipe 8. 9 is a sharp-pointed iron at the same end  
 80 of pipe 8 as the fingers or tongs. It easily enters the pole and assists to support the seat in a proper and comfortable manner. 10 indicates small bolts passing through bars 7, 11,  
 85 and 12 to keep pipe 8 from slipping to one side. 11 is a cross-bar through pipe 8, and to it are fastened two arms 13, which pass through  
 90 either end of bar 11 and are fastened by taps 14. 12 is another bar that passes through pipe 8 near the opposite end from the fingers  
 95 or tongs. At either end of bar 12 two legs 15 pass through and are fastened with taps 16. Legs 15 drop down at an angle below seat 17,  
 100 pass through cross-piece 19, and enter the pole with sharpened points and serve as supports to seat 17. Cross-piece 19 and arms 13 maintain legs 15 in their proper positions. Seat 17 can be made of any suitable material.

In Figs. 3 and 4 fingers 21, 22, 23, and 24  
 105 hook into the pole on either side after the manner of tongs. Fingers 23 and 24 will hook into any ordinary sized pole, and it is intended that either the long or the short pair of fingers, or both, may be used, according to  
 110 the size of the pole. The fingers 21, 22, 23,

and 24 fasten to staple-bolts 25, which in turn pass through seat-plate 26 and are fastened by means of taps 27. Seat-plate 26 is fastened to the front part of seat 37 by means of three bolts 28. 29 is a pointed iron fastened in front of seat-plate 26 and intended to enter the telephone or telegraph pole and assist in holding seat 37 in a proper and comfortable position. Two arms 32 are fastened to seat 37 by means of staple-bolts 30, passing through seat 37 and fastened to taps 31. Legs 33 are fastened to the rear of seat 37 by means of bolts 35, which pass through seat 37 and are secured by taps 36. Legs 33 drop down at an angle below seat 37, pass through cross-piece 34, and with sharpened end enter the pole and serve as supports to seat 37. Arms 32 and cross-piece 34 maintain legs 33 in their proper positions. Seat 37 may be made of any suitable material, perhaps best of plank.

Figs. 5 and 6 still follow the general principle, but are somewhat different in details of construction. Fingers 41 and 42 hook into the pole on either side after the manner of tongs. Finger 42 is fastened to seat 48 by means of bolts 52 and 53. Finger 41 has a notched cut-out 58. Finger 42 is cut out where it is attached to seat 48. Finger 41 is attached to seat 48, and finger 42 by bolt 43, which may roll from notch to notch, thereby making the fingers adjustable to any sized pole. Double arm 51 is fastened to bolts 52 and 53 at the bottom of seat 48 and serves to support leg 49. Leg 49 is fastened to back of seat 48 by staple-bolt 50. Leg 49 drops down at an angle below seat 48 and passes through double arm 51 and with sharpened point enters the pole and serves as a support to seat 48. 44 is a step attached to finger 41 by means of staple-bolts 55 and 56, to which bolts double arm 54 is attached. Leg 45 is attached to step 44, passing through double arm 54 and with sharpened point enters the pole below the finger 41 and serves as a support for the step and seat. Step 60 corresponds to step 44 and is attached to finger 42

in manner similar to the attachment of step 44 finger 41.

Any one of these seats may be fastened to a telegraph or telephone pole at any desired height, and various changes in the form, proportion, and details of construction may be made within the scope of the invention without departing from the spirit or sacrificing any of the advantages thereof.

Having thus described my invention, what I claim, and desire to secure by Letters Patent, is—

1. The combination of a telegraph or telephone climber's seat attachable to a pole at any height comprising fingers or tongs which hold the seat in place and which are capable of adjustment to any sized pole, the legs secured to the seat and entering the pole at an angle below the seat and the arms holding up said legs, and the legs said seat, substantially as described.

2. A telegraph or telephone climber's seat attachable to a pole at any height constructed with fingers or tongs capable of adjustment to any sized pole and fastened to staple-bolts which in turn pass through the seat-plate, the seat-plate being fastened to the front part of the seat by means of bolts, arms and legs held up by staple-bolts passing through the seat and fastened with taps, the legs going through the arms and entering the pole at an angle below the seat, substantially as described.

3. The combination with a seat attachable to a pole at any height, of fingers or tongs which hold the seat in place and which are capable of adjustment to any sized pole, a leg or legs secured to the seat and entering the pole at an angle below the seat, an arm or arms to hold up said leg or legs, steps at either side of the pole, fastened to the fingers or tongs and a leg or legs for supporting said seat or steps, substantially as described.

JAMES E. BENNETT.

Witnesses:

J. W. TOWER,  
H. C. REINS.