

19



Europäisches Patentamt
European Patent Office
Office européen des brevets



11 Publication number:

0 322 935 B1

12

EUROPEAN PATENT SPECIFICATION

- 45 Date of publication of patent specification: **02.06.93** 51 Int. Cl.⁵: **E02F 5/12, E02F 5/10, E02F 5/14, E02F 3/90**
- 21 Application number: **88202340.1**
- 22 Date of filing: **19.10.88**

- 54 **Process and device for depositing loose material under water, in particular covering a pipe or the like.**

30 Priority: **24.12.87 NL 8703137**

43 Date of publication of application:
05.07.89 Bulletin 89/27

45 Publication of the grant of the patent:
02.06.93 Bulletin 93/22

84 Designated Contracting States:
BE DE ES FR GB IT NL

56 References cited:
WO-A-83/00060
NL-A- 6 901 482
NL-A- 7 806 662
NL-A- 8 201 952

73 Proprietor: **HOLLANDSCHE BETON GROEP N.V.**
Generaal Spoorlaan 489 Boîte Postal 81
NL-2280 AB Rijswijk(NL)

72 Inventor: **Van der Schrieck, Gérard Louis Marie**
Thorbeckelaan 24
NL-2613 BW Delft(NL)

74 Representative: **Baarslag, Aldert D. et al**
Nederlandsch Octrooibureau Schevening-
seweg 82 P.O. Box 29720
NL-2502 LS 's-Gravenhage (NL)

EP 0 322 935 B1

Note: Within nine months from the publication of the mention of the grant of the European patent, any person may give notice to the European Patent Office of opposition to the European patent granted. Notice of opposition shall be filed in a written reasoned statement. It shall not be deemed to have been filed until the opposition fee has been paid (Art. 99(1) European patent convention).

Description

The invention relates to a process for depositing loose material under water, in which the loose material, mixed with water, is fed in at or near the bottom of the body of water through a pipe which has an outflow aperture and is directed downwards from a movable device, such as a vessel, while during the infeed of this mixture the device with the pipe is moved along a specific course, so that the outflowing mixture separates under water into water and loose material, the loose material being deposited on the bottom of the body of water.

Such a process is known from NL-A-7806662. The problem which occurs here is that the mixture of water and loose material flowing out of the mouth of the pipe spreads more or less rapidly depending on the particle size of the loose material and the emerging quantity of loose material per unit time, due to the fact that the stream of mixture emerging from the mouth represents a certain amount of energy and drags along surrounding water. This results in a spread of the loose material over a much greater area than is desired, in particular when currents also occur in the water at the mouth of the outflow. This problem is greatest in the case of fine-grained material, such as fine sand, with a particle size, for example, in the order of magnitude of 100 to 200 μm (micrometers).

Making an accumulation properly or covering an object such as a pipe or cable properly is therefore difficult to achieve with a fairly reasonable output.

The object of the invention is to produce a process with which it is in fact possible to deposit loose material, in particular fine-grained loose material, such as fine sand, in the correct place in the correct form, without the loose material spreading in a more or less arbitrary manner.

This object is achieved according to the invention in the first place and in principle in that, viewed in the direction of the course, the loose material mixture is made to flow out divided over a great length of the course through apertures provided in the wall of said pipe near the end thereof succeeding one another in the direction of the course, in such a way that the delivery from the pipe is distributed over this great length.

This thus means that according to the invention the mixture of water and loose material which is fed in through the pipe does not flow out through a single aperture, but through a large number of apertures lying in the direction of the course, while the delivery, i.e. the volume per unit time, flowing through the pipe is distributed among these apertures. Jets of mixture which have a small loose material outflow per aperture then emerge from the many apertures. If the pipe with the apertures is on

or close to the area to be covered, then settling can take place a short distance away without the admixture of surrounding water. Since the device, such as the vessel, moves along the course to be treated, in this way the pipe provided with outflow apertures and trailing along the bottom of the body of water or moving just above it forms a ridge of loose material which can serve to cover a line or cable, but which can also be used to build up a body, such as a sand body.

The device for using the process according to the invention can be achieved in many different ways.

In a device which consists of a vessel, a pipe directed downwards from the vessel, and an outflow mouth at the end of the pipe, the device according to the invention can be characterized in that the outflow mouth comprises a length of tubing which runs parallel to the bottom of the body of water and is provided with apertures distributed along the length of tubings, said apertures together with the then throttled end aperture of the length of tubing forming a passage which can process the delivery of the pipe. This length of tubing can be connected to the pipe by means of hinges with at least two pins standing at right angles to each other, and can be controlled in this way. It can therefore also be held just above the bottom, so that the outflow distance for the jets of mixture is as small as possible.

The length of tubing can be a rigid pipe, but it can also be a flexible hose. The condition is that it is provided with series of outflow apertures along a great length, for example 10 to 15 meters.

If use is made of a rigid pipe the position of which can be determined accurately by means of controllable hinges, then it can be useful according to the invention to provide on top of the pipe a flexible flap which extends on either side thereof, and the length of which is at least equal to the tubing provided with apertures. This flexible flap hangs downwards, preferably in contact with the bottom, and prevents loose material from flowing away laterally.

It is also conceivable for these flaps on either side of the length of tubing to be connected at the front and rear side by an intermediate flap, this intermediate flap being lower in height than the flap to which it is connected.

If such a flexible flap is used, the outflow apertures are preferably disposed in the top part of the length of tubing. This flap can be made of tight material, but is preferably made of material which is permeable to water, but which retains the loose material. The loose material is in this way expelled from the jets and forced by the flap to settle on the bottom. Admixture with surrounding water can be fully counteracted in this way.

Apertures can, however, also be provided in the bottom part of the length of tubing.

If the length of tubing is a flexible hose, which is dragged along the bottom, it preferably has the apertures in the top parts of the side wall. However, it is then possible to connect several lines, such as, for example, two or more hoses which are fixed to a manifold, which is in turn fixed to the end of the pipe.

If there are more than two hoses, the outermost hoses can be largely or fully left without lateral apertures, and the outermost hoses are longer than the innermost. A good lateral boundary is obtained in this way.

If two hoses are used, use can be made again of a flexible flap which is carried by a carrier which projects above and between the hoses and is fixed to the manifold. Here again, control can be carried out by controlling the bottom end of the pipe, for example by means of cardan joints with operating cylinders disposed therein.

Instead of a rigid pipe or a flexible hose with circular cross section, it is also possible according to the invention for the length of tubing to be a funnel which from the pipe onwards has a flow cross section which increases in the direction of flow and is provided with outflow apertures in the wall. The increase in cross section results in a speed reduction, and thus a reduction in the emerging partial jets.

The height of this funnel can decrease in the direction of flow, so that only one outlet slot is left at the end of the funnel.

The funnel can also pass gradually in the direction of flow from the circular cross section of the pipe to a horizontal crescent shape. The shape itself then provides protection against the admixture of surrounding water, and this shape is particularly beneficial for the covering of a pipe.

The invention will now be explained in greater detail with reference to the drawings.

Fig. 1 shows an embodiment of the device according to the invention, in perspective.

Fig. 2 shows another embodiment of the device for carrying out the process according to the invention, in perspective.

Fig. 3 is a cross section through the length of tubing provided with apertures, according to the embodiment of Fig. 1.

Fig. 4 shows schematically in cross section the application with two hoses.

Fig. 5 shows the application with two hoses on a flap.

Fig. 6 shows schematically the embodiment of Fig. 5 in top view.

Fig. 7 shows schematically in top view the embodiment with a funnel.

Fig. 8 is a cross section along the line VIII-VIII of Fig. 7.

Fig. 9 is a cross section along the line IX-IX of Fig. 7.

Fig. 10 shows schematically yet another variant.

Fig. 1 indicates by 1 the side of a hopper. Coming out of this side wall of the hopper via an elbow 2 is a downward-slanting pipe 3, which is connected to the elbow by means of hinge arms 4, said hinge being straddled by a bellows 5. Said pipe 3 is suspended from the hopper by cables, such as the cable 6.

Provision is made on the bottom of the pipe 3 for a cardan joint which is shown in its entirety by 7, and is provided with a horizontal hinge 8 and a vertical hinge 9. This joint is also straddled in a known manner by means of a bellows 10. The pipe section 11 going out from the cardan joint 7 has connecting to it a pipe 12, which is provided along its entire length with slits or apertures 13, and the end of which is closed, with the exception of a small aperture 14, or is provided with a pre-tensioned flap 14.

A pipe to be covered, which can lie in a channel, is indicated by 15.

A flap 16 is placed over the tubing 12 provided with slits 13 and - as shown in Fig. 3 - is held at some distance from the top wall of the length of tubing 12 by a support 17, and on either side thereof hangs down and is in contact with the bottom 18 of the water. The flaps 16 can, if desired, be provided on the front or rear end with a cross flap 16" which does not entirely reach the bottom.

The mixture emerging from the slits 13 forms an accumulation, indicated in its entirety by 19, under the flaps 16', 16" (vide Fig. 3).

The hopper 1 is advanced parallel to the course of the pipe 15 to be covered, so that during this advance an unbroken accumulation or sand ridge which covers the pipe 15 is formed.

It is possible to check with a sensor 20, which is known per se, whether the length of tubing provided with apertures is actually moving along the correct course.

In the embodiment of Fig. 2 a flexible hose 21, which hangs down in a curve and rests with a long part 21' on the course to be covered, is connected to the pipe section 11 of the pipe 3, which is designed in the same way as shown in Fig. 1.

This hose is provided in the side walls with slit-type out-flow apertures 22, from which mixture jets 23 emerge.

Since the hose is moved forward with the hopper along the course of the pipe 15, the hose part 21' will remain stably in the accumulation forming. The accumulation 19' obtained is flatter in shape. In this embodiment provision is made for a number of

upward-directed jets or an aperture 14 to fill in the channel left by the hose 21'.

Fig. 4 shows how an accumulation 28 can be formed by means of two hoses 24, 25 with lateral outflow apertures 26, 27.

The outflow apertures can here be disposed largely or entirely in the sides of the hoses facing each other. In an embodiment with four hoses it is possible to make the two outermost hoses considerably longer than the two innermost hoses. The outermost hoses can here be made tight over a large part or even fully, and serve to prevent lateral flowing away of the loose material mixture from the two innermost hoses, in such a way that most of the loose material settles between the two outermost hoses.

It is also possible to use a flap in the embodiment with two hoses. This is shown in Figs. 5 and 6.

The hoses 26, 27 respectively are fixed to a manifold 29, which bears a rod 30, on which the flap 31 rests, said flap extending on either side of the hoses 26 and 27.

Fig. 7 shows an embodiment in which the length of tubing is formed by a funnel 32 with a large number of elongated outflow apertures 33 in the bottom face.

From the pipe with generally circular cross section the funnel runs in cross section in an oval shape which becomes increasingly flat and wide. The cross sections VIII-VIII and IX-IX, shown in Figs. 8 and 9 respectively, show that the flat oval shape merges into a narrow outlet slit 34.

In the embodiment of Fig. 10 the funnel is also crescent-shaped in cross section, as indicated at 35, with outlet apertures 36 in the bottom part. This funnel encloses the object 37 to be covered from above.

Claims

1. Process for depositing loose material under water, in which the loose material, mixed with water, is fed in at or near the bottom of the body of water through a pipe (3) which has an outflow aperture and is directed downwards from a movable device, such as a vessel (1), while during the infeed of this mixture the device with the pipe is moved along a specific course (15), so that the outflowing mixture separates under water into water and loose material (19), the loose material being deposited on the bottom of the body of water, characterized in that, viewed in the direction of the course (15), the loose material mixture is made to flow out divided over a great length of the course through apertures (13, 22) provided in the wall of said pipe (3) near the end thereof

succeeding one another in the direction of the course, in such a way that the delivery from the pipe (3) is distributed over this great length.

2. Device for the application of the process according to claim 1, comprising a vessel (1) and a pipe (3) running downwards from the vessel (1) and having at its end an outflow mouth, characterized in that the outflow mouth comprises a length of tubing (12) which runs parallel to the bottom of the body of water and is provided with outflow apertures (13) distributed along the length of tubings (12), said apertures, possibly together with the then throttled end aperture (14) of the length of tubing (12), forming a passage which can process the delivery of the pipe (3).
3. Device according to claim 2, characterized in that the length of tubing (12) forming the outflow mouth is connected to the pipe by means of hinges (8, 9) with at least two pins standing at right angles to each other, or is itself provided with hinges with pins standing at right angles to each other, it being possible for the outflow mouth to be controlled in the desired position by external means.
4. Device according to claim 3, characterized in that the length of tubing is a rigid pipe (12).
5. Device according to Claim 2, 3 or 4, characterized in that a flap (16) is disposed on top of the length of tubing or rigid pipe (12), which flap extends on either side thereof, and the length of which is at least equal to the length of the length of tubing (12) provided with apertures (13).
6. Device according to Claim 5, characterized in that these flaps (16) on either side of the length of tubing are connected at the front and rear side by an intermediate flap (16'''), this intermediate flap (16''') being lower in height than the flap (16) to which it is connected.
7. Device according to Claim 2 or 3, characterized in that the length of tubing is a flexible hose (21) of which the part lying on the bottom has outflow apertures (22).
8. Device according to Claim 5, 6 or 7, characterized in that the length of tubing comprises two or more sections (24, 25) or hoses (26, 27) which are connected to the pipe by means of a manifold (29).

9. Device according to Claim 8, characterized in that if there are more than two hoses, the outermost hoses can be largely or fully left without lateral apertures, and the outermost hoses are longer than the innermost hoses. 5
10. Device according to one or more of the preceding Claims 2 to 9, characterized in that the apertures are disposed in the top part of the length of tubing. 10
11. Device according to one or more of the preceding Claims 2 to 10, characterized in that apertures are disposed in the bottom part of the length of tubing. 15
12. Device according to Claim 8 or 9, characterized in that a carrier (30) for a flexible flap is provided between the two or more hoses (26, 27) connected to the manifold (29). 20
13. Device according to Claim 2 or 3, characterized in that the length of tubing is in the form of a funnel (32) which from the pipe onwards has a flow cross section which increases in the direction of flow and is provided with outflow apertures (33) in the wall. 25
14. Device according to Claim 13, characterized in that the height of the funnel decreases in the direction of flow, to form an outlet slot (34) at the end of the funnel (32). 30
15. Device according to Claim 13, characterized in that the funnel passes gradually in the direction of flow from the circular cross section of the pipe to a horizontal crescent shape (35). 35
16. Device according to Claims 13, 14 or 15, characterized in that the apertures (33, 36) are disposed in the bottom wall of the funnel. 40
17. Process according to Claim 1, using the device according to one or more of the preceding Claims 2 to 16, characterized in that an elongated object such as a pipeline (15) or cable is covered. 45
18. Process according to Claim 1, using the device according to one or more of the preceding Claims 2 to 16, characterized in that a body is built up in successive paths next to and/or above each other. 50

Patentansprüche 55

1. Verfahren zum Ablagern von Schüttgut unter Wasser, bei dem das mit Wasser vermischte

Schüttgut am oder in der Nähe des Gewässergrundes durch ein Rohr (3) eingeleitet wird, das eine Ausströmöffnung aufweist und von einer beweglichen Einrichtung, z. B. einem Schiff (1), nach unten gerichtet ist, wobei die Einrichtung mit dem Rohr während des Einleitens dieser Mischung entlang eines bestimmten Kurses (15) bewegt wird, so daß unter Wasser eine Trennung der ausströmenden Mischung in Wasser und Schüttgut erfolgt, das abgelagert wird, **dadurch gekennzeichnet**, daß, in Richtung des Kurses (15) betrachtet, die Schüttgutmischung über eine große Strecke des Kurses, durch in der Wandung, nach dem Ende des Rohres (3) vorgesehene einander in Richtung des Kurses aufeinander folgende Öffnungen (13,22) separiert so ausgetragen wird, daß der Austrag aus dem Rohr (3) über diese große Strecke verteilt wird.

2. Vorrichtung zur Durchführung des Verfahrens nach Anspruch 1, mit einem Schiff (1) und einem hiervon abwärts verlaufenden an seinem Ende eine Auslaßmündung aufweisenden Rohr (3), **dadurch gekennzeichnet**, daß die Auslaßmündung ein parallel zum Gewässergrund verlaufendes Rohrstück (12) umfaßt, das mit Ausströmöffnungen (13) versehen ist, die über die Länge des Rohrstücks (12) verteilt sind und, möglicherweise zusammen mit der dann gedrosselten Endöffnung (14) des Rohrstücks (12) einen Durchfluß bilden, der den Austrag des Rohres (3) ermöglicht.

3. Vorrichtung nach Anspruch 2, **dadurch gekennzeichnet**, daß das die Auslaßmündung bildende Rohrstück (12) mit dem Rohr durch Scharniere (8, 9) mit wenigstens zwei rechtwinklig zueinander stehenden Gelenkstiften verbunden oder seinerseits mit Scharnieren mit rechtwinklig zueinander stehenden Gelenkstiften versehen ist, so daß die Auslaßmündung über externe Einrichtungen in die gewünschte Position steuerbar ist.

4. Vorrichtung nach Anspruch 3, **dadurch gekennzeichnet**, daß das Rohrstück ein starres Rohr (12) ist.

5. Vorrichtung nach Anspruch 2, 3 oder 4, **dadurch gekennzeichnet**, daß oben auf dem Rohrstück oder dem starren Rohr (12) eine Abdeckung angeordnet ist, die sich auf beiden Seiten des Rohres erstreckt, und deren Länge zumindest der Länge des mit Öffnungen (13) versehenen Rohrstücks (12) entspricht.

6. Vorrichtung nach Anspruch 5, **dadurch gekennzeichnet**, daß diese Abdeckung (16) beidseitig des Rohrstücks am vorderen und hinteren Ende durch eine Querabdeckung (16" ') miteinander verbunden sind, die eine geringere Höhe aufweist als die Abdeckung (16), mit der sie verbunden ist. 5
7. Vorrichtung nach Anspruch 2 oder 3, **dadurch gekennzeichnet**, daß das Rohrstück ein flexibler Schlauch (21) ist, dessen auf dem Grund liegender Abschnitt Ausströmöffnungen (22) aufweist. 10
8. Vorrichtung nach Anspruch 5, 6 oder 7, **dadurch gekennzeichnet**, daß das Rohrstück zwei oder mehr Abschnitte (24, 25) oder Schläuche (26, 27) aufweist, die über einen Verteiler (29) mit dem Rohr verbunden sind. 15
9. Vorrichtung nach Anspruch 8, **dadurch gekennzeichnet**, daß, wenn mehr als zwei Schläuche vorhanden sind, die äußeren Schläuche überwiegend oder völlig ohne seitliche Öffnungen ausgebildet sein können und länger sind als die inneren Schläuche. 20
10. Vorrichtung nach einem oder mehreren der vorhergehenden Ansprüche 2 bis 9, **dadurch gekennzeichnet**, daß die Öffnungen in dem oberen Teil des Rohrstücks angeordnet sind. 30
11. Vorrichtung nach einem oder mehreren der vorhergehenden Ansprüche 2 bis 10, **dadurch gekennzeichnet**, daß Öffnungen im unteren Teil des Rohrstücks angeordnet sind. 35
12. Vorrichtung nach Anspruch 8 oder 9, **dadurch gekennzeichnet**, daß zwischen den beiden oder mehreren am Rohrverteiler (29) angeschlossenen Schläuchen (26, 27) ein Halter (30) für eine flexible Abdeckung vorgesehen ist. 40
13. Vorrichtung nach Anspruch 2 oder 3, **dadurch gekennzeichnet**, daß das Rohrstück die Form eines Trichters (32) aufweist, der vom Rohr ausgehend einen sich in Strömungsrichtung vergrößernden Durchflußquerschnitt aufweist und in der Wandung mit Auslaßöffnungen (33) versehen ist. 45
14. Vorrichtung nach Anspruch 13, **dadurch gekennzeichnet**, daß die Höhe des Trichters in Strömungsrichtung abnimmt, um am Ende des Trichters (32) einen Auslaufschlitz (34) zu bilden. 55

15. Vorrichtung nach Anspruch 13, **dadurch gekennzeichnet**, daß der Trichter in Strömungsrichtung allmählich vom runden Querschnitt des Rohres in eine horizontale sichelförmige Form (35) übergeht.
16. Vorrichtung nach den Ansprüchen 13, 14 oder 15, **dadurch gekennzeichnet**, daß die Öffnungen (33, 36) in der unteren Wandung des Trichters angeordnet sind.
17. Verfahren nach Anspruch 1 unter Verwendung der Vorrichtung nach einem oder mehreren der Ansprüche 2 bis 16, **dadurch gekennzeichnet**, daß ein länglicher Gegenstand, z. B. eine Pipeline (15) oder ein Kabel bedeckt wird.
18. Verfahren nach Anspruch 1, unter Verwendung der Vorrichtung nach einem oder mehreren der Ansprüche 2 bis 16, **dadurch gekennzeichnet**, daß durch aufeinanderfolgende nebeneinander und/oder übereinander liegende Bahnen ein Körper gebildet wird.

Revendications

1. Procédé pour déposer des matériaux en vrac sous l'eau, dans lequel les matériaux en vrac, mélangés avec de l'eau, sont distribués au fond ou près du fond du corps d'eau dans un tuyau (3) qui comporte une ouverture de décharge et est dirigé vers le bas depuis un dispositif mobile, par exemple un bateau (1), tandis que durant la distribution de ce mélange, le dispositif avec le tuyau est déplacé le long d'une trajectoire spécifique (15), de manière que le mélange sortant se sépare sous l'eau en eau et matériaux en vrac (19), les matériaux en vrac étant déposés sur le fond du corps d'eau, caractérisé en ce que, dans la direction de de son trajet (15), le mélange de matériaux en vrac est amené à être déchargé divisé sur une grande longueur du trajet via des ouvertures (13, 22) ménagées dans la paroi dudit tuyau (3) près de son extrémité, se succédant dans la direction du trajet, de manière que la distribution depuis le tuyau (3) soit répartie sur cette grande longueur.
2. Dispositif pour l'application du procédé selon la revendication 1, comprenant un bateau (1) et un tuyau (3) dirigé vers le bas depuis le bateau (1), et comportant à son extrémité une ouverture de décharge, caractérisé en ce que l'ouverture de décharge comprend une longueur de tube (12) qui s'étend parallèlement au fond du corps d'eau et est dotée d'ouvertures de décharge (13) réparties le long du tube (12),

lesdites ouvertures, ainsi que l'ouverture d'extrémité (14) alors étranglée de la longueur de tube (12) formant un passage pour la décharge depuis le tuyau (3).

3. Dispositif selon la revendication 2, caractérisé en ce que la longueur de tube (12) formant l'ouverture de décharge est reliée au tuyau au moyen d'articulations (8, 9) avec au moins deux tiges perpendiculaires l'une à l'autre, ou est elle-même dotée d'articulations avec des tiges perpendiculaires l'une à l'autre, l'ouverture de décharge pouvant être contrôlée dans la position souhaitée par des moyens externes.
4. Dispositif selon la revendication 3, caractérisé en ce que la longueur de tube est un tube rigide (12).
5. Dispositif selon la revendication 2, 3 ou 4, caractérisé en ce qu'un volet (16) est disposé sur le dessus de la longueur de tube ou tube rigide (12), lequel volet s'étend de chaque côté de celui-ci, et la longueur du volet étant au moins égale à la longueur de tube (12) doté des ouvertures (13).
6. Dispositif selon la revendication 5, caractérisé en ce que ces volets de chaque côté de la longueur de tube sont reliés à l'avant et à l'arrière par un volet intermédiaire (16'''), ledit volet intermédiaire (16''') étant moins haut que le volet (16) auquel il est relié.
7. Dispositif selon la revendication 2 ou 3, caractérisé en ce que la longueur de tube est un tube flexible (21) dont la partie reposant sur le fond comporte des ouvertures de décharge (22).
8. Dispositif selon la revendication 5, 6 ou 7, caractérisé en ce que la longueur de tube comprend deux sections (24, 25) ou tubes (26, 27) ou davantage qui sont reliés au tuyau au moyen d'un collecteur (29).
9. Dispositif selon la revendication 8, caractérisé en ce que si plus de deux tubes sont utilisés, les tubes les plus à l'extérieur peuvent être laissés pratiquement ou complètement sans ouvertures latérales, et les tubes les plus à l'extérieur sont plus longs que les tubes les plus à l'intérieur.
10. Dispositif selon l'une ou plusieurs des revendications précédentes 2 à 9, caractérisé en ce que les ouvertures sont disposées dans la partie supérieure de la longueur de tube.

11. Dispositif selon l'une ou plusieurs des revendications précédentes 2 à 10, caractérisé en ce que les ouvertures sont disposées dans la partie inférieure de la longueur de tube.

12. Dispositif selon la revendication 8 ou 9, caractérisé en ce qu'un support (30) pour volet flexible est disposé entre les deux tubes (26, 27) ou davantage reliés au collecteur (29).

13. Dispositif selon la revendication 2 ou 3, caractérisé en ce que la longueur de tube a la forme d'un entonnoir (32) qui depuis le tube en avant présente une section transversale d'écoulement qui augmente dans la direction de l'écoulement et est doté d'ouvertures de décharge (33) dans la paroi.

14. Dispositif selon la revendication 13, caractérisé en ce que la hauteur de l'entonnoir diminue dans la direction de l'écoulement, pour former une fente de sortie (34) à l'extrémité de l'entonnoir (32).

15. Dispositif selon la revendication 13, caractérisé en ce que l'entonnoir passe progressivement dans la direction de l'écoulement de la section transversale circulaire du tuyau à une forme de croissant horizontal (35).

16. Dispositif selon la revendication 13, 14 ou 15, caractérisé en ce que les ouvertures (33, 36) sont disposées dans la paroi inférieure de l'entonnoir.

17. Procédé selon la revendication 1, utilisant le dispositif selon l'une ou plusieurs des revendications précédentes 2 à 16, caractérisé en ce qu'un objet allongé tel qu'une conduite (15) ou un câble est recouvert.

18. Procédé selon la revendication 1, utilisant le dispositif selon l'une ou plusieurs des revendications précédentes 2 à 16, caractérisé en ce qu'un corps est accumulé par passages successifs près les uns des autres et/ou au-dessus les uns des autres.

fig-1

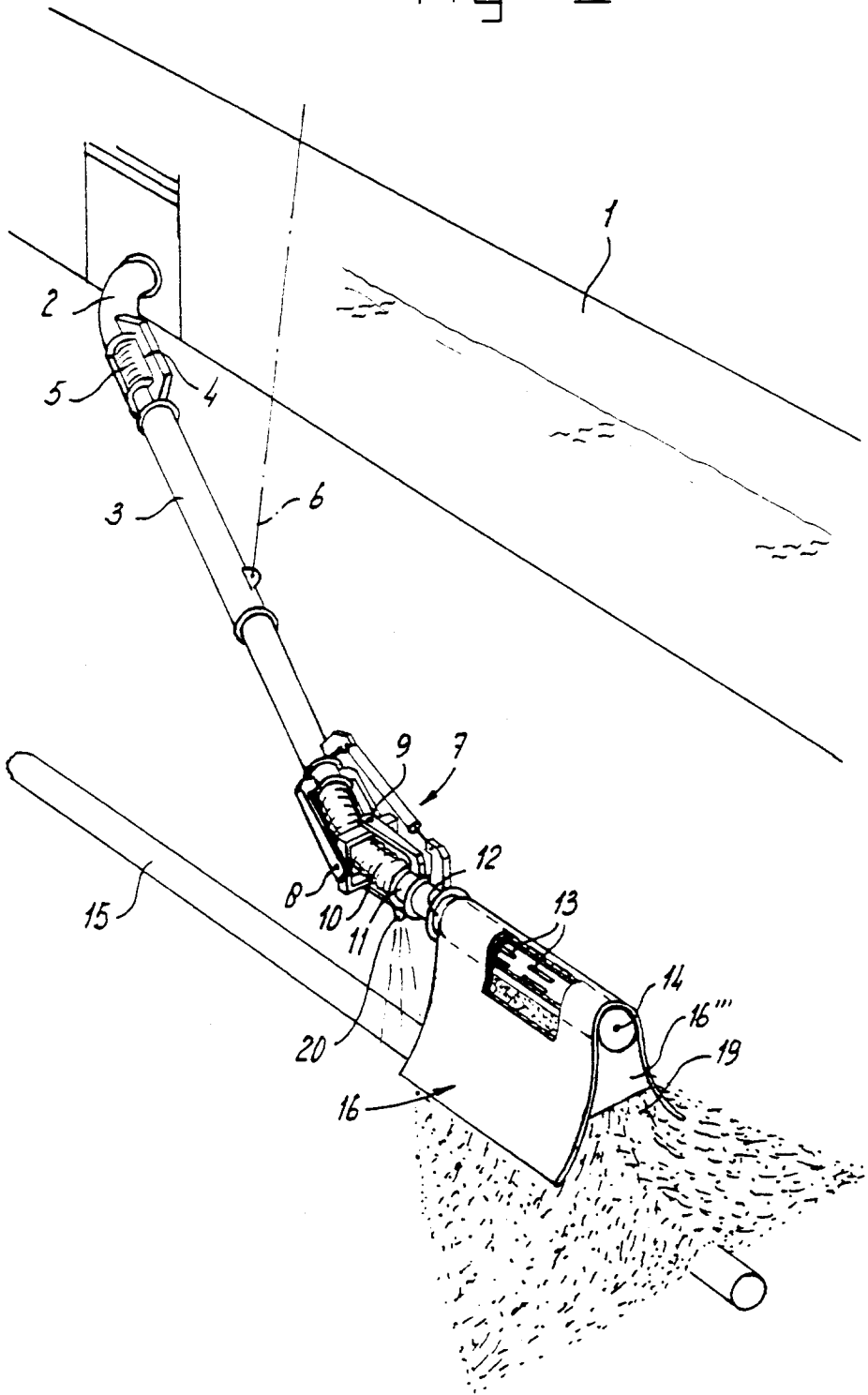

fig-2

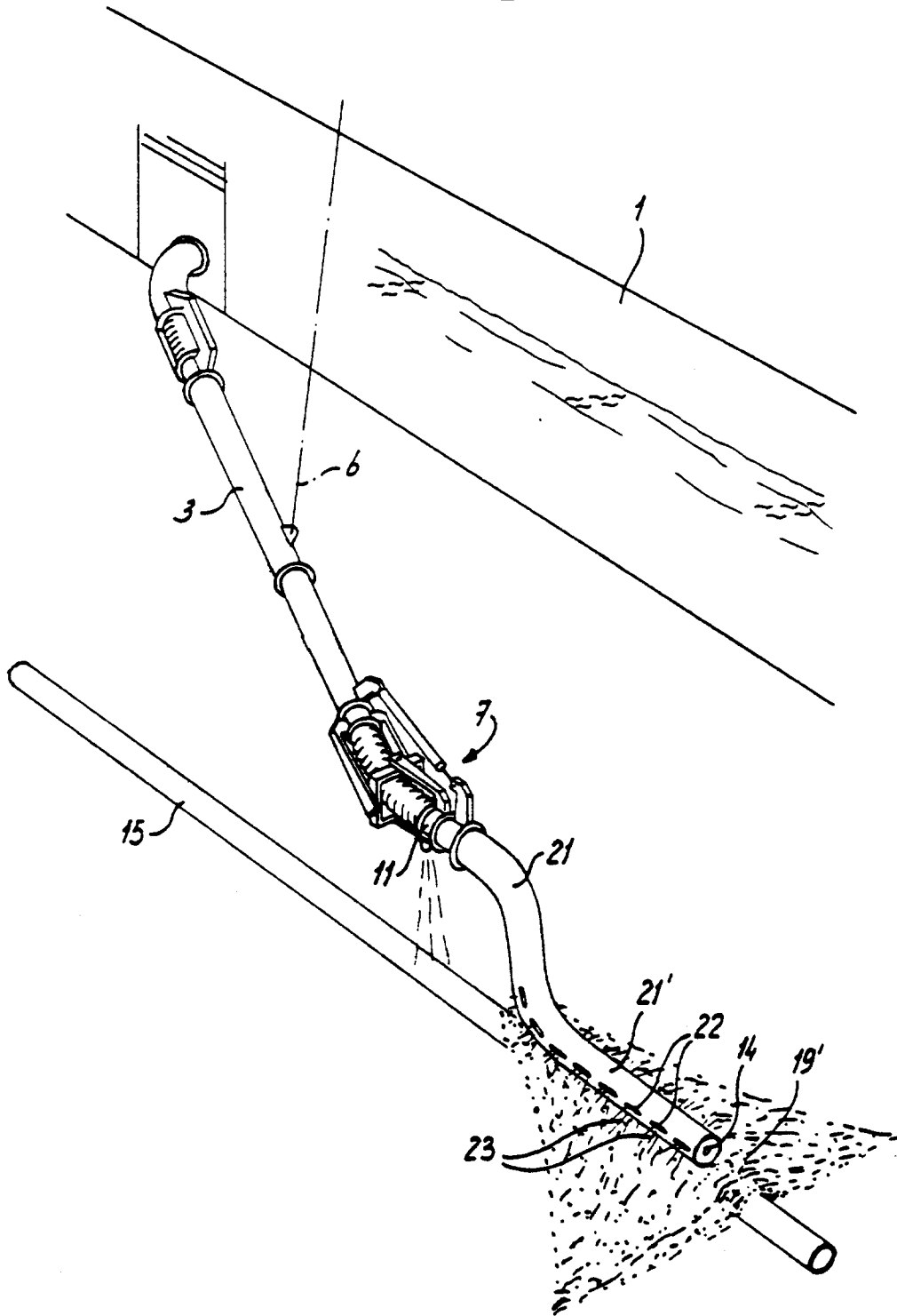

fig-3

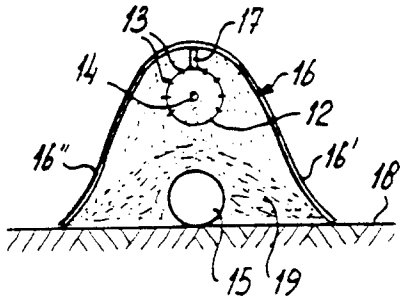

fig-4

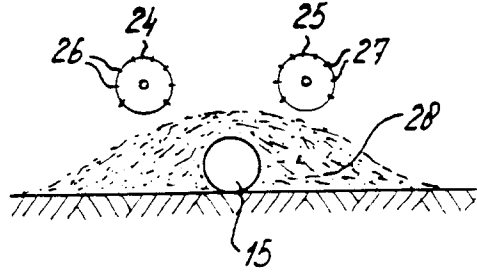

fig-5

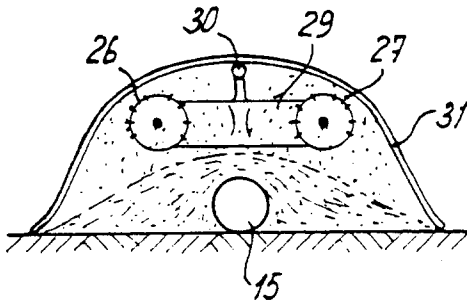

fig-6

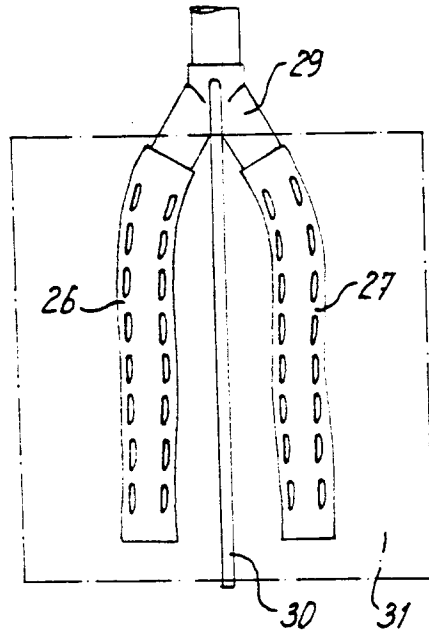

fig-7

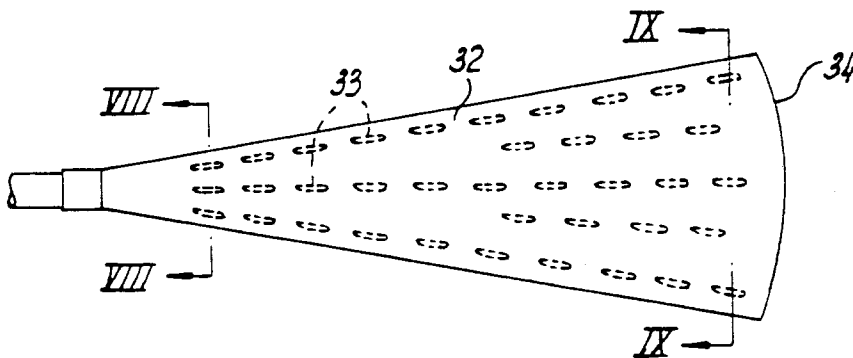

fig - 8

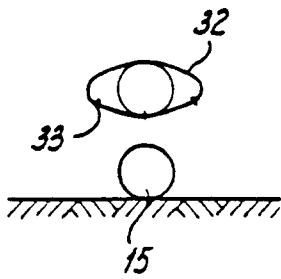

fig - 9

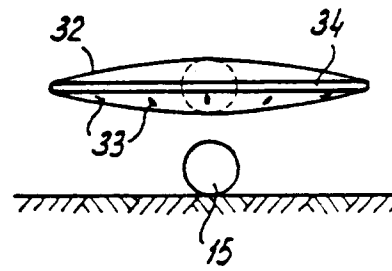

fig - 10

