

(No Model.)

2 Sheets—Sheet 1.

C. G. ZEILMAN.
CISTERN FOR WATER CLOSETS.

No. 444,310.

Patented Jan. 6, 1891.

Fig. 2.

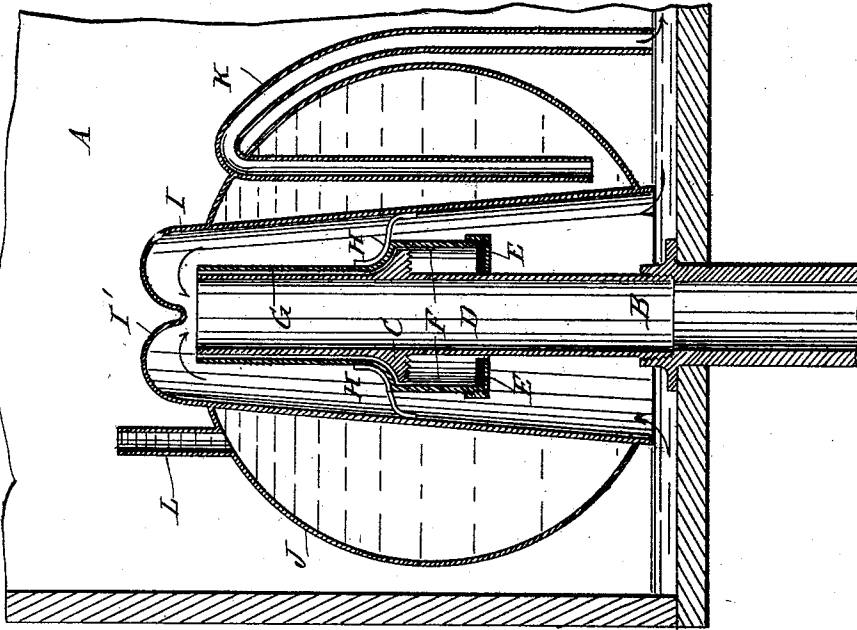
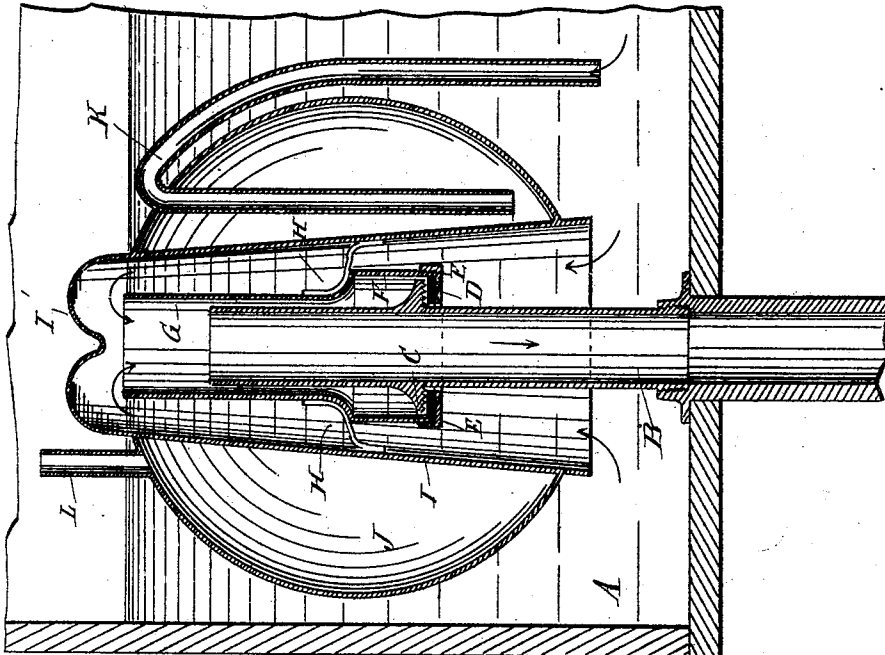

Fig. 1.



WITNESSES:

Chas. Nida
C. Sedgwick

INVENTOR:

C. G. Zeilman

BY

Munn & Co

ATTORNEYS

(No Model.)

2 Sheets—Sheet 2.

C. G. ZEILMAN.
CISTERN FOR WATER CLOSETS.

No. 444,310.

Patented Jan. 6, 1891.

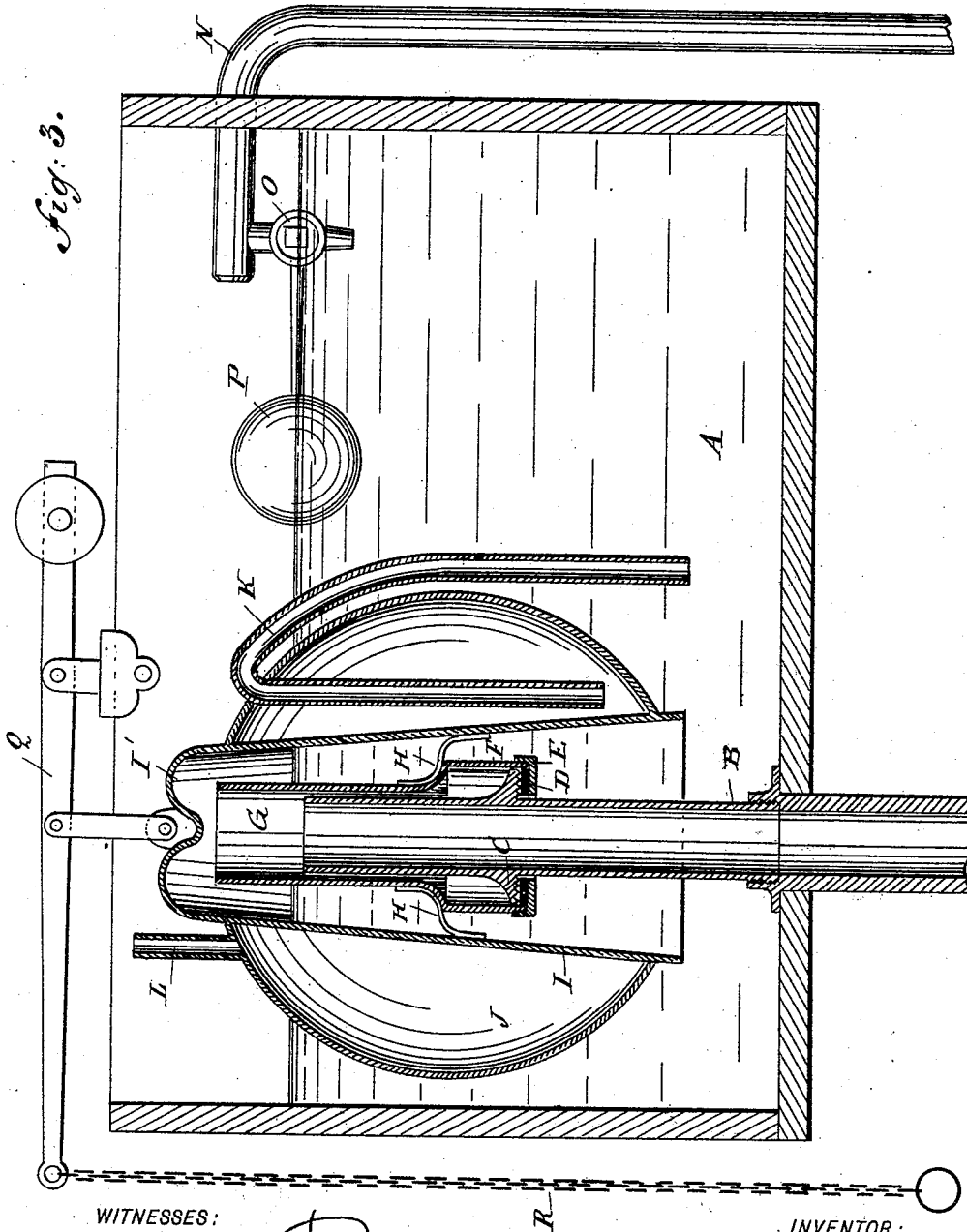

WITNESSES:
Chas. Nida
S. Sedgwick

INVENTOR:
C. G. Zeilman
 BY
Munn & Co
 ATTORNEYS

UNITED STATES PATENT OFFICE.

CHARLES G. ZEILMAN, OF ALBANY, NEW YORK.

CISTERN FOR WATER-CLOSETS.

SPECIFICATION forming part of Letters Patent No. 444,810, dated January 6, 1891.

Application filed May 7, 1890. Serial No. 350,889. (No model.)

To all whom it may concern:

Be it known that I, CHARLES G. ZEILMAN, of Albany, in the county of Albany and State of New York, have invented a new and Improved Cistern for Water-Closets, of which the following is a full, clear, and exact description.

The object of the invention is to provide a new and improved cistern, which is simple and durable in construction, very sensitive, effective, and positive in operation, and which prevents all leakage and overflow and consequent flooding of the building in which the cistern is located.

The invention consists of certain parts and details and combinations of the same, as will be hereinafter fully described and then pointed out in the claims.

Reference is to be had to the accompanying drawings, forming a part of this specification, in which similar letters of reference indicate corresponding parts in all the figures.

Figure 1 is a sectional side elevation of the improvement with the cistern filled. Fig. 2 is a like view of the same in the lowermost position, the cistern being almost empty; and Fig. 3 is a sectional side elevation of a modified form of the improvement.

The device as shown in Figs. 1 and 2 is intended to be entirely automatic, while the device illustrated in Fig. 3 is non-automatic and under the control of the operator, so as to discharge the tank whenever occasion requires it.

The cistern A, of suitable size, is provided with the usual vertically-arranged overflow-pipe B, provided near its upper end and on the outside with a corrugated annular stop C, on which is adapted to be seated a packing D, held on a flange on a screw-cap E, screwing on a pipe F, supporting on its upper end a pipe G, fitted to slide on the outside of the upper end of the said overflow-pipe B. The lower end of the pipe G is slightly bell-shaped and is adapted to engage the top of the stop C, so that the movements of the pipes F and G are limited by the packing D striking the under side of the stop C when the said pipes are in an uppermost position, and the lower bell-shaped end of the pipe G resting on the top of the stop C when the pipes are

in the lowermost position, as illustrated in Fig. 2. When the pipe G is in an uppermost position, as illustrated in Fig. 1, its upper end extends a suitable distance above the upper end of the overflow-pipe B, and when the said pipe is in a lowermost position, as shown in Fig. 2, the upper ends of the pipes G and B are even. The pipe G is connected by a series of braces H with the pipe I, surrounding the pipe G, and the pipe I is open at the bottom and is closed at the top by a suitable cap I', extending a short distance above the upper end of the pipe G. Around this pipe I is fitted a hollow float J, into which opens one arm of the siphon K, the other arm of which extends into the cistern A—that is, into the water contained in the latter. From the upper end of the float J leads an air-outlet pipe L, reaching above the water-level in the cistern.

The operation is as follows: When the tank is almost empty and the float J is discharged, then the several parts are in a lowermost position, so that when the cistern now fills with water in the usual manner, the float J rises until the packing D seats itself on the stop C. The overflow-pipe B is now extended by the upper end of the pipe G, as is plainly shown in Fig. 1, so that the cistern can be still charged with water to a level reaching above the upper end of the overflow-pipe B. When the water-level is above the upper end of the siphon K, as shown in Fig. 1, then the water from the cistern A passes through the outer arm of the siphon into the float J, so as to fill the same, the air in the latter being displaced by the incoming water and discharged through the outlet L. As the float J is filled with the water, it becomes heavier than the water displaced by the float, so that the latter settles into its lowermost position, (shown in Fig. 2,) whereby the upper end of the pipe G is flush with the upper end of the overflow B. The said extension overflow-pipe G is now lowered and the water in the cistern passes over the upper ends of the pipes G and B and down the latter, to be discharged in the usual manner. It will be seen that nearly all the water in the cistern A is discharged through the overflow B, as the water is siphoned by the pipe I. As soon as the water in the cistern

A is lower than the float—that is, the lower end of the pipe I—then the float is emptied of its water by the siphon K discharging the water of the float into the cistern. When the cistern is again filled with water, the above-described operation is repeated. Thus it will be seen that the water in the cistern A is automatically discharged whenever a predetermined quantity of water has accumulated in the cistern. It will further be seen that the device is entirely automatic in operation, is very sensitive, and consequently prevents overflowing of the cistern and flooding of the building in which the latter is located.

The device shown in Fig. 3 is applied to a cistern A, having an inlet-pipe N, provided with the usual valve O, controlled by a float P, which shuts the valve whenever the water in the cistern reaches a certain level. The cap I' of the pipe I is pivotally connected by a link with a weighted lever Q, carrying at its free end a rope or chain R, adapted to be taken hold of by the operator and pulled whenever it is desired to discharge the cistern.

When the device is in the normal position, as shown in Fig. 3, and the supply is shut off by the action of the float P on the valve O, the siphon-pipe K extends with its top above the water-level. When the operator pulls on the chain R, the pipe I, the float J, and siphon K move downward, so that the upper end of pipe G is flush with the upper end of the overflow B, and the water in the cistern passes into the latter to be discharged. By this arrangement the device is non-automatic.

Having thus fully described my invention, I claim as new and desire to secure by Letters Patent—

1. In a cistern for water-closets, the combi-

nation, with a pipe fitted to slide on a stationary overflow-pipe to form an extension thereof, of a float supported on the said pipe and a siphon held on the said float to charge and to empty the latter, substantially as shown and described.

2. In a cistern for water-closets, the combination, with a fixed overflow-pipe, of a pipe fitted to slide on the said overflow-pipe, a float provided with a pipe surrounding the said extension-pipe and supported from the latter and having a closed top and an open bottom, substantially as shown and described.

3. In a cistern for water-closets, the combination, with a fixed overflow-pipe, of a pipe fitted to slide on the said overflow-pipe, a float provided with a pipe surrounding the said extension-pipe and supported from the latter and having a closed top and an open bottom, and a siphon connected with the said float to charge and empty the same automatically, substantially as shown and described.

4. In a cistern for water-closets, the combination, with a fixed overflow-pipe, of a pipe fitted to slide on the said overflow-pipe, a stop to limit the movement of the said sliding pipe, a float provided with a pipe surrounding the said extension-pipe and supported from the latter and having a closed top and an open bottom, a siphon connected with the said float to charge and empty the same automatically, and an air-outlet pipe arranged on the top of the said float to discharge and admit air when the float is charged and emptied by the said siphon, substantially as shown and described.

CHARLES G. ZEILMAN.

Witnesses:

GEORGE NOYES,
J. A. SCHILLING.