

Sept. 3, 1940.

L. W. VAN BUSKIRK

2,213,925

DIPPER TOOTH

Filed Nov. 4, 1938

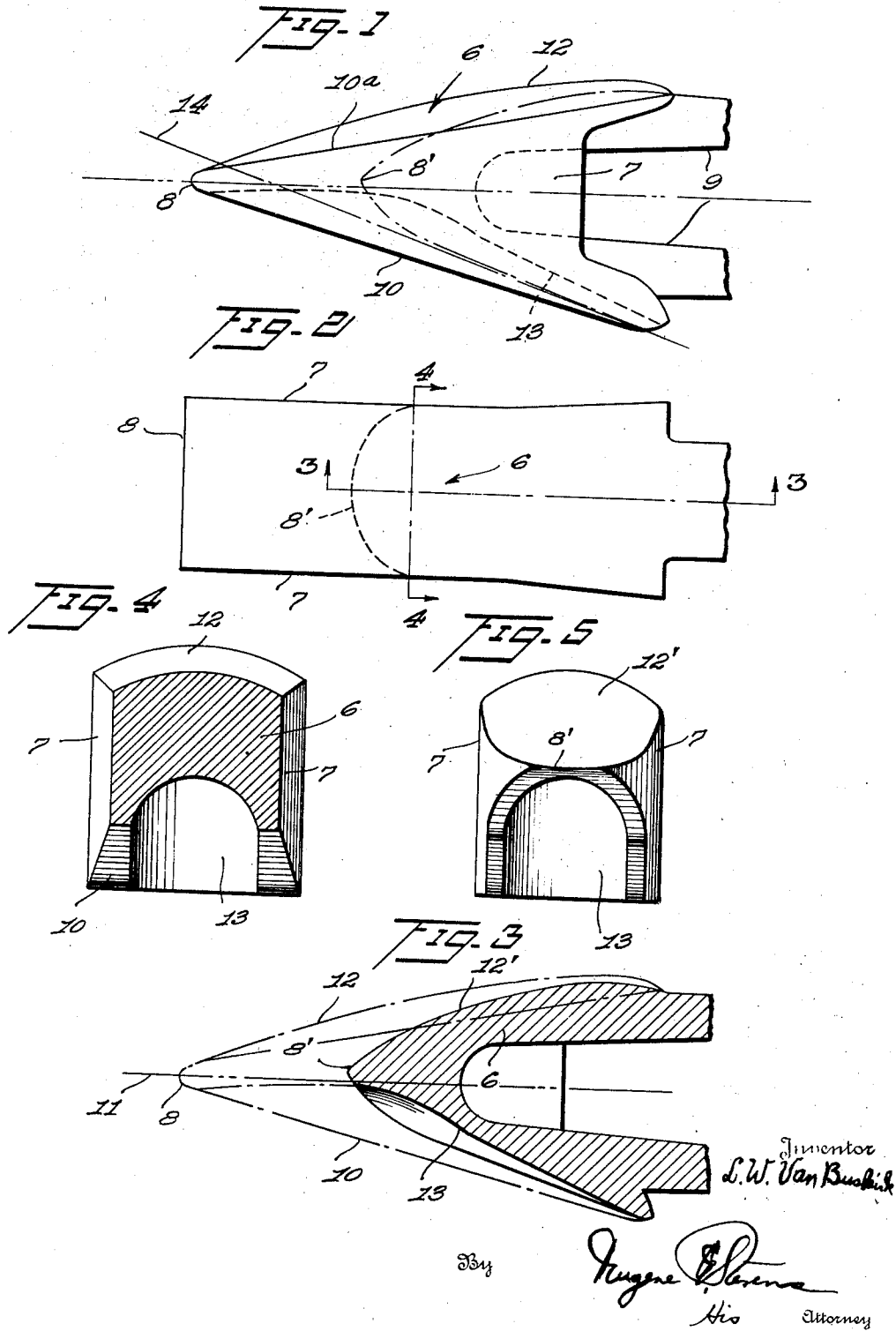

UNITED STATES PATENT OFFICE

2,213,925

DIPPER TOOTH

Leshner W. Van Buskirk, Easton, Pa.

Application November 4, 1938, Serial No. 238,865

6 Claims. (Cl. 37—142)

This invention relates to dipper teeth for power shovels and the like and in particular to wear points therefor, which usually are formed as renewable elements.

5 In service, the maximum wear on the point of a dipper tooth occurs at its front, and as the tooth is customarily a solid wedge shaped body the point soon becomes dulled and blunt. Attempts have been made to provide for a self-sharpening action as the tooth wears by providing recesses in both the upper and lower tooth faces so that a reduced thickness of metal is constantly presented at the front as the tooth wears away. While such a construction is effective in presenting a point, it becomes increasingly susceptible to curling or distortion due to the inherent weakness resulting from the lack of reinforcement which is a concomitant of the recessing.

20 An object of the present invention is to provide a self-sharpening dipper tooth point having, at all stages of wear, adequate reinforcement against curling or distortion, so that the point efficiency is maintained and the point is inhibited against curling or distortion over the entire wear life of the tooth.

25 Another object is to provide a tooth wear point which, in addition to possessing the above characteristics, becomes progressively arcuate at its wear edge in the transverse axial plane of the tooth as it wears away.

30 Still another object is to provide a dipper tooth having a self-sharpening point whereof the apex remains substantially in the transverse axial plane of the tooth and at substantially the same angle of incidence with respect to its ground line over the entire wear life of the point.

35 An additional object is the provision of a self-sharpening dipper tooth having an axially grooved under face and an upper face proportionately elevated to compensate the decrease in thickness caused by the formation of the groove.

40 Other objects will be readily apparent to those skilled in the art.

In the accompanying drawing:

45 Figure 1 is an elevation, in full lines, of a tooth as formed in accordance with the invention, and showing in broken line the shape of the tooth at an intermediate stage of its wear.

50 Figure 2 is a top plan view of the tooth, illustrating in dotted line the arcuate curvature of the point when worn to the intermediate stage noted in Figure 1.

55 Figure 3 is an axial section on the line 3—3 of

Fig. 2, illustrating in broken line the contour of the tooth prior to service, and in full line the shape of the tooth at the intermediate wear stage noted in Figures 1 and 2.

Figure 4 is a transverse section on the line 4—4 of Figure 2.

Figure 5 is a front end elevation of the tooth point at the intermediate wear stage noted in Figures 1, 2 and 3.

In the disclosed embodiment of the invention my improved tooth comprises a body 6 having substantially straight sides 7 and a straight front or wear edge 8 extending transversely between the sides, its rear edge portion being bifurcated in the usual manner to provide arms 9 by which the tooth is secured to its support, not shown.

In side elevation the tooth is substantially wedge-shaped, having its under face, or ground line 10, in a plane convergent with respect to the transverse axial plane 11 of the body and intersecting said axial plane substantially at the apex of the wear point which, prior to service, coincides with the front edge 8 as shown in Figure 1. In this respect the tooth follows conventional practice.

25 At its upper face or top the tooth departs from conventional practice which, in the case of a solid tooth, usually embodies a flat top face in a plane coincident with the line 10a of Figure 1 which is convergent to the axial plane 11. In my improved form of tooth the entire top face 12 is crowned transversely and curved arcuately from front to rear in the axis of the tooth. This arrangement provides for an integral increased thickness of metal over the entire top face of the tooth. The under face of the tooth beginning at or near the front edge wear point 8 is formed with a recess or channel 13 which extends axially of the tooth being arcuate with respect to a transverse plane passed through the tooth and being also substantially arcuate with respect to the axis of the tooth. The recess or channel 13 constitutes a groove in the under face of the tooth which runs from the front edge thereof entirely to the rear of the tooth body. The major depth of the groove 13 occurs substantially at the mid-section of the tooth and proximate the axis thereof. From its point of greatest depth forwardly the groove is arcuate in the axial plane of the tooth while from that point rearwardly the grooved bottom assumes substantially a straight line to the rear end of the tooth, as will be evident from the illustration of Figure 1.

Figure 1 illustrates in broken line contour the configuration of the tooth when it has worn back

to the approximate mid-section. It will be seen that the wear point 8' remains substantially at the transverse axial plane 11 of the tooth, the ground bearing line being defined by the straight line portion of the bottom of the groove 13 which is convergent to the tooth axis 11 at the wear point 8' at substantially the same angle at which the initial ground line 10 is convergent to the axis 11 at the initial wear point 8. It should be remembered that as the tooth wears back the sides of the tooth wear away progressively so that the side walls of the groove 13 become progressively thinner and form, in effect, thin vertical cutting edges which play merely a negligible part in determining the ground bearing line of the tooth as they present insufficient horizontal surface to support the tooth body.

If the tooth were of the conventional solid type with no groove in its bottom face the ground bearing line would lie in the plane 14 when the tooth had worn back to the intermediate point 8'. It is evident that the ground bearing line in such case would be convergent to the tooth axis at a point spaced considerably in advance of the wear point 8', the effect being to dispose the point 8' considerably above the plane of the ground bearing line so that as the tooth moved forward the elevated point would not bite into the material being excavated but on the contrary would tend to slide up on the material and thus lift the tooth without obtaining proper entry into the body of the material being excavated. In like manner the point would correspondingly become increasingly elevated as the tooth wore back so that the tooth would become entirely ineffective.

Further with reference to Figure 1 it will be noted that at the wear point 8' the ground bearing line, being in the plane of the groove bottom 13, intersects the tooth axis substantially at the apex of the wear point so that the point rests on the ground as the tooth moves forward and at the proper angle for maximum entrance efficiency. This disposition of the wear point is effected automatically as the tooth progressively wears back and it is well illustrated in Figure 3, it being remembered that the vertical side walls of the groove are at such point merely thin substantially knife-like cutting edges. These edges thus penetrate the material to be dug.

It is thus evident that as the tooth wears back the wear point will be self-sharpening so that the maximum efficiency of the tooth is obtained over its entire life of wear.

An important feature of the invention resides in the fact that due to the crowning of the tooth over its top face 12, a sufficient thickness of metal is presented to provide adequate reinforcement resisting any tendency of the point to curl up or become distorted, and adds life to the sharp cutting tooth. As the high point of the crown over the top face 12 coincides with a vertical plane passed through the axis of the tooth, which plane also coincides with the bottom of the groove 13 in the underface, it is evident that the maximum thickness of reinforcing metal over the top face of the tooth occurs axially of the tooth in the line of greatest strain to which the wear point is subjected. This is well shown in Figure 5 in connection with Figure 2 wherein it is evident that when the tooth has worn back to the wear point 8' the cutting edge of the point is curved transversely of the tooth presenting an elliptical cutting edge which becomes progressively of increased curvature as the tooth wears

back. Thus, not only is the tooth automatically self-sharpening with respect to a vertical plane but with respect to a transverse axial plane, the combined effect of the two self-sharpening actions together with the presence of the groove 13 giving the precise self-sharpening action and form of an animal's claw.

A feature of the invention resides in the fact that the progressive rearward elevation of the top face 12 increases in proportion to the decrease in thickness of the lower half of the tooth caused by the formation of the groove 13. Otherwise expressed, in form and location, the mass of the tooth body removed in providing the groove 13 is substantially transferred to and superimposed upon the top face 12, the maximum altitude of crowning occurring substantially at the mid-section of the tooth, at which point the groove 13 has substantially the greatest depth.

While in this illustrated embodiment I have disclosed a preferred form of the invention, it is understood that within the scope of the invention as claimed, the structural details and arrangement of parts may be varied as desired and substituted by any suitable equivalent.

I claim:

1. A dipper tooth comprising a body having a wear point at its front edge and extending transversely of the body, said body having substantially flat sides perpendicular to the wear point at the front of the body, the top and bottom faces of said body being divergent rearwardly from said wear point, said bottom face having formed therein an axially extending groove of arcuate form transversely of the body, and the top face of said body being integrally elevated as a crown extending from the wear point to the rear edge of the body with its major height in the axis of the body at substantially its mid-section, the mass of the elevated portion of said top face being substantially equal in bulk and location to the mass of the body removed in forming said groove.

2. A dipper tooth comprising a substantially wedge shaped body provided on its under face with an axially extending groove of substantially arcuate cross section, and the upper face of said body being integrally thickened rearwardly substantially in proportion to the decrease of thickness at the under face resulting from the provision of the groove.

3. A dipper tooth comprising a wedge shaped body having on its under face an axially extending recess of substantially arcuate cross section and extending at its sides to within a short distance of the sides of the body, and the upper face of said body being crowned transversely and axially substantially in proportion to the decrease of thickness at the underface resulting from the provision of the groove.

4. A dipper tooth comprising a substantially wedge shaped body having an axially disposed groove in its under face, the major depth of said groove being substantially at the mid-section of said body, and the top face of said body being integrally elevated in the axis of the body substantially in proportion to the decrease in thickness of the lower face caused by the formation of said groove.

5. A dipper tooth comprising a substantially wedge shaped body having an axially disposed groove in its under face, the major depth of said groove being substantially at the mid-section of the body, and the top face of the body being of

greater thickness over substantially the mid-section of the body than at any other point.

5 6. A dipper tooth comprising a substantially wedge shaped body provided on its under face with an axially extending groove, and the upper portion of the body being progressively thickened

axially and rearwardly of the tooth in proportion to and in conformity with the shape and depth of the groove, said groove extending substantially in parallelism to the thickened portion of the body.

LESHER W. VAN BUSKIRK. 5