



US 20080245752A1

(19) **United States**  
(12) **Patent Application Publication**  
**Isserstedt**

(10) **Pub. No.: US 2008/0245752 A1**  
(43) **Pub. Date: Oct. 9, 2008**

(54) **DISC STORAGE SYSTEM**

(30) **Foreign Application Priority Data**

(76) Inventor: **Robert Kurt Isserstedt**, Aldsworth  
Close (GB)

Feb. 18, 2004 (GB) ..... 0403619.0

**Publication Classification**

Correspondence Address:

**Allen R Kipnes**  
**Watov & Kipnes**  
**P O Box 247**  
**Princeton Junction, NJ 08550 (US)**

(51) **Int. Cl.**  
**B65D 85/57** (2006.01)

(52) **U.S. Cl.** ..... 211/13.1; 206/308.1

(57) **ABSTRACT**

A disc storage system comprising a plurality of plastic pouches arranged to be stored on a storage device having two parallel elongate storage elements. The pouches are provided with an opening for receiving a disc and apertures arranged to engage with the parallel elongate storage elements such that the pouch can be located on and removed from the storage device.

(21) Appl. No.: **10/589,706**

(22) PCT Filed: **Feb. 18, 2005**

(86) PCT No.: **PCT/GB05/00584**

§ 371 (c)(1),  
(2), (4) Date: **Sep. 7, 2007**

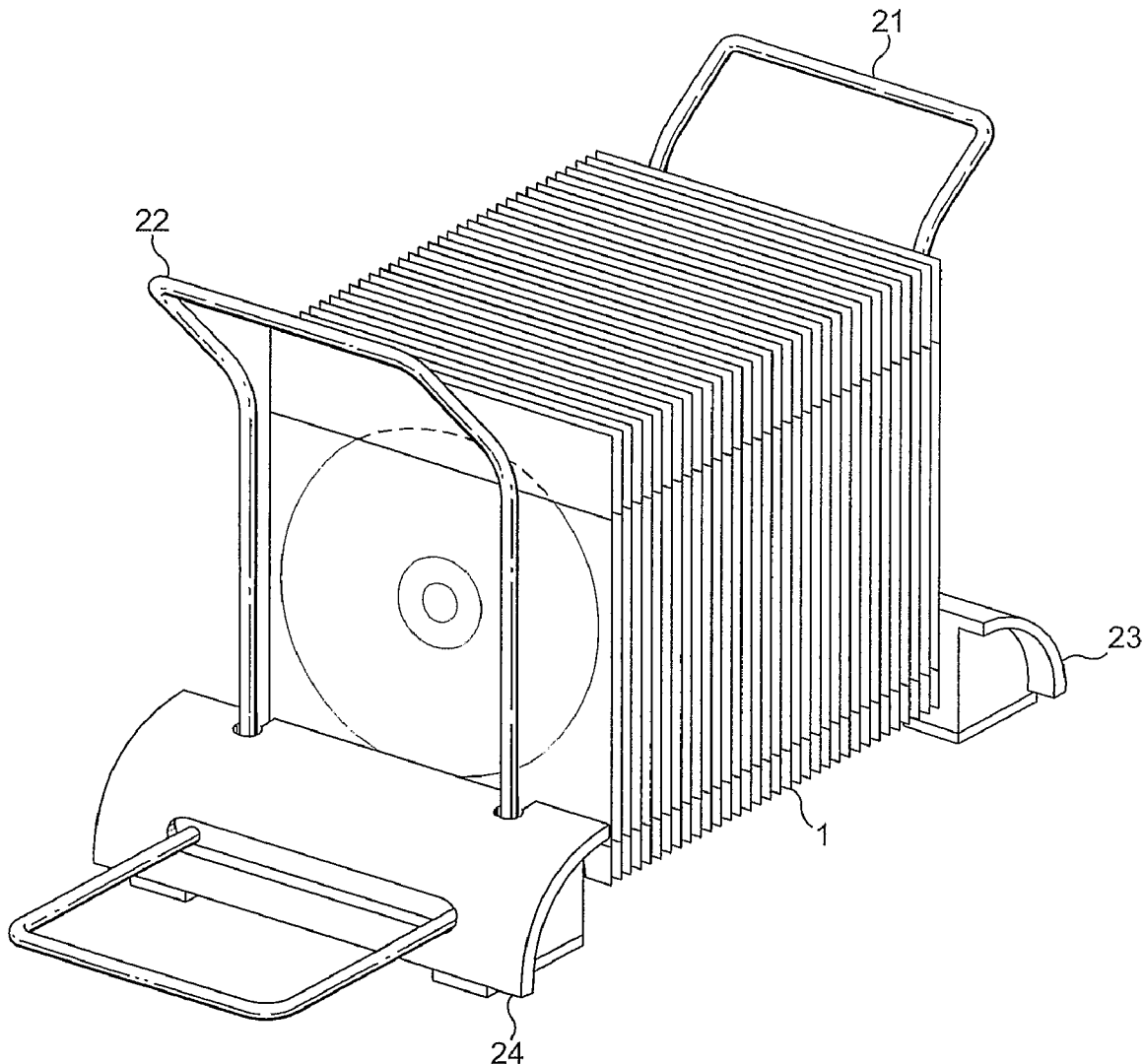

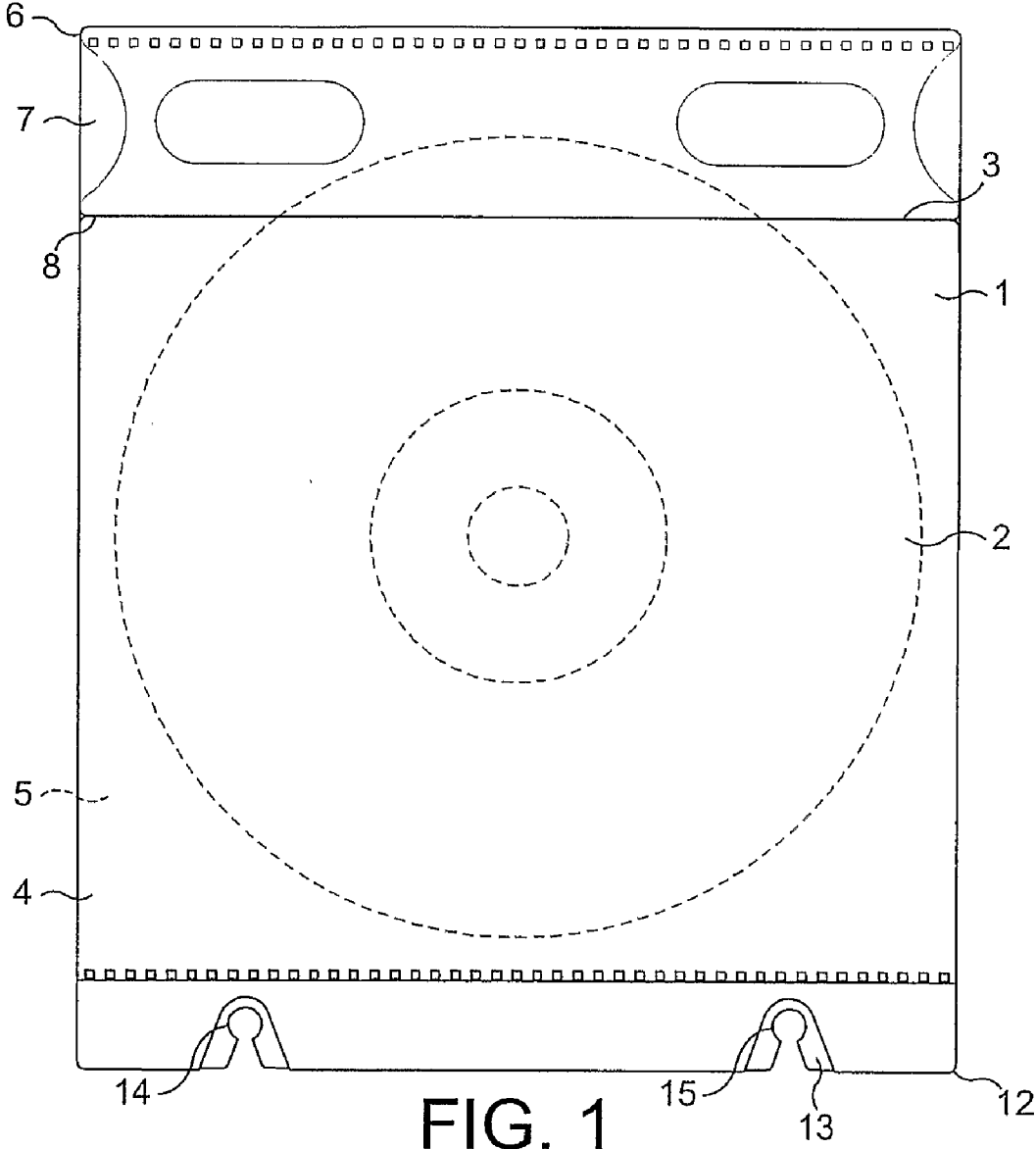

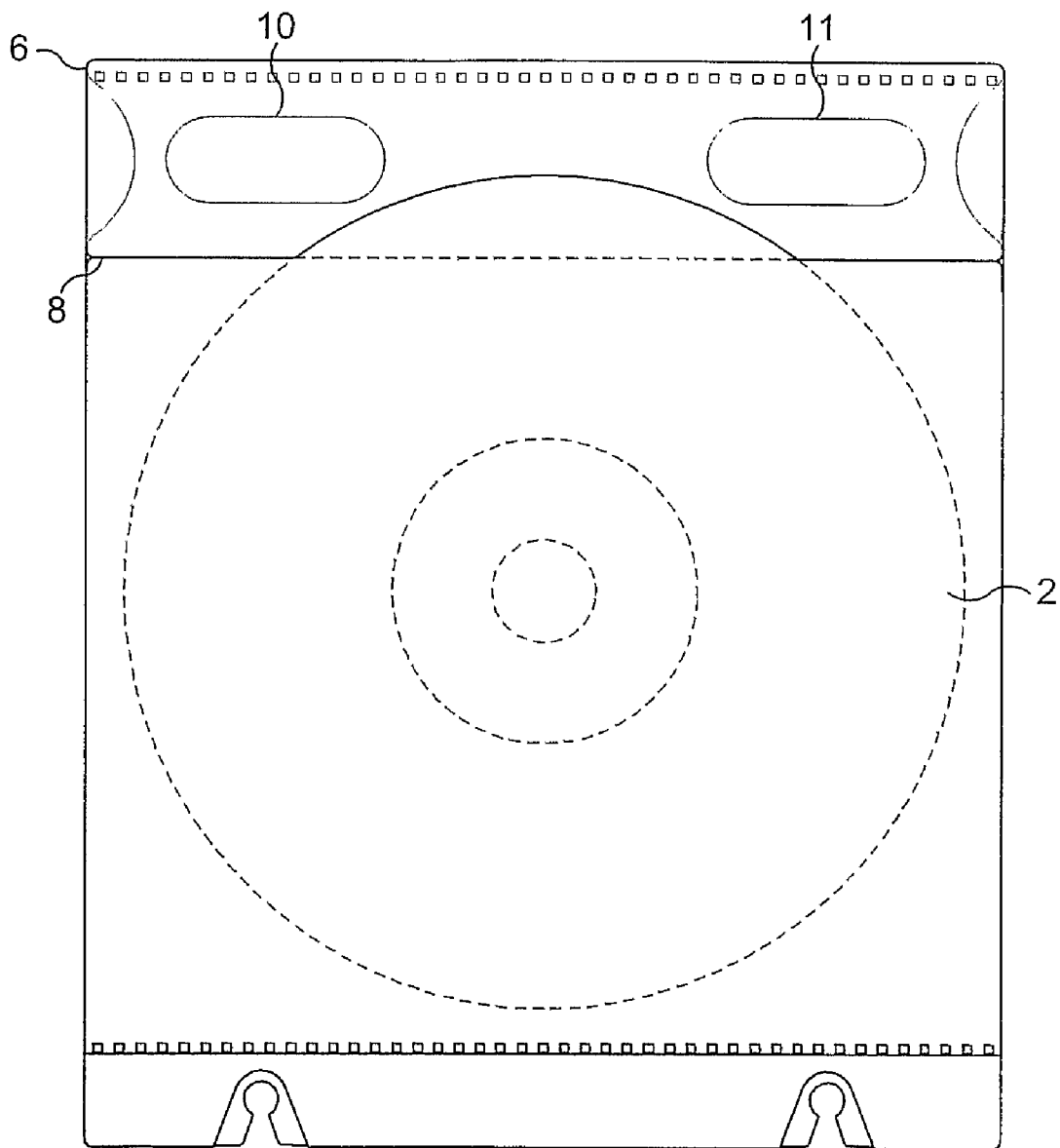

FIG. 2

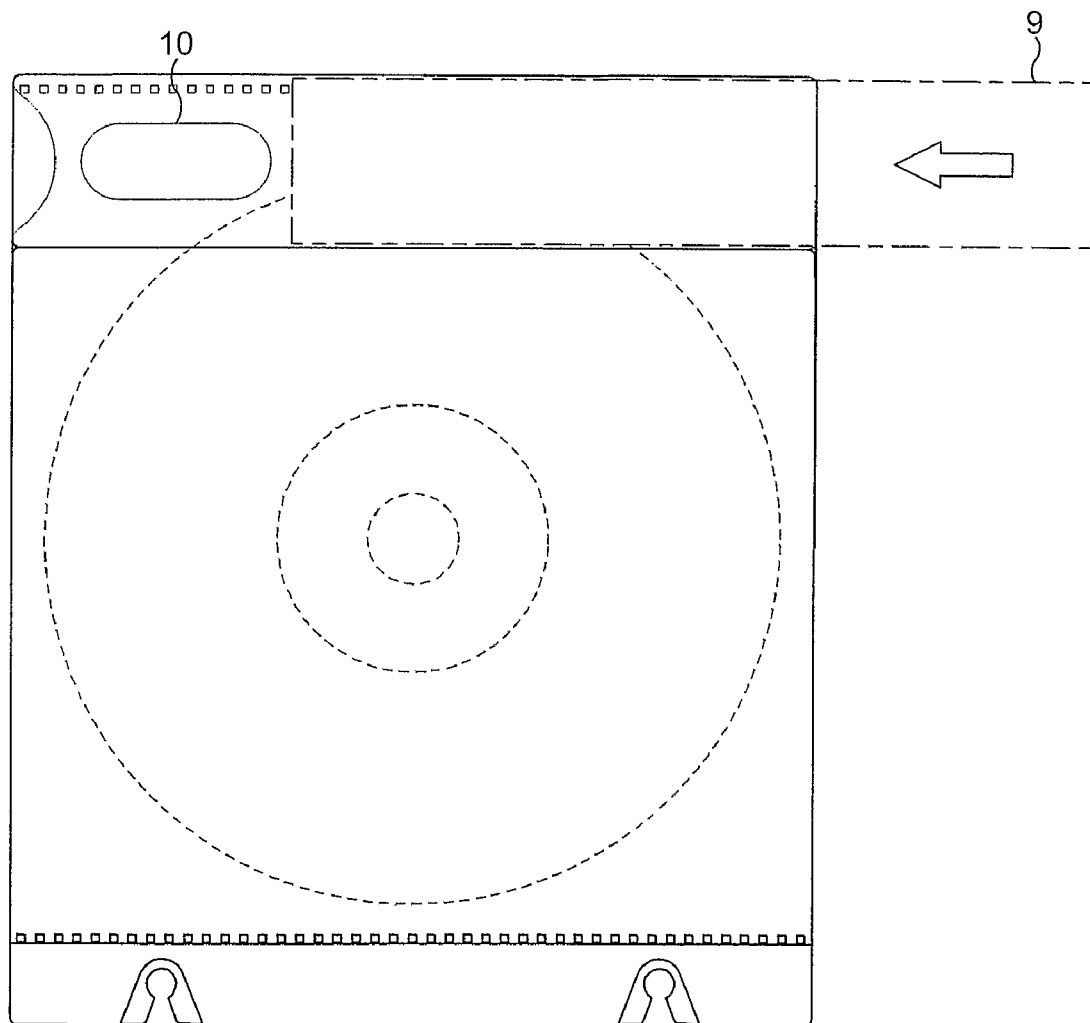

FIG. 3

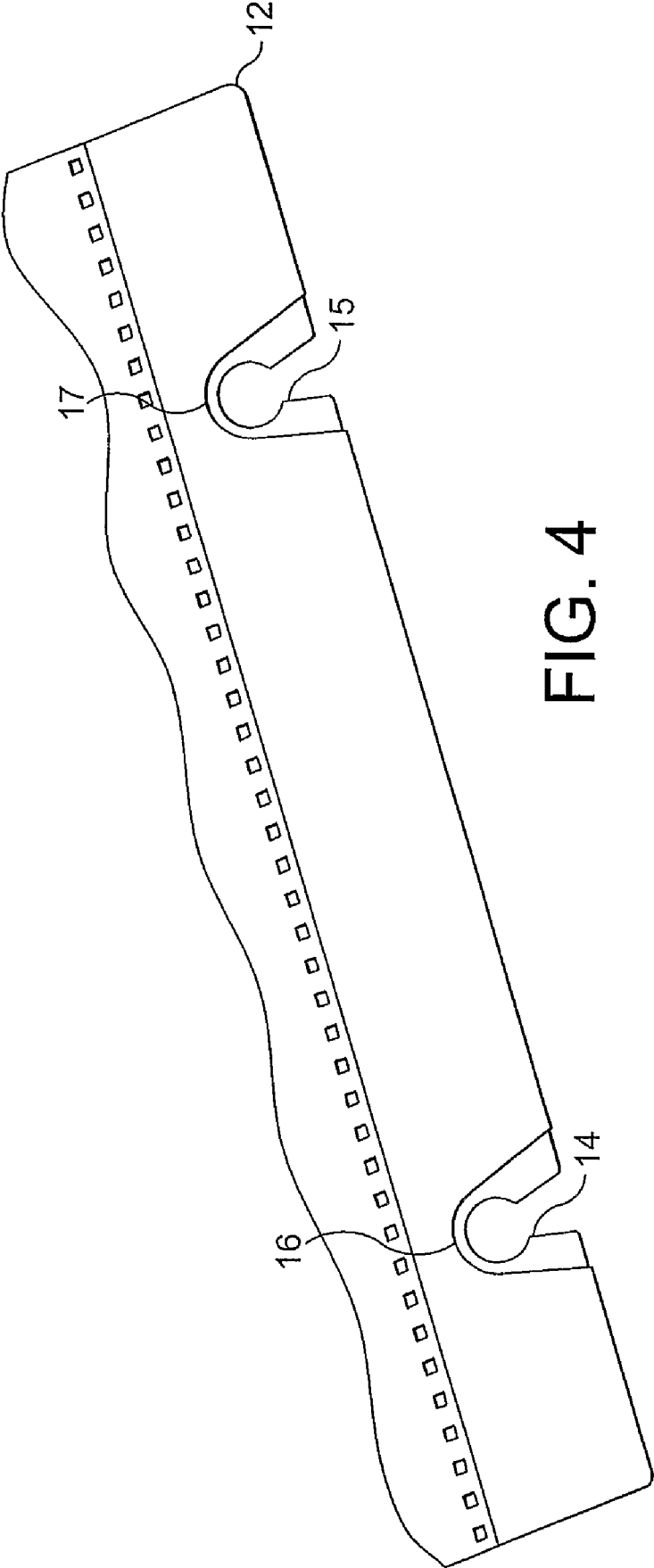

FIG. 4

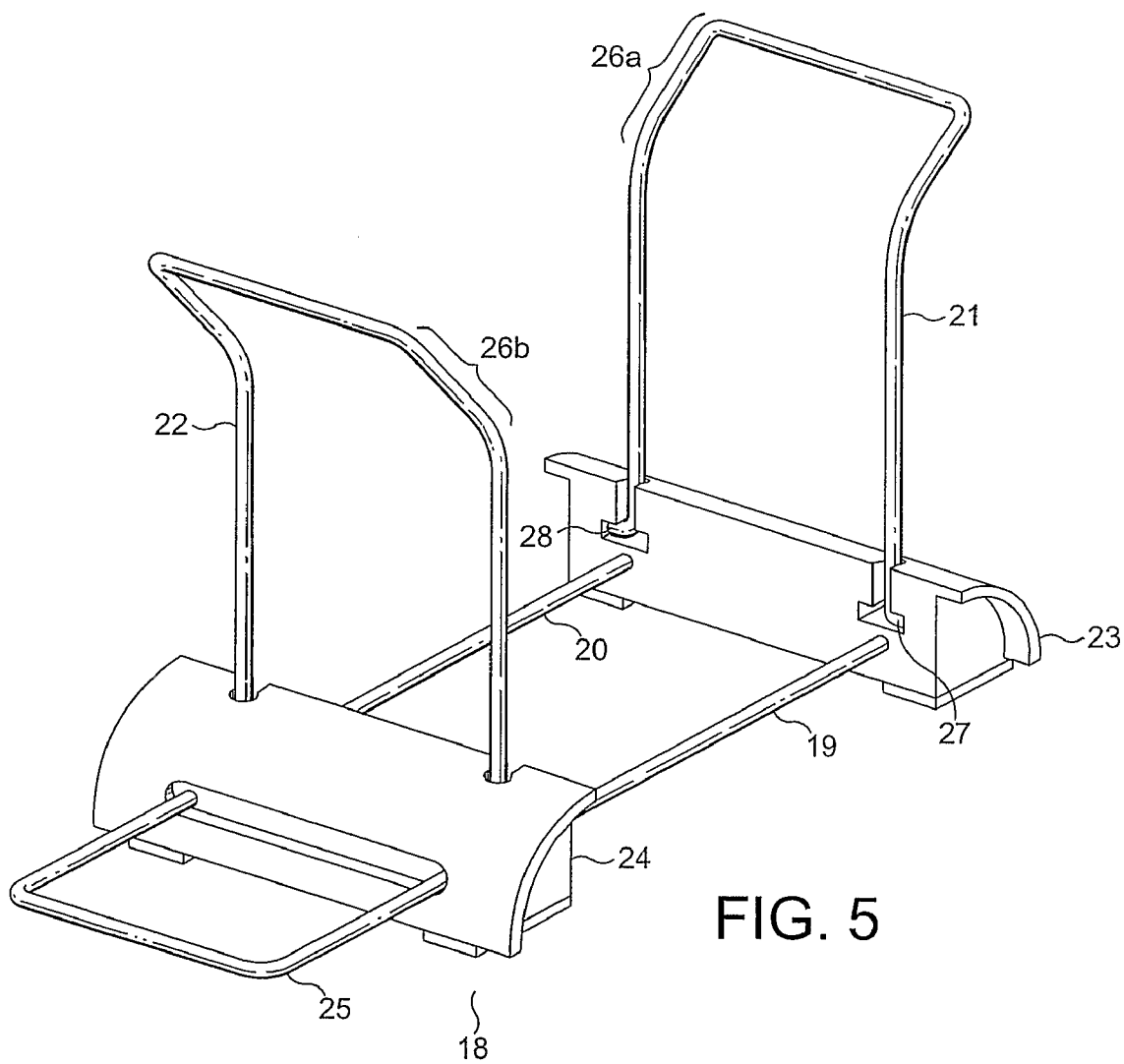

FIG. 5

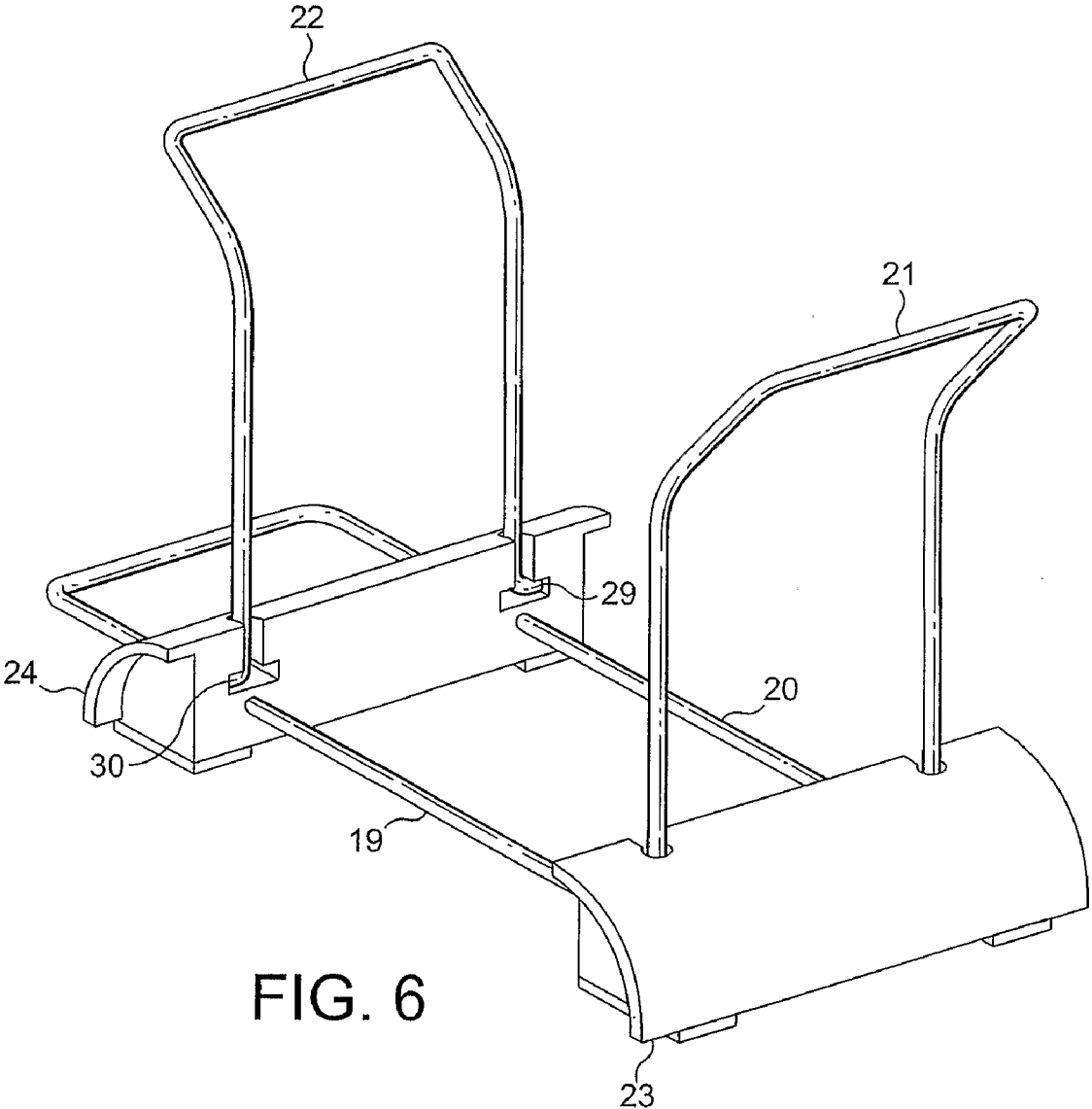

FIG. 6

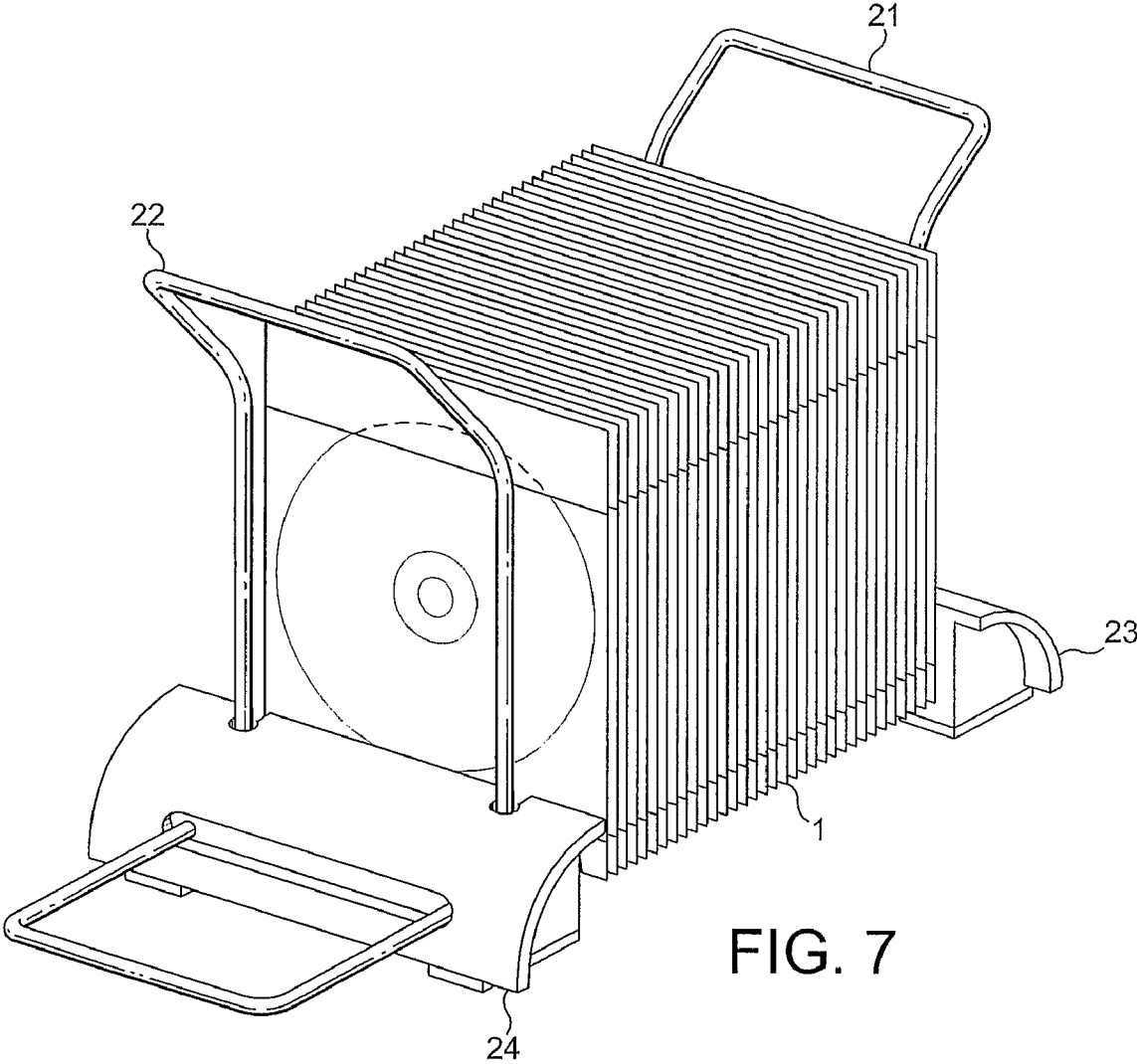

FIG. 7



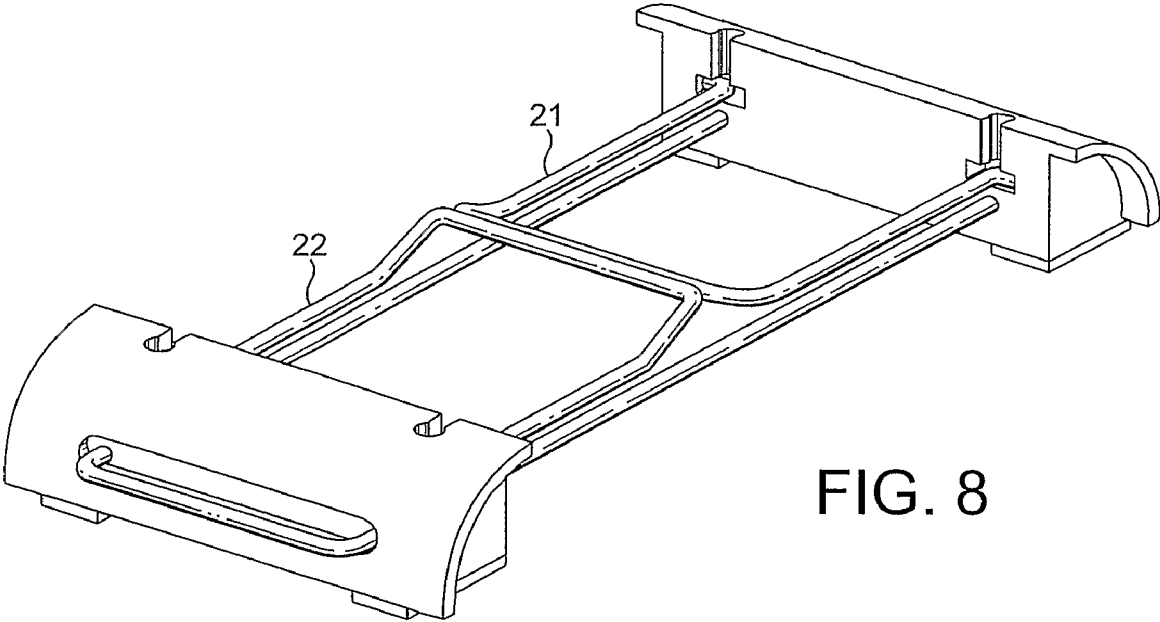
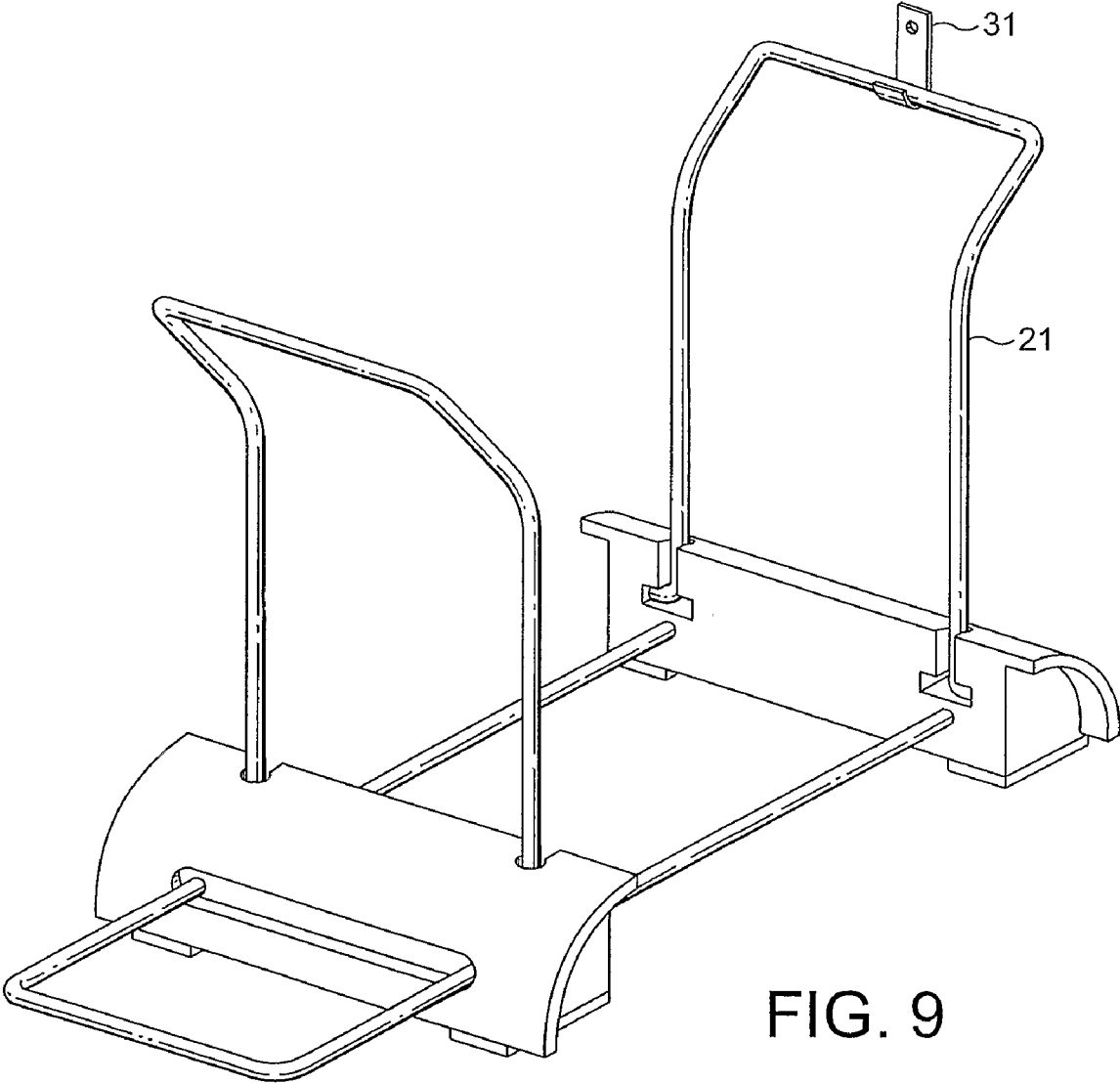

FIG. 8



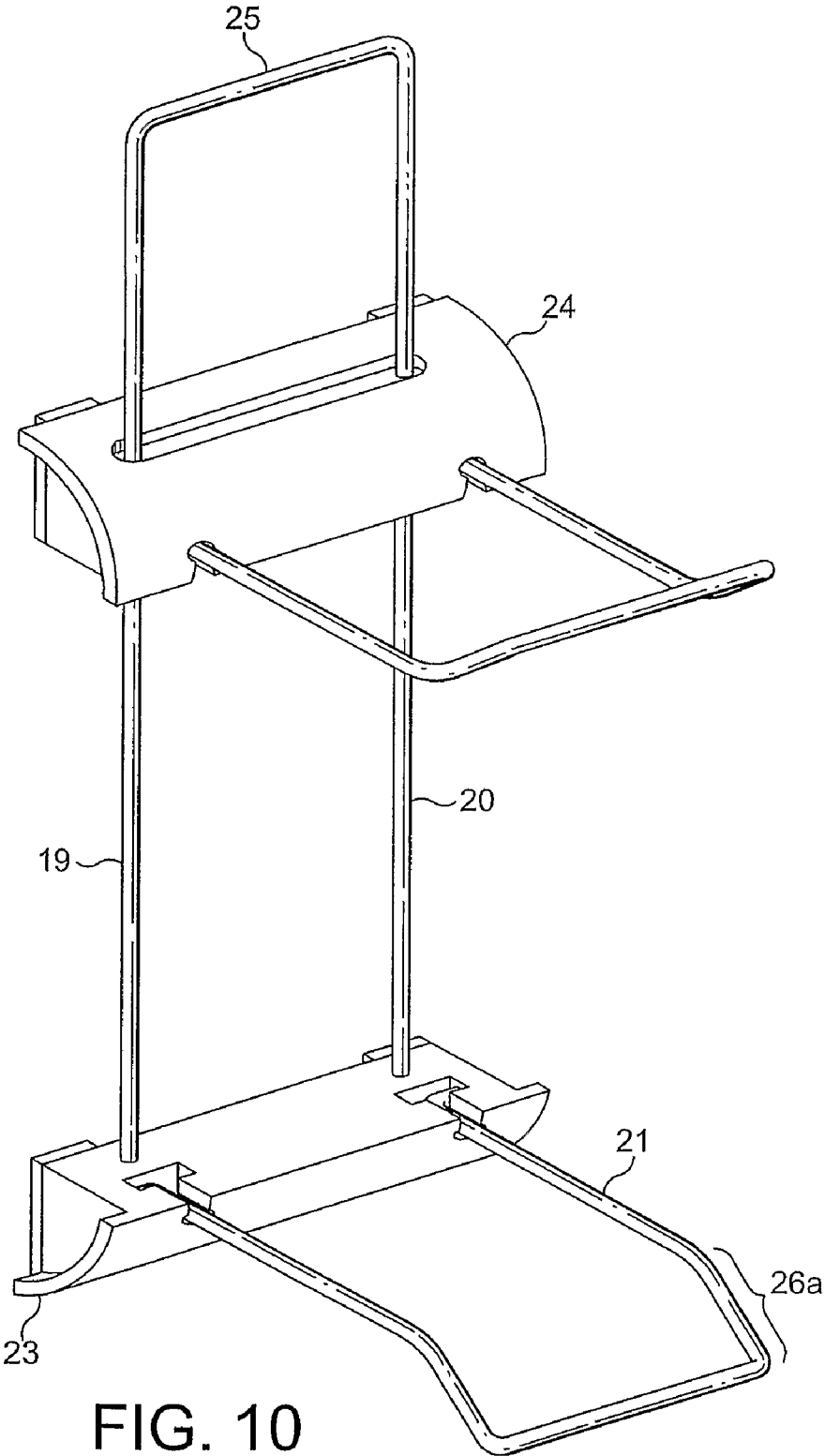

FIG. 10

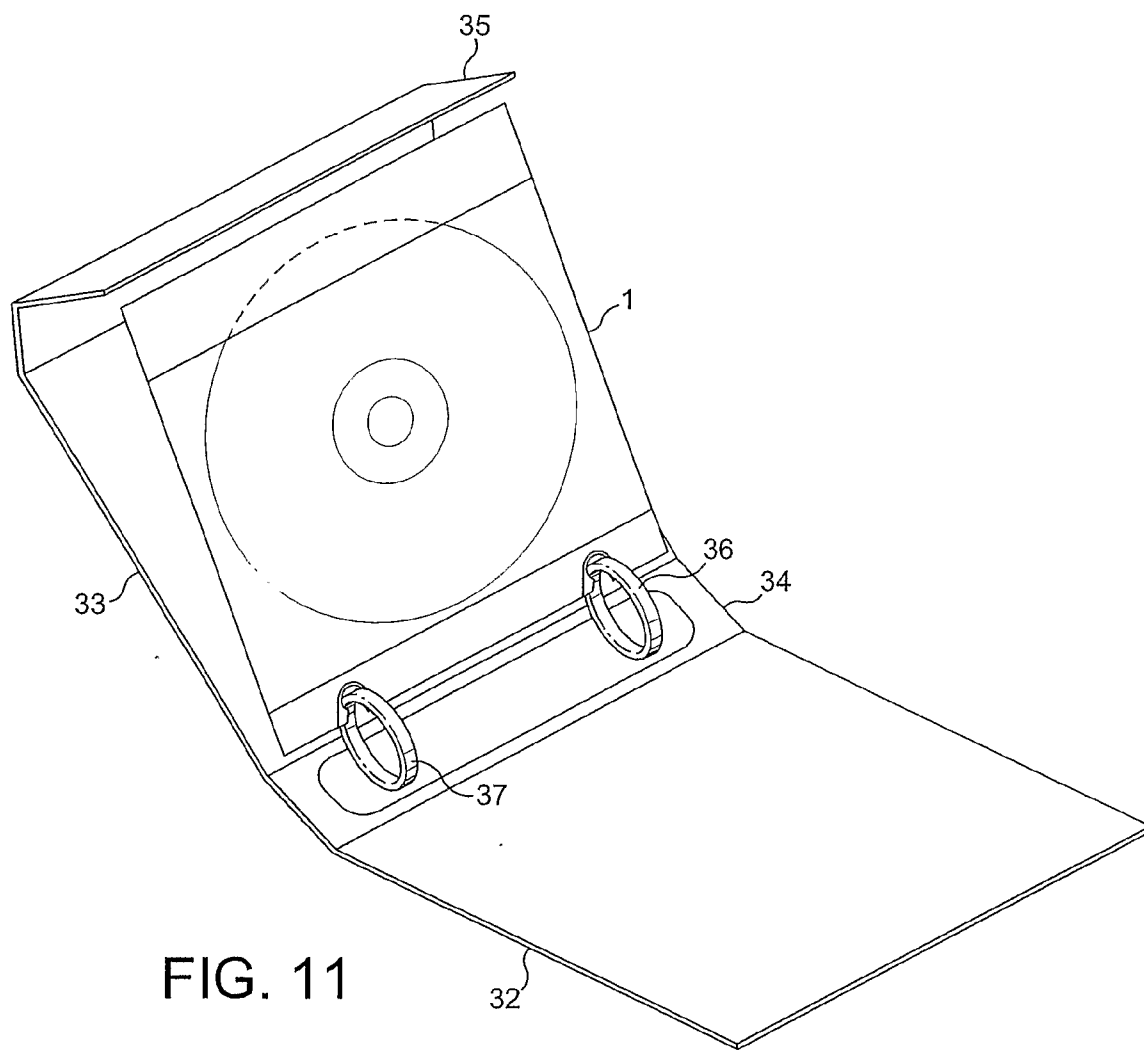

FIG. 11

## DISC STORAGE SYSTEM

[0001] This invention relates to a storage system principally but not exclusively for discs used to store data, such as compact discs, CD-ROM's, DVD's, so-called mini discs and so forth.

[0002] The content of the discs is immaterial, and could be music, video, multimedia, computer data, computer programs and so forth; indeed, the discs could be blank and to be used for the storage of such content. Likewise, the physical format of the discs is immaterial and whilst they will normally be circular discs they could be square, rectangular, hexagonal or any other regular or irregular shape. They could be discs that are intended to be rotated, as is currently the case with CD's and DVD's, or they could be of a format yet to be commercialised in which they are for example held stationary and scanned. The word "disc" is therefore to be construed broadly as covering a range of products which are not necessarily circular and which are not necessarily used in the same manner as current CD's or DVD's. In general, they will be planar objects and relatively thin, for example no greater than 5 mm in thickness and preferably nearer 1 mm. Typically, the maximum dimension, i.e. diameter in the case of a circular disc, will be less than 150 mm, and for a conventional CD or DVD may be in the region of about 100 to 120 mm. However, the dimensions of the disc are in general immaterial although it should be suitable for storage in a pouch as described below. The material of the disc is also irrelevant, although typically the disc will be lightweight and may be constructed of a plastics material. Although the physical properties of the disc are not relevant to the invention, the disc will generally be rigid although some degree of flexibility will often be present.

[0003] Although the invention is particularly applicable to a storage system for discs, it will be appreciated that the invention is equally suitable for storing other materials such as paper, books, newspapers or the like.

[0004] DVD's and CD's are in widespread use for the storage of music, video, computer data, computer programs and so forth. They may be supplied pre-recorded or blank for a user to record using suitable apparatus such as a computer read/write CD or DVD drive, or a DVD recorder specifically intended to record television programmes. A typical user may have hundreds of discs for various purposes and this gives rise to storage problems. Typically, consumers are provided with discs in rigid plastic cases. These are considerably thicker than the discs that they contain, and this adds to the storage problems. There have been many proposals for the storage of discs, ranging from complex rack or drawer systems to wallets for containing a selection of discs to be carried around, but these have various drawbacks. For example, typically if a user wants to carry a selection of discs around it will be necessary to remove the case from a rack or drawer system, take the disc out of the case, replace the empty case in the rack or drawer, and then place the disc inside a pouch in a wallet.

[0005] According to a first aspect of the invention, there is provided a storage system comprising a storage rack and a plurality of storage pouches removably engaged with the rack, wherein the storage rack comprises two parallel, laterally spaced elongate elements and each storage pouch is provided with a pair of engaging means arranged to engage with the respective elongate elements, each engaging means being resilient and having an open portion so that it can be pushed laterally on to its respective elongate element and will

resist unintentional disengagement from the elongate element, and wherein the engagement means permit sliding of the pouches with respect to the elongate elements.

[0006] According to a second aspect of an invention there is provided a storage system comprising a storage rack and at least one storage pouch, wherein the storage rack comprises two parallel elongate elements and the storage pouch comprises two apertures arranged to engage with said two parallel elongate elements. Preferably the engagement is in the form of a snap coupling allowing removal and attachment of the pouch. Preferably the engagement permits sliding of the pouch with respect to the elongate element.

[0007] In an alternative arrangement, there could be a single engaging means or aperture permitting attachment and removal of the pouch, with additional support means for the pouch. For example, there could be three, laterally spaced parallel elongate elements. Two may provide a supporting function only, and the third provide an attachment means.

[0008] According to another aspect of the invention there is provided a storage system comprising a storage rack and a plurality of storage pouches supported by and removably engaged with the rack, wherein the storage rack comprises an elongate element and each storage pouch is provided with engaging means arranged to engage with the elongate element, the engaging means being resilient and having an open portion so that it can be pushed laterally on to the elongate element and will resist unintentional disengagement from the elongate element, and wherein the engagement means permit sliding of the pouches with respect to the rack.

[0009] Another aspect of the present invention provides a storage pouch, preferably of flexible material, for a disc or other item which is versatile and can be removably used in a semi-permanent storage installation such as a rack, or in a portable product such as a storage wallet. According to this aspect of the invention there is provided a storage pouch having an opening adjacent one edge to permit insertion of a disc into, and removal of a disc from the pouch, and there being provided adjacent another edge of the pouch an aperture through the pouch, the aperture having a relatively wide portion for receiving an elongate storage element and a relatively narrow portion communicating with said other edge, so that by distortion of resilient material adjacent the relatively narrow portion the pouch can be located on and removed from the elongate storage element.

[0010] Typically, the relatively wide portion of the aperture will be circular so as to receive a circular storage rod, for example. However, other cross sections are possible and for example a square cross section aperture could be used with a matching elongate element or indeed with a circular cross section member. The relatively narrow portion may be in the form of a simple slit or slot extending from the wide portion to the edge. Alternatively, the relatively narrow portion may taper outwardly towards the edge of the pouch, to facilitate placing of the pouch on the storage element. In such an arrangement, the aperture will have the appearance of a key-hole.

[0011] Generally two apertures will be provided, one adjacent each end of said other edge. The pouch will then be suitable for use with a storage unit comprising two parallel elongate elements. The members need not extend in straight lines and can be curved for functional or aesthetic reasons. Generally, for a rack there will be two parallel straight members. For a wallet, there will generally be two parallel members, each bent into a loop.

**[0012]** A rack may be made of a single piece of metal wire or rod bent so as to provide two parallel elongate elements as well as an end stop and two feet at either end. In such an arrangement, the rack may also be stood on its end, with the two feet and an end of the end stop providing a three point support. Other forms of rack are possible as discussed below and may be made from wood, metal or plastics as desired, with the elongate elements likewise made from a chosen material such as metal, wood or plastic rods.

**[0013]** The pouch may be constructed from a suitable sheet material such as plastics (e.g. polypropylene or acrylic), and may be transparent, translucent, coloured or opaque as desired. The pouch may also be provided with internal surface (s) lined with a softer material so as to prevent scratching or other damage to the pouch contents.

**[0014]** Typically, the main part of the pouch may be generally square for simplicity of construction, having one edge open and the three other edges closed by bonding, welding or the like. The apertures for receiving the elongate elements may be adjacent the edge opposite the open edge.

**[0015]** One edge adjacent the opening of the pouch may be distorted outwardly, for example by providing a slight crease, to facilitate removal and insertion of a disc.

**[0016]** The pouch may be provided with a first extension adjacent the open edge, to act as or be able to receive a label. For example, the extension may be doubled back on itself and bonded, so as to provide a sleeve, open at one or each end, to receive a label. One of the faces of the sleeve may be provided with one or more cut-outs, such as an oval, so that a user can use a finger or thumb to help insert or remove a label.

**[0017]** The first extension may be arranged to form a flap (for example by being folded back on itself a second time) so that its lower edge extends beyond the top of the contents of the pouch e.g. a CD, thereby preventing the contents from falling out of the pouch. The pouch material is preferably suitably flexible to allow the flap to 'flip' over the top of a disc extending from the open edge thereby securing the disc in the pouch and similarly flipped behind the disc to allow the disc to be removed from the pouch.

**[0018]** Preferably, the pouch is provided with a second extension adjacent the edge opposite the open edge to act as, or forming a passage arranged to receive, a semi-rigid element. The semi-rigid element may be formed of the same or similar material to the pouch, which typically may be of flexible plastics material, but is selected to be more rigid than the pouch. The apertures and relatively narrow sections are preferably formed in the semi-rigid element thereby providing a rigid connection with the elongate storage element.

**[0019]** A pouch containing a disc is considerably thinner and lighter than a conventional plastic case containing a disc. For a given storage space, many more discs can be accommodated than with known systems. It is easy to flick through the pouches to identify a desired disc, and then to remove the pouch and disc from the elongate elements of a rack or wallet. The disc can then be used, carried around, mailed and so forth as desired. After use, the pouch containing the disc can be replaced on the elongate elements. There is the possibility of taking a pouch and disc from a long term storage rack and placing it in a wallet to be carried around, the wallet having a pair of parallel hoops which are received in the pouch apertures.

**[0020]** Dividers and if desired sub-dividers may be provided. These may be more rigid than the pouches if desired, although that is not necessary. The dividers or sub-dividers

preferably have labels which extend above the top of the pouches—including any pouch labels. Main dividers may for example have labels extending their full width, whereas sub-dividers may have labels extending only part way across. Sub-dividers may have their labels at staggered positions across, for ease of indexing.

**[0021]** Additionally, alternatively or even incorporated with the function of a divider, there may be provided one or more separators which can be used to keep a selection of pouches in a preferred position on a rack. Such a separator could be movable readily in one direction along the elongate elements but resist movement in the other. Pouches could then be pushed together at an appropriate point on the rack. The separators may have apertures to receive the elongate elements and sprung portions which engage the elongate elements to resist movement in one direction.

**[0022]** The pouch and/or dividers may be provided with cut-out portions extending through the front and rear portions of the pouch or divider to act as stencils or templates for a user. The size and shape of the cut-outs is preferably selected to correspond to the size of the label which can fit into the passage define by the first extension of the pouch and/or the labels of the sub-dividers.

**[0023]** The pouch may alternatively be arranged to be expandable so as to be able to contain articles of different thicknesses. In this arrangement the front and rear faces of the pouch may be connected together with a series of folds such that the closed edges of the pouch resemble a concertina. The front and rear face of the pouch can thereby move relative to one another such that the pouch can be expanded. In this arrangement the front and rear faces may each be provided with an extension adjacent the edge opposite the open edge and arranged to receive a semi-rigid element. The front and rear faces of the pouch can thereby be attached to elongate elements of a rack.

**[0024]** A stack of say 50, 100 or more blank discs can be supplied already within pouches, mounted on a suitable rack.

**[0025]** The size and configuration of the pouch apertures should be chosen, having regard to the form of the elongate elements on which the pouches are to be used, to enable the pouches to be placed on and removed from the elongate elements whilst resisting accidental removal. For example, they may be able to resist dropping out if a rack is turned upside down.

**[0026]** A rack may be so that the pouches rest on the elongate elements, are suspended from the elongate elements or project sideways from the elongate elements. The rack may have elongate elements following a curved path, for aesthetic or functional reasons, and may have continuous loops. The rack could be arranged to be positioned on a surface such as a desk or table, mounted on a wall, or for example could be in the form of a box or other case containing the two elongate elements. The rack in certain configurations may be positioned in an alternative manner, on one end. Portions of the rack may serve as a handle or handles to facilitate moving the rack around.

**[0027]** The rack may be provided with means such that it can be extended or made smaller, for example by lengthening or shortening the elongate elements. This could be done by using replacement elements or for example by having telescopic elements with a smaller diameter portion sliding inside a larger diameter portion. Thus the pouches can be easily accessed by expanding the rack and neatly tidied away by compressing the rack. An extendable rack could be useful for

packaging purposes, a consumer purchasing the rack in its smallest configuration and then expanding it as desired for use.

**[0028]** A wallet for containing a smaller number of pouches than a rack may resemble a loose leaf binder, but with continuous rings rather than rings which are opened to add or remove papers.

**[0029]** Another aspect of the invention relates to a complete system comprising a plurality of pouches as described above, in combination with a storage device comprising two parallel, elongate elements whose lateral spacing matches the lateral spacing of two apertures provided on each pouch. In one embodiment of this aspect of the invention, the storage device is in the form of a rack and the elongate elements are substantially straight. In another embodiment of this aspect of the invention, the storage device is in the form of a wallet and the elongate elements are in the form of hoops within the wallet.

**[0030]** Viewed from another aspect, the invention provides a rack for holding a plurality of pouches as described above, said rack comprising a pair of parallel, elongate elements arranged to pass through apertures of said pouches, said elongate elements extending between a first and second connecting member so that the rack can rest on a surface with the elongate elements extending parallel to the surface, and wherein end stops are connected to said first and second connecting members and extend in planes generally perpendicular to the elongate elements.

**[0031]** Preferably, at least one end stop is provided with a portion which extends outwardly from the plane of that end stop, and the respective connecting member is provided with a portion which projects outwardly from the plane of the end stop, so that the rack can rest on a surface in an alternative configuration with the end stop adjacent the surface and the elongate elements extending perpendicular to the surface, the rack being supported by the said outwardly extending portions of said end stop and connecting member.

**[0032]** Each end stop is preferably in the form of a U-loop extending in a direction generally perpendicular to the plane of the elongate elements with the ends of the U-loop terminating at a respective connecting member.

**[0033]** The end stops may be fixed to the connecting member or may be removable such that the rack can be folded flat. Preferably, the end stops are rotatably mounted about the connecting members such that the end stops can rotate between a position generally perpendicular to the plane of the elongate elements and a position generally in the plane of the elongate elements. Thus, the rack can be folded flat for packaging, storage or transport.

**[0034]** The elongate elements may be in the form of two parallel rods or bars fixed to, and terminating at, each connecting member. Preferably, the elongate elements are in the form of a U-loop having ends terminating at one connecting member and arranged such that the two parallel elongate members extend through the second connecting member. The U-portion of the U-loop is thereby disposed on the outside of the second connecting member. The second connecting member is preferably arranged to move relative to the first connecting member along the parallel elongate elements.

**[0035]** The second connecting member may be provided with a smooth lower surface or a wheel, roller or the like, so as to allow the second connecting member to move freely relative to the first connecting member on a surface. The first connecting member may be provided with an adhering lower surface (such as rubber for example) so as to resist movement

of the first connecting member when the second connecting member is moved relative thereto.

**[0036]** The connecting member(s) may be provided with recesses on a bottom surface such that the rack can be mounted on a vertical surface using a hook for example.

**[0037]** Viewed from another aspect, the invention provides a storage rack comprising a pair of parallel, laterally spaced elongate linear elements which extend between first and a second connecting members so that the rack can rest on a surface with the elongate elements extending parallel to the surface, wherein end stops are connected to said first and second connecting members and extend in planes generally perpendicular to said elongate elements, and wherein at least one end stop is provided with a portion which extends outwardly from the plane of that end stop, and the respective connecting member is provided with a portion which projects outwardly to a corresponding position, so that the rack can rest on a surface in an alternative configuration with the end stop adjacent the surface and the elongate elements extending perpendicular to the surface, the rack being supported by the said outwardly extending portions of said end stop and connecting member.

**[0038]** Viewed from another aspect, the invention provides a storage rack comprising a pair of parallel, laterally spaced elongate linear elements which extend between first and a second connecting members so that the rack can rest on a surface with the elongate elements extending parallel to the surface, wherein end stops are connected to said first and second connecting members and extend in planes generally perpendicular to said elongate elements, and wherein said second connecting member can move relative to said first connecting member along the elongate elements.

**[0039]** Viewed from another aspect, the invention provides a package comprising a plurality of discs, each within a pouch as described above, the pouches being mounted on the elongate elements of a rack of a storage system as described above. This provides a convenient and functional alternative to conventional methods of packaging bulk numbers of discs, for example.

**[0040]** Viewed from another aspect the invention provides a method of storing a plurality of discs, comprising the steps of placing each disc in a pouch as described above, and mounting each pouch on the elongate elements of a rack of a storage system as described above.

**[0041]** Another aspect of the invention provides a storage rack comprising a pair of substantially straight elongate elements disposed between a first and second support member, said first and second support members arranged such that in use the substantially straight elongate elements extend parallel to a surface; and a pair of inverted U-shaped end stops each connected to an upper surface of one of said first and second support members and extending in a plane generally perpendicular to the plane of the elongate elements; and wherein a portion of at least one of said inverted U-shaped end stops projects outwardly from the plane of that end stop.

**[0042]** It will be appreciated that each of the features described herein may be conveniently used in combination with each of the arrangements or embodiments described.

**[0043]** Some embodiments of the invention will now be described, by way of example only, and with reference to the accompanying drawings, in which:

**[0044]** FIG. 1 is a front view of a pouch in accordance with the invention containing a CD;

[0045] FIG. 2 is a front view of the pouch of FIG. 1 wherein the CD is secured within the pouch;

[0046] FIG. 3 is a front view of a pouch in accordance with the invention showing a label partially inserted;

[0047] FIG. 4 shows a pouch extension with a semi-rigid element;

[0048] FIG. 5 is a first perspective view of a rack in accordance with the invention, for use with a number of the pouches;

[0049] FIG. 6 is a second perspective view of a rack in accordance with the invention;

[0050] FIG. 7 shows a perspective view of a rack containing a number of the pouches shown in FIG. 1;

[0051] FIG. 8 shows a perspective view of a rack with the end stops folded flat;

[0052] FIG. 9 shows a rack arranged for mounted on a vertical surface;

[0053] FIG. 10 shows a rack in an alternative orientation;

[0054] FIG. 11 is a perspective view of a wallet containing a pouch in accordance with the invention;

[0055] Referring now to FIG. 1, there is shown a plastics pouch 1 of transparent plastics material, containing a compact disc 2 which has been inserted, and can be removed, through an opening 3 along one edge. The sheet of plastic material has a front face 4 and a rear face 5, and the other edges are bonded together or constituted by a fold in the material.

[0056] At the upper edge, the rear face 5 is provided with a first extension 6 which is doubled over once to provide a passage for receiving a label 7 which can describe the contents of the disc. The extension is sufficiently long that it can be doubled over a second time so that its lower surface 8 extends below the upper level of the CD 2 when the CD has been inserted into the pouch, with the extension 6 behind the CD 2. The extension is folded and bonded on an outer edge such that the width of the passage, and thereby the width of the label which can be accommodated in the passage, is unaffected.

[0057] FIG. 1 shows the extension when a CD 2 is inserted into pouch 1. FIG. 2 shows the extension 6 having been folded over the top of the CD 2 (shown as a dotted line). The lower edge of the extension 6 can be seen to be below the upper level of the CD 2. The arrangement of the extension 6 thereby contains the CD in the pouch and prevents the CD (or contents of the pouch) from falling out of the top of the pouch. To secure a CD in the pouch, the user simply slides the CD into the pouch and then flips the extension over the front of the CD. The pouch and extension materials are sufficiently flexible that the extension can be flipped over the front of the CD to retain the CD and then flipped to the back of the CD so that the CD can be removed.

[0058] FIG. 3 shows the label 9 partially inserted into the passage defined by the first extension 6. The rear side of the passage is provided with two oval openings 10, 11 (shown in FIG. 2), so that a thumb or finger can manipulate the label during insertion or removal.

[0059] Referring back to FIG. 1, the pouch 1 is provided with second extension 12 adjacent the edge opposite the opening 3 which is arranged to provide a passage for receiving a strip 13. Strip 13 is more rigid than the pouch and acts to support the pouch on, for example, the elongate straight elements 19, 20 shown in FIG. 5. The strip 13 is made of thicker material than pouch 1 so as to provide increased rigidity, for example polypropylene having a thickness of approximately 3 mm. Strip 13 provides a rigid strip which acts to grip the

straight elongate elements shown in FIG. 5. The strip is bonded into the passage by welding.

[0060] The strip 13 contains two 'keyhole' shaped apertures 14, 15 each having a circular portion communicating with the edge via a narrower, but outwardly tapering, portion. These keyhole portions act to engage with the elongate elements shown in FIG. 5.

[0061] FIG. 4 shows a larger illustration of the second extension 12 and the keyhole portions 14, 15. As shown in FIGS. 1 and 4 the second extension is provided with generally triangular openings 16, 17 corresponding to the positions of the keyhole portions 14, 15.

[0062] FIG. 5 shows a storage rack 18 for use with a number of the pouches described above with reference to FIGS. 1 to 4. The rack comprises two parallel, elongate straight elements 19 and 20 in the form of circular cross section rods. The two parallel elongate elements are disposed between end stops 21 and 22, which are generally mirror images in terms of construction.

[0063] The two parallel, straight elongate elements 19, 20 extend between a first and second connecting member 23, 24.

[0064] The straight elongate elements 19, 20 are formed of a circular cross section rod or bar bent into a U-shape. The circular cross-section U-shape is arranged such that the two elongate elements 19, 20 pass through the second connecting member 24 and terminate in the first connecting member 23. The U-section thereby projects from the second connecting member 24 as shown by reference 25 in FIG. 5. The second connecting member is provided with holes corresponding in size to the elongate members such that the second connecting member can slide relative to the first connecting member along the straight elongate elements 19, 20. The distance between the connecting members 23, 24 can thereby be altered to increase or decrease the space for pouches on the rack. This also conveniently allows particular pouches to be located and removed or connected to the rack.

[0065] In order to prevent the entire rack moving when the second connecting member is moved relative to the first, the first connecting member is provided with rubber surface or coating so as to grip the surface on which the rack is placed. The under surface of the second connecting member may be substantially smooth and/or provided with a wheel, ball, roller or the like so as to allow free movement relative to the first connecting member.

[0066] FIG. 6 shows the rack from an alternative angle.

[0067] FIG. 7 shows the rack containing a plurality of the pouches 1 as shown in FIG. 1 to 4. The pouches are arranged on the elongate members 19, 20 shown in FIGS. 5 and 6 and have been attached to the elongate members by pushing the pouch onto the rack thereby forcing each elongate member through the respective outwardly tapering portions of the keyhole apertures 14, 15 shown in FIG. 1. The pouches can be readily removed and replaced, as desired. FIG. 7 also illustrates how the end stops 21, 22 can conveniently be used to carry the rack and pouches.

[0068] FIGS. 5, 6 and 7 show end stops 21, 22 extending upwardly from the first and second connecting members 23, 24 respectively. As shown in FIG. 7 the end stops 21, 22 act to support the pouches when arranged on the elongate elements 19, 20.

[0069] The end stops 21, 22 are each formed of a continuous length of metal rod which has been bent into a U-shape as



shown in FIG. 5. The upper end of the end stops 21, 22 are inclined away from the centre of the rack as shown by references 26a and 26b in FIG. 5.

[0070] The lower ends of the end stops 21, 22 are connected to the connecting members in slots as illustrated by references 27 and 28 in FIG. 5 and by references 29 and 30 in FIG. 6. The slots are arranged such that the end stops can rotate between a generally vertical position, as shown in FIGS. 5 and 6 and a generally horizontal position as shown in FIG. 8. This allows the rack to be folded flat when not in use or for packaging or transport. The slots 27, 28, 29, 30 are preferably formed such that the end stops remained locked in a vertical or horizontal position until moved by the user.

[0071] FIG. 9 shows a configuration where the rack is arranged on a wall as opposed to a flat surface. As illustrated, the end stop 21 can be conveniently located on a hook 31 such that the rack can be suspended against a wall or the like.

[0072] FIG. 10 shows the rack in an alternative orientation wherein the rack is arranged to hold pouches in a horizontal plane. As shown, the first connecting member 23 in combination with the end stop 21 act to support the rack on its end. The angled portion 26a of the end stop 21 is such that the rack rests on the end of the end stop 21 and the bottom of the first connecting member 23. The rack is thereby flat and stable when placed on its end. In this arrangement the second connecting member 24 moves vertically relative to the first connecting member 23 along the elongate members 19, 20. In this arrangement the portion 25 of the elongate elements can be conveniently used as a carrying handle.

[0073] FIG. 11 shows a wallet for holding a selection of pouches as shown in FIGS. 1 to 4. The wallet has main portions 32 and 33 joined by a spine portion 34. The end of portion 33 is provided with a flap 35. On the spine portion 34 are provided two parallel metal continuous loops 36 and 37, to receive pouches 1 in the same manner as the straight rods in the preceding embodiments. The pouch can be readily mounted by pushing it onto the loops. It will then stay in position until deliberately pulled off.

[0074] There is thus provided a novel and versatile disc storage system, incorporating a novel pouch with an easy-entry opening and easy to use labelling arrangement which prevent the contents of the pouch from accidentally falling out. The system also provides a novel rack which can be used in alternative orientations, whether for keeping a collection of discs or supplying blank disks in bulk, and also a novel wallet.

1. A storage system comprising a storage rack and a plurality of storage pouches removably engaged with the rack, wherein the storage rack comprises two parallel, laterally spaced elongate elements and each storage pouch is provided with a pair of engaging means arranged to engage with the respective elongate elements, each engaging means being resilient and having an open portion so that it can be pushed laterally on to its respective elongate element and will resist unintentional disengagement from the elongate element, and wherein the engagement means permit sliding of the pouches with respect to the elongate elements.

2. A storage system as claimed in claim 1, wherein said pouch has an opening adjacent one edge to permit insertion of an item into, and removal of an item from the pouch, and wherein each engaging means is provided adjacent an other edge of the pouch and comprises an aperture through the pouch, the aperture having a relatively wide portion for receiving one of the elongate storage elements and a relatively narrow portion communicating with said other edge, so that by distortion

of resilient material adjacent the relatively narrow portion the pouch can be located on and removed from the elongate storage element.

3. A storage system as claimed in claim 2, wherein said other edge is opposite said one edge.

4. A storage system as claimed in claim 2, wherein the pouch is of flexible material and further comprising an extension adjacent said other edge, the extension being provided with an element which is of resilient material which is stiffer than the remainder of the pouch, and wherein the apertures are formed in said element.

5. A storage system as claimed in claim 2, further comprising a flexible extension adjacent said one edge, the extension forming a flap movable between a first position in which the flap is disposed behind an object extending from said open edge of the pouch to allow an object to be inserted or removed from the pouch, and a second position in which the flap is disposed over a portion of an object extending from said open edge of said pouch to secure said object within the pouch.

6. A storage system as claimed in claim 5, wherein the flexible extension is further provided with a sleeve for receiving a label.

7. A storage system as claimed in claim 1, wherein the elongate elements are linear and two end stops are disposed at either end of the rack.

8. A storage system as claimed in claim 7, wherein the elongate elements extend between a first and a second connecting member so that the rack can rest on a surface with the elongate elements extending parallel to the surface, and wherein the end stops are connected to said first and second connecting members and extend in planes generally perpendicular to said elongate elements.

9. A storage system as claimed in claim 8, wherein at least one end stop is provided with a portion which extends outwardly from the plane of that end stop, and the respective connecting member is provided with a portion which projects outwardly to a corresponding position, so that the rack can rest on a surface in an alternative configuration with the end stop adjacent the surface and the elongate elements extending perpendicular to the surface, the rack being supported by the said outwardly extending portions of said end stop and connecting member.

10. A storage system as claimed in claim 8, wherein each end stop is in the form of a U-shaped loop having ends terminating at a respective connecting member.

11. A storage system as claimed in claim 8, wherein the end stops are rotatably mounted on said first and second connected members such that they can rotate from their position generally perpendicular to said elongate elements, to a second position generally parallel with said elongate elements.

12. A storage system as claimed in claim 8, wherein the end stops are removably connected to said connecting members.

13. A storage system as claimed in claim 8, wherein said second connecting member can move relative to said first connecting member along the elongate elements.

14. A storage system as claimed in claim 1, wherein the elongate elements are legs of a U-shaped member having its free ends connected to the first connecting member, the elongate elements extending in sliding fashion through the second connecting member.

15. A storage system as claimed in claim 13, wherein the second connecting member is provided with means to facilitate movement over a surface on which the rack rests.

**16.** A storage system as claimed claim 1, wherein the storage rack is in the form of a wallet and the elongate elements are in the form of hoops within the wallet.

**17.** A storage system as claimed in claim 1, wherein each pouch is adapted to contain a data disc.

**18.** A storage rack for use in a storage system as claimed in claim 1 comprising a pair of parallel, laterally spaced elongate linear elements which extend between first and a second connecting members so that the rack can rest on a surface with the elongate elements extending parallel to the surface, wherein end stops are connected to said first and second connecting members and extend in planes generally perpendicular to said elongate elements, and wherein at least one end stop is provided with a portion which extends outwardly from the plane of that end stop, and the respective connecting member is provided with a portion which projects outwardly to a corresponding position, so that the rack can rest on a surface in an alternative configuration with the end stop adjacent the surface and the elongate elements extending perpendicular to the surface, the rack being supported by the said outwardly extending portions of said end stop and connecting member.

**19.** A storage rack for use in a storage system as claimed in claim 1, comprising a pair of parallel, laterally spaced elongate linear elements which extend between first and a second connecting members so that the rack can rest on a surface with the elongate elements extending parallel to the surface, wherein end stops are connected to said first and second connecting members and extend in planes generally perpendicular to said elongate elements, and wherein said second

connecting member can move relative to said first connecting member along the elongate elements.

**20.** A storage pouch for use in a storage system as claimed in claim 1, wherein said pouch has an opening adjacent one edge to permit insertion of an item into, and removal of an item from the pouch, and wherein a pair of engaging means are provided adjacent an other edge of the pouch, each engaging means comprising an aperture through the pouch, the aperture having a relatively wide portion for receiving an elongate element and a relatively narrow portion communicating with said other edge, so that by distortion of resilient material adjacent the relatively narrow portion the pouch can be located on and removed from the elongate storage elements of the rack of the storage system.

**21.** A storage system comprising a storage rack and a plurality of storage pouches supported by and removably engaged with the rack, wherein the storage rack comprises an elongate element and each storage pouch is provided with engaging means arranged to engage with the elongate element, the engaging means being resilient and having an open portion so that it can be pushed laterally on to the elongate element and will resist unintentional disengagement from the elongate element, and wherein the engagement means permit sliding of the pouches with respect to the rack.

**22.** A storage system as claimed in claim 17, including data discs stored in the pouches.

**23.** A package comprising a storage system as claimed in claim 22, with a blank data disc stored in each pouch.

\* \* \* \* \*