

Nov. 12, 1968

E. BUCHER ET AL

3,409,958

APPARATUS FOR STRETCHING AND SHRINKING YARNS

Filed Aug. 22, 1966

6 Sheets-Sheet 1

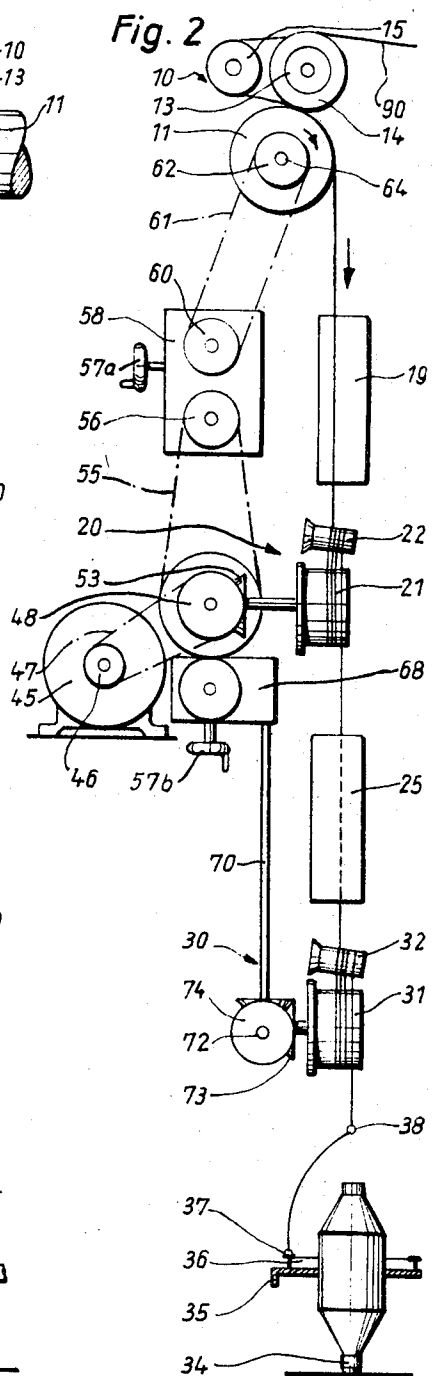
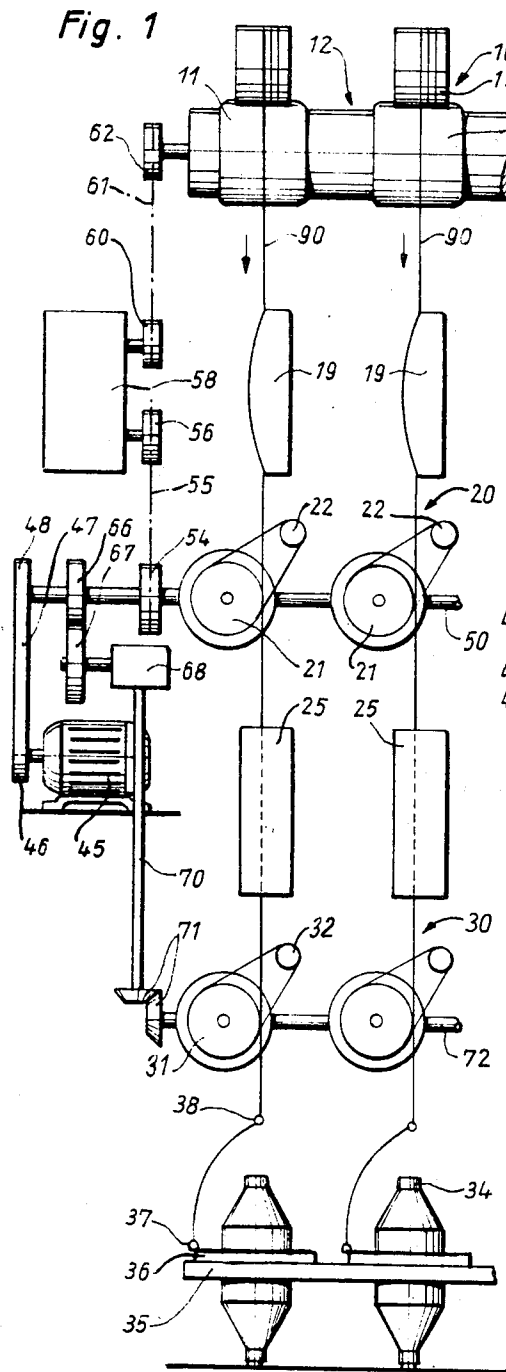

**Inventors**  
Erich Bucher  
Horst Haarriger  
Günter Mutschler  
by Michael S. Striker  
R.H.

Nov. 12, 1968

E. BUCHER ET AL

3,409,958

APPARATUS FOR STRETCHING AND SHRINKING YARNS

Filed Aug. 22, 1966

6 Sheets-Sheet 2

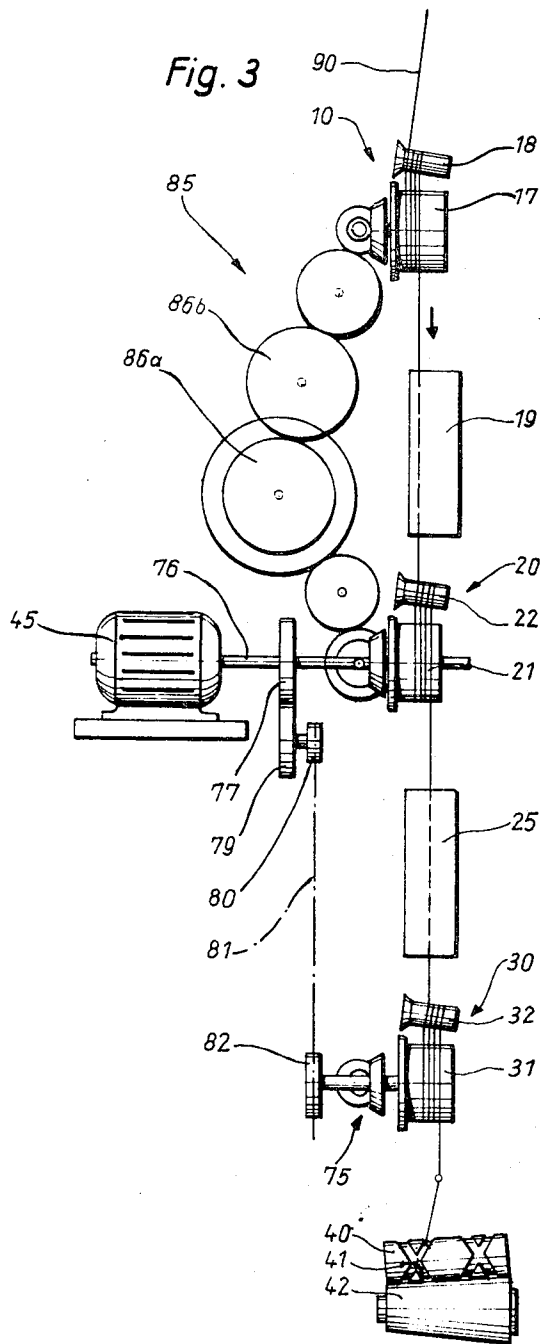

**Inventors**

Erich Bucher  
Horst Hanning  
Günther Pfeiffer  
by Michael S. Strider  
Attorney

Nov. 12, 1968

E. BUCHER ET AL

3,409,958

APPARATUS FOR STRETCHING AND SHRINKING YARNS

Filed Aug. 22, 1966

6 Sheets-Sheet 3

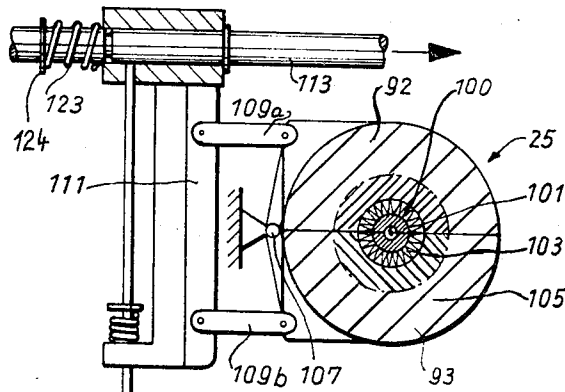

Fig. 4

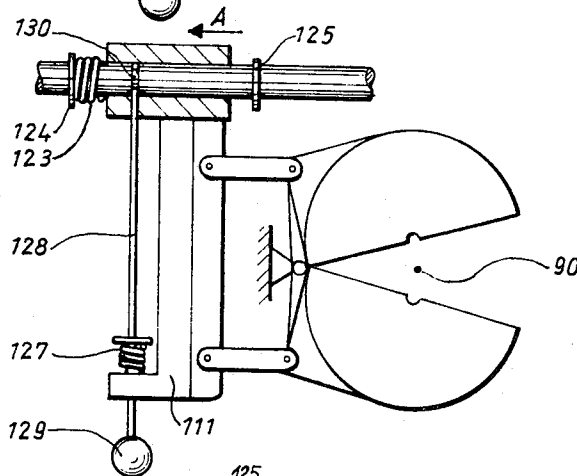

Fig. 5

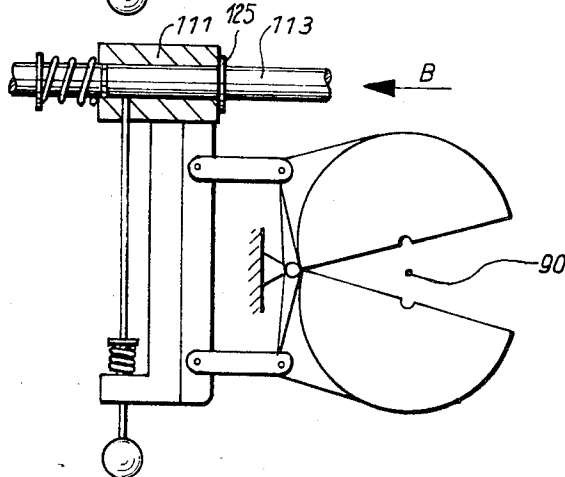

Fig. 6

Inventors

Erich Bucher  
Horst Hansen  
Günther Kötter  
By Richard S. Stone  
Attorney

Nov. 12, 1968

E. BUCHER ET AL

3,409,958

APPARATUS FOR STRETCHING AND SHRINKING YARNS

Filed Aug. 22, 1966

6 Sheets-Sheet 4

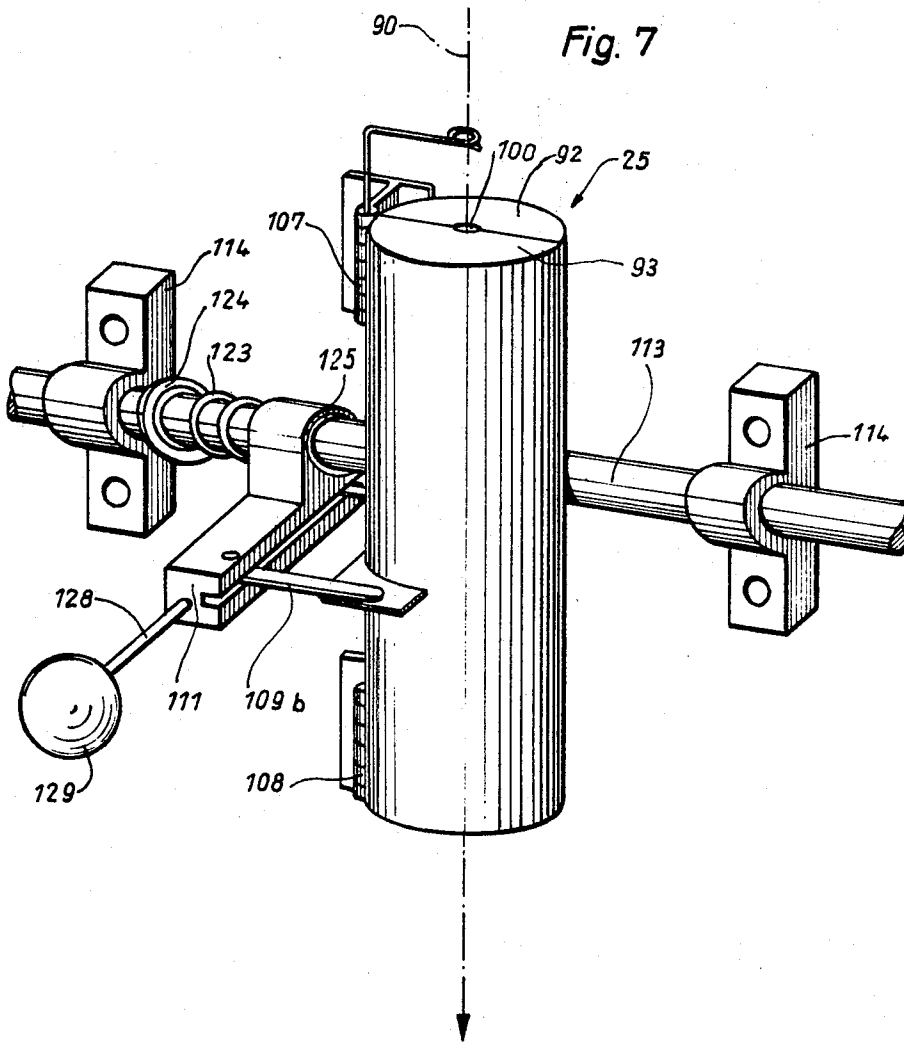

**Inventors**  
Erich Bucher  
Horst Haninger  
Günter Pfeiffer  
by Michael J. Straker  
Att.

Nov. 12, 1968

E. BUCHER ET AL

3,409,958

APPARATUS FOR STRETCHING AND SHRINKING YARNS

Filed Aug. 22, 1966

6 Sheets-Sheet 5

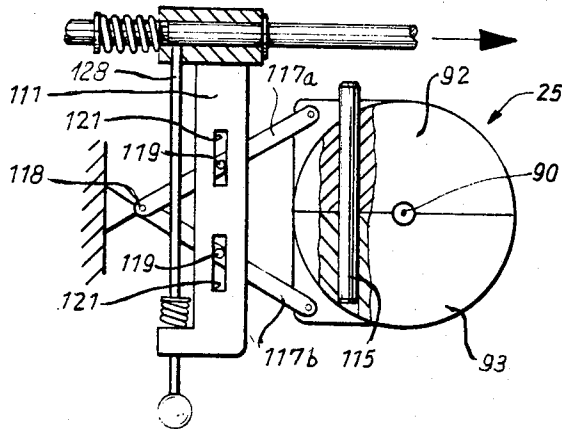

Fig. 8

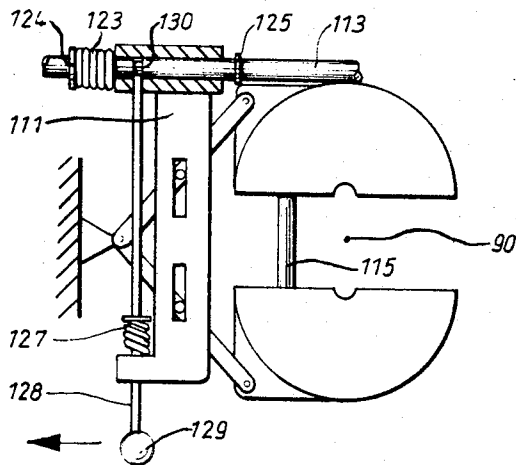

Fig. 9

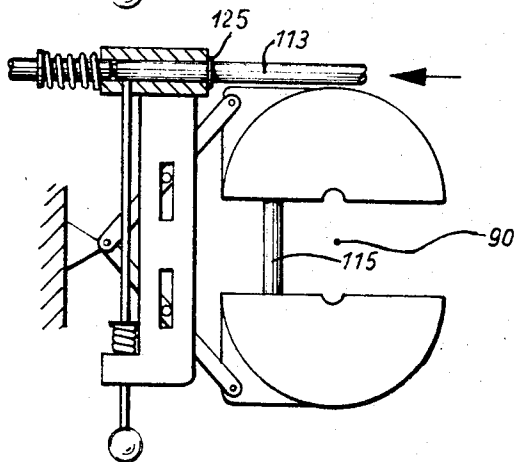

Fig. 10

**Inventors**

Erich Bucher  
Horst Haminger  
Oskar Mutschler  
1968 Michael S. Stricker  
N.Y.

Nov. 12, 1968

E. BUCHER ET AL

3,409,958

APPARATUS FOR STRETCHING AND SHRINKING YARNS

Filed Aug. 22, 1966

6 Sheets-Sheet 6

Fig. 11

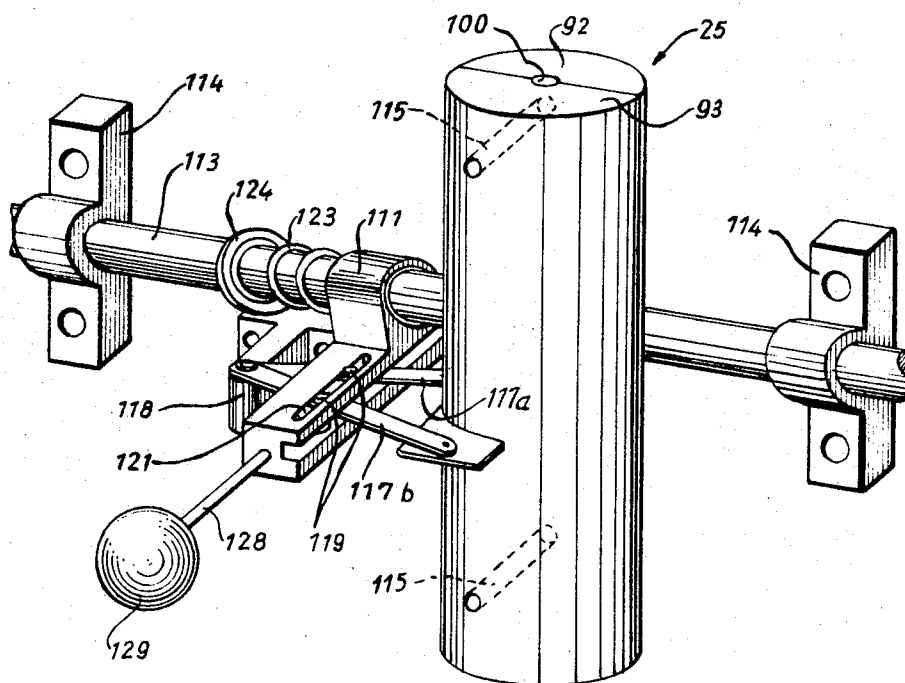

**Inventors**

Erich Bucher  
Horsel Hamner  
Günther Metzdorf

by Michael S. Strasser  
1968

1

2

3,409,958  
**APPARATUS FOR STRETCHING AND SHRINKING YARNS**

Erich Bucher, Goppingen, Horst Haninger, Ebersbach (Fils), and Gunter Mutschler, Aichelberg-Zell, Germany, assignors to Zinser-Textilmaschinen Gesellschaft mit beschränkter Haftung, Ebersbach (Fils), Germany

Filed Aug. 22, 1966, Ser. No. 574,074  
 Claims priority, application Germany, Aug. 26, 1965, Z 11,722  
 19 Claims. (Cl. 28—71.3)

**ABSTRACT OF THE DISCLOSURE**

A yarn is first stretched at a first speed and then guided at a second lower speed through a shrinking area where the yarn passes between a pair of heater segments forming a central channel for the yarn. At least one heater segment can be moved to a position opening the channel along the entire length thereof for insertion and removal of the yarn, and also for momentarily starting and stopping the heating of the yarn independently of the movement of the yarn.

The present invention relates to a method and apparatus for stretching and shrinking a yarn, filament, or like elongated flexible elements, and more particularly to a method and apparatus for stretching and shrinking a yarn consisting of synthetic polymers in a continuous operation.

According to the prior art, yarns or filaments made of synthetic high polymers are wound on spools directly after leaving the spinning nozzle and solidifying. The wound up yarn is then supplied to a draw twisting machine or to a stretching and winding machine on which the yarn is stretched to a multiple of its initial length to obtain the required tensile strength and stretch. In some cases, the stretched condition of the yarn is fixed by a heat treatment. Irrespective of whether the yarn stretch has been fixed by heating or not, the stretched yarn has a tendency to shrink in longitudinal direction, which is a substantial disadvantage. If a stretched yarn is wound on a spool in this condition, the windings of the inner layers shrink less than the windings of the outer layers so that the properties of successive sections of the yarn are different, which may cause color differences between the yarn of the inner and outer layers when the yarn is dyed.

In order to prevent the uneven shrinking of the stretched yarn, it is known to wind the yarn on a yielding core, and to store the yarn for a considerable time period in a heated chamber. The yarn shrinks to a final length while compressing the yielding core. However, this shrinking process is time-consuming and expensive.

It is one object of the invention to overcome the disadvantages of the prior art, and to shrink a stretched yarn to a final condition in a simple, continuous, and inexpensive operation.

Another object of the invention is to shrink a stretched yarn in such a manner that the quality of the yarn is not detrimentally affected.

Another object of the invention is to provide a method and apparatus for stretching and shrinking a yarn or filament consisting of a synthetic polymer in a continuous operation so that the treated yarn has no further tendency to shrink, and can be wound up.

In accordance with the preferred embodiment of the invention, a yarn or filament made of synthetic high polymers is stretched a predetermined amount in at least one stretching area, and directly thereafter shrunk a predetermined amount in a shrinking area in which heat is ap-

plied to the yarn. The yarn enters and leaves each of the successive stretching and shrinking areas at predetermined entry and exit speeds.

This method of the invention permits the stretching, and shrinking of the yarn to a final length in a continuous operation. The amount of stretching, and the amount of shrinking of the yarn can be exactly determined by suitably selecting the entry speed and exit speed of the yarn in each area, particularly in the shrinking area so that no shrinking of the yarn can take place after the treatment in accordance with the method of the invention.

The heat treatment of the yarn in the shrinking area is preferably carried out only in a part of the shrinking area by a heater maintaining a predetermined, preferably adjustable temperature which is higher than the room temperature.

It is particularly advantageous (preferably in the case of polyester yarns) for the shrinking of the yarn, to heat the yarn also in the stretching area. For this purpose, a part of the stretching area is maintained at a higher temperature.

In the apparatus of the invention, a shrinking area directly follows a stretching area, and transporting means which transport the yarn without slippage, transport the yarn into and out of each area. The transporting speeds are constant and preferably adjustable. Heating means are provided in the shrinking area, and preferably also in the stretching area for heating the yarn.

An embodiment of the apparatus of the invention comprises at least one first transporting means for transporting the yarn at a predetermined first speed into a stretching area; at least one second transporting means for transporting the yarn at a predetermined second speed higher than the first speed out of the stretching area and into a shrinking area adjacent the stretching area; heating means in the shrinking area for heating the yarn in the shrinking area; and at least one third transporting means spaced a predetermined distance from the second transporting means for transporting the heated yarn at a predetermined third speed lower than the second speed out of the shrinking area. The first, second and third speeds, and the distances between the first and second transporting means, and the second and third transporting means are selected so that the yarn is first stretched a predetermined amount in the stretching area, and then shrunk a predetermined amount in the shrinking area. The speed at which the shrunk yarn is transported out of the shrinking area is higher than the speed at which the yarn is transported into the stretching area so that the shrunk yarn is longer than the yarn supplied to the apparatus.

The yarn in the shrinking area is preferably heated by a heating device according to the present invention which cannot only be used for the stretching and shrinking method of the invention, but also for the heat treatment of moving yarns or other elongated flexible elements.

The novel features which are considered as characteristic for the invention are set forth in particular in the appended claims. The invention itself, however, both as to its construction and its method of operation, together with additional objects and advantages thereof, will be best understood from the following description of specific embodiments when read in connection with the accompanying drawings, in which:

FIG. 1 is a schematic front view illustrating an embodiment of the apparatus of the invention;

FIG. 2 is a schematic side view of the embodiment of FIG. 1;

FIG. 3 is a schematic side view illustrating a modified embodiment of the invention;

FIG. 4 is a horizontal sectional view illustrating a heat-

ing device and associated control means in a closed operative position;

FIGS. 5 and 6 are plan views, partially in section, illustrating the apparatus of FIG. 4 in two other operational positions;

FIG. 7 is a fragmentary perspective view illustrating the apparatus of FIG. 4.

FIG. 8 is a plan view, partially in section, illustrating a heating device and associated control means according to a modified embodiment in the closed operative position;

FIGS. 9 and 10 illustrate the apparatus of FIG. 8 in two other operational positions; and

FIG. 11 is a fragmentary perspective view illustrating the apparatus of FIG. 8.

Non-essential and conventional parts have been omitted in the drawing for the sake of clarity, and like elements are indicated by like reference numerals.

Referring now to the embodiment of FIGS. 1 and 2, the apparatus is arranged on a draw twisting machine, not shown, and includes a plurality of paths for yarn, only two paths being shown, each path including a stretching area (for example length 250-500 mm., preferably 300 or 400 mm.) located between the respective rollers 11 and 21, and a shrinking area (for example length 500-700 mm.) located between the respective rollers 21 and 31. A yarn or filament 90 (in general 15-210 denier) consisting of a synthetic polymer is transported along each path first through a stretching area in which it is stretched or drawn (in general 3.5-4.5 times) a predetermined amount, and then through a shrinking area in which it shrinks a predetermined amount (in general in the range of 5-15% of this stretched length). Each yarn 90 is then wound up as a package on a tube 34. Along each path, a first transporting means 10 transports the yarn 90 into the stretching area, a second transporting means 20 transports the respective yarn out of the stretching area and into the shrinking area, and a third transporting means 30 (for example transporting velocity 300-800 m./min., preferably 500 m./min.) transports the yarn out of the shrinking area and through a yarn guide 38 to the traveler 37 on a ring 36 located on a rail 35 of a ring twisting machine so that each shrunk yarn is wound up on a tube 34 as a package.

A heating device 19 (in the case of polyester yarn the heating temperature may be 5-15% lower than the heating temperature in the shrinking area) is provided in each stretching area, and a heating device 25 (heating temperature at yarn velocity 500 m./min. in general 180-200° C., at 300 m./min. in general 165-175° C., at 800 m./min. in general 240-260° C.) is provided in each shrinking area. In the embodiment of FIG. 1, the heating device 19 may be simply a heated plate over which the yarn slides, while the heating device 25 is preferably constructed as will be described with reference to FIGS. 4 to 11. However, it is also possible to use one of the heating devices illustrated in FIGS. 4 to 11 for heating the yarn in the stretching area.

Each first transportation means 10 includes a driven roller 11 and a cooperating roller 13 provided with an elastic cover sleeve 4. Roller 13, 14 is movably mounted in the usual manner and spring biased to resiliently engage the surface of the driven roller 11. All rollers 11 of which only two are shown, are portions of a shaft 12 which is driven by a chain wheel 62. Yarn 90 is wound in several loops about roller 13, 14 and about a cylindrical rotatable thread guide 15 which has a plurality of annular guide grooves.

The transporting means 20 and 30 each include a driven roller 21 and 31, respectively, cooperating with a smaller roller 22 and 32, respectively, the yarn being wound in several loops about rollers 21, 22 and 31, 32 to prevent slippage.

A drive motor 45 drives a main shaft 50 by means of pulleys 46, 48 and a belt 47. The transverse shafts of

rollers 21 carry bevel gears 53 meshing, respectively, with bevel gears, not shown, on main shaft 50 so that rollers 21 are driven at the rotary speed determined by the transmission ratio of the pulley and belt drive 46, 47, 48. The speed of rollers 21 must be higher than the speeds of rollers 11 and 31.

Main shaft 50 carries a gear 66 meshing with a gear 67 which is connected with a shaft 60 by a variable transmission 68, which is only schematically indicated. Bevel gears 71 connect shaft 70 with a shaft 72 which carries spaced bevel gears meshing with bevel gears 73 on the shaft of rollers 31 so that rollers 31 are driven at a speed depending on the ratio of the variable transmission 68 which is adjusted by turning hand wheel 57b.

Main shaft 50 also carries a chain wheel 54 connected by a chain 55 to a chain wheel 56 whose shaft is connected by a variable transmission 58 to the shaft of another chain wheel 60 connected by a chain 61 with chain wheel 62 on shaft 12. A hand wheel 57a is used for adjusting the transmission ratio to select the speed of shaft 12.

Transporting means 20 transports the yarn slippage free at a high speed out of the stretching area and into the shrinking area. The speed of shaft 12, and thereby of transporting means 10 is adjusted by hand wheel 57a so that the yarn is stretched a predetermined amount in the stretching area. The speed of the transporting means 30 is adjusted by hand wheel 57b to be lower than the speed of transporting means 20, so that the yarn can shrink a predetermined amount in the shrinking area while heat is applied to the yarn by the heating device 25. By suitably selecting the number of revolutions of rollers 21 and 31, the yarn is permitted to shrink to a final condition, and all yarns will be shrunk the same amount. By adjusting the speed of rollers 11 by hand wheel 57a, the amount of stretching of all yarns will be exactly determined.

The modified embodiment of FIG. 3 operates in the same manner as the embodiment of FIGS. 1 and 2. However, all three transporting means 10, 20, 30 are constructed in the manner of transporting means 20 and 30 in the first embodiment. Each transporting means includes a driven roller 17, 21, 31 of greater diameter cooperating with a roller 18, 22, 32 of smaller diameter, whose axis is inclined to the axis of the respective driven roller. A heating device 19 is provided in the stretching area between transporting means 10 and 20, and another heater 25 is provided in the shrinking area between transporting means 20 and 30.

A motor 45 drives the shaft 76 of roller 21, and carries a bevel gear meshing with another bevel gear which is coaxially secured to a spur gear which forms part of the gear train 85 including a bevel gear driving a bevel gear on the shaft of roller 17. Gears 86a and 86b are change gears permitting a variation of the transmission ratio between shaft 76 and roller 17 so that the speed of roller 17 can be selected to obtain the desired amount of stretching.

Shaft 76 carries a gear 77 meshing with a gear 79 which drives a chain wheel 80 connected by chain 81 to a chain wheel 82 which drives transporting roller 31. A bevel gear drive device 75 is connected with chain wheel 82 to drive transporting rollers 31 of the other paths.

While in the embodiment of FIGS. 1 and 2, the shrunk yarn is wound as a package on a tube by a ring twisting apparatus, the yarn is wound on a frusto-conical core by a cross-winding apparatus including a cylinder 40 with cross grooves in the embodiment of FIG. 3. The conventional winding apparatus is only schematically indicated.

Various types of slippage free transporting means may be used, for example the transporting means of the stretching area may be a stepped draw roller.

It is important that the temperatures applied by heating devices 19 and 25 are exactly adjusted. Conventional temperature regulators and thermostats may be used for

this purpose. The temperatures required in the stretching areas and in the shrinking areas are different, and the exact temperature in each area depends on several factors, particularly on the material of which the yarn is made and of the velocity of the yarn. The exact temperatures, particularly the temperature of the heating device 25 can be determined by a few trials, and the same is true for the amount of shrinkage of the yarn in the shrinking area which can be determined by a few tests to determine the speeds of rollers 21 and 31 at which the shrunk yarn will no further shrink after being wound up.

The heating devices may be of any suitable construction permitting the heating of the moving yarn to a desired temperature. However, it is particularly advantageous to use a heating device with a cylindrical channel through which the moving yarn passes, and to apply heat to the portion of the yarn passing through the channel.

Preferred embodiments of heating devices according to the invention are now described with reference to FIGS. 4 to 7 and 8 to 11. A heating device according to the invention comprises two segment-shaped bodies containing electric heating wires and being movable between a closed position forming a central channel for the yarn, and an open position permitting insertion and removal of the yarn from the heating device.

By opening the heating device along its entire length, not only the operation of the machine is facilitated, but it is also possible to stop the application of heat to the yarn immediately upon stopping of the transporting means by opening the heating device. When the apparatus has been started and the yarn is being transported, a heating of the yarn can be momentarily started by closing of the heating device.

Referring now to the heating device illustrated in FIGS. 4 to 7, a cylindrical body 25 is divided into two segment-shaped parts which form in the closed position of FIG. 4 a cylindrical channel 100 whose axis coincides with the axis of cylinder 25. Yarn channel 100 is surrounded by a divided tubular heating body 101 which is heated by heating element 103 in the form of electric resistance wires. The outer layer of the cylindrical body 25 is also divided and consists of thermo insulating material. The two heater segments 92 and 93 are symmetrically constructed and connected to each other for pivotal movement by a hinge joint 107, 108, as best seen in FIG. 7. When the heater segments 92, 93 are opened, as shown in FIG. 5, the yarn channel 100 is fully opened and accessible.

Each heater segment 92, 93 has a projecting bracket to which links 109a, 109b are articulated respectively. The other ends of links 109a, 109b are articulated to an operating member 111 which includes a sleeve mounted for sliding movement on a control shaft 113. A spring 123 abuts at one end a flange 124 fixed on control shaft 113 and on the other end on operating member 111 to urge the same into a position abutting another fixed flange 125 so that the heating device 25 is closed, as shown in FIG. 4. When operating member 111 is moved against the action of spring 123 away from flange 125 in the direction of the arrow A, links 109a, 109b open the heating device, as shown in FIG. 5. Control shaft 113 has an annular groove 130 into which a locking member 128 snaps to hold the heating device in the open position. A spring 127 abutting operating member 111 and a flange on locking member 128 urges the same toward the locking position, and when closing of the heating device is desired, locking member 128 is retracted by handle 129 so that spring 123 shifts operating member 111 with locking member 128 to the position of FIG. 4 to close the heating device.

It has been explained with reference to FIG. 1 that a plurality of yarns move along the plurality of paths in which the heating devices 25 are located. Control shaft 113, not shown in FIG. 1, extends parallel to main shaft

50 and is connected by operating members 111 and links 109a, 109b to each of the heating devices 25. When the control shaft 113 is shifted in the direction of the arrow B in FIG. 6, all operating members 111 are displaced toward the left common with the control shaft 113 by means of entrainer disc 125 as viewed in FIG. 6 and open the respective heating devices simultaneously. By shifting control shaft 113 in the opposite direction, all heating devices 25 are permitted to close.

The heating device 25 of the embodiment of FIGS. 8 to 11 is constructed of two segment-shaped halves as explained with reference to FIG. 4. However, the segment-shaped halves are not connected by a pivot joint, but move toward and away from each other along a straight path determined by a guide pin 115 located in corresponding bores of the heater segments 92 and 93. Operating member 111 has a sleeve portion mounted on control shaft 113, and spring 123, flanges 124, 125, locking member 128, spring 127 are constructed as described with reference to the embodiment of FIGS. 4 to 7.

However, the operating member 111 has two guide slots 121 in which guide pins 119 are located which project from a pair of levers 117a, 117b articulated to brackets on heater segments 92, 93, and pivotally connected to each other by a pivot pin 118.

When operating member 111 is moved to the left as viewed in FIG. 8, spring 123 is compressed, and the guide means 119, 121 force lever arms 117a, 117b apart so that the heater segments 92, 93 are separated and assume the open position shown in FIG. 9. Locking member 128 locks the device in this open position by engaging annular groove 130 in control shaft 113. When locking member 128 is released by handle 129, spring 123 closes the heating device.

When all heating devices are to be simultaneously opened, control shaft 113 is shifted to the left as viewed in FIG. 8 so that all operating members 111 on control shaft 113 are shifted to the left and the lever arms 117a, 117b are spread apart to open all heating devices 25.

The heating devices illustrated in FIGS. 4 to 11 cannot only be used in the shrinking areas, but can also be provided in the stretching areas as explained with reference to FIGS. 1 to 3.

It will be understood that each of the elements described above, or two or more together, may also find a useful application in other types of methods of shrinking a yarn differing from the types described above.

While the invention has been illustrated and described as embodied in a method and apparatus for stretching, shrinking, and winding up a synthetic yarn in a continuous operation, it is not intended to be limited to the details shown, since various modifications and structural changes may be made without departing in any way from the spirit of the present invention.

Without further analysis, the foregoing will so fully reveal the gist of the present invention that others can by applying current knowledge readily adapt it for various applications without omitting features that, from the standpoint of prior art, fairly constitute essential characteristics of the generic or specific aspects of this invention and, therefore, such adaptations should and are intended to be comprehended within the meaning and range of equivalence of the following claims.

What is claimed as new and desired to be secured by Letters Patent is:

1. An apparatus for stretching and shrinking a yarn, comprising at least one first transporting means for transporting the yarn at a predetermined first speed into a stretching area; at least one second transporting means for transporting the yarn at a predetermined second speed higher than said first speed out of said stretching area, and into a shrinking area, said second transporting means being located between said stretching and shrinking areas spaced a predetermined distance from said first transporting means, and said first and second speeds being selected

so that said yarn is stretched a predetermined amount in said stretching area; heating means in said shrinking area for heating said yarn in said shrinking area, said heating means including a heating body divided into a plurality of heater members, each heater member having a groove, said heater members having an abutting position in which said grooves form a central channel for guiding said yarn and having an axis of symmetry, at least one of said heater members being movable away from and toward said axis; and operating means for moving at least said one heater member to a position in which said channel is open along the entire axial length thereof; and at least one third transporting means spaced a predetermined distance from said second transporting means for transporting said heated yarn at a predetermined third speed lower than said second speed out of said shrinking area, and selected so that said yarn is shrunk a predetermined amount in said shrinking area.

2. An apparatus according to claim 1 wherein said first, second, and third transporting means are positioned so that a single shrinking area is located directly adjacent said stretching area.

3. An apparatus according to claim 1 wherein said first, second and third transporting means are aligned so that said yarn is transported along a straight path through said stretching and shrinking areas.

4. An apparatus according to claim 1 wherein said second transporting means transport the yarn at the same predetermined second speed out of said stretching area and directly into said shrinking area.

5. An apparatus according to claim 1 wherein said heating body is a circular cylinder divided into two heater segments constituting said heater members, each heater segment having an axially extending groove forming said channel in an abutting operative position of said heater segments.

6. An apparatus according to claim 5 and including means mounting said heater segments for simultaneous movement toward and away from each other.

7. An apparatus according to claim 6 wherein said mounting means include a joint for connecting said heater segments for angular movement toward and away from each other.

8. An apparatus according to claim 6 wherein said mounting means include means for guiding said heater segments for movement along a straight path toward and away from each other.

9. An apparatus according to claim 6 wherein said operating means includes at least one operating member, and linkage means connecting said operating member with said heater segments for moving the same toward and away from each other.

10. An apparatus according to claim 9 wherein said operating means include resilient means for urging said operating member to an end position in which said heater segments abut each other.

11. An apparatus according to claim 10 and including locking means for locking said operating member in another end position in which said heater segments are spaced from each other.

12. An apparatus according to claim 5 including a plurality of first, second, and third transporting means respectively forming parallel paths for transported yarn, each path having a stretching area and a shrinking area; wherein said heating means is provided in each shrinking area; and including a control member extending across

said paths and supporting the operating members of said heating means for sliding movement between said end positions; and means connecting said control member with said operating members so that said operating members can be simultaneously moved by operation of said control member between said end positions for moving said heater segments between abutting and spaced positions.

13. A heating device for a longitudinally moving elongated element, comprising a heater body including two body halves having abutment faces and being movable between a spaced position and an abutting position in which said abutment faces abut each other, each body half having in said abutment face a longitudinal groove, said grooves forming a channel in said abutting position for the passage of a yarn, each body half including electric heating means surrounding said channel in said abutting position; and operating means for moving said body halves between said abutting and spaced positions.

14. A heating device according to claim 13 wherein said operating means include an operating member and linkage means connecting said operating member with said body halves, said operating member being movable between two end positions in which said body halves are in said abutting and spaced positions, respectively.

15. A heating device according to claim 14 wherein said operating means include spring means for urging said operating member to one end position; and locking means for locking said operating member in the other end position.

16. A heating device for a longitudinally moving elongated element, comprising heating means divided into a plurality of heater members, each heater member having a groove, said heating members having an abutting position in which said grooves together form a central channel for guiding said elongated element, said central channel having an axis; mounting means for mounting at least one of said heater members for movement away from and toward said axis; and operating means for moving at least said one heater member to a position in which said channel is open along the axial length thereof.

17. Heating device as claimed in claim 16 wherein said operating means include an operating member and linkage means connecting said operating member with all said heater members for moving the same toward and away from each other.

18. Heating device as claimed in claim 17 wherein said operating means include resilient means for urging said operating member to an end position in which said heater members are in said abutting position.

19. Heating device as claimed in claim 18 and comprising locking means for locking said operating member in another end position in which said heater members are spaced from each other.

#### References Cited

##### UNITED STATES PATENTS

2,208,497	7/1940	Coleshill et al. ....	28—71.3 X
3,031,770	5/1962	Githens et al. ....	28—62 X
3,046,632	7/1962	Tsutsumi .....	28—62 X
3,069,836	12/1962	Dahlstrom et al. ...	28—71.3 X

##### FOREIGN PATENTS

773,816 5/1957 Great Britain.

LOUIS K. RIMRODT, *Primary Examiner.*