



(43) International Publication Date  
14 February 2013 (14.02.2013)

- (51) International Patent Classification:  
A47F 7/28 (2006.01) A47F 1/04 (2006.01)
- (21) International Application Number:  
PCT/US2012/050009
- (22) International Filing Date:  
8 August 2012 (08.08.2012)
- (25) Filing Language: English
- (26) Publication Language: English
- (30) Priority Data:  
61/521,565 9 August 2011 (09.08.2011) US  
61/618,748 31 March 2012 (31.03.2012) US
- (71) Applicant (for all designated States except US): **GAMON PLUS, INC.** [US/US]; 1601 Lively Blvd., Elk Grove Village, IL 60007 (US).
- (72) Inventors; and  
(75) Inventors/Applicants (for US only): **JOHNSON, Terry J.** [US/US]; 1 E. Schiller, Penthouse, Chicago, IL 60610 (US). **JOHNSON, Trevor Ogden** [US/US]; 1224 W. Van Buren St., #809, Chicago, IL 60607 (US).
- (74) Agent: **TIAJOLOFF, Andrew L.**; Tiajolloff And Kelly LLP, Chrysler Building-37th Fl., New York, NY 10174 (US).

(81) Designated States (unless otherwise indicated, for every kind of national protection available): AE, AG, AL, AM, AO, AT, AU, AZ, BA, BB, BG, BH, BN, BR, BW, BY, BZ, CA, CH, CL, CN, CO, CR, CU, CZ, DE, DK, DM, DO, DZ, EC, EE, EG, ES, FI, GB, GD, GE, GH, GM, GT, HN, HR, HU, ID, IL, IN, IS, JP, KE, KG, KM, KN, KP, KR, KZ, LA, LC, LK, LR, LS, LT, LU, LY, MA, MD, ME, MG, MK, MN, MW, MX, MY, MZ, NA, NG, NI, NO, NZ, OM, PE, PG, PH, PL, PT, QA, RO, RS, RU, RW, SC, SD, SE, SG, SK, SL, SM, ST, SV, SY, TH, TJ, TM, TN, TR, TT, TZ, UA, UG, US, UZ, VC, VN, ZA, ZM, ZW.

(84) Designated States (unless otherwise indicated, for every kind of regional protection available): ARIPO (BW, GH, GM, KE, LR, LS, MW, MZ, NA, RW, SD, SL, SZ, TZ, UG, ZM, ZW), Eurasian (AM, AZ, BY, KG, KZ, RU, TJ, TM), European (AL, AT, BE, BG, CH, CY, CZ, DE, DK, EE, ES, FI, FR, GB, GR, HR, HU, IE, IS, IT, LT, LU, LV, MC, MK, MT, NL, NO, PL, PT, RO, RS, SE, SI, SK, SM, TR), OAPI (BF, BJ, CF, CG, CI, CM, GA, GN, GQ, GW, ML, MR, NE, SN, TD, TG).

Published:  
— with international search report (Art. 21(3))

(54) Title: ERGONOMIC BOTTLE DISPLAY

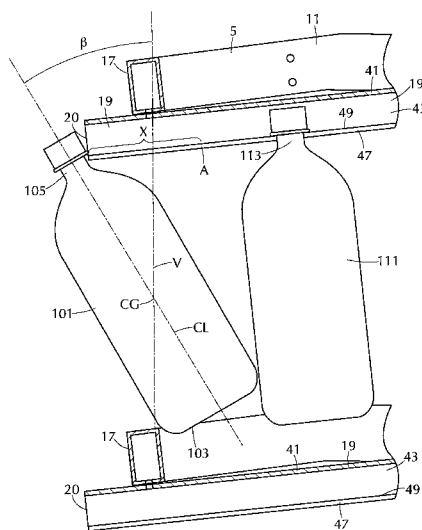


FIG. 13

(57) Abstract: A product display displays bottles each suspended by its neck. The apparatus is usually a rack display with several shelf frames that each has a number of sliding bottle support structures with left and right slide structures spaced laterally so as to define a slot of substantially uniform width over at least a lengthwise portion of the slide structures. That width is such that the necks of the bottles extend upwardly through the slot and a widened portion of the bottle's neck rests on both the slide structures and slides forward and rearward. The left and right slide structures in the lengthwise portion are inclined forwardly and downwardly at a downward angle relative to level that is in a range of 3 to 7 degrees. Friction between the bottles and the slide structures is low enough that the bottles, by virtue of their weight, slide forwardly on the slide structures. A lower frame shelf provides a bumper rail that prevents the bottles in the shelf rack above from sliding off the front end of the slide structure.

**ERGONOMIC BOTTLE DISPLAY****[0001] Related applications**

[0002] This application claims the priority of U.S. provisional patent application serial number 61/618,748 filed March 31, 2012, and U.S. provisional patent application serial number 61/521,565 filed August 9, 2011, both of which are herein incorporated in their entirety by reference.

**[0003] Field of the Invention**

[0004] The present invention relates to product displays and dispensers and, more particularly, to gravity feed displays for bottles of liquid, such as beverages.

**[0005] Background of the Invention**

[0006] Liquids, particularly beverages, are frequently sold in bottles of a plastic material or glass material. Where plastic material is used, commonly the bottle has a body configured to accommodate as much liquid as possible, and a neck extending upwardly therefrom that is sealed with a bottle cap. In plastic bottles particularly, the bottle neck is frequently provided with a flange that extends radially outward from the cylindrical bottle neck a short distance, and is located just below the lower end of the bottle cap when screwed on top of the bottle.

[0007] Numerous display racks exist for supporting bottles of this type for retail display. Use of shelves is undesirable, because the bottles are pushed to the back easily, and have to be brought forward manually for consumers to access them.

[0008] To overcome this, displays, such as the system shown in U.S patent no. 5,586,665, support bottles suspended on racks that are tilted so that the bottles slide toward the front of the display. These systems, however, usually involve a complex structure to prevent the bottles sliding forward altogether off the front end of the rack that makes loading of the bottles difficult or increases the cost of the display unnecessarily.

[0009] **Summary of the Invention**

[0010] It is accordingly an object of the invention to provide a display apparatus that overcomes the deficiencies of the prior art.

[0011] A product display apparatus according to an aspect of the invention, displays a plurality of bottles each having a respective neck with a first width at a first height of the bottle and a wider portion thereabove. The apparatus comprises a sliding bottle support structure including left and right slide structures spaced laterally so as to define a slot of substantially uniform width over at least a lengthwise portion of the slide structures. The uniform width is such that the necks of the bottles extend upwardly through the slot and the widened portion rests slidingly on both the slide structures for forward and rearward sliding movement thereon. The left and right slide structures in the lengthwise portion are inclined forwardly and downwardly at a downward angle relative to level that is in a range of 3 to 7 degrees. The angle and the materials of the slide

structures are such that friction between the bottles and the slide structures is low enough that the bottles by virtue of weight thereof slide forwardly on the slide structures.

[0012] According to another aspect of the invention, a display apparatus comprises a pair of vertical pillars each supporting a respective upper and lower frame structures. Each frame structure includes a pair of laterally spaced side arms each supported on a respective one of the pillars at a height selected from a plurality of vertical positions so that the upper frame is above the lower frame. Each frame further comprises first and second cross members supported on and extending laterally between the side arms. A first inclined sliding support member is supported on the cross members and includes a pair of laterally-spaced upwardly-disposed inclined sliding tracks of high-impact polystyrene having about 10% silicone therein supported on the cross members and extending slopingly forward and downward at an incline angle of approximately 5 degrees and defining a slot therebetween. A plurality of bottles is supported on the sliding tracks, the bottles each having a neck portion extending through the slot and a neck flange wider than the slot resting slidingly on the tracks with friction between the flange and the sliding tracks being low enough that the weight of each of the bottles causes the bottle to move slidingly forward along the sliding tracks toward a forward terminal end thereof. The lower frame is at a height such that the first cross member thereof engages a lower portion of a forwardmost one of the bottles on the upper frame and prevents forward movement of the bottle to the forward terminal end of the sliding tracks thereof.

[0013] Other objects and advantages of the invention will become apparent from the specification herein.

[0014] **Brief Description Of The Drawings**

[0015] FIG. 1 is an isometric view of illustrating one application of the display system of the present invention loaded with bottles.

[0016] FIG. 2 is a side elevational view of the display of FIG. 1.

[0017] FIG. 3 is an isometric view showing the bottom two frame units shown without the support and supporting a plurality of bottles.

[0018] FIG. 4 is a front view of the two frames of FIG. 3.

[0019] FIG. 5 is a view taken through plane A-A of FIG. 4.

[0020] FIG. 6 is a side view of the frames of FIG. 3, 4 and 5 with the bottles removed.

[0021] FIG. 7 is a view as in FIG. 3, with the bottles removed, and with a portion of the sliding supports removed to show the connection to the supporting frame structure.

[0022] FIG. 8 is a detailed front end view from a forward end of a support member.

[0023] FIG. 9 is a detailed front end view of the sliding support member supporting a bottle.

[0024] FIG. 10 is a detailed isometric view of a support of the adjustable stop structure of the lower frame.

[0025] FIG. 11 is a detailed isometric view of a portion of the frame structure showing the connection between the side arm and the rear cross beam.

[0026] FIG. 12 is a detailed cross-sectional side view of the rack through one of the support members, showing the support of bottles on the rack of the preferred embodiment.

[0027] FIG. 13 is a view as in FIG. 12, showing the forwardmost bottle during loading into or removal from the display rack.

[0028] FIG. 14 is a perspective view of an alternate embodiment of support member.

[0029] FIG. 15 is an exploded detail plan view of the corner structure shown in FIG. 11.

[0030] FIG. 16 is a rearward looking vertical sectional view of the top of the adjustable support shown in FIG. 10.

[0031] **Detailed Description**

[0032] As best seen in FIG. 1, a display rack 1 is provided to support a number of bottles 3, which are usually plastic bottles containing beverages or other liquid products for sale.

[0033] The bottles 3 are supported on a plurality of vertically-spaced frame structures 5 that are releasably secured at pre-selected heights by connection to side pillars 7 of the display rack, which are in turn rigidly connected to a base 9 that supports the display. Alternatively, the pillars 7 may be fixedly secured to a wall behind the display 1.

[0034] Referring to FIGS. 1 and 2, each of the frames is comprised of a pair of left and right side arms 11, each releasably secured to a pillar 7, pre-selected recesses in pillar 7 that set each frame at a height relative to the frame above and below so as to cooperate with them, as will be described in more detail below. Each frame 5 also comprises a rear cross beam 13, a middle cross beam 15, and a front cross beam 17 extending laterally across between the side arms 11. The frame also includes a plurality of sliding bottle support structures 19 that provide for support of the bottles 3 by the necks of the bottles so that the bottles can slide forward backward and

forward with respect to the display 1. In the embodiment shown, the frames 5 which carry 10 substantially equally spaced sliding support structures or beams 19.

[0035] As best seen in FIG. 3, 5, 6 and 7, sliding support structures 19 are essentially straight extruded members of constant cross-section that are inclined downwardly at a constant angle extending forward and downward relative to the display 1 to a terminal end at the front of the display 1. The bottles 3 are supported in the sliding support structures 19 so that the widened flange part of their necks rests on sliding tracks in the support structure 19 so that the bottles can slide forward and backward on it. In the embodiment shown the number of bottles on each sliding support structure 19 is six, but obviously a different number may be employed. The bottles can be loaded on the members 19 as deep as desired, the main consideration being the combined weight of the row of bottles and how difficult it is to push them back and load the rack.

[0036] The angle of the sliding support structures 19, and the structure and materials thereof are such that the bottles 3 supported by their necks, by virtue solely of the weight of the bottles, which overcomes the amount of friction involved, slide on the structure 19 forwardly toward its front terminal end, so that the bottles are biased by gravitational force to move toward the front of the display stand.

[0037] The bottles are prevented from sliding completely off the front ends of the support structures 19 by the fact that before the neck of the forwardmost bottle reaches the end of the support member 19, the lower end portion of the forwardmost bottle 3 on each support structure 19 encounters the front rail 17 of the frame 5 below the frame that supports the bottle 3. The lowermost rack 5 has no rack below it and is therefore provided with a front rail armature 21 that

extends downwardly therefrom and across the display device 1 at a height such that it also engages the lower end of the forwardmost of the bottles 3 supported by that rack 5 so that it stops moving forward.

[0038] The forward terminal end of the support members 19 extends at a length beyond the stopping point at which the neck stops when the bottom of the bottle abuts the front rail 17. To remove the forwardmost bottle from the rack, a person tilts the bottle forward until the widened flange of the bottle neck reaches the terminal end 20 of the support member 19 and passes out of it. At the same time, the bottom of the bottle clears the top of the associated front rail 17, and the bottle is removed easily from the rack. The terminal end 20 extends forward of that point by a distance such that the bottle must be tilted forward to about 30 degrees from vertical before the neck leaves the member 19 and the bottom clears the front rail 17. Geometrically, it is best if the bottle clears the rail 17 before its neck ceases to be supported in the channel member 19, i.e., the terminal end 20 of the member 19 extends further forward than the location thereon supporting the bottle neck when the bottle bottom is high enough to pass over the rail 17.

[0039] FIG. 3 shows the two lower racks 5 of display 1 loaded with bottles 3 with the pillars 7 and surrounding structure removed to show parts of the apparatus. FIGS. 6 and 7 show the structure of FIG. 3 without the bottles to better illustrate the structure of the frames 5.

[0040] Referring to FIG. 7, the upper frame 5 has two parallel left and right side arms 11 which are formed of plate or sheet metal and project parallel forward from the rear of the rear thereof. The rear portion generally indicated at 23 of the arms is provided with an interlocking structure that detachably is inserted into a row of slots in the pillar 7, not shown.

[0041] The interlocking structure includes a series of hooks 24 of a standard configuration for insertion into a vertical slot row as in the standard pillar 7, which are all well known in the art. The top mounting hook 22 is configured with an upward protrusion that requires the side arm 11 to be tilted with its front end upwardly for insertion or removal of the arm 24 to or from the pillar.

[0042] Insertion of the arm 11 into the slots of pillar 7 is accomplished by tilting the front end upward, inserting the top protrusion of top hook 22 into the topmost slot to be connected, and then lowering the arm 11 to near level position in which all protrusions 22 and 24 can be and are inserted into the slots in pillar 7. The arm 11 is then pressed downward and the protrusions 22 and 24 all have downward disposed recesses that catch on the slots and hold the arm 11, and the attached frame 5, out in a cantilever fashion.

[0043] Tubular front rail 17 extends horizontally between the forward end terminal portions 25 of side arms 11, to which it is welded at both ends. Center cross arm 15 is attached fixedly to a connection structure generally indicated at 27 which secures the cross member 15 against upward and downward movement. The rear cross member 13 receives a connection structure as will be described herein and is fixedly secured by a pressure fit to extend perpendicularly between the rearward end portions 23 of the arms 11.

[0044] The front rail stop structure 21 for the lowermost frame 5 is shown in greater detail in FIG. 6 and 7. The structure comprises an L-shaped member 29 having an upper end 30 connected releasably and adjustably to the inside wall of the side arm 11. The L-shaped member 29 extends generally vertically and perpendicularly to the side arm 11 downward and then generally horizontally forward of the display rack 1 to a terminal end 31 to which it is secured to

the tubular cross member 33 that extends perpendicularly between the ends 31 of the side arms 11. This L-shaped structure 29 is adjustable vertically, so that it may be held at different pre-selected heights so that the crossbar 33 may be adjustably positioned in height to function as a stop structure to abut the lower ends of bottles of differing sizes suspended from the sliding support member 19 of the lowermost frame 5.

[0045] Referring to FIG. 5, the side arms 11 support cross beams 13, 15 and 17, all of which are connected with the associated sliding support structure 19. This structure 19 is in the form of a channel shaped beam that extends straight from its rear terminal end to its forward terminal end 20. The rearward terminal end 35 is received in conforming openings 34 in cross member 13 as is best seen in FIG. 7, where a portion of the members 19 are removed. The openings 34 are configured to support the end of the beam 19 against downward or lateral movement relative to the rear cross beam 13.

[0046] The beam 19 is straight over its entire length and supported so that it extends forwardly and downwardly at an angle relative to the horizontal upper portion 37 of the side arm 11. The beam 19 is also secured by a screw or other fixed attachment mechanism to cross arm 15, which is a tubular beam, and also to the underside of cross member 17, which is also a tubular member. These beams 13, 15 and 17 are positioned to maintain the angle of the downward slope of the sliding support structure 19.

[0047] Referring to FIG. 8, the beam or sliding support structure 19 is secured to the box tubular cross beam 17, preferably by a bolt extending through an aperture in an upper wall of the beam and secured in the lower wall of tubular cross beam 17. The beam 19 itself is a linear extruded member of constant cross-section of polystyrene material that comprises a generally planar top

wall 41 from which a pair of laterally-spaced vertical side walls 43 extend, downwardly and integrally formed therewith. The side walls 43 have a lower terminal edge 45 that is formed integral with an inwardly extending flange or entrapping portions 47 that extend inwardly and upwardly so as to provide upwardly disposed surfaces 49 that act as a pair of sliding surfaces or rails on which the flared neck flanges of the bottles can hang and slide. Surfaces 49 are sliding surfaces and their frictional characteristics relative to the material and weight of the bottles are such that the bottles slide forward on the inclined beam 19 solely by virtue of their weight.

[0048] The material that the structure 19 is made of is high impact polystyrene. This high impact polystyrene (HIPS) is a material that includes from 5 to 11% silicone, and in the particularly preferred embodiment 10% silicone. Substantially greater than 11% silicone in the HIPS material results in a softer polystyrene beam that might have difficulty supporting the weight of a very large number of bottles suspended therefrom. On the other hand, reducing the amount of silicone substantially below 5% or even 7% silicone increases the friction on the surface of the polystyrene and may prevent the bottles from sliding forward.

[0049] Referring to FIG. 5, it may be seen that the beam 19 (and with it the sliding surfaces 49) is supported at a sloping angle that slopes downward and forward of the apparatus or the display apparatus. This downwardly sloping angle in the embodiment shown is not greater than seven (7) degrees. Higher angles tend to create more downward force applied along the sliding path and make it more difficult to load bottles into the rack. The slope should also not be three degrees or less since the slope would be then insufficient to allow the weight of the bottle(s) to overcome the coefficient of friction between the bottle neck and the sliding surface 49 of the structure 19 and allow the bottle to slide forward. The preferred slope of this angle is five degrees downward which, combined with the material used for beam 19 and the other

parameters, provides for biasing of the bottles 3 towards the front of the display solely based on their weight due to gravity and not due to any other apparatus or movement by an external force, e.g., by a user pulling the bottles forward. Generally, the slope of the sliding surfaces is as low as possible but steep enough that the friction between the bottle and the sliding surfaces of the beam is overcome by the force urging each bottle to slide down the sliding surfaces of the beam. It should also be understood that the angle of slope of the sliding surfaces of the beam 19 is measured when the bottles are not on the rack. When the bottles are loaded, it will produce a slight bend, which in the preferred embodiment is about  $\pm 1$  degree.

[0050] As discussed previously, to prevent the bottles from sliding off the tracks 49 and out of the sliding support structure 19 altogether through the open front end of the beam 19, the lower portion 55 of the bottle encounters a rear portion of the front cross bar 17 of the lower frame 5 just below the frame from which the bottle 53 depends. This contact point is preferably close to the bottom so that it is relatively easy to withdraw the bottle from that position even for a person that is well below the level of the racks 5.

[0051] The front end 57 of the sliding support structures 19 extends substantially beyond the point at which the neck portion 59 of the forwardmost bottle 53 is in contact with the channel 19. The forward end 57 extends substantially beyond this point, and with all the angles requires that a person removing the bottle 53 from the rack 1 is required to tilt the neck 59 forward by about thirty degrees so that it can pass out of the space inside the channel 19 and passes over the stop structure 17. This dimensioning allows for a fairly short person to access a fairly high shelf or rack of bottles.

[0052] This interaction between the bottles of a first frame 5 and the cross beam 17 of the frame 5 just below it is not possible with the lowermost shelf 5. For the bottles in the lowermost shelf, the cross beam structure 21 is provided, which similarly abuts the lower ends 55 of the bottles or the forward most bottle in a way that allows for withdrawal of the bottle by tilting it forward at about thirty degrees so that the neck and the widened portion thereof can pass out through the open front end of extrusion beam 19. The positioning of the front beam 21 is such that the angle is the same for this frame 5 as well.

[0053] All of the bottles in the rack are removed by customers in this way. Similarly, the bottles are each loaded by tilting them forward about 30 degrees, passing the bottom of the bottle over the front beam 17, and then inserting the neck of the bottle into the beam 19.

[0054] Referring to FIG. 9, the details of the interaction between the bottle neck 59 and the channel shaped slide structure 19 are illustrated. The lower portions 47 of beam 19 define therebetween a recess that is wider than a central cylindrical section 61 of the upper part of the bottle. This part of the bottle extends through this recess between those parts. The bottle neck 59 further comprises a radially outwardly projecting flange 63 that projects horizontally outward around the entire circumference of the bottle neck 61. This flange 63 is usually the part of the bottle that rests on the sliding surfaces 49. The bottle is also provided with a cap 65 that is screwed onto the bottle so that usually the lower portion of the bottle cap 65 or the bottle cap structure (such as when there is a security lock on the bottle) engages the top surface of flange 63. The interior of beam 19 is large enough to receive the cap 65 and neck structure of the bottle even with tilting of the bottle for loading and unloading the rack.

[0055] Referring to FIG. 12, the forwardmost bottle 101 slides forward along the inclined sliding support beam 19 urged solely by force of gravity, until its lower portion 103 contacts the cross beam 17, stopping its downward slide. The next bottle 111 behind bottle 101 also slides forward due solely to gravity, suspended by its neck 113 sliding along the sliding surfaces 49 of the beam 19. Bottle 111 slides forward until it pushes against bottle 101, which normally produces a slight tipping forward of bottle 101, with the neck 105 of bottle 101 reaching a stopping point A. This tipping forward is normally at an angle  $\alpha$  relative to the vertical, illustrated by line V, that is approximately the same as the angle  $\alpha_0$  of downward incline from horizontal. Other bottles, not shown, align in parallel resting against the next forward bottle, up to the full capacity of the beam 19 to support bottles.

[0056] As best seen in FIG. 13, the forwardmost bottle 101 is removed from the rack by tilting the bottle 101 forward until the neck 105 passes out of the forward terminal end 20 of channel support beam 19. As the neck 105 clears the end 20, the lower end 103 continues to rest against cross beam 17, to some degree supporting weight of the bottle 101, which is at this point supported only by the hand of the customer or user and its engagement with cross beam 17.

[0057] The terminal end 20 is spaced from the stopping point A by a distance  $x$  that is such that the bottle 101 clears the end when tilted forward with its centerline CL at an angle  $\beta$  of about 30 degrees from the vertical, shown as line V. At this angle  $\beta$ , the center of gravity CG of bottle 101 is above the cross beam 17, which results in weight of the bottle 101 resting on the beam 17. The customer or user then withdraws the bottle 101 forward, and it is lifted over or slides over the cross beam 17.

[0058] Placement of bottles into the rack is similar but in reverse. When a bottle is to be loaded in the rack, the bottle is tilted and inserted in the rack above the cross beam 17. The lower portion of the bottle 101 is pushed against the bottle 111 behind it, pushing bottle 111 upward along the sliding track 49 against the biasing of its weight to slide forward. When the neck 105 reaches the end 20 of the support member 19, the neck 105 is fit into the channel 19 so that the flange of the neck rests on and is slid backward until it reaches the stopping point A, to the positions shown in FIG. 12. Additional bottles may be loaded similarly, pushing the bottles rearward until the maximum number of bottles supportable on the given member 19 are loaded.

[0059] FIGS. 10 and 16 show the connection of the adjustable side arm 21 to the side arm 11. This armature 29 has an upper end 30 that is supported laterally inward of the associated side arm 11, and has a plurality of apertures 70 therein that coaxially receive upwardly extending flat hook structures 71 and 73 as seen in FIG. 10. These hook structures 71 and 73 are able to receive the upper end of the structure 29 and fit securely into a coaxial structure on the device itself. Removal or adjustment of the L-shaped structure 29 is accomplished by simply lifting structure 29 and withdrawing it inward to clear the hooks 71 and 73, and then fitting different apertures 70 in the armature 29 onto the hooks 71, 73.

[0060] Referring to FIGS. 11 and 15, a pressure fit/clip structure secures the rear cross beam 13 to the side arm 11. The rear end of arm 11 has an inwardly extending flange 81 that extends into the interior of the generally U-shaped or channel-shaped structure of the rear crossbeam 13. When pressed into the cross beam 13, flange 81 has laterally extending protrusions 83 that snap into place in apertures 85 in the crossbeam 13, securing the cross beam 13 to the side arm 11.

[0061] The arrangement of the rack can be compressed somewhat vertically by eliminating the cross beam 15 on the lower racks. That is possible if the loads created by the bottles on the rack can be supported by the member 19 supported only by front rail 17 and rear rail 13. In that case, there is additional clearance of the bottles of the higher rack above the sliding member 19 of the rack below, allowing the side arms 11 to be vertically closer together.

[0062] FIG. 14 shows an alternate embodiment of sliding support structure 121. Support structure 121 is similar to the support structures 19 of the previous embodiment, in that it has an inverted generally channel shape with a top wall 123, and two laterally spaced downwardly depending side walls 125. The side walls have straight lower edges 127 that each have an inwardly extending lip 129, that provides a small upwardly disposed surface extending the length of the support member 121. The space defined between the lips 129 is wide enough that the neck of a bottle can extend therethrough, but too narrow to permit exit of the bottle neck flange through the space, as in the previous embodiment.

[0063] The laterally inward edges of the upper surfaces of lips 129 are each provided with a respective linearly straight track of material 131 fused, glued, or fixedly secured by some other method, thereto. The support member 121 is supported as in the previous embodiment by structure that holds it cantilevered out at a downwardly and outwardly inclining angle. The neck flanges of the bottles rest on the tracks 131 and slide downwardly on the tracks 131 by gravity until the forwardmost bottle engages the front rail as described above.

[0064] These tracks 131 are of a material having a lower coefficient of friction than the material of which the rest of the support member 121 is composed. The tracks 131 of the support member 121 are of HIPS containing from 2% to 10% silicone, and most preferably 4% to 6% silicone, or

about 5% silicone. The remainder of the support member 121 is of HIPS containing little or no silicone, which renders the material stronger. The slipperiness of the track material allows a relatively mild incline while the bottles will still slide down the support member on the tracks 131 to the front of the display. The slope of the incline may be less than 8 degrees, and is preferably from 5 to 6.5 degrees.

[0065] The strength of the channel member is enhanced by the walls 123 and 125 being of HIPS containing no silicone or very little silicone. The bending over its length when loaded with bottles is therefore reduced. Also, the channel is strengthened against the possibility of the bottles being somehow twisted so as to pry apart the lower lips 129 and tracks 131 by the use of the stronger HIPS material, and also by a rounding of the corners 133 between the top wall 123 and the side walls 125. The rounded corners have an inside radius of curvature of greater than 0.15, and preferably between 0.2 and 0.35 inches, and most preferably about 0.25 inches. This curvature strengthens the side walls 125 support against the spreading apart of the lips 129.

[0066] The terms used herein should be read as terms of description rather than of limitation. While embodiments of the invention have here been described, persons skilled in this art will appreciate changes and modifications that may be made to these embodiments without departing from the spirit of the invention, the scope of which is set out in the claims.

## WHAT IS CLAIMED IS:

1. A product display apparatus for displaying a plurality of bottles each having a respective neck with a first width at a first height of the bottle and a wider portion thereabove, said apparatus comprising:

a sliding bottle support structure including

left and right slide structures spaced laterally so as to define a slot of substantially uniform width over at least a lengthwise portion of the slide structures,

wherein said uniform width is such that the necks of the bottles extend upwardly through the slot and the widened portion rests slidingly on both the slide structures for forward and rearward sliding movement thereon;

wherein the left and right slide structures in said lengthwise portion are inclined forwardly and downwardly at a downward angle relative to level that is in a range of 3 to 7 degrees;

wherein friction between the bottles and the slide structures is low enough that the bottles by virtue of weight thereof slide forwardly on the slide structures.

2. The apparatus of claim 1 wherein the slide structures are straight inclines with a constant downward angle.

3. The apparatus of claim 1 wherein the slide structures are both part of an inclined beam having a pair of side walls each having a respective one of the slide structures supported thereon and projecting inward of the beam therefrom toward the necks of the bottles.

4. The apparatus of claim 3 wherein the beam is a channel-shaped member made up of the side walls, a planar top wall extending between upper ends of the side walls, and flanges extending inward from lower ends of the side walls, the slide structures being on said flanges, and wherein the top wall is joined to the side walls in a curved connecting portion having a radius of curvature of at least 0.15 inches, and preferably about 0.25 inches.
5. The apparatus of claim 4, wherein the slide structures are on upwardly extending ridges on inward ends of the flanges, the slide structures being of HIPS containing 2% to 10% silicone, and the beam apart from said slide structures being of HIPS containing substantially no silicone, said slide structures being fixedly affixed to the flanges.
6. The apparatus of claim 5, wherein the beam is an extrusion of substantially constant cross section.
7. The apparatus of claim 6, wherein the beam is of high-impact polystyrene (HIPS).
8. The apparatus of claim 7, wherein the high-impact polystyrene (HIPS) contains about 10 percent silicone.
9. The apparatus of claim 1, wherein the slide structures are of high-impact polystyrene (HIPS) containing 5 to 11 percent silicone.
10. The apparatus of claim 1, wherein the downward angle is 5 to 6.5 degrees.
11. The apparatus of claim 1, wherein the display structure includes a stop structure positioned so as to engage a forwardmost one of the bottles so that said bottle slides to a position wherein the bottle is against the stop structure and is prevented from further sliding movement beyond said position.

12. The apparatus of claim 11, wherein the stop structure is adjustably supported relative to the slide structures so as that the stop structure can be moved to a different height for use of the display apparatus with other bottles of different height than said bottles.

13. The apparatus of claim 11, wherein the slide structures extend forwardly to forward terminal ends at which the bottles can be removed therefrom, said terminal ends being positioned relative to the stop structure such that the forwardmost bottle, when tipped forwardly so that the neck thereof is removed from the sliding structures, has a center of gravity vertically above the stop structure, and the bottle can be withdrawn from the apparatus.

14. The apparatus of claim 13, wherein the bottle is tilted at about 30 degrees when the bottle clears the stop structure.

15. The apparatus of claim 11, wherein the slide structures are supported on a frame that extends forwardly from a vertically extending support and is detachably supported thereon.

16. The apparatus of claim 11, wherein the stop structure comprises a laterally extending member supporting thereon a second sliding bottle support structure extending slopingly forward and downward and slidingly supporting widened portion of necks of a further plurality of bottles.

17. The apparatus of claim 11, wherein the sliding bottle support structure is supported on a frame having laterally spaced side arms cantileveredly supported on vertical rear pillars, said stop structure including an armature supported on one of the side arms and a stop member connected with the armature and extending laterally forward of the plurality of bottles, the

armature being supported on the side arm so as to provide adjusting vertical movement thereof and of the stop member.

18. The apparatus of claim 11, wherein the side arms are releasably supported on the pillars, said pillars having a plurality of apertures therein, and the side arms being selectably inserted entrappingly in one or more of said apertures so as to select a height of the side arms.

19. A display apparatus comprising:

a pair of vertical pillars each supporting a respective upper and lower frame structures;

each frame structure including a pair of laterally spaced side arms each supported on a respective one of the pillars at a height selected from a plurality of vertical positions so that the upper frame is above the lower frame;

each frame further comprising

first and second cross members supported on and extending laterally between said side arms;

a first inclined sliding support member supported on the cross members and including a pair of laterally-spaced upwardly-disposed inclined sliding tracks of high-impact polystyrene having about 5 to 13% silicone therein supported on the cross members and extending slopingly forward and downward at an incline angle of approximately 5 degrees and defining a slot therebetween;

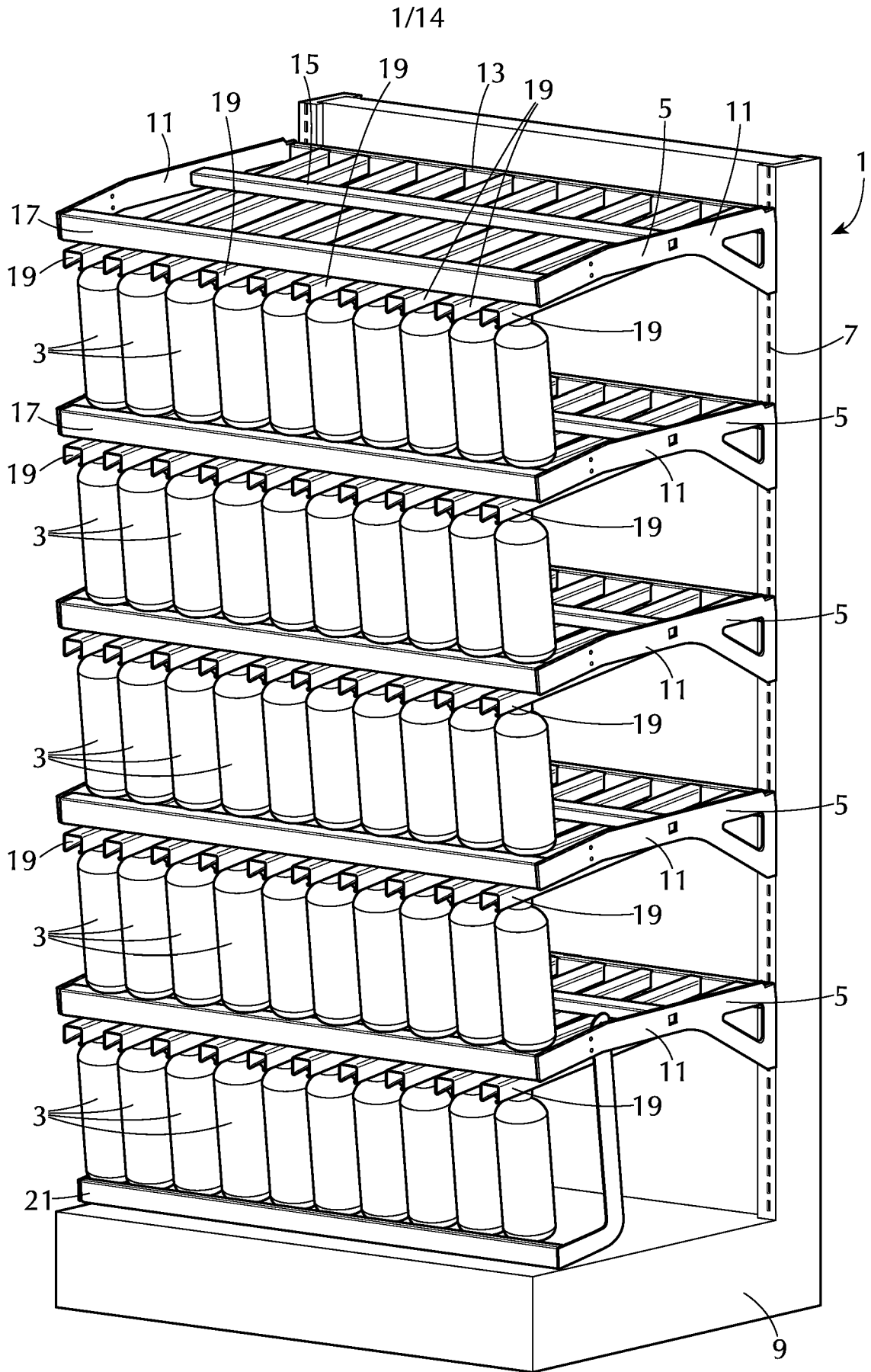
a plurality of bottles supported on the sliding tracks, said bottles each having a neck portion extending through the slot and a neck flange wider than the slot resting slidingly on the tracks with friction between the flange and the sliding tracks being low enough that the weight of

each of the bottles causes said bottle to move slidingly forward along the sliding tracks toward a forward terminal end thereof;

the lower frame being at a height such that the first cross member thereof engages a lower portion of a forwardmost one of the bottles on the upper frame and prevents forward movement of said bottle to the forward terminal end of the sliding tracks thereof.

20. The display apparatus of claim 19, wherein the sliding support member is a linear beam extruded with a constant cross section from high-impact polystyrene having about 10% silicone therein.

21. The apparatus of claim 19, wherein the sliding support member is a linear beam, and the sliding tracks are formed of HIPS containing 2 to 10 percent silicone and the beam except for said sliding tracks is formed of HIPS containing substantially no silicone.



**FIG. 1**

2/14

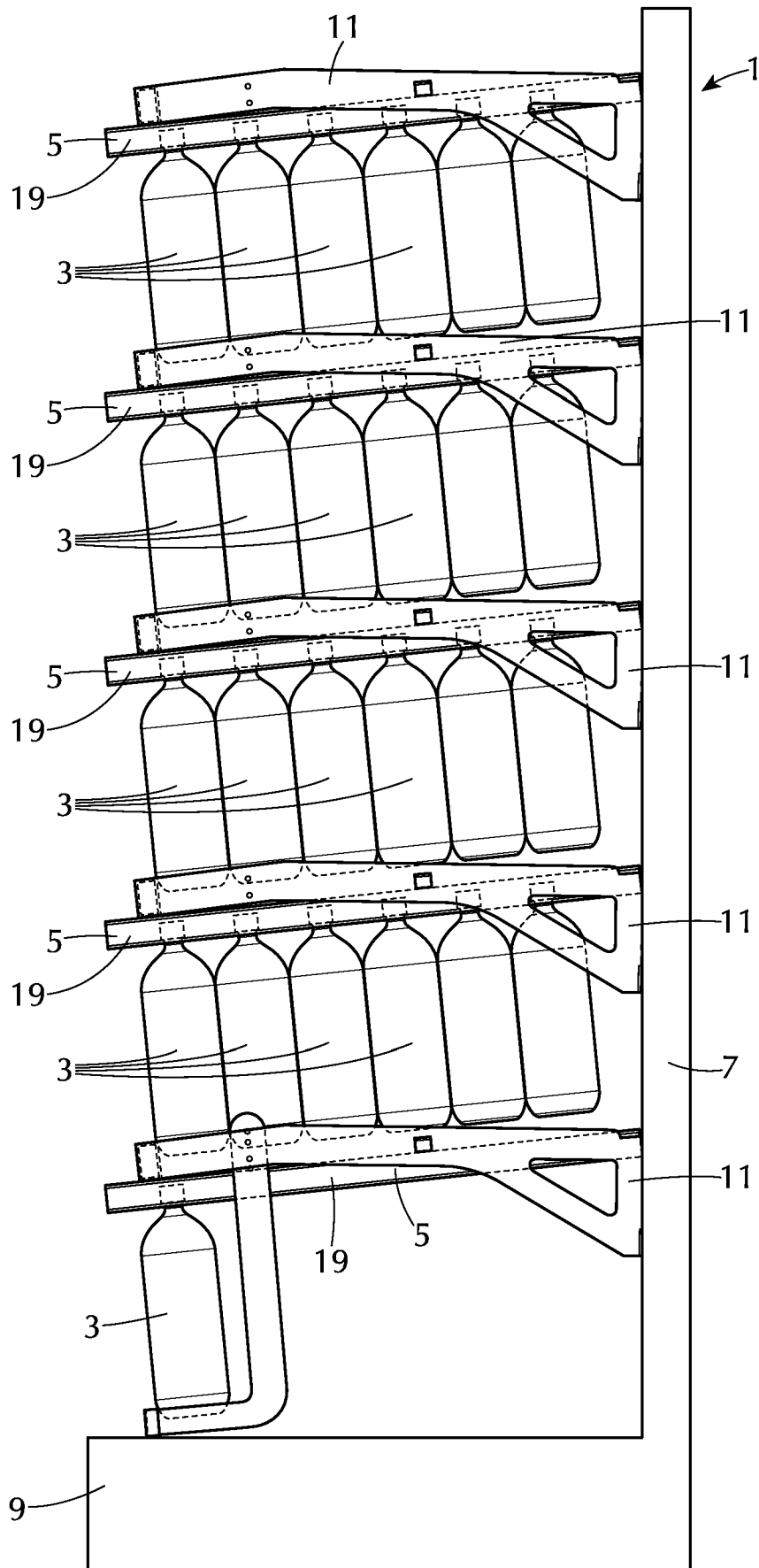


FIG. 2

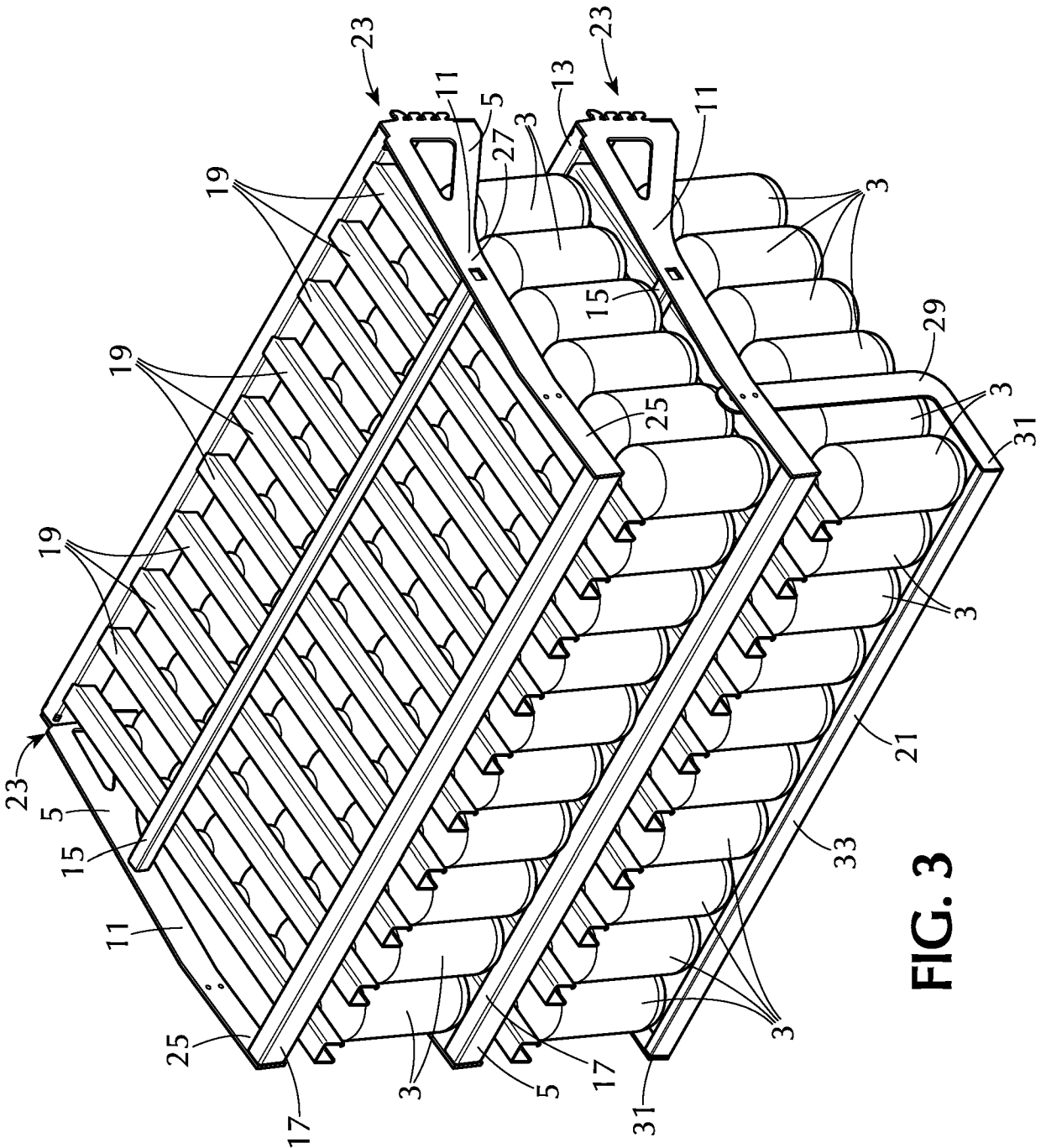


FIG. 3

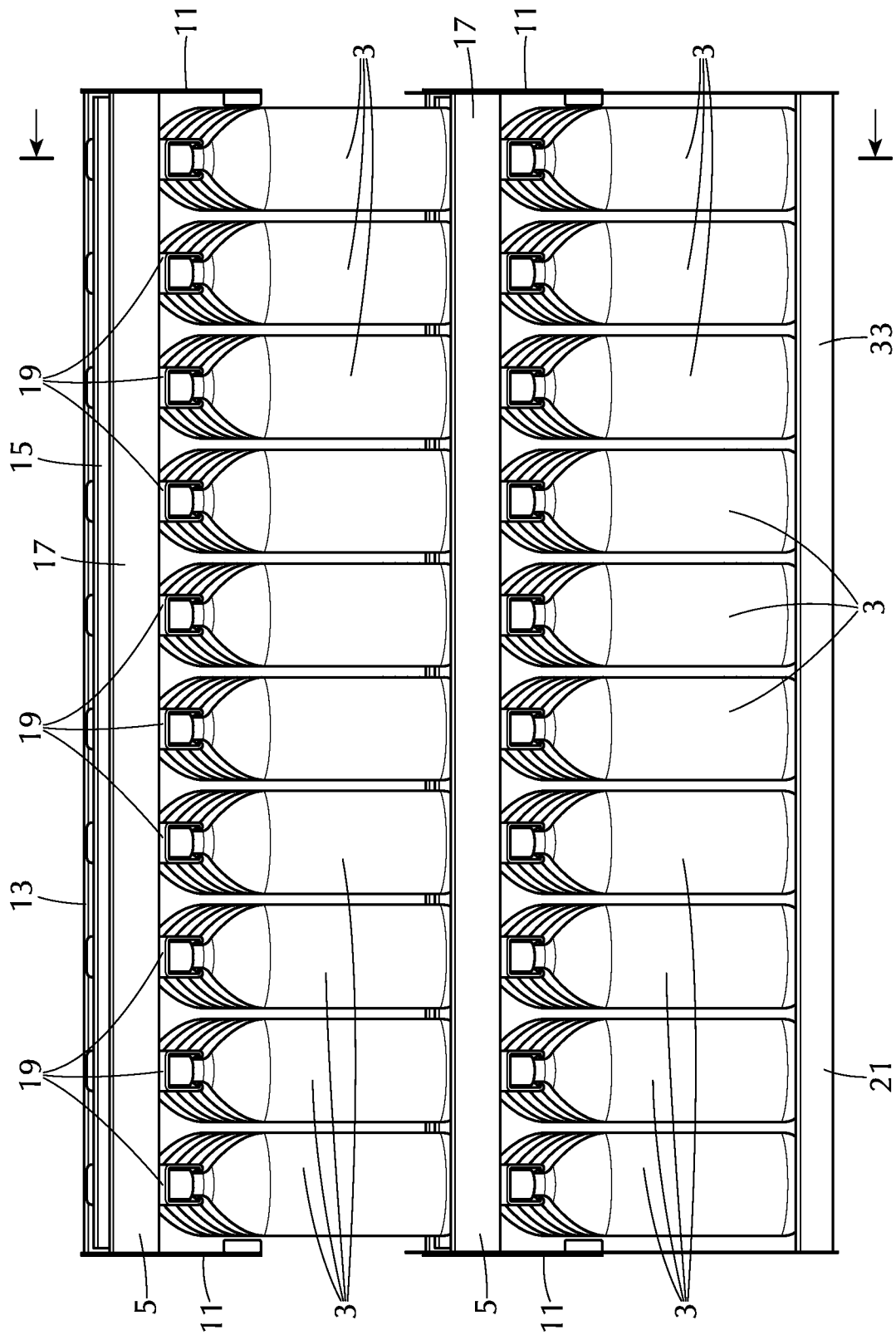


FIG. 4



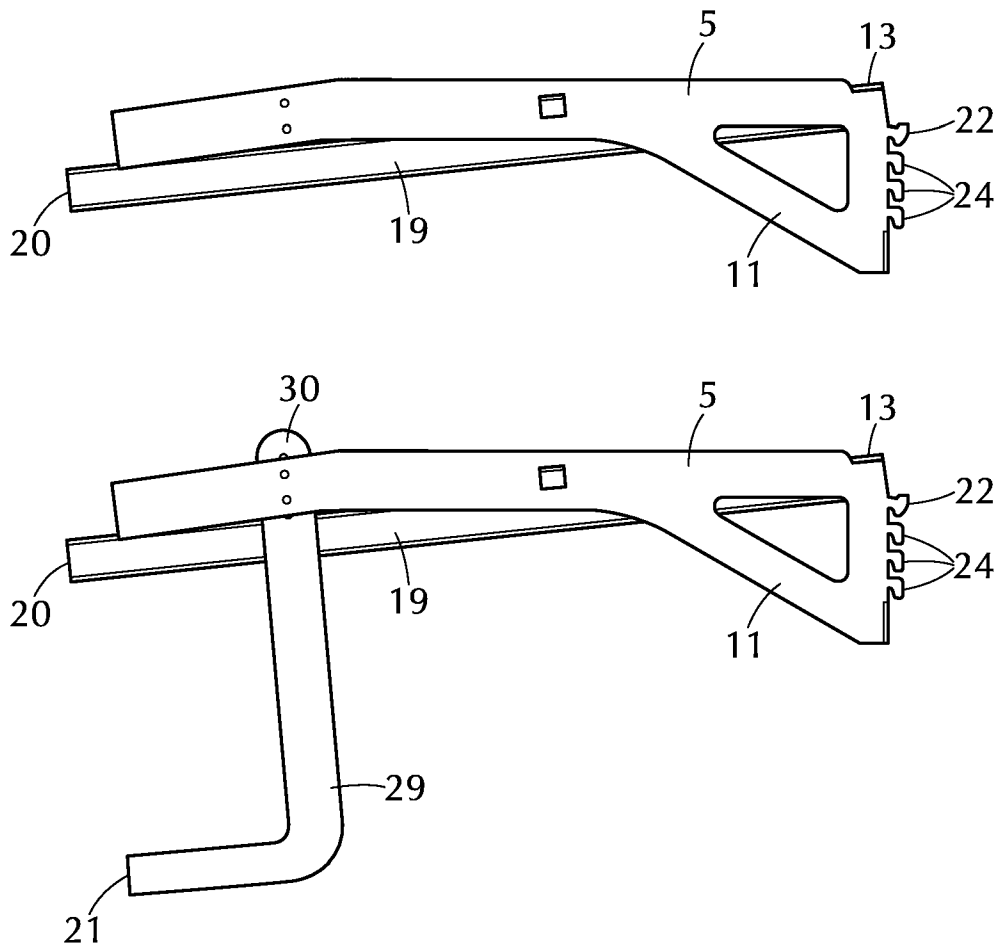


FIG. 6

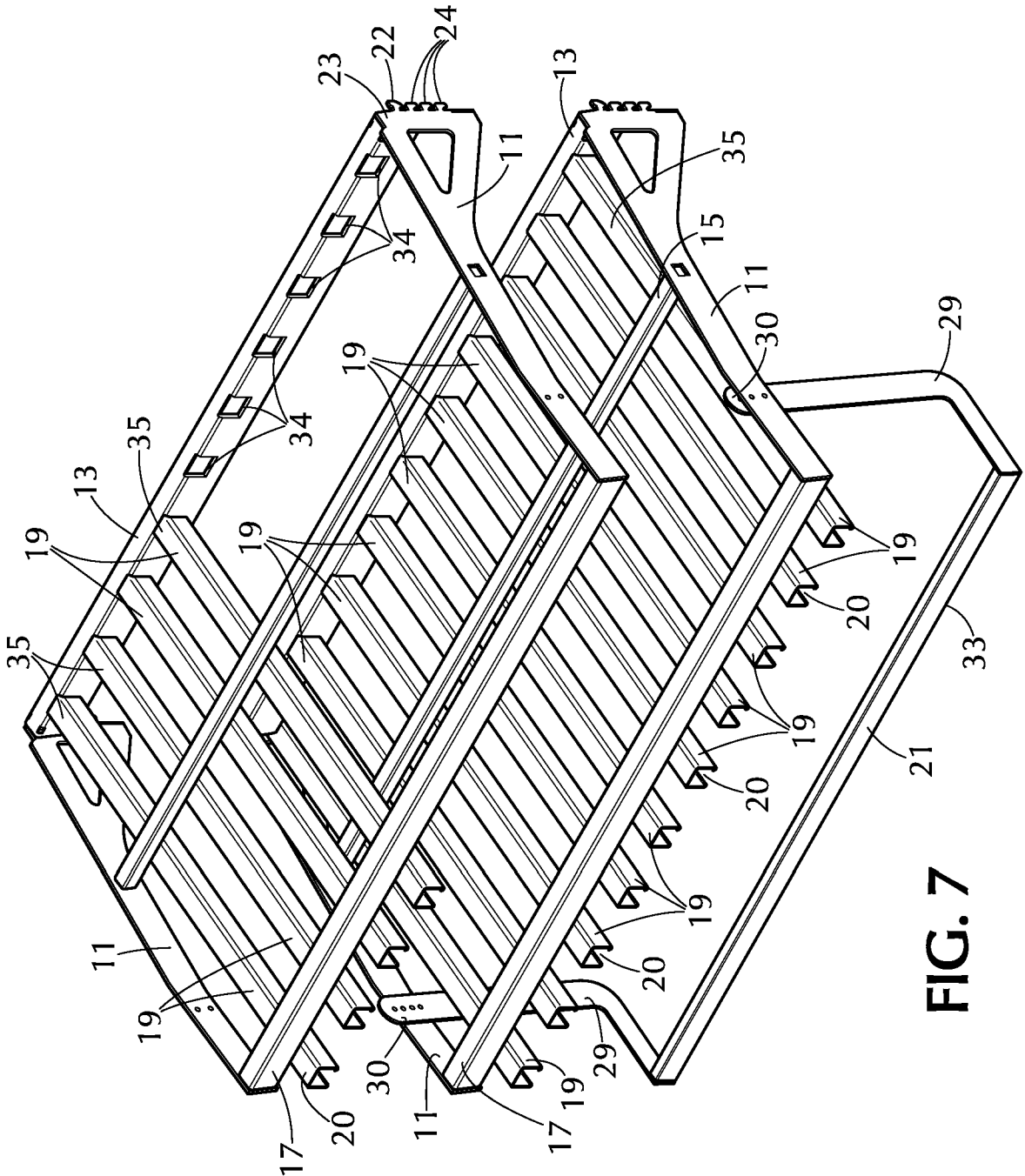
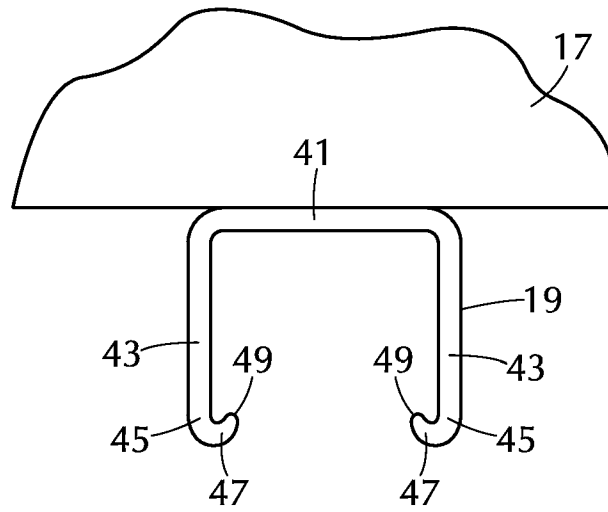
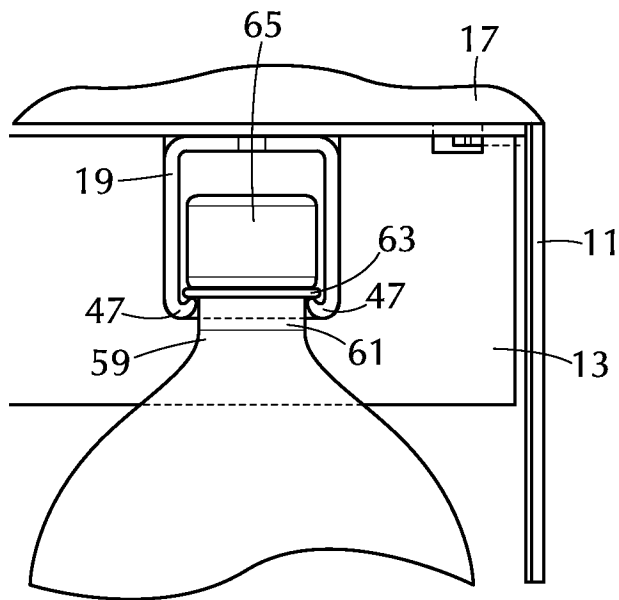


FIG. 7

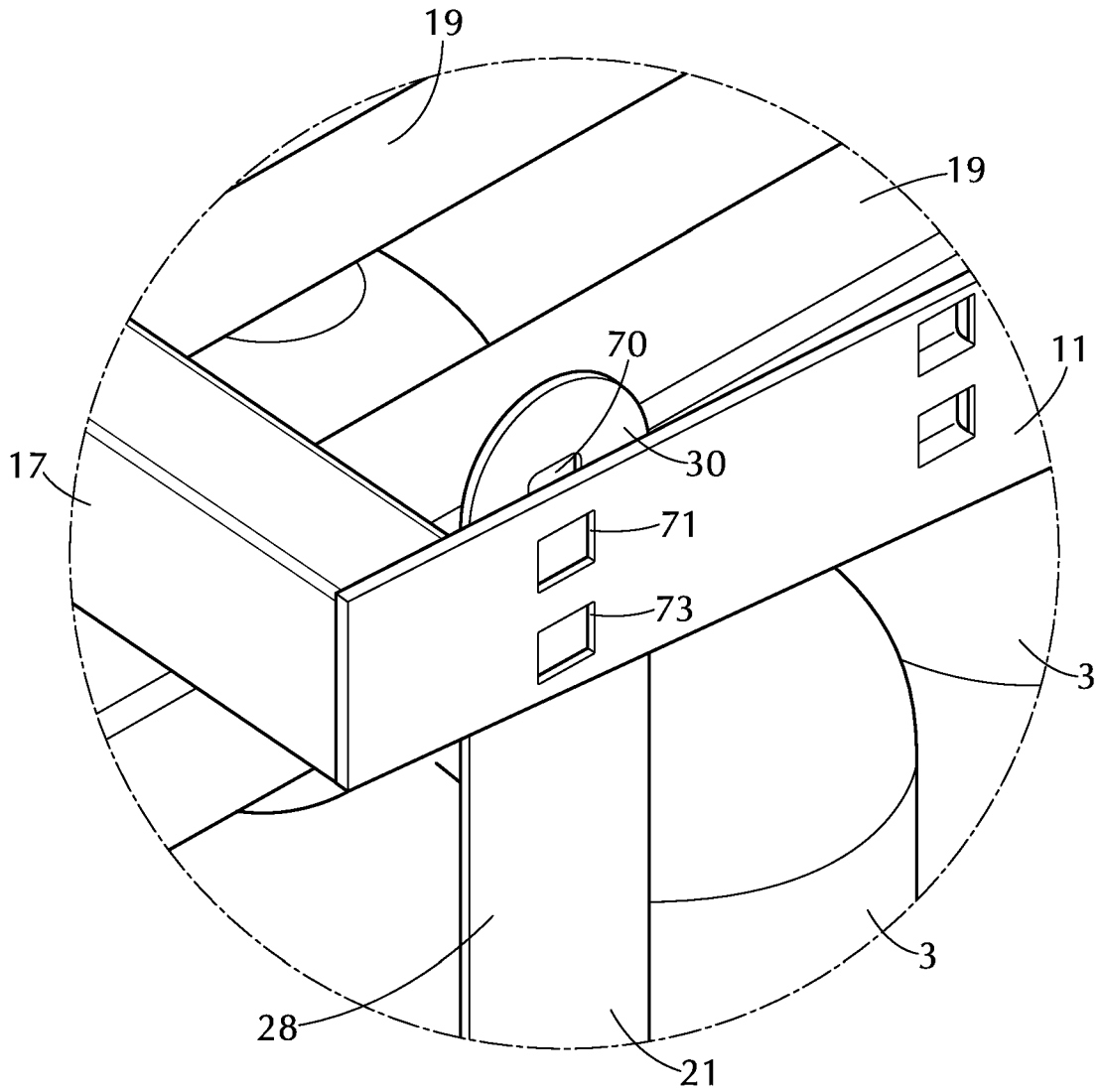
8/14



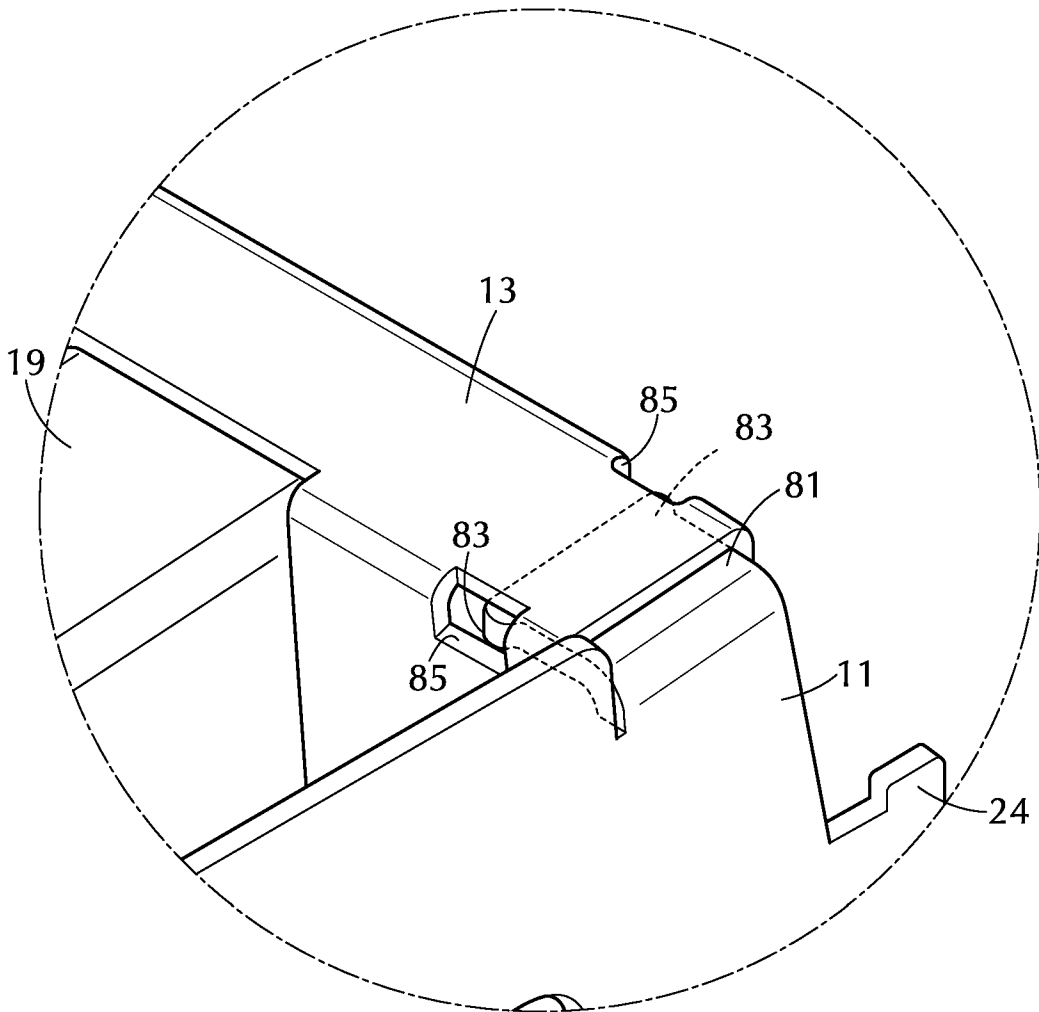
**FIG. 8**



**FIG. 9**



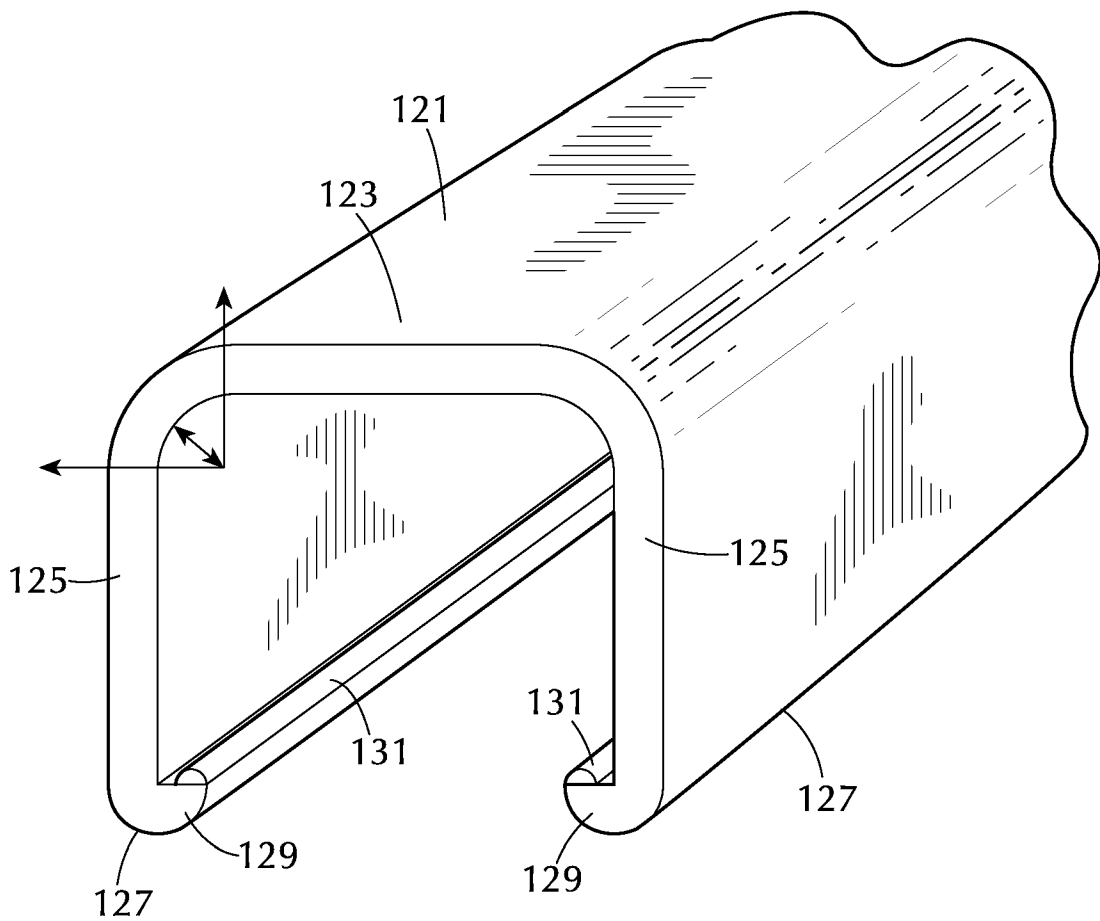
**FIG. 10**



**FIG. 11**

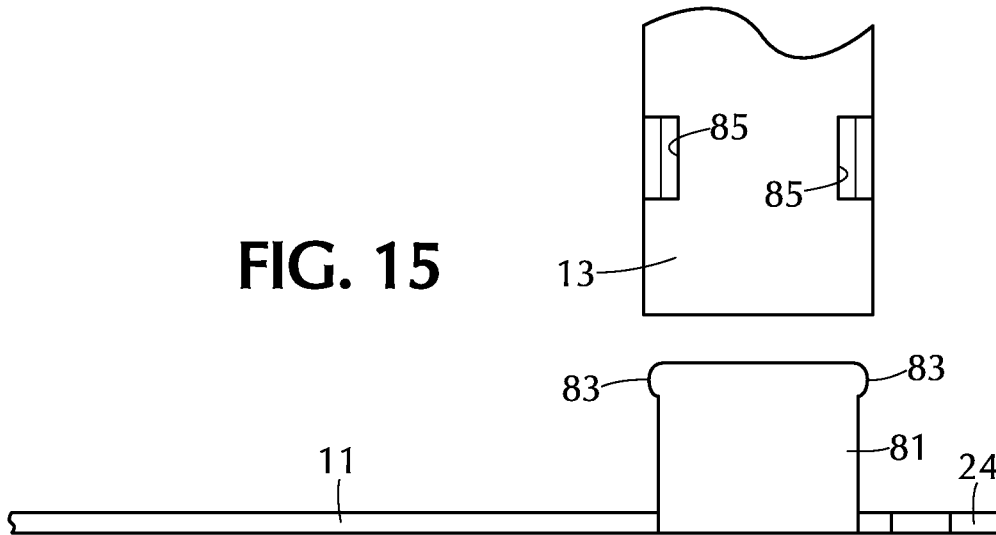




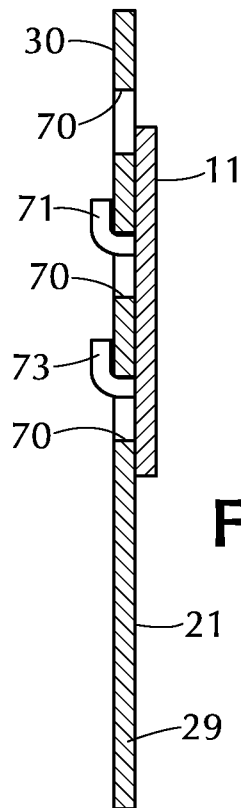


**FIG. 14**

**FIG. 15**



**FIG. 16**



## INTERNATIONAL SEARCH REPORT

International application No.

PCT/US 2012/050009

A. CLASSIFICATION OF SUBJECT MATTER		<i>A47F 7/28 (2006.01)</i> <i>A47F 1/04 (2006.01)</i>	
According to International Patent Classification (IPC) or to both national classification and IPC			
B. FIELDS SEARCHED			
Minimum documentation searched (classification system followed by classification symbols)			
A47F 7/00-7/28, 1/00-1/04, 5/00-5/12, A47B 73/00			
Documentation searched other than minimum documentation to the extent that such documents are included in the fields searched			
Electronic data base consulted during the international search (name of data base and, where practicable, search terms used)			
PatSearch (RUPTO internal), USPTO, PAJ, Esp@cenet			
C. DOCUMENTS CONSIDERED TO BE RELEVANT			
Category*	Citation of document, with indication, where appropriate, of the relevant passages	Relevant to claim No.	
Y	US 5586665 A ((ETALEX, INC.), 24.12.1996, abstract, col. 2, line 30 –col. 3, line 2, col. 3, lines 10-20, claims 1, 8	1-21	
Y	US 5595310 A (THE MEAD CORPORATION), 21.01.1997, col. 4, line 64 –col. 5, line 21, col. 5, lines 25-44, col. 5, line 67 –col. 6, line 13, col.6, lines 30-44, col. 7, lines 20-28, col. 7, lines 37-47, col. 8, lines 42-64, col. 9, lines 31-46, col. 10, lines 35-46, col. 11, lines 7-13, col. 11, line 61 –col.12, line 30, claims 27-29, fig. 14	1-21	
A	US 4344367 A (THE COCA-COLA COMPANY), 17.08.1982	1-21	
<input type="checkbox"/> Further documents are listed in the continuation of Box C.		<input type="checkbox"/> See patent family annex.	
* Special categories of cited documents:		“T” later document published after the international filing date or priority date and not in conflict with the application but cited to understand the principle or theory underlying the invention	
“A” document defining the general state of the art which is not considered to be of particular relevance		“X” document of particular relevance; the claimed invention cannot be considered novel or cannot be considered to involve an inventive step when the document is taken alone	
“E” earlier document but published on or after the international filing date		“Y” document of particular relevance; the claimed invention cannot be considered to involve an inventive step when the document is combined with one or more other such documents, such combination being obvious to a person skilled in the art	
“L” document which may throw doubts on priority claim(s) or which is cited to establish the publication date of another citation or other special reason (as specified)		“&” document member of the same patent family	
“O” document referring to an oral disclosure, use, exhibition or other means			
“P” document published prior to the international filing date but later than the priority date claimed			
Date of the actual completion of the international search		Date of mailing of the international search report	
28 September 2012 (28.09.2012)		25 October 2012 (25.10.2012)	
Name and mailing address of the ISA/ FIPS Russia, 123995, Moscow, G-59, GSP-5, Berezhkovskaya nab., 30-1		Authorized officer  R. Lopatkina	
Facsimile No. +7 (499) 243-33-37		Telephone No. 499-240-25-91	