



(11) **EP 3 141 857 B1**

(12) **EUROPEAN PATENT SPECIFICATION**

(45) Date of publication and mention of the grant of the patent:  
**26.09.2018 Bulletin 2018/39**

(51) Int Cl.:  
**F28D 1/047<sup>(2006.01)</sup> F28D 1/053<sup>(2006.01)</sup>**

(21) Application number: **16183460.1**

(22) Date of filing: **09.08.2016**

---

(54) **RADIATOR AND SUPERCRITICAL PRESSURE REFRIGERATION CYCLE USING THE SAME**  
**HEIZKÖRPER UND KÄLTEKREISLAUF MIT ÜBERKRITISCHEM DRUCK**  
**RADIATEUR ET CYCLE FRIGORIFIQUE À PRESSION SUPERCRITIQUE L'UTILISANT**

---

(84) Designated Contracting States:  
**AL AT BE BG CH CY CZ DE DK EE ES FI FR GB GR HR HU IE IS IT LI LT LU LV MC MK MT NL NO PL PT RO RS SE SI SK SM TR**

(30) Priority: **13.08.2015 JP 2015159916**

(43) Date of publication of application:  
**15.03.2017 Bulletin 2017/11**

(73) Proprietor: **MITSUBISHI HEAVY INDUSTRIES THERMAL SYSTEMS, LTD.**  
**Tokyo 108-8215 (JP)**

(72) Inventors:  
• **TAKEDA, Takeshi**  
**MINATO-KU, TOKYO, 108-8215 (JP)**

- **MURAKAMI, Kenichi**  
**MINATO-KU, TOKYO, 108-8215 (JP)**
- **OMURA, Minemasa**  
**MINATO-KU, TOKYO, 108-8215 (JP)**
- **SATO, Hitonobu**  
**NAGOYA-SHI, AICHI, 453-0862 (JP)**

(74) Representative: **Intès, Didier Gérard André et al**  
**Cabinet Beau de Loménie**  
**158 rue de l'Université**  
**75340 Paris Cedex 07 (FR)**

(56) References cited:  
**WO-A1-2004/061147 WO-A1-2007/083680**  
**WO-A1-2008/062771 DE-A1- 10 322 165**  
**JP-A- 2005 214 525**

**EP 3 141 857 B1**

---

Note: Within nine months of the publication of the mention of the grant of the European patent in the European Patent Bulletin, any person may give notice to the European Patent Office of opposition to that patent, in accordance with the Implementing Regulations. Notice of opposition shall not be deemed to have been filed until the opposition fee has been paid. (Art. 99(1) European Patent Convention).

---

## Description

### BACKGROUND OF THE INVENTION

#### 1. FIELD OF THE INVENTION

**[0001]** The present invention relates to a radiator for radiating heat of a refrigerant that is pressurized to supercritical pressure and for cooling the refrigerant, and a supercritical pressure refrigeration cycle using the radiator.

**[0002]** A radiator for radiating heat of a refrigerant that is pressurized to supercritical pressure where the flow passages of successive passes is gradually reduced from 8 to 4 is known from figure 4 of DE 103 22 165 A1.

#### 2. DESCRIPTION OF RELATED ART

**[0003]** A supercritical pressure refrigeration cycle using CO<sub>2</sub> (carbon dioxide) as a refrigerant includes a compressor that pressurizes the CO<sub>2</sub> refrigerant to supercritical pressure, and a radiator (gas cooler) that radiates heat of the CO<sub>2</sub> refrigerant discharged from the compressor, and cools the CO<sub>2</sub> refrigerant (refer to Japanese Unexamined Patent Application, Publication No. 2007-232365, for example). As a radiator applied to this type of supercritical pressure refrigeration cycle, a fin and tube type heat exchanger including a large number of plate fins disposed at predetermined intervals, and a plurality of heat transfer pipes that are inserted into the plate fins, and allow a refrigerant to flow therein is generally used, and high efficiency of heat exchange with outside air is attained.

**[0004]** Furthermore, as such a fin and tube type heat exchanger, a heat exchanger that includes a plurality of refrigerant flow passages formed in parallel, and that attains improvement of cooling or heating capacity is known (refer to Japanese Unexamined Patent Application, Publication Nos. Hei07-208822 and Hei08-121915, for example).

#### BRIEF SUMMARY OF THE INVENTION

**[0005]** As described above, in the supercritical pressure refrigeration cycle configured such that a refrigerant is pressurized to supercritical pressure, even when the refrigerant is cooled by a radiator, the refrigerant is not condensed, and circulates in the radiator as a gas refrigerant in the supercritical pressure state with sensible heat change. In order to improve a coefficient of performance (COP) of the refrigeration cycle having such a configuration, it is desirable to enhance the heat exchanging performance of the radiator, and to further reduce the refrigerant temperature at each refrigerant flow passage outlet.

**[0006]** However, in the configuration of the conventional radiator, an outlet heat transfer pipe of one of refrigerant flow passages, and an inlet heat transfer pipes of the

one of the refrigerant flow passages and other refrigerant flow passages are disposed adjacent to each other, and therefore there is a fear that the outlet temperature of the refrigerant is increased by the high-temperature refrigerants flowing through the inlet heat transfer pipes.

**[0007]** The present invention has been made in view of the above circumstances, and an object of the invention is to provide a radiator capable of enhancing heat exchanging performance, and further reducing the refrigerant temperature at a refrigerant flow passage outlet, and a supercritical pressure refrigeration cycle using the same.

**[0008]** In order to solve the above problem, the radiator, and the supercritical pressure refrigeration cycle using the same of the present invention employ the following solutions.

**[0009]** That is, a radiator according to the present invention is a radiator for radiating heat of a refrigerant that is pressurized to supercritical pressure, the radiator including: multiple plate fins extending in a vertical direction and disposed at a predetermined pitch; and a plurality of refrigerant flow passages formed in parallel by multiple heat transfer pipe group inserted into the plate fins in multiple stages, wherein the plurality of refrigerant flow passages each include an inlet heat transfer pipe provided in upper parts of the plate fins, an outlet heat transfer pipe provided in lower parts of the plate fins, and an intermediate heat transfer pipe provided between the inlet heat transfer pipe and the outlet heat transfer pipe, and a flow passage cross sectional area of the refrigerant flow passages is gradually reduced from the inlet heat transfer pipes to the outlet heat transfer pipes.

**[0010]** According to the present invention, in the plurality of refrigerant flow passages, the inlet heat transfer pipes are provided in the upper parts of the plate fins, and the outlet heat transfer pipes are provided in the lower parts of the plate fins, and therefore the outlet heat transfer pipe of one of the refrigerant flow passages can be disposed to separate from the inlet heat transfer pipes of the one of the refrigerant flow passages and other refrigerant flow passages. Additionally, the intermediate heat transfer pipes are provided between the inlet heat transfer pipes and the outlet heat transfer pipes, and therefore the inlet heat transfer pipes and the outlet heat transfer pipes are not adjacent to each other. Furthermore, the flow passage cross sectional area of the refrigerant flow passages is gradually reduced from the inlet heat transfer pipes to the outlet heat transfer pipes, and therefore even when the cooling proceeds, and the gas density (specific gravity) of the refrigerants is increased, reduction in the flow velocity of the refrigerants is prevented, and heat exchange efficiency can be maintained. Accordingly, the refrigerant outlet temperatures are never increased by the high temperature refrigerants that flow through the inlet heat transfer pipes, and the refrigerant temperature at a radiator outlet can be further reduced by performance improvement of the radiator, and it is possible to improve the coefficient of perform-

ance (COP) of the refrigeration cycle.

**[0011]** Furthermore, according to the radiator of the present invention, in the above radiator, the flow passage cross sectional area of the refrigerant flow passages is reduced by gradual reduction in the number of circuits of the inlet heat transfer pipes, the intermediate heat transfer pipes and the outlet heat transfer pipes.

**[0012]** According to the present invention, the flow passage cross sectional area of the refrigerant flow passages is reduced by the gradual reduction in the number of circuits of the inlet heat transfer pipes, the intermediate heat transfer pipes, and the outlet heat transfer pipes, and therefore even when the cooling proceeds while the refrigerants entering from the inlet heat transfer pipes circulate in the intermediate heat transfer pipes and the outlet heat transfer pipes, and the gas density (specific gravity) of the refrigerants is increased, the flow passage cross sectional area of the refrigerant flow passages is gradually reduced in the refrigerant flow direction, so that reduction in the flow velocity of the refrigerants is prevented, and heat exchange efficiency can be maintained. Accordingly, high heat exchanging performance of the radiator is enhanced, and the refrigerant outlet temperature is further lowered, so that it is possible to improve the coefficient of performance of the refrigeration cycle.

**[0013]** Furthermore, according to the radiator of the present invention, in the above radiator, the flow passage cross sectional area of the refrigerant flow passages is reduced by gradual reduction in flow passage diameters of the inlet heat transfer pipes, the intermediate heat transfer pipes, and the outlet heat transfer pipes.

**[0014]** According to the present invention, the flow passage cross sectional area of the refrigerant flow passages is reduced by the gradual reduction in the flow passage diameters of the inlet heat transfer pipes, the intermediate heat transfer pipes, and the outlet heat transfer pipes, and therefore even when the cooling proceeds while the refrigerants entering from the inlet heat transfer pipes circulate in the intermediate heat transfer pipes and the outlet heat transfer pipes sequentially, and the gas density (specific gravity) of the refrigerants is increased, the flow passage cross sectional area of the refrigerant flow passages is gradually reduced in the refrigerant flow direction, so that reduction in the flow velocity of the refrigerants is prevented, and heat exchange efficiency can be maintained. Accordingly, high heat exchanging performance of the radiator is enhanced, and the refrigerant outlet temperature is further reduced, so that it is possible to improve the coefficient of performance of the refrigeration cycle.

**[0015]** Furthermore, according to the radiator of the present invention, in any of the above radiators, each of the refrigerant flow passages is formed such that the refrigerant circulates from the inlet heat transfer pipe of an upper stage to the outlet heat transfer pipe of a lower stage.

**[0016]** According to the present invention, each refrigerant flow passages is formed such that the refrigerant

circulates from the inlet heat transfer pipe of the upper stage to the outlet heat transfer pipe of the lower stage. Accordingly, the refrigerant that is pressurized to the supercritical pressure is cooled but is not condensed in the radiator, and the gas density (specific gravity) is increased, but each refrigerant flow passages is formed so as to allow the refrigerant to flow from the heat transfer pipe of the upper stage to the heat transfer pipe of the lower stage, so that it is possible to facilitate the circulation of the refrigerants in the radiator by gravity. Consequently, it is possible to improve heat exchange efficiency of the radiator, and further lower the refrigerant outlet temperature.

**[0017]** Furthermore, in any of the above radiators, the radiator of the present invention further includes a plurality of heat exchange parts divided up and down, wherein each of the refrigerant flow passages is formed such that the refrigerant flows from the upper heat exchange part to the lower heat exchange part.

**[0018]** According to the present invention, the radiator includes the plurality of heat exchange parts divided up and down, the refrigerant flow passages are each formed such that the refrigerant flows from the upper heat exchange part toward the lower heat exchange part, and therefore it is possible to form the temperature gradient of gradually lowering from the upper heat exchange part toward the lower heat exchange part. Consequently, it is possible to suppress temperature irregularity in the radiator to improve heat exchange efficiency, and further lower the refrigerant outlet temperature.

**[0019]** Furthermore, according to the radiator of the present invention, in any of the above radiators, each of the refrigerant flow passages includes a first intermediate heat transfer pipe continued to the inlet heat transfer pipe, and a second intermediate heat transfer pipe or a third intermediate heat transfer pipe continued to the outlet heat transfer pipe, and includes an intermediate header connected to all the first intermediate heat transfer pipes, the second intermediate heat transfer pipes or the third intermediate heat transfer pipes of the refrigerant flow passages.

**[0020]** According to the present invention, each of the refrigerant flow passages includes the first intermediate heat transfer pipe continued to the inlet heat transfer pipe, and the second intermediate heat transfer pipe or the third intermediate heat transfer pipe continued to the outlet heat transfer pipe, and includes the intermediate header connected to all the first intermediate heat transfer pipes, the second intermediate heat transfer pipes or the third intermediate heat transfer pipes of the refrigerant flow passages, and therefore even in a case where distribution of the refrigerants in the inlet heat transfer pipes of the refrigerant flow passages is inappropriate, the refrigerants are collected in the intermediate header once, and thereafter distributed in the refrigerant flow passages again, and therefore the distribution can be made appropriate. Consequently, the distribution of the refrigerants into the respective refrigerant flow passages

is made appropriate, and heat exchanging performance of the radiator is improved, and it is possible to further lower the refrigerant outlet temperature.

**[0021]** Furthermore, according to the radiator of the present invention, in any of the above radiators, the heat transfer pipe group is inserted into the plate fins in multiple rows and stages, and the inlet heat transfer pipes are disposed in a row on a leeward side with respect to the outlet heat transfer pipes.

**[0022]** According to the present invention, the heat transfer pipe group is inserted into the plate fins in the multiple rows and stages, and the inlet heat transfer pipes are disposed in the row on the leeward side with respect to the outlet heat transfer pipes, and therefore the refrigerants flowing through the outlet heat transfer pipes can be prevented from being heated by air whose temperature is increased due to heat exchange with the high temperature refrigerants flowing through the inlet heat transfer pipes, and increase in the refrigerant outlet temperature can be suppressed. Accordingly, it is possible to further lower the refrigerant outlet temperature of the radiator, and improve the coefficient of performance of the refrigeration cycle.

**[0023]** Furthermore, a supercritical pressure refrigeration cycle according to the present invention includes: any of the above radiators; and a closed-cycle refrigerant circuit connecting a compressor for pressurizing a refrigerant to supercritical pressure, a decompression device, and a load side heat exchanger by piping.

**[0024]** According to the present invention, the supercritical pressure refrigeration cycle includes: any of the above radiators; and the closed-cycle refrigerant circuit connecting the compressor for pressurizing the refrigerant to supercritical pressure, the decompression device, and the load side heat exchanger by piping, and therefore the high-performance radiator having improved heat exchange efficiency and heat exchanging performance is incorporated, so that it is possible to enhance the cooling effect of the refrigerant, and further lower the refrigerant temperature at a radiator outlet. Accordingly, it is possible to provide the supercritical pressure refrigeration cycle having a further enhanced coefficient of performance (COP).

**[0025]** According to the radiator of the present invention, the outlet heat transfer pipe of one of the refrigerant flow passages can be disposed to separate from the inlet heat transfer pipes of the one of the refrigerant flow passages and other refrigerant flow passages. Additionally, the inlet heat transfer pipes are not adjacent to the outlet heat transfer pipes, and even when the cooling proceeds, and the gas density (specific gravity) of the refrigerants is increased, reduction in the flow velocity of the refrigerants is prevented, and heat exchange efficiency can be maintained. Accordingly, the refrigerant outlet temperature is never increased by the high temperature refrigerants that flow through the inlet heat transfer pipes, and can further reduce the refrigerant temperature at a radiator outlet by performance improvement of the radiator,

and it is possible to improve the coefficient of performance (COP) of the refrigeration cycle.

**[0026]** According to the supercritical pressure refrigeration cycle of the present invention, the high-performance radiator having improved heat exchange efficiency and heat exchanging performance is incorporated, so that it is possible to enhance the cooling effect of the refrigerant, and further lower the refrigerant temperature at the radiator outlet. Accordingly, it is possible to provide the supercritical pressure refrigeration cycle having further enhanced coefficient of performance (COP).

## BRIEF DESCRIPTION OF THE DRAWINGS

**[0027]**

FIG. 1 is a configuration diagram of a supercritical pressure refrigeration cycle according to a first embodiment of the present invention;

FIG. 2 is a Mollier diagram of the supercritical pressure refrigeration cycle;

FIG. 3 is a schematic diagram of a radiator applied to the supercritical pressure refrigeration cycle;

FIG. 4 is a schematic diagram of another embodiment (1) of the radiator;

FIG. 5 is a schematic diagram of another embodiment (2) of the radiator;

FIG. 6 is a schematic diagram of another embodiment (3) of the radiator;

FIG. 7 is a schematic diagram of another embodiment (4) of the radiator; and

FIG. 8 is a schematic diagram of another embodiment (5) of the radiator.

## DESCRIPTION OF EMBODIMENTS

**[0028]** Hereinafter, embodiments according to the present invention will be described with reference to the drawings.

{FIRST EMBODIMENT}

**[0029]** Hereinafter, a first embodiment of the present invention will be described with reference to FIG. 1 to FIG. 3.

**[0030]** FIG. 1 is a configuration diagram of a supercritical pressure refrigeration cycle according to the first embodiment of the present invention, FIG. 2 is a Mollier diagram of the supercritical pressure refrigeration cycle, and FIG. 3 is a schematic diagram of a radiator applied to the cycle. The present invention is not limited to the following embodiments, and it goes without saying that components in the following embodiments include components that are replaceable and easy to replace by a person skilled in the art, or substantially the same components.

**[0031]** As illustrated in FIG. 1, a supercritical pressure refrigeration cycle 10 according to this embodiment in-

cludes a heat source unit 11 and a load unit 12. In the supercritical pressure refrigeration cycle 10, a liquid refrigerant pipe 13 and a gas refrigerant pipe 14 connect the heat source unit 11 and the load unit 12, so that a closed-cycle refrigerant circuit 15 is formed. This closed-cycle refrigerant circuit 15 is filled with a carbon dioxide refrigerant (hereinafter referred to as a CO<sub>2</sub> refrigerant) whose high pressure side becomes supercritical pressure. The CO<sub>2</sub> refrigerant is a refrigerant having an advantage of having a small load to environment, has no toxicity, has no combustibility, and is safe and cheap.

**[0032]** As the refrigerant, as long as the high pressure side becomes supercritical pressure, of course, other refrigerant may be used.

**[0033]** The heat source unit 11 includes a compressor 16 that compresses a refrigerant, and an oil separator 18, a radiator (gas cooler) 19, and an expansion valve (decompression device) 20 are sequentially connected on the discharge side of the compressor 16 through a refrigerant discharge pipe 17. A heat source unit side liquid refrigerant pipe 30 for allowing a liquefied refrigerant to circulate is connected on the outlet side of the expansion valve 20, and is connected to the liquid refrigerant pipe 13. Additionally, a heat source unit side refrigerant suction pipe 21 is connected on the suction side of the compressor 16, and is connected to the gas refrigerant pipe 14 through an accumulator (not illustrated) and the like.

**[0034]** The compressor 16 includes an electric motor and a compression element 23 in a sealed housing 22, the compression element 23 herein is a two-stage compressible compressor including a low stage compression element and a high stage compression element, and compresses low pressure refrigerant gas sucked through the refrigerant suction pipe 21 to discharge, to the refrigerant discharge pipe 17, high temperature and high pressure refrigerant gas that is pressurized to supercritical pressure. The compression element 23 is driven by the electric motor (not illustrated), and the rotational frequency of the compression element 23 is adjustable by change in the operation frequency of the electric motor. Additionally, inside the sealed housing 22, oil for lubricating respective parts (a bearing and a sliding part) of the compression element 23 is housed, and a sensor 29 that detects oil quantity in the sealed housing 22 is provided.

**[0035]** The oil separator 18 separates oil contained in the high pressure refrigerant gas (supercritical pressure) discharged from the compressor 16, from a refrigerant. This oil separator 18 includes an oil return pipe 24 that returns the separated oil to the sealed housing 22 of the compressor 16, and the oil return pipe 24 is connected to the refrigerant suction pipe 21 through a solenoid valve 25, and a capillary tube (throttle) 26. In this embodiment, the solenoid valve 25 opens/closes on the basis of a signal of the sensor 29 that detects oil quantity.

**[0036]** The gas cooler 19 heat-exchanges the high temperature and high pressure (supercritical pressure) refrigerant gas discharged from the compressor 16 with

outside air, and radiates heat to cool the high temperature and high pressure (supercritical pressure) refrigerant gas. As described later, the gas cooler 19 is composed of a fin and tube type heat exchanger, and is disposed so as to face a blower fan (not illustrated) that blows outside air to the heat exchanger.

**[0037]** The expansion valve 20 decompresses (expands) and liquefies the gas refrigerant cooled by the gas cooler 19.

**[0038]** On the other hand, the load unit 12 includes a load unit side pipe 27 connected to the liquid refrigerant pipe 13 and the gas refrigerant pipe 14, and a vaporizer (load side heat exchanger) 28 provided in this load unit side pipe 27, vaporizes a liquid refrigerant supplied through the liquid refrigerant pipe 13 by use of the vaporizer 28, and is used as an indoor unit for cooling that cools an object to be cooled such as air, or various cooling apparatuses for freezing/refrigerating. The vaporizer 28 is composed of a fin and tube type heat exchanger similarly to the gas cooler 19, and is provided with a blower fan (not illustrated) that blows air to be cooled to the heat exchanger.

**[0039]** The vaporizer 28 is used for cooling or freezing and refrigerating by absorbing heat from the air to be cooled, vaporizing the liquid refrigerant, and cooling the air. The low temperature and low pressure refrigerant gas vaporized by the vaporizer 28 passes through the gas refrigerant pipe 14, the accumulator, and the refrigerant suction pipe 21 to be sucked in the compressor 16, and is compressed again. While the single load unit 12 is connected in this embodiment, a plurality of the load units 12 having the vaporizers 28 may be connected in parallel. In this case, each of the expansion valves 20 is desirably provided in the inlet side (liquid refrigerant pipe 13 side) of the vaporizer 28 in each load unit side pipe 27.

**[0040]** In the supercritical pressure refrigeration cycle 10, the refrigerant is pressurized to the supercritical pressure, and therefore even the refrigerant is cooled by the gas cooler 19, this refrigerant is not condensed, and passes through the gas cooler 19 as a gas refrigerant subjected to sensible heat change. FIG. 2 is a Mollier diagram of the supercritical pressure refrigeration cycle 10 of the refrigerant that is pressurized to the supercritical pressure. In FIG. 2, a point A shows the pressure and the enthalpy of the refrigerant on the suction side of the compressor 16. Similarly, a point B shows the pressure and the enthalpy of the refrigerant on the inlet side of the gas cooler 19, a point C shows the pressure and the enthalpy of the refrigerant on the outlet side of the gas cooler 19, and a point D shows the pressure and the enthalpy of the refrigerant on the inlet side of the vaporizer 28. Additionally, the broken lines in FIG. 2 illustrate respective isotherms.

**[0041]** As described above, in the gas cooler 19, the sensible heat change by cooling is performed. In this case, as illustrated in FIG. 2, when enthalpy quantity of 120°C to 100°C, enthalpy quantity of 100°C to 80°C, enthalpy quantity of 80°C to 60°C, and enthalpy quantity of

60°C to about 35°C are denoted by a, b, c, and d, respectively, the enthalpy quantities satisfy  $a < b < c < d$ , and the enthalpy quantity d of 60°C to about 35°C is particularly larger than the enthalpy quantities in other temperature ranges. Thus, the refrigerant outlet temperature in the gas cooler 19 is further reduced, so that a cooling effect can be increased by the lowered amount, and it is possible to improve a coefficient of performance (COP).

**[0042]** Hereinafter, a configuration of the gas cooler (radiator) 19 capable of further reducing the refrigerant outlet temperature will be described. FIG. 3 is a schematic diagram of the gas cooler 19 according to this embodiment.

**[0043]** As illustrated in FIG. 3, the gas cooler 19 includes a large number of strip-like plate fins 31 vertically extending and disposed in parallel to each other at predetermined intervals (pitches), and a heat transfer pipe group 33 composed of a plurality of heat transfer pipes penetrating a large number of these plate fins 31, and allows air to flow in the direction orthogonal to a paper surface.

**[0044]** The heat transfer pipe group 33 is disposed in one row multiple stages (12 stages in this embodiment) in the vertical direction of the plate fins 31. An in-radiator refrigerant flow passage is formed by the heat transfer pipe group 33 such that a plurality of branched refrigerant flow passages 34A, 34B, 34C (three in this embodiment) are formed in parallel on the inlet side, and the number of refrigerant flow passages (the number of circuits) is reduced to two refrigerant flow passages 34D, 34E from the above branched refrigerant flow passages 34A, 34B, 34C toward the outlet side, and a single refrigerant flow passage 34F is further formed on the outlet side.

**[0045]** Thus, the in-radiator refrigerant flow passage is formed so as to branch the refrigerant flow passage into the plurality of refrigerant flow passages 34A, 34B, 34C on the inlet side, and gradually reduce the number of the refrigerant flow passages from the inlet to the outlet, so that the refrigerant is distributed to flow through the respective refrigerant flow passages 34A, 34B, 34C, and therefore it is possible to reduce the flow rate of the refrigerant flowing through each of the refrigerant flow passages 34A, 34B, 34C, and it is possible to shorten a refrigerant flow passage length from the refrigerant flow passages 34A, 34B, 34C to the single refrigerant flow passage 34F on the outlet side. Consequently, it is possible to reduce the pressure loss of the refrigerants in the gas cooler 19 to improve the coefficient of performance.

**[0046]** The number of the refrigerant flow passages (the number of circuits) in the gas cooler 19 is gradually reduced from the inlet side to the outlet side, and the flow passage cross sectional area of the refrigerant flow passages is gradually reduced with the reduction in the number of the refrigerant flow passages, so that even when the cooling of the refrigerants in the gas cooler 19 proceeds, and the gas density (specific gravity) of the refrigerants is gradually increased with this cooling, reduction in the flow velocity of the refrigerants is prevented,

and heat exchange efficiency is maintained, so that it is possible to obtain high heat exchanging performance.

**[0047]** The gas cooler 19 includes an inlet header 36 connected to an inlet pipe 35 (refrigerant discharge pipe 17) through the oil separator 18, and an outlet side header 38, and forms the in-radiator refrigerant flow passage such that the three refrigerant flow passages 34A, 34B, 34C on the inlet side are first reduced to the two refrigerant flow passages 34D, 34E, and further reduced to the single refrigerant flow passage 34F on the outlet side between this inlet header 36 and the outlet side header 38, the number of the refrigerant flow passages (the number of circuits) is reduced in the pattern of  $3 \rightarrow 2 \rightarrow 1$ . This in-radiator refrigerant flow passage is formed by connecting four heat transfer pipes, has a configuration in which a refrigerant flows from the upper side to the lower side in the height direction (vertical direction) of the gas cooler 19, and has a configuration in which an outlet heat transfer pipe 42C of a lowermost stage is connected to an outlet pipe 37 (refrigerant discharge pipe 17) which leads to the expansion valve 20.

**[0048]** The refrigerant flow passages 34A, 34B, 34C on the inlet side include inlet heat transfer pipes 40A, 40B, 40C connected to the inlet header 36, respectively, and these inlet heat transfer pipes 40A, 40B, 40C are disposed in upper parts (the first stage, the third stage, the fifth stage) of the plate fins 31. Third intermediate heat transfer pipes 41A3, 41B3 are disposed on the outlet side, and connected to the outlet side header 38 that allows the plurality of refrigerant flow passages 34D, 34E to merge into the single refrigerant flow passage 34F, and outlet heat transfer pipes 42A1, 42A2 continued to the outlet pipe 37 (refrigerant discharge pipe 17) are disposed below the third intermediate heat transfer pipes 41A3, 41B3. These third intermediate heat transfer pipes 41A3, 41B3 and the outlet heat transfer pipes 42A1, 42A2 are disposed on lower parts of the plate fins 31 (the eighth stage, the tenth stage, the eleventh stage, and the twelfth stage).

**[0049]** The refrigerant flow passage 34A includes a first intermediate heat transfer pipe 41A1 connected to the inlet heat transfer pipe 40A through a U-shaped pipe 43. This refrigerant flow passage 34A is communicated with both the refrigerant flow passages 34D, 34E including second intermediate heat transfer pipes 41A2, 41B2 connected to the third intermediate heat transfer pipes 41A3, 41B3 respectively through U-shaped pipes 43, through an intermediate header 44. The first intermediate heat transfer pipe 41A1 is disposed below the inlet heat transfer pipe 40A by one stage, and the second intermediate heat transfer pipe 41A2 is disposed above the third intermediate heat transfer pipe 41A3 by one stage. The first intermediate heat transfer pipe 41A1 and the second intermediate heat transfer pipes 41A2 and 41B2 are communicated with each other through the intermediate header 44. Accordingly, the refrigerant flowing in the refrigerant flow passage 34A passes through the inlet heat transfer pipe 40A, and the first intermediate heat transfer

pipe 41A1 to flow through the second intermediate heat transfer pipe 41A2, the third intermediate heat transfer pipe 41A3 or the second intermediate heat transfer pipe 41B2, and the third intermediate heat transfer pipe 41B3 in order from the heat transfer pipe of the upper stage to the heat transfer pipe of the lower stage.

**[0050]** Similarly, the refrigerant flow passage 34B includes a first intermediate heat transfer pipe 41B1 connected to the inlet heat transfer pipe 40B through a U-shaped pipe 43. The refrigerant flow passage 34B is communicated with both the refrigerant flow passages 34D, 34E including the second intermediate heat transfer pipes 41A2, 41B2 connected to the third intermediate heat transfer pipes 41A3, 41B3 respectively through U-shaped pipes 43, through the intermediate header 44. The first intermediate heat transfer pipe 41B1 is disposed below the inlet heat transfer pipe 40B by one stage, and the second intermediate heat transfer pipe 41B2 is disposed above the third intermediate heat transfer pipe 41B3 by one stage. The first intermediate heat transfer pipe 41B1, and the second intermediate heat transfer pipes 41A2 and 41B2 are communicated with each other through the intermediate header 44. Accordingly, the refrigerant flowing in the refrigerant flow passage 34B passes through the inlet heat transfer pipe 40B, and the first intermediate heat transfer pipe 41B1 to flow through the second intermediate heat transfer pipe 41A2, the third intermediate heat transfer pipe 41A3 or the second intermediate heat transfer pipe 41B2, and the third intermediate heat transfer pipe 41B3 in order from the heat transfer pipe of the upper stage to the heat transfer pipe of the lower stage.

**[0051]** Furthermore, the refrigerant flow passage 34C includes a first intermediate heat transfer pipe 41C1 connected to the inlet heat transfer pipe 40C through a U-shaped pipe 43. This refrigerant flow passage 34C is communicated with both the refrigerant flow passages 34D, 34E including the second intermediate heat transfer pipes 41A2, 41B2 connected to the third intermediate heat transfer pipes 41A3, 41B3 respectively through U-shaped pipes 43, through the intermediate header 44. The first intermediate heat transfer pipe 41C1 is disposed below the inlet heat transfer pipe 40C by one stage. Additionally, the first intermediate heat transfer pipe 41C1, and the second intermediate heat transfer pipes 41A2 and 41B2 are communicated with each other through the intermediate header 44. Consequently, the refrigerant flowing in the refrigerant flow passage 34C passes through the inlet heat transfer pipe 40C, and the first intermediate heat transfer pipe 41C1 to flow through the second intermediate heat transfer pipe 41A2, the third intermediate heat transfer pipe 41A3 or the second intermediate heat transfer pipe 41B2, and the third intermediate heat transfer pipe 41B3 in order from the heat transfer pipe of the upper stage to the heat transfer pipe of the lower stage.

**[0052]** That is, the refrigerants distributed into the three refrigerant flow passages 34A, 34B, 34C to flow in the

gas cooler 19 flow in the two refrigerant flow passages 34D, 34E formed by the second intermediate heat transfer pipes 41A2, 41B2 and the third intermediate heat transfer pipes 41A3, 41B3, through the first intermediate heat transfer pipes 41A1, 41B1, 41C1 and the intermediate header 44. Additionally, during this circulation, the number of the refrigerant flow passages (the number of circuits) is reduced from 3 to 2, and the flow passage cross sectional area is reduced to two-thirds.

**[0053]** Furthermore, the outlet heat transfer pipe 42A1 is disposed below the third intermediate heat transfer pipe 41B3 by one stage, and is connected to the outlet side header 38, and the outlet heat transfer pipe 42A2 connected to the outlet pipe 37 (refrigerant discharge pipe 17) is disposed below this outlet heat transfer pipe 42A1 by one stage, and is connected to the outlet heat transfer pipe 42A1 through the U-shaped pipe 43. This outlet side header 38 allows the refrigerants that circulate in the two refrigerant flow passages 34D, 34E formed by the second intermediate heat transfer pipes 41A2, 41B2 and the third intermediate heat transfer pipes 41A3, 41B3 into merge and flow to the single refrigerant flow passage 34F formed by the outlet heat transfer pipes 42A1, 42A2. Herein, the number of the refrigerant flow passages (the number of circuits) is reduced from 2 to 1, and the flow passage cross sectional area is further reduced to one-half.

**[0054]** The gas cooler 19 includes an upper heat exchange part 45 and a lower heat exchange part 46 formed by division into a plurality of parts (two in this embodiment) in the height direction (vertical direction). Herein, the refrigerant flow passages 34A, 34B, 34C on the inlet side are formed on the upper heat exchange part 45 side. More specifically, the inlet heat transfer pipes 40A, 40B, 40C and the first intermediate heat transfer pipes 41A1, 41B1, 41C1 that form the refrigerant flow passages 34A, 34B, 34C, respectively are provided in the upper heat exchange part 45, the second intermediate heat transfer pipes 41A2, 41B2, the third intermediate heat transfer pipes 41A3, 41B3, and the outlet heat transfer pipes 42A1, 42A2 that form the refrigerant flow passages 34D, 34E and 34F on the downstream side respectively are connected to the inlet heat transfer pipes 40A, 40B, 40C and the first intermediate heat transfer pipes 41A1, 41B1, 41C1 through the intermediate header 44, respectively, and the lower heat exchange part 46 is provided.

**[0055]** Thus, according to this configuration, in the refrigerant flow passages 34A, 34B, 34C on the inlet side, the inlet heat transfer pipes 40A, 40B, 40C and the first intermediate heat transfer pipes 41A1, 41B1, 41C1 are disposed in the respective upper parts of the plate fins 31, and the outlet heat transfer pipes 42A1, 42A2 that form the single refrigerant flow passage 34F on the downstream side are disposed in the respective lower parts of the plate fins 31, and therefore the outlet heat transfer pipes 42A1, 42A2 that form the refrigerant flow passage 34F can be disposed to separate from the inlet heat transfer pipes 40A, 40B, 40C forming its own and other refrig-

erant flow passages.

**[0056]** Furthermore, in the refrigerant flow passages 34A, 34B, 34C on the inlet side, the first intermediate heat transfer pipes (intermediate heat transfer pipes) 41A1, 41B1, 41C1, the second intermediate heat transfer pipes (intermediate heat transfer pipes) 41A2, 41B2, and the third intermediate heat transfer pipes (intermediate heat transfer pipes) 41A3, 41B3 are disposed between the inlet heat transfer pipes 40A, 40B, 40C, and the outlet heat transfer pipes 42A1, 42A2, respectively, and therefore the inlet heat transfer pipes 40A, 40B, 40C, and the outlet heat transfer pipes 42A1, 42A2 are not adjacent to each other.

**[0057]** Accordingly, it is possible to suppress the temperature increase of the refrigerants that flow through the outlet heat transfer pipes 42A1, 42A2 by the high temperature (e.g., 100°C to 120°C) refrigerants that flow through the inlet heat transfer pipes 40A, 40B, 40C, and therefore it is possible to improve the coefficient of performance (COP) of the refrigeration cycle.

**[0058]** In the refrigerant flow passages 34A, 34B, 34C, 34D, 34E, 34F inside the gas cooler 19, the refrigerants circulate in the inlet heat transfer pipes 40A, 40B, 40C, the first intermediate heat transfer pipes 41A1, 41B1, 41C1, the second intermediate heat transfer pipes 41A2, 41B2, the third intermediate heat transfer pipes 41A3, 41B3, and the outlet heat transfer pipes 42A1, 42A2 in order from the heat transfer pipes of the upper stage to the heat transfer pipes of the lower stage. During this circulation, the refrigerant that is pressurized to the supercritical pressure is not condensed in the gas cooler 19, but the density (specific gravity) of refrigerant gas is increased with the cooling. Therefore, the in-radiator refrigerant flow passage is formed such that the refrigerants flow from the heat transfer pipes of the upper stage to the heat transfer pipes of the lower stage, so that it is possible to facilitate the circulation of the refrigerants by gravity to improve heat exchange efficiency.

**[0059]** In the above in-radiator refrigerant flow passage, the refrigerants are gradually cooled from the heat transfer pipes of the upper stage to the heat transfer pipes of the lower stage, and therefore a temperature difference between the refrigerants flowing through the adjacent heat transfer pipes can be made below a predetermined temperature, and heat transfer between the adjacent heat transfer pipes can be suppressed. When the Mollier diagram illustrated in FIG. 2 is referred, the outlet-inlet temperature difference of the gas cooler 19 is 85°C in this embodiment, and therefore the temperature difference between the refrigerants flowing through the adjacent heat transfer pipes can be lowered to about 20°C to 25°C. Additionally, the outlet-inlet temperature difference of the gas cooler 19 is generally about 60°C, and therefore, in this case, the temperature difference between the refrigerants flowing through the adjacent heat transfer pipes can be lowered to about 15°C.

**[0060]** Furthermore, the gas cooler 19 includes the upper heat exchange part 45 and the lower heat exchange

part 46 divided up and down, and the refrigerant flow passages 34A, 34B, 34C, 34D, 34E, 34F forming the in-radiator refrigerant flow passage each has a configuration in which the refrigerant sequentially flows from the upper heat exchange part 45 toward the lower heat exchange part 46, and therefore a temperature gradient of lowering a temperature from the upper heat exchange part 45 toward the lower heat exchange part 46 is formed. Therefore, it is possible to suppress temperature irregularity of the gas cooler 19.

**[0061]** The refrigerant flow passages 34A, 34B, 34C, 34D, 34E, 34F include the first intermediate heat transfer pipes 41A1, 41B1, 41C1 continued to the inlet heat transfer pipes 40A, 40B, 40C, and the second intermediate heat transfer pipes 41A2, 41B2 and the third intermediate heat transfer pipes 41A3, 41B3 continued to outlet heat transfer pipes 42A1, 42A2, and include the intermediate header 44 connected to all the first intermediate heat transfer pipes 41A1, 41B1, 41C1, the second intermediate heat transfer pipes 41A2, 41B2, and the third intermediate heat transfer pipes 41A3, 41B3, and therefore even when distribution of the refrigerants in the inlet heat transfer pipes 40A, 40B, 40C of the refrigerant flow passages 34A, 34B, 34C on the inlet side is inappropriate, the refrigerants are collected in the intermediate header 44 once, and thereafter distributed again when flowing through the refrigerant flow passages 34D, 34E, and therefore the distribution can be made appropriate. Consequently, it is possible to uniformize refrigerant distribution in the gas cooler 19 and sufficiently perform heat exchange.

**[0062]** Furthermore, in this embodiment, the flow passage cross sectional area of the refrigerant flow passages in the gas cooler 19 is gradually reduced from the inlet side to the outlet side. That is, the number of the refrigerant flow passages of the refrigerant flow passages 34A, 34B, 34C on the inlet side, and the number of refrigerant flow passages (the number of circuits) of the refrigerant flow passages 34D, 34E and the refrigerant flow passage 34F continued to the downstream side of the refrigerant flow passages 34A, 34B, 34C is gradually reduced in a manner of 3 → 2 → 1, and the flow passage cross sectional area of the in-radiator refrigerant flow passage is gradually reduced from the inlet side to the outlet side. Therefore, even when the cooling of the refrigerants in the gas cooler 19 proceeds, and the gas density (specific gravity) of the refrigerants is gradually increased with this cooling, reduction in the flow velocity of the refrigerants is prevented, and heat exchange efficiency is maintained, so that it is possible to obtain high heat exchanging performance, and it is possible to attain high performance of the gas cooler 19.

**[0063]** Now, other embodiments (1) to (5) of the present invention will be described with reference to FIG. 4 to FIG. 8.

{ANOTHER EMBODIMENT (1)}

**[0064]** FIG. 4 is a schematic diagram of a gas cooler according to another embodiment (1).

**[0065]** In this embodiment, the flow passage cross sectional area of refrigerant flow passages in a gas cooler 50 is not gradually reduced from the inlet side to the outlet side by gradual reduction in the number of the refrigerant flow passages (the number of circuits), and the flow passage cross sectional area of an in-radiator refrigerant flow passage is gradually reduced from the inlet side to the outlet side by change in flow passage diameters of heat transfer pipes of the refrigerant flow passages.

**[0066]** In this embodiment, a heat transfer pipe group 33 is disposed in one row multiple stages (12 stages in this embodiment) in the vertical direction of plate fins 31, and a plurality of refrigerant flow passages 34A, 34B, 34C (three in this embodiment) are formed in parallel by the heat transfer pipe group 33.

**[0067]** Thus, a plurality of the refrigerant flow passages 34A, 34B, 34C (the number of circuits: 3) are formed, so that the refrigerant is distributed into the refrigerant flow passages 34A, 34B, 34C to flow, and therefore it is possible to reduce the flow rate of the refrigerant flowing through each of the refrigerant flow passages 34A, 34B, 34C, and it is possible to shorten the respective refrigerant flow passage lengths of the refrigerant flow passages 34A, 34B, 34C. Consequently, it is possible to reduce the pressure loss of the refrigerants in the gas cooler 50 to improve a coefficient of performance.

**[0068]** The gas cooler 50 includes an inlet header 36 connected to an inlet pipe 35 (refrigerant discharge pipe 17) through an oil separator 18, and an outlet side header 38 connected to an outlet pipe 37 (refrigerant discharge pipe 17) which leads to an expansion valve 20, and the three refrigerant flow passages 34A, 34B, 34C are formed from the inlet to the outlet between the inlet header 36 and the outlet side header 38. These refrigerant flow passages 34A, 34B, 34C are each formed by connecting four heat transfer pipes, and allow the refrigerant to flow from the upper side to the lower side in the height direction (vertical direction) of the gas cooler 50.

**[0069]** The refrigerant flow passages 34A, 34B, 34C include inlet heat transfer pipes 40A, 40B, 40C connected to the inlet header 36, respectively. The inlet heat transfer pipes 40A, 40B, 40C are disposed in upper parts (the first stage, the third stage, the fifth stage) of the plate fins 31. Additionally, the refrigerant flow passages 34A, 34B, 34C include outlet heat transfer pipes 42A, 42B, 42C connected to the outlet side header 38, respectively. These outlet heat transfer pipes 42A, 42B, 42C are disposed in lower parts of the plate fins 31 (the eighth stage, the tenth stage, and the twelfth stage).

**[0070]** The refrigerant flow passage 34A includes a first intermediate heat transfer pipe 41A1 connected to the inlet heat transfer pipe 40A through a U-shaped pipe 43, and a second intermediate heat transfer pipe 41A2 connected to the outlet heat transfer pipe 42A through a U-

shaped pipe 43. The first intermediate heat transfer pipe 41A1 is disposed below the inlet heat transfer pipe 40A by one stage, and the second intermediate heat transfer pipe 41A2 is disposed above the outlet heat transfer pipe 42A by one stage. Additionally, the first intermediate heat transfer pipe 41A1 and the second intermediate heat transfer pipe 41A2 are communicated with each other through an intermediate header 44. Consequently, in the refrigerant flow passage 34A, the refrigerant flows through the inlet heat transfer pipe 40A, the first intermediate heat transfer pipe 41A1, the second intermediate heat transfer pipe 41A2, and the outlet heat transfer pipe 42A in order from the heat transfer pipe of the upper stage to the heat transfer pipe of the lower stage.

**[0071]** Similarly, the refrigerant flow passage 34B includes a first intermediate heat transfer pipe 41B1 connected to the inlet heat transfer pipe 40B through a U-shaped pipe 43, and a second intermediate heat transfer pipe 41B2 connected to the outlet heat transfer pipe 42B through a U-shaped pipe 43. The first intermediate heat transfer pipe 41B1 is disposed below the inlet heat transfer pipe 40B by one stage, and the second intermediate heat transfer pipe 41B2 is disposed above the outlet heat transfer pipe 42B by one stage. Additionally, the first intermediate heat transfer pipe 41B1 and the second intermediate heat transfer pipe 41B2 are communicated with each other through the intermediate header 44. Consequently, in the refrigerant flow passage 34B, the refrigerant flows through the inlet heat transfer pipe 40B, the first intermediate heat transfer pipe 41B1, the second intermediate heat transfer pipe 41B2, and the outlet heat transfer pipe 42B in order from the heat transfer pipe of the upper stage to the heat transfer pipe of the lower stage.

**[0072]** Furthermore, the refrigerant flow passage 34C includes a first intermediate heat transfer pipe 41C1 connected to the inlet heat transfer pipe 40C through a U-shaped pipe 43, and a second intermediate heat transfer pipe 41C2 connected to the outlet heat transfer pipe 42C through a U-shaped pipe 43. The first intermediate heat transfer pipe 41C1 is disposed below the inlet heat transfer pipe 40C by one stage, and the second intermediate heat transfer pipe 41C2 is disposed above the outlet heat transfer pipe 42C by one stage. Additionally, the first intermediate heat transfer pipe 41C1 and the second intermediate heat transfer pipe 41C2 are communicated with each other through the intermediate header 44. Consequently, in the refrigerant flow passage 34C, the refrigerant flows through the inlet heat transfer pipe 40C, the first intermediate heat transfer pipe 41C1, the second intermediate heat transfer pipe 41C2, and the outlet heat transfer pipe 42C in order from the heat transfer pipe of the upper stage to the heat transfer pipe of the lower stage.

**[0073]** Herein, the flow passage diameters of the four heat transfer pipes forming the flow passage of each of the refrigerant flow passages 34A, 34B, 34C, namely, the inlet heat transfer pipes 40A, 40B, 40C, the first in-

intermediate heat transfer pipes 41A1, 41B1, 41C1, the second intermediate heat transfer pipes 41A2, 41B2, 41C2, and the outlet heat transfer pipes 42A, 42B, 42C are flow passage diameters satisfying the relation of inlet heat transfer pipe > first intermediate heat transfer pipe > second intermediate heat transfer pipe > outlet heat transfer pipe. Consequently, the respective flow passage cross sectional areas of the refrigerant flow passages 34A, 34B, 34C are set so as to be gradually reduced from the inlet side to the outlet side. Herein, the flow passage diameter of each pipe expresses the inner diameter of a circular pipe, but means a fluid diameter that is a diameter conversion value of a pipe in a case of a pipe other than the circular pipe. The present invention includes a case where the pipe other than the circular pipe is used.

**[0074]** The gas cooler 50 includes an upper heat exchange part 45 and a lower heat exchange part 46 formed by division into a plurality of parts (two in this embodiment) in the height direction (vertical direction). The refrigerant flow passages 34A, 34B, 34C are each formed so as to sequentially circulate in the upper heat exchange part 45 and the lower heat exchange part 46. More specifically, in the refrigerant flow passage 34A, the inlet heat transfer pipe 40A and the first intermediate heat transfer pipe 41A1 are provided in the upper heat exchange part 45, and the second intermediate heat transfer pipe 41A2 and the outlet heat transfer pipe 42A are provided in the lower heat exchange part 46 through the intermediate header 44.

**[0075]** Similarly, in the refrigerant flow passage 34B, the inlet heat transfer pipe 40B and the first intermediate heat transfer pipe 41B1 are provided in the upper heat exchange part 45, and the second intermediate heat transfer pipe 41B2 and the outlet heat transfer pipe 42B are provided in the lower heat exchange part 46. Additionally, in the refrigerant flow passage 34C, the inlet heat transfer pipe 40C and the first intermediate heat transfer pipe 41C1 are provided in the upper heat exchange part 45, and the second intermediate heat transfer pipe 41C2 and the outlet heat transfer pipe 42C are provided in the lower heat exchange part 46.

**[0076]** Thus, in this embodiment, in the refrigerant flow passages 34A, 34B, 34C, the inlet heat transfer pipes 40A, 40B, 40C are provided in the respective upper parts of the plate fins 31, and the outlet heat transfer pipes 42A, 42B, 42C are provided in the respective lower parts of the plate fins 31, and therefore the outlet heat transfer pipes 42A, 42B, 42C of the refrigerant flow passages 34A, 34B, 34C can be disposed to separate from the inlet heat transfer pipes 40A, 40B, 40C of its own and other refrigerant flow passages 34A, 34B, 34C.

**[0077]** Furthermore, in the refrigerant flow passages 34A, 34B, 34C, the first intermediate heat transfer pipes (intermediate heat transfer pipes) 41A1, 41B1, 41C1, and the second intermediate heat transfer pipes (intermediate heat transfer pipes) 41A2, 41B2, 41C2 are provided between the inlet heat transfer pipes 40A, 40B, 40C, and the outlet heat transfer pipes 42A, 42B, 42C, respective-

ly, and therefore the inlet heat transfer pipes 40A, 40B, 40C, and the outlet heat transfer pipes 42A, 42B, 42C are not adjacent to each other. Accordingly, it is possible to suppress increase in the refrigerant outlet temperature by the high temperature (e.g., 100°C to 120°C) refrigerants that flow through the inlet heat transfer pipes 40A, 40B, 40C, and therefore it is possible to improve the co-efficient of performance of the refrigeration cycle.

**[0078]** In the refrigerant flow passages 34A, 34B, 34C, the refrigerants flow through the inlet heat transfer pipes 40A, 40B, 40C, the first intermediate heat transfer pipes 41A1, 41B1, 41C1, the second intermediate heat transfer pipes 41A2, 41B2, 41C2, the outlet heat transfer pipes 42A, 42B, 42C in order from the heat transfer pipes of the upper stage to the heat transfer pipes of the lower stage. In a supercritical pressure refrigeration cycle 10, a refrigerant that is pressurized to supercritical pressure by a compressor 16 is not condensed in the gas cooler 50, but the density (specific gravity) of refrigerant gas is increased with the cooling. Therefore, the refrigerant flow passages 34A, 34B, 34C are formed such that the refrigerants flow from the heat transfer pipes of the upper stage to the heat transfer pipes of the lower stage, so that it is possible to facilitate the circulation of the refrigerants by gravity to improve heat exchange efficiency.

**[0079]** In the refrigerant flow passages 34A, 34B, 34C, the refrigerants are gradually cooled from the heat transfer pipes of the upper stage to the heat transfer pipes of the lower stage, and therefore a temperature difference between the refrigerants flowing through the adjacent heat transfer pipes can be made below a predetermined temperature, and heat transfer between the adjacent heat transfer pipes can be suppressed. When the Mollier diagram illustrated in FIG. 2 is referred, a temperature difference between refrigerants in the outlet and the inlet of the gas cooler 50 is 85°C in this embodiment, and therefore the temperature difference between the refrigerants flowing through the adjacent heat transfer pipes can be lowered to about 20°C to 25°C. Additionally, the outlet-inlet temperature difference of the gas cooler 50 is generally about 60°C, and therefore, in this case, the temperature difference between the refrigerants flowing through the adjacent heat transfer pipes can be lowered to about 15°C.

**[0080]** Furthermore, the gas cooler 50 includes the upper heat exchange part 45 and the lower heat exchange part 46 divided up and down, and the refrigerant flow passages 34A, 34B, 34C each has a configuration in which the refrigerant sequentially flows from the upper heat exchange part 45 toward the lower heat exchange part 46, and therefore a temperature gradient of lowering a temperature from the upper heat exchange part 45 toward the lower heat exchange part 46 is formed, and it is possible to suppress temperature irregularity of the gas cooler 50.

**[0081]** The refrigerant flow passages 34A, 34B, 34C include the first intermediate heat transfer pipes 41A1, 41B1, 41C1 continued to the inlet heat transfer pipes

40A, 40B, 40C, the second intermediate heat transfer pipes 41A2, 41B2, 41C2 continued to the outlet heat transfer pipes 42A, 42B, 42C, respectively, and include the intermediate header 44 connected to all the first intermediate heat transfer pipes 41A1, 41B1, 41C1 and the second intermediate heat transfer pipes 41A2, 41B2, 41C2 of the refrigerant flow passages 34A, 34B, 34C, and therefore even when distribution of the refrigerants in the inlet heat transfer pipes 40A, 40B, 40C of the refrigerant flow passages 34A, 34B, 34C is inappropriate, the refrigerants are collected in the intermediate header 44 once, and thereafter distributed again in the refrigerant flow passages 34A, 34B, 34C, and therefore the distribution can be made appropriate. Consequently, it is possible to sufficiently perform heat exchange in the gas cooler 50.

**[0082]** The flow passage cross sectional area of the refrigerant flow passages in the gas cooler 50 is gradually reduced from the inlet side to the outlet side. That is, the respective flow passage diameters (inner diameters) of the inlet heat transfer pipes 40A, 40B, 40C, the first intermediate heat transfer pipes 41A1, 41B1, 41C1, the second intermediate heat transfer pipes 41A2, 41B2, 41C2, and the outlet heat transfer pipes 42A, 42B, 42C forming the refrigerant flow passages 34A, 34B, 34C are set such that the relation of inlet heat transfer pipe > first intermediate heat transfer pipe > second intermediate heat transfer pipe > outlet heat transfer pipe is satisfied, and the respective flow passage cross sectional areas of the refrigerant flow passages 34A, 34B, 34C are set so as to be gradually reduced from the inlet side to the outlet side. Therefore, even when the cooling of the refrigerants in the gas cooler 50 proceeds, and the gas density (specific gravity) of the refrigerants is gradually increased with this cooling, reduction in the flow velocity of the refrigerants is prevented, and heat exchange efficiency is maintained, so that it is possible to obtain high heat exchanging performance.

{ANOTHER EMBODIMENT (2)}

**[0083]** FIG. 5 is a schematic diagram of a gas cooler according to another embodiment (2).

**[0084]** In this gas cooler 50, configurations identical with the configuration of the above gas cooler 50 are denoted by the same reference numerals, and description thereof will be omitted. In the gas cooler 50 of this embodiment, in refrigerant flow passages 34A, 34B, 34C, first intermediate heat transfer pipes 41A1, 41B1, 41C1 and second intermediate heat transfer pipes 41A2, 41B2, 41C2 are connected to each other through connecting pipes 47A, 47B, 47C, respectively. In this configuration, the intermediate header 44 is unnecessary, and therefore it is possible to realize miniaturization of the gas cooler 50.

**[0085]** In this embodiment, it goes without saying that the respective flow passage diameters of inlet heat transfer pipes 40A, 40B, 40C, the first intermediate heat trans-

fer pipes 41A1, 41B1, 41C1, the second intermediate heat transfer pipes 41A2, 41B2, 42C2, and outlet heat transfer pipes 42A, 42B, 42C forming the refrigerant flow passages 34A, 34B, 34C, respectively satisfy the relation of inlet heat transfer pipe > first intermediate heat transfer pipe > second intermediate heat transfer pipe > outlet heat transfer pipe.

**[0086]** In the above another embodiments (1), (2), the refrigerant flow passages 34A, 34B, 34C each include two pipes, namely include the first intermediate heat transfer pipes 41A1, 41B1, 41C1 and the second intermediate heat transfer pipes 41A2, 41B2, 41C2, respectively, as intermediate heat transfer pipes. However, the number of intermediate heat transfer pipes may be appropriately changed in response to the refrigerant flow rate or the size of plate fins 31. At least one intermediate heat transfer pipe may be provided, and the refrigerant flow passage may have a minimum configuration of a flow of one round trip and a half by three pipes, namely, the inlet heat transfer pipe, the intermediate heat transfer pipe, and the outlet heat transfer pipe. In this configuration, the outlet of the refrigerant is located on an opposite side to the inlet of the refrigerant in the direction in which the heat transfer pipe extends.

**[0087]** Thus, in a case where the refrigerant flow passages 34A, 34B, 34C are formed by three paths, a refrigerant temperature difference in the outlet and the inlet of the gas cooler 50 is 85°C (refer to FIG. 2), and therefore a temperature difference between the refrigerants flowing through the adjacent heat transfer pipes can be lowered to about 25°C to 30°C. In this configuration, compared to a refrigerant flow passages formed by four heat transfer pipes (4 paths), the temperature difference between the refrigerants flowing through the adjacent heat transfer pipes is increased, and may become about 30°C. Additionally, the outlet-inlet temperature difference of the gas cooler 50 is generally about 60°C, and therefore, in this case, the temperature difference between the refrigerants flowing through the adjacent heat transfer pipes can be lowered to about 20°C.

**[0088]** In the above respective embodiments, the intervals (pitches) of the heat transfer pipes are the same. However, for example, the interval between the upper heat exchange part 45 and the lower heat exchange part 46, and the interval between the first intermediate heat transfer pipe 41C1 of the refrigerant flow passage 34C, and the second intermediate heat transfer pipe 41A2 of the refrigerant flow passage 34A may be wider by one pipe more. In this configuration, heat transfer between the upper heat exchange part 45 and the lower heat exchange part 46 is suppressed, and therefore it is possible to further suppress increase in the refrigerant outlet temperature.

{ANOTHER EMBODIMENT (3)}

**[0089]** FIG. 6 is a schematic diagram of a gas cooler according to another embodiment (3).

**[0090]** While the gas coolers 19, 50 each include the one row of heat transfer pipe group 33 in the above respective embodiments, this embodiment is different from the above embodiments in that a plurality of rows of heat transfer pipe group 33 are provided. Configurations identical with the configurations of the above gas coolers 19, 50 are denoted by the same reference numerals, and description thereof will be omitted.

**[0091]** As illustrated in FIG. 6, a gas cooler 60 of this embodiment includes the heat transfer pipe group 33 formed by multiple rows and stages (two rows and six stages in this embodiment) heat transfer pipes. In the heat transfer pipe group 33, the height positions of the heat transfer pipes of each row are different, and heat transfer pipes of a row on a leeward side are disposed slightly above heat transfer pipes of a row on a windward side. Additionally, the gas cooler 60 includes three refrigerant flow passages 34A, 34B, 34C on an inlet side, formed in parallel by the heat transfer pipe group 33, two refrigerant flow passages 34D, 34E sequentially connected to the refrigerant flow passages 34A, 34B, 34C, and a single refrigerant flow passage 34F.

**[0092]** The refrigerant flow passages 34A, 34B, 34C on the inlet side include inlet heat transfer pipes 40A, 40B, 40C connected to an inlet header 36, respectively. These inlet heat transfer pipes 40A, 40B, 40C are disposed in upper parts (the first stage, the second stage, the third stage) of the row on the leeward side of plate fins 31. Additionally, the refrigerant flow passage 34F on outlet side includes outlet heat transfer pipes 42A1, 42A2 connected to an outlet side header 38. These outlet heat transfer pipes 42A1, 42A2 are disposed in respective lowermost parts (the sixth stage) of the rows on the leeward side and the windward side of the plate fins 31.

**[0093]** The refrigerant flow passage 34A includes a first intermediate heat transfer pipe 41A1 connected to the inlet heat transfer pipe 40A through a U-shaped pipe (not illustrated). This refrigerant flow passage 34A is communicated with both the refrigerant flow passages 34D, 34E including second intermediate heat transfer pipes 41A2, 41B2 connected to third intermediate heat transfer pipes 41A3, 41B3 respectively through U-shaped pipes (not illustrated), through an intermediate header 44. The first intermediate heat transfer pipe 41A1 is disposed in an uppermost stage of an adjacent row of the inlet heat transfer pipe 40A (row on the windward side), and the second intermediate heat transfer pipe 41A2 is disposed in a lower part (the fourth stage) of an adjacent row of the third intermediate heat transfer pipe 41A3 (row on the leeward side). Additionally, the first intermediate heat transfer pipe 41A1 and the second intermediate heat transfer pipe 41A2 are connected to each other through the intermediate header 44. Consequently, a refrigerant flowing in the refrigerant flow passage 34A passes through the inlet heat transfer pipe 40A, and the first intermediate heat transfer pipe 41A1 to flow through the second intermediate heat transfer pipe 41A2, the third intermediate heat transfer pipe 41A3 or the second in-

termediate heat transfer pipe 41B2, and the third intermediate heat transfer pipe 41B3 in order from the heat transfer pipe of the upper stage to the heat transfer pipe of the lower stage.

**[0094]** Similarly, the refrigerant flow passage 34B includes a first intermediate heat transfer pipe 41B1 connected to the inlet heat transfer pipe 40B through a U-shaped pipe. The refrigerant flow passage 34B is communicated with both the refrigerant flow passages 34D, 34E including the second intermediate heat transfer pipes 41A2, 41B2 connected to the third intermediate heat transfer pipes 41A3, 41B3 through the U-shaped pipes, respectively through the intermediate header 44. The first intermediate heat transfer pipe 41B1 is disposed in an upper part (the second stage) of an adjacent row of the inlet heat transfer pipe 40B (row on the windward side), and the second intermediate heat transfer pipe 41B2 is disposed in a lower part (the fifth stage) of an adjacent row (row on the leeward side) of the third intermediate heat transfer pipe 41B3. Additionally, the first intermediate heat transfer pipe 41B1 and the second intermediate heat transfer pipes 41A2 and 41B2 are communicated with each other through the intermediate header 44. Consequently, a refrigerant flowing in the refrigerant flow passage 34B passes through the inlet heat transfer pipe 40B, and the first intermediate heat transfer pipe 41B1 to flow through the second intermediate heat transfer pipe 41A2, the third intermediate heat transfer pipe 41A3 or the second intermediate heat transfer pipe 41B2, and the third intermediate heat transfer pipe 41B3 in order from the heat transfer pipe of the upper stage to the heat transfer pipe of the lower stage.

**[0095]** Furthermore, the refrigerant flow passage 34C includes a first intermediate heat transfer pipe 41C1 connected to the inlet heat transfer pipe 40C through a U-shaped pipe. The refrigerant flow passage 34C is communicated with both the refrigerant flow passages 34D, 34E including the second intermediate heat transfer pipes 41A2, 41B2 connected to the third intermediate heat transfer pipes 41A3, 41B3 respectively through U-shaped pipes, through the intermediate header 44. The first intermediate heat transfer pipe 41C1 is disposed in an upper part (the third stage) of an adjacent row of the inlet heat transfer pipe 40C (row on the windward side). Consequently, a refrigerant flowing in the refrigerant flow passage 34C passes through the inlet heat transfer pipe 40C, and the first intermediate heat transfer pipe 41C1 to flow through the second intermediate heat transfer pipe 41A2, the third intermediate heat transfer pipe 41A3 or the second intermediate heat transfer pipe 41B2, and the third intermediate heat transfer pipe 41B3 in order from the heat transfer pipe of the upper stage to the heat transfer pipe of the lower stage.

**[0096]** That is, the refrigerants distributed into the three refrigerant flow passages 34A, 34B, 34C to flow in the gas cooler 60 flow in the two refrigerant flow passages 34D, 34E formed by the second intermediate heat transfer pipes 41A2, 41B2 and the third intermediate heat

transfer pipes 41A3, 41B3, through the first intermediate heat transfer pipes 41A1, 41B1, 41C1 and the intermediate header 44. During this circulation, the number of the refrigerant flow passages (the number of circuits) is reduced from 3 to 2, and the flow passage cross sectional area is reduced to two-thirds.

**[0097]** Furthermore, the outlet heat transfer pipe 42A1 is disposed in the lowermost part (the sixth stage) of the adjacent rows of the third intermediate heat transfer pipe 41B3 (row on the leeward side), and is connected to the outlet side header 38, and the outlet heat transfer pipe 42A2 connected to the outlet pipe 37 (refrigerant discharge pipe 17) is disposed at the position of the lowermost part (the sixth stage) of the adjacent rows of this outlet heat transfer pipe 42A1 (row on the windward side), and is connected to the outlet side header 38 through the U-shaped pipe 43. This outlet side header 38 allows the refrigerants that circulate in the two refrigerant flow passages 34D, 34E formed by the second intermediate heat transfer pipes 41A2, 41B2 and the third intermediate heat transfer pipes 41A3, 41B3 to merge and flow into the single refrigerant flow passage 34F formed by the outlet heat transfer pipes 42A1, 42A2. Herein, the number of the refrigerant flow passages (the number of circuits) is reduced from 2 to 1, and the flow passage cross sectional area is further reduced to one-half.

**[0098]** The gas cooler 60 includes an upper heat exchange part 45 and a lower heat exchange part 46 formed by division into two parts in the height direction (vertical direction). The three refrigerant flow passages 34A, 34B, 34C on the inlet side are provided in the upper heat exchange part 45, and both the two refrigerant flow passages 34D, 34E at intermediate parts, and the single refrigerant flow passage 34F on the outlet side are provided in the lower heat exchange part 46 through the intermediate header 44, so that the refrigerants sequentially circulate from the upper heat exchange part 45 to the lower heat exchange part 46.

**[0099]** In this embodiment, the heat transfer pipe group 33 is inserted into the plate fins 31 in two rows and six stages, the inlet heat transfer pipes 40A, 40B, 40C of the refrigerant flow passages 34A, 34B, 34C on the inlet side are disposed at separated positions above the third intermediate heat transfer pipes 41A3, 41B3 and the outlet heat transfer pipes 42A1, 42A2 on the refrigerant outlet side, and disposed on the row of the leeward side, and therefore it is possible to suppress the influence of heat of air which heat-exchanges with the high temperature refrigerants flowing through the inlet heat transfer pipes 40A, 40B, 40C, and suppress increase in the outlet temperatures of the refrigerants.

**[0100]** Also in this embodiment, the number of the refrigerant flow passages of the refrigerant flow passages 34A, 34B, 34C on the inlet side, and the number of refrigerant flow passages (the number of circuits) of the refrigerant flow passages 34D, 34E and the refrigerant flow passage 34F continued to the downstream side of the refrigerant flow passages 34A, 34B, 34C can be grad-

ually reduced in a manner of  $3 \rightarrow 2 \rightarrow 1$ , and the flow passage cross sectional area of an in-radiator refrigerant flow passage can be gradually reduced from the inlet side to the outlet side. Therefore, even when the cooling of the refrigerants in the gas cooler 60 proceeds, and the gas density (specific gravity) of the refrigerants is gradually increased with this cooling, reduction in the flow velocity of the refrigerants is prevented, and heat exchange efficiency is maintained, so that it is possible to obtain high heat exchanging performance, and it is possible to enhance performance of the gas cooler 60.

{OTHER EMBODIMENTS (4), (5)}

**[0101]** FIG. 7 and FIG. 8 are schematic diagrams of gas coolers according to other embodiments (4) and (5).

**[0102]** In these embodiments, the intermediate header 44 is omitted similarly to another embodiment (2) illustrated in FIG. 5, and a heat transfer pipe group 33 is disposed in multiple rows and stages (two rows and six stages in this embodiment) like another embodiment (3) illustrated in FIG. 6.

**[0103]** In gas coolers 65, 70, configurations identical with the configurations of the above gas coolers 19, 60 are denoted by the same reference numerals, and description thereof will be omitted. In the gas cooler 65, in refrigerant flow passages 34A, 34B, 34C, first intermediate heat transfer pipes 41A1, 41B1, 41C1 and second intermediate heat transfer pipes 41A2, 41B2, 41C2 are connected to each other through connecting pipes 51A, 51B, 51C, respectively, as illustrated in FIG. 7. In this configuration, the intermediate header 44 is unnecessary, and therefore it is possible to realize miniaturization of the gas cooler 65.

**[0104]** As long as the inlet heat transfer pipes 40A, 40B, 40C are not adjacent to the outlet heat transfer pipes 42A, 42B, 42C, and the refrigerant flow passages 34A, 34B, 34C are formed so as to allow respective refrigerants to flow from the heat transfer pipes of the upper stage to the heat transfer pipes of the lower stage, location configuration of the heat transfer pipes can be appropriately changed. For example, in the gas cooler 70, as illustrated in FIG. 8, not all the inlet heat transfer pipes 40A, 40B, 40C is not provided in a row on a leeward side, and the inlet heat transfer pipe 40B may be provided in an uppermost stage of a row on a windward side. Similarly, not all the outlet heat transfer pipes 42A, 42B, 42C needs to be provided in the row on the windward side, and the outlet heat transfer pipe 42B may be provided in a lowermost stage of the row on the leeward side.

**[0105]** In the gas cooler 70 according to this modification, similarly to the above gas cooler 65, first intermediate heat transfer pipes 41A1, 41B1, 41C1 and second intermediate heat transfer pipes 41A2, 41B2, 41C2 are connected to each other through connecting pipes 52A, 52B, 52C, respectively, without providing the intermediate header 44. Also in this configuration, the intermediate header 44 may be provided in place of the connecting

pipes 52A, 52B, 52C.

[0106] Furthermore, in the gas coolers 65, 70, it goes without saying that the respective flow passage diameters (inner diameters) of the inlet heat transfer pipes 40A, 40B, 40C, the first intermediate heat transfer pipes 41A1, 41B1, 41C1, the second intermediate heat transfer pipes 41A2, 41B2, 42C2, and the outlet heat transfer pipes 42A, 42B, 42C, respectively satisfy the relation of inlet heat transfer pipe > first intermediate heat transfer pipe > second intermediate heat transfer pipe > outlet heat transfer pipe such that the flow passage cross sectional area of the refrigerant flow passages 34A, 34B, 34C is gradually reduced from the refrigerant inlet side to the outlet side. Therefore, even when the cooling of the refrigerants in the gas coolers 65, 70 proceeds, and the gas density (specific gravity) of the refrigerants is gradually increased with this cooling, reduction in the flow velocity of the refrigerants is prevented, and heat exchange efficiency is maintained, so that it is possible to obtain high heat exchanging performance, similarly to the above embodiments.

[0107] In the above embodiments, the flow passage cross sectional area of the refrigerant flow passages 34A to 34F is gradually reduced from the inlet side to the outlet side, and therefore a plurality of examples, in which the number of circuits of the refrigerant flow passages is gradually reduced, and a plurality of examples, in which the flow passage diameters (inner diameters) of the heat transfer pipes are gradually reduced, are exemplified. However, it is of course that the flow passage diameters (inner diameters) of the heat transfer pipes may be gradually reduced at the same time when the number of circuits is gradually reduced.

REFERENCE SIGNS LIST

[0108]

- 10 Supercritical pressure refrigeration cycle
- 15 Refrigerant circuit
- 16 Compressor
- 19, 50, 60, 65, 70 Gas cooler (radiator)
- 20 Expansion valve (decompression device)
- 28 Vaporizer (load side heat exchanger)
- 31 Plate fin
- 33 Heat transfer pipe group
- 34A, 34B, 34C, 34D, 34E, 34F Refrigerant flow passage
- 36 Inlet header
- 38 Outlet side header
- 40A, 40B, 40C Inlet heat transfer pipe
- 41A1, 41B1, 41C1 First intermediate heat transfer pipe (intermediate heat transfer pipe)
- 41A2, 41B2, 41C2 Second intermediate heat transfer pipe (intermediate heat transfer pipe)
- 41A3, 41B3 Third intermediate heat transfer pipe (intermediate heat transfer pipe)
- 42A1, 42A2, 42A, 42B, 42C Outlet heat transfer pipe

- 44 Intermediate header
- 45 Upper heat exchange part (heat exchange part)
- 46 Lower heat exchange part (heat exchange part)

Claims

1. A radiator for radiating heat of a refrigerant that is pressurized to supercritical pressure, the radiator comprising:

Multiple plate fins (31) extending in a vertical direction and disposed at a predetermined pitch; and

a plurality of refrigerant flow passages (34A, 34B, 34C, 34D, 34E, 34F) formed in parallel by multiple heat transfer pipe groups (33) inserted into the plate fins (31) in multiple stages, wherein the plurality of refrigerant flow passages (34A, 34B, 34C, 34D, 34E, 34F) each include an inlet heat transfer pipe (40A, 40B, 40C) provided in upper parts of the plate fins (31), an outlet heat transfer pipe (42A1, 42A2, 42A, 42B, 42C) provided in lower parts of the plate fins (31), and an intermediate heat transfer pipe (41A1, 41B1, 41C1, 41A2, 41B2, 41C2, 41A3, 41B3) provided between the inlet heat transfer pipe (40A, 40B, 40C) and the outlet heat transfer pipe (42A1, 42A2, 42A, 42B, 42C), and

a flow passage cross sectional area of the refrigerant flow passages (34A, 34B, 34C, 34D, 34E, 34F) is gradually reduced from the inlet heat transfer pipes (40A, 40B, 40C) to the outlet heat transfer pipes (42A1, 42A2, 42A, 42B, 42C).

2. The radiator according to claim 1, wherein the flow passage cross sectional area of the refrigerant flow passages (34A, 34B, 34C, 34D, 34E, 34F) is reduced by gradual reduction in the number of circuits of the inlet heat transfer pipes (40A, 40B, 40C), the intermediate heat transfer pipes (41A1, 41B1, 41C1, 41A2, 41B2, 41C2, 41A3, 41B3) and the outlet heat transfer pipes (42A1, 42A2, 42A, 42B, 42C).

3. The radiator according to claim 1, wherein the flow passage cross sectional area of the refrigerant flow passages (34A, 34B, 34C, 34D, 34E, 34F) is reduced by gradual reduction in flow passage diameters of the inlet heat transfer pipes (40A, 40B, 40C), the intermediate heat transfer pipes (41A1, 41B1, 41C1, 41A2, 41B2, 41C2, 41A3, 41B3), and the outlet heat transfer pipes (42A1, 42A2, 42A, 42B, 42C).

4. The radiator according to any of claims 1 to 3, wherein

- each of the refrigerant flow passages (34A, 34B, 34C, 34D, 34E, 34F) is formed such that the refrigerant circulates from the inlet heat transfer pipe (40A, 40B, 40C) of an upper stage to the outlet heat transfer pipe of a lower stage (42A1, 42A2, 42A, 42B, 42C).
- 5
5. The radiator according to any of claims 1 to 4, further comprising a plurality of heat exchange parts (45, 46) divided up and down, wherein
- 10
- each of the refrigerant flow passages (34A, 34B, 34C, 34D, 34E, 34F) is formed such that the refrigerant flows from the upper heat exchange part (45) to the lower heat exchange part (46).
- 15
6. The radiator according to any of claims 1 to 5, wherein
- 20
- each of the refrigerant flow passages (34A, 34B, 34C, 34D, 34E, 34F) includes a first intermediate heat transfer pipe (41A1, 41B1, 41C1) continued to the inlet heat transfer pipe (40A, 40B, 40C), and a second intermediate heat transfer pipe (41A2, 41B2, 41C2) or a third intermediate heat transfer pipe (41A3, 41B3) continued to the outlet heat transfer pipe (42A1, 42A2, 42A, 42B, 42C), and includes an intermediate header (44) connected to all the first intermediate heat transfer pipes (41A1, 41B1, 41C1), the second intermediate heat transfer pipes (41A2, 41B2, 41C2) or the third intermediate heat transfer pipes (41A3, 41B3) of the refrigerant flow passages (34A, 34B, 34C, 34D, 34E, 34F).
- 25
- 30
7. The radiator according to any of claims 1 to 6, wherein
- 35
- the heat transfer pipe group (33) is inserted into the plate fins (31) in multiple rows and stages, and the inlet heat transfer pipes (40A, 40B, 40C) are disposed in a row on a leeward side with respect to the outlet heat transfer pipes (42A1, 42A2, 42A, 42B, 42C).
- 40
8. A supercritical pressure refrigeration cycle comprising:
- 45
- the radiator according to any of claims 1 to 7; and a closed-cycle refrigerant circuit (15) connecting a compressor (16) for pressurizing a refrigerant to supercritical pressure, a decompression device (20), and a load side heat exchanger by piping.
- 50
- Patentansprüche**
1. Radiator zum Abstrahlen von Wärme eines Kältemittels, das auf einen superkritischen Druck druckbeaufschlagt ist, wobei der Radiator umfasst:
- 55
- mehrere Plattenfinnen (31), die sich in einer vertikalen Richtung erstrecken und mit einem zuvor festgelegten Mittenabstand angeordnet sind, und
- mehrere Kältemittelströmungsdurchgänge (34A, 34B, 34C, 34D, 34E, 34F), die parallel durch mehrere Wärmeübertragungsrohrgruppen (33) gebildet werden, die in die Plattenfinnen (31) in mehreren Stufen eingesetzt sind, wobei
- die mehreren Kältemittelströmungsdurchgänge (34A, 34B, 34C, 34D, 34E, 34F) jeweils ein Einlasswärmeübertragungsrohr (40A, 40B, 40C), das in oberen Teilen der Plattenfinnen (31) angeordnet ist, ein Auslasswärmeübertragungsrohr (42A1, 42A2, 42A, 42B, 42C), das in unteren Teilen der Plattenfinnen (31) angeordnet ist, und ein Zwischenwärmeübertragungsrohr (41A1, 41B1, 41C1, 41A2, 41B2, 41C2, 41A3, 41B3) enthalten, das zwischen dem Einlasswärmeübertragungsrohr (40A, 40B, 40C) und dem Auslasswärmeübertragungsrohr (42A1, 42A2, 42A, 42B, 42C) angeordnet ist, und eine Strömungsdurchgangs-Querschnittsfläche der Kältemittelströmungsdurchgänge (34A, 34B, 34C, 34D, 34E, 34F) sich allmählich von den Einlasswärmeübertragungsrohren (40A, 40B, 40C) zu den Auslasswärmeübertragungsrohren (42A1, 42A2, 42A, 42B, 42C) verringert.
2. Radiator nach Anspruch 1, wobei die Strömungsdurchgangs-Querschnittsfläche der Kältemittelströmungsdurchgänge (34A, 34B, 34C, 34D, 34E, 34F) durch allmähliche Reduzierung der Anzahl der Kreisläufe der Einlasswärmeübertragungsrohre (40A, 40B, 40C), der Zwischenwärmeübertragungsrohre (41A1, 41B1, 41C1, 41A2, 41B2, 41C2, 41A3, 41B3) und der Auslasswärmeübertragungsrohre (42A1, 42A2, 42A, 42B, 42C) verringert wird.
3. Radiator nach Anspruch 1, wobei die Strömungsdurchgangs-Querschnittsfläche der Kältemittelströmungsdurchgänge (34A, 34B, 34C, 34D, 34E, 34F) durch allmähliche Reduzierung der Strömungsdurchgangsdurchmesser der Einlasswärmeübertragungsrohre (40A, 40B, 40C), der Zwischenwärmeübertragungsrohre (41A1, 41B1, 41C1, 41A2, 41B2, 41C2, 41A3, 41B3) und der Auslasswärmeübertragungsrohre (42A1, 42A2, 42A, 42B, 42C) verringert wird.
4. Radiator nach einem der Ansprüche 1 bis 3, wobei jeder der Kältemittelströmungsdurchgänge (34A, 34B, 34C, 34D, 34E, 34F) so ausgebildet ist, dass das Kältemittel von dem Einlasswärmeübertragungsrohr (40A, 40B, 40C) einer oberen Stufe zu dem Auslasswärmeübertragungsrohr einer unteren

Stufe (42A1, 42A2, 42A, 42B, 42C) zirkuliert.

5. Radiator nach einem der Ansprüche 1 bis 4, der ferner mehrere Wärmetauschteile (45, 46) umfasst, die aufwärts und abwärts unterteilt sind, wobei jeder der Kältemittelströmungsdurchgänge (34A, 34B, 34C, 34D, 34E, 34F) so ausgebildet ist, dass das Kältemittel von dem oberen Wärmetauschteil (45) zu dem unteren Wärmetauschteil (46) fließt.
6. Radiator nach einem der Ansprüche 1 bis 5, wobei jeder der Kältemittelströmungsdurchgänge (34A, 34B, 34C, 34D, 34E, 34F) ein erstes Zwischenwärmeübertragungsrohr (41A1, 41B1, 41C1), das sich zu dem Einlasswärmeübertragungsrohr (40A, 40B, 40C) fortsetzt, und ein zweites Zwischenwärmeübertragungsrohr (41A2, 41B2, 41C2) oder ein drittes Zwischenwärmeübertragungsrohr (41A3, 41B3) enthält, das sich zu dem Auslasswärmeübertragungsrohr (42A1, 42A2, 42A, 42B, 42C) fortsetzt, und ein Zwischenkopfstück (44) enthält, das mit allen ersten Zwischenwärmeübertragungsrohren (41A1, 41B1, 41C1), zweiten Zwischenwärmeübertragungsrohren (41A2, 41B2, 41C2) oder dritten Zwischenwärmeübertragungsrohren (41A3, 41B3) der Kältemittelströmungsdurchgänge (34A, 34B, 34C, 34D, 34E, 34F) verbunden ist.
7. Radiator nach einem der Ansprüche 1 bis 6, wobei die Wärmeübertragungsrohrgruppe (33) in mehreren Reihen und Stufen in die Plattenfinnen (31) eingesetzt ist, und die Einlasswärmeübertragungsrohre (40A, 40B, 40C) in einer Reihe auf einer leewärtigen Seite mit Bezug auf die Auslasswärmeübertragungsrohre (42A1, 42A2, 42A, 42B, 42C) angeordnet sind.
8. Kühlungszyklus unter superkritischem Druck, umfassend:

den Radiator nach einem der Ansprüche 1 bis 7 und einen Kältemittelschleife mit geschlossenem Zyklus (15), der einen Kompressor (16) zur Druckbeaufschlagung eines Kältemittels auf einen superkritischen Druck, eine Dekomprimierungsvorrichtung (20) und einen lastseitigen Wärmetauscher durch Rohrleitungen verbindet.

## Revendications

1. Radiateur pour rayonner la chaleur d'un réfrigérant qui est mis sous pression à la pression supercritique, le radiateur comprenant :
- plusieurs ailettes de plaque (31) s'étendant dans une direction verticale et disposées à un

pas prédéterminé ; et

une pluralité de passages d'écoulement de réfrigérant (34A, 34B, 34C, 34D, 34E, 34F) formés en parallèle par plusieurs groupes de tuyaux de transfert de chaleur (33) insérés dans les ailettes de plaque (31) à plusieurs étages, dans lequel :

la pluralité de passages d'écoulement de réfrigérant (34A, 34B, 34C, 34D, 34E, 34F) comprennent chacun un tuyau de transfert de chaleur d'entrée (40A, 40B, 40C) prévu dans des parties supérieures des ailettes de plaque (31), un tuyau de transfert de chaleur de sortie (42A1, 42A2, 42A, 42B, 42C) prévu dans les parties inférieures des ailettes de plaque (31), et un tuyau de transfert de chaleur intermédiaire (41A1, 41B1, 41C1, 41A2, 41B2, 41C2, 41A3, 41B3) prévu entre le tuyau de transfert de chaleur d'entrée (40A, 40B, 40C) et le tuyau de transfert de chaleur de sortie (42A1, 42A2, 42A, 42B, 42C), et

une surface transversale de passage d'écoulement des passages d'écoulement de réfrigérant (34A, 34B, 34C, 34D, 34E, 34F) est progressivement réduite des tuyaux de transfert de chaleur d'entrée (40A, 40B, 40C) aux tuyaux de transfert de chaleur de sortie (42A1, 42A2, 42A, 42B, 42C).

2. Radiateur selon la revendication 1, dans lequel : la surface transversale de passage d'écoulement des passages d'écoulement de réfrigérant (34A, 34B, 34C, 34D, 34E, 34F) est réduite par réduction progressive du nombre de circuits des tuyaux de transfert de chaleur d'entrée (40A, 40B, 40C), des tuyaux de transfert de chaleur intermédiaires (41A1, 41B1, 41C1, 41A2, 41B2, 41C2, 41A3, 41B3) et des tuyaux de transfert de chaleur de sortie (42A1, 42A2, 42A, 42B, 42C).
3. Radiateur selon la revendication 1, dans lequel : la surface transversale de passage d'écoulement des passages d'écoulement de réfrigérant (34A, 34B, 34C, 34D, 34E, 34F) est réduite par la réduction progressive des diamètres de passage d'écoulement des tuyaux de transfert de chaleur d'entrée (40A, 40B, 40C), des tuyaux de transfert de chaleur intermédiaires (41A1, 41B1, 41C1, 41A2, 41B2, 41C2, 41A3, 41B3), et des tuyaux de transfert de chaleur de sortie (42A1, 42A2, 42A, 42B, 42C).
4. Radiateur selon l'une quelconque des revendications 1 à 3, dans lequel : chacun des passages d'écoulement de réfrigérant (34A, 34B, 34C, 34D, 34E, 34F) est formé de sorte que le réfrigérant circule du tuyau de transfert de

chaleur d'entrée (40A, 40B, 40C) d'un étage supérieur au tuyau de transfert de chaleur de sortie d'un étage inférieur (42A1, 42A2, 42A, 42B, 42C).

5. Radiateur selon l'une quelconque des revendications 1 à 4, comprenant en outre une pluralité de parties d'échange de chaleur (45, 46) divisées vers haut et vers le bas, dans lequel :
- chacun des passages d'écoulement de réfrigérant (34A, 34B, 34C, 34D, 34E, 34F) est formé de sorte que le réfrigérant s'écoule de la partie d'échange de chaleur supérieure (45) à la partie d'échange de chaleur inférieure (46).
6. Radiateur selon l'une quelconque des revendications 1 à 5, dans lequel :
- chacun des passages d'écoulement de réfrigérant (34A, 34B, 34C, 34D, 34E, 34F) comprend un premier tuyau de transfert de chaleur intermédiaire (41A1, 41B1, 41C1) continu par rapport au tuyau de transfert de chaleur d'entrée (40A, 40B, 40C), et un deuxième tuyau de transfert de chaleur intermédiaire (41A2, 41B2, 41C2) ou un troisième tuyau de transfert de chaleur intermédiaire (41A3, 41B3) continu par rapport au tuyau de transfert de chaleur de sortie (42A1, 42A2, 42A, 42B, 42C), et comprend une colonne montante intermédiaire (44) raccordé à la totalité des premiers tuyaux de transfert de chaleur intermédiaire (41A1, 41B1, 41C1), des deuxièmes tuyaux de transfert de chaleur intermédiaires (41A2, 41B2, 41C2) ou des troisièmes tuyaux de transfert de chaleur intermédiaire (41A3, 41B3) des passages d'écoulement de réfrigérant (34A, 34B, 34C, 34D, 34E, 34F).
7. Radiateur selon l'une quelconque des revendications 1 à 6, dans lequel :
- le groupe de tuyaux de transfert de chaleur (33) est inséré dans les ailettes de plaque (31) dans plusieurs rangées et étages, et les tuyaux de transfert de chaleur d'entrée (40A, 40B, 40C) sont disposés dans une rangée du côté sous le vent par rapport aux tuyaux de transfert de chaleur de sortie (42A1, 42A2, 42A, 42B, 42C).
8. Cycle de réfrigération de pression supercritique comprenant :
- le radiateur selon l'une quelconque des revendications 1 à 7 ; et
- un circuit de réfrigérant en cycle fermé (15) raccordant un compresseur (16) pour mettre sous pression un réfrigérant à la pression supercritique, un dispositif de décompression (20) et un échangeur de chaleur du côté de la charge, par canalisation.

FIG. 1

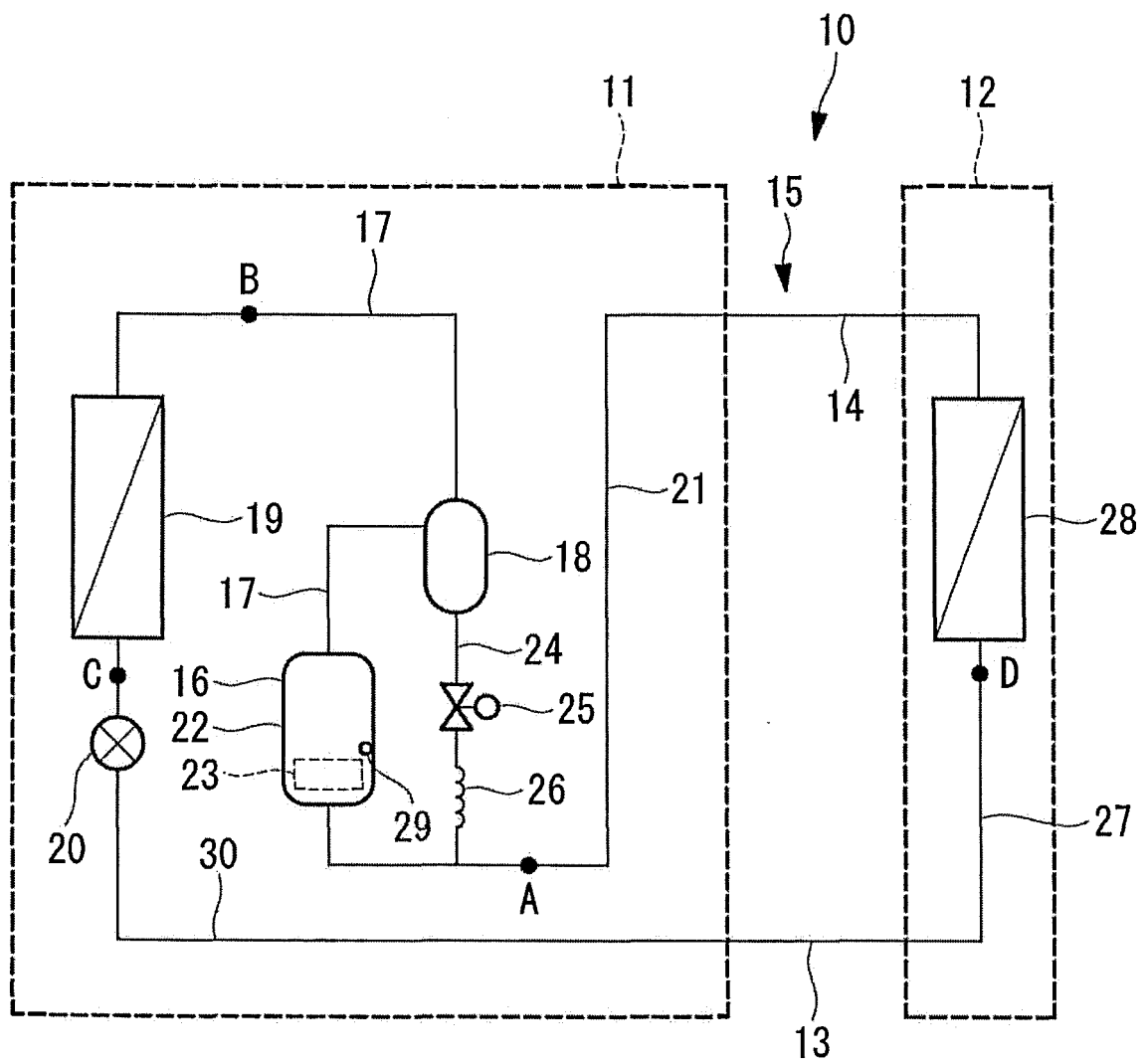

FIG. 2

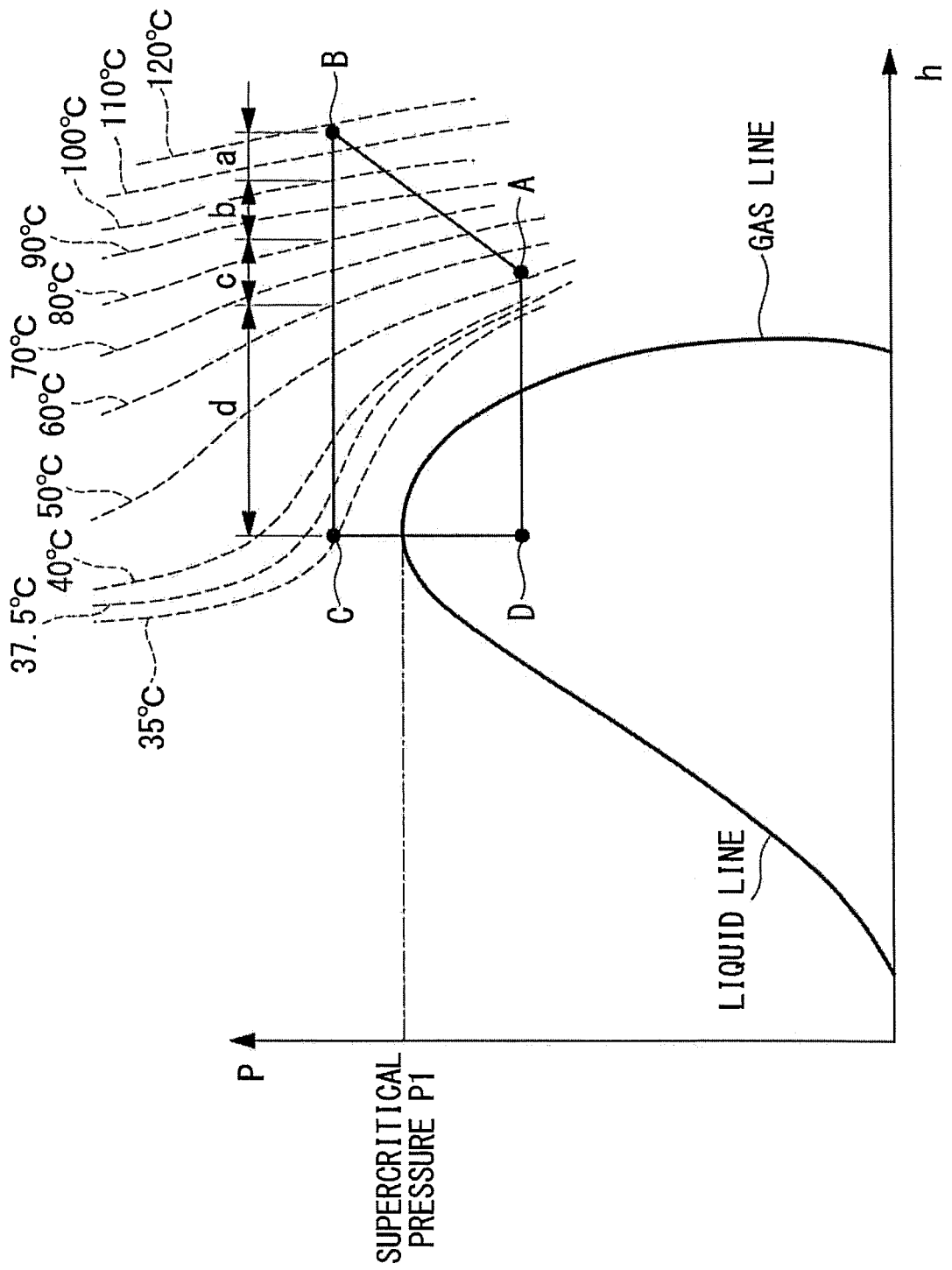

FIG. 3

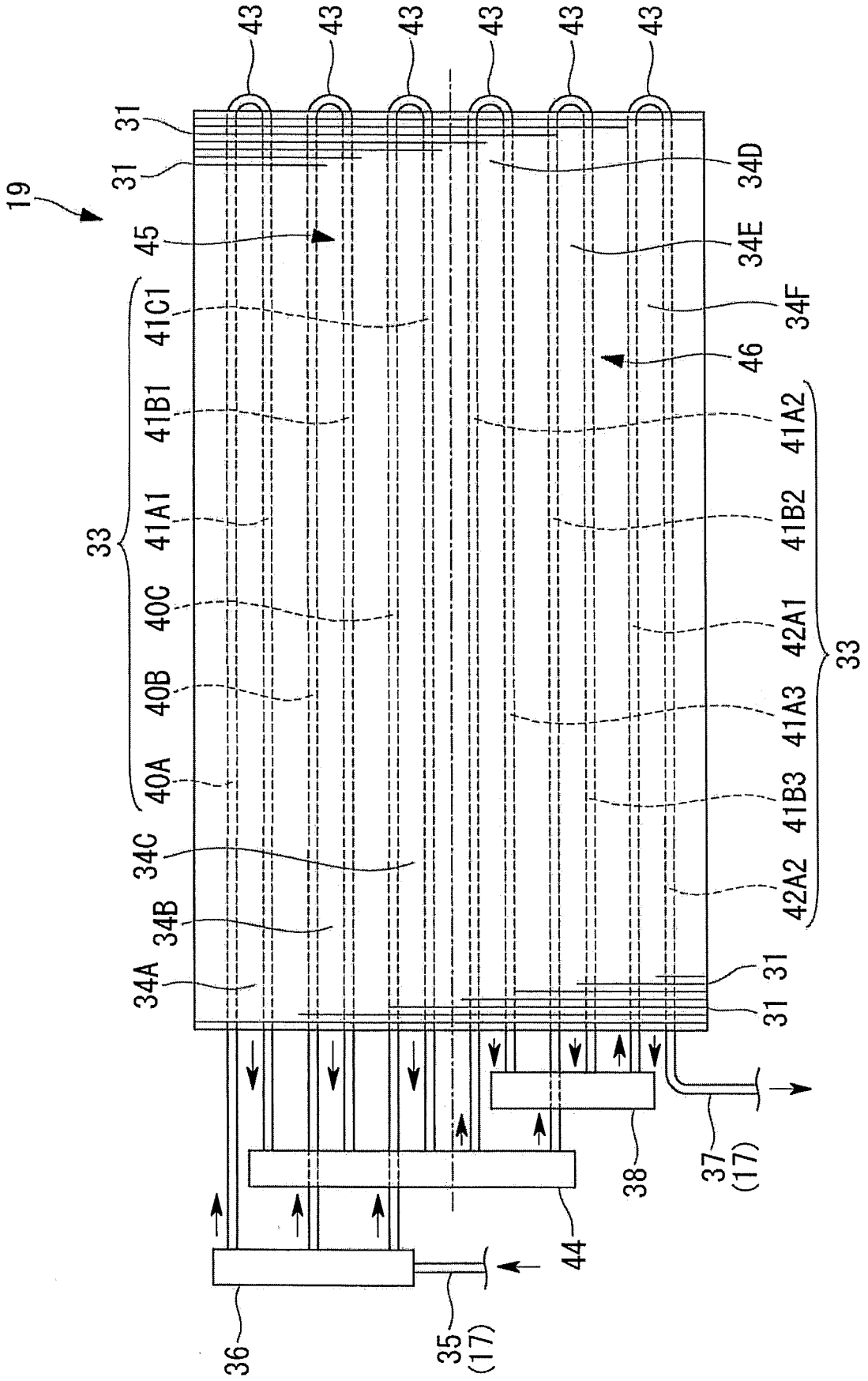

FIG. 4

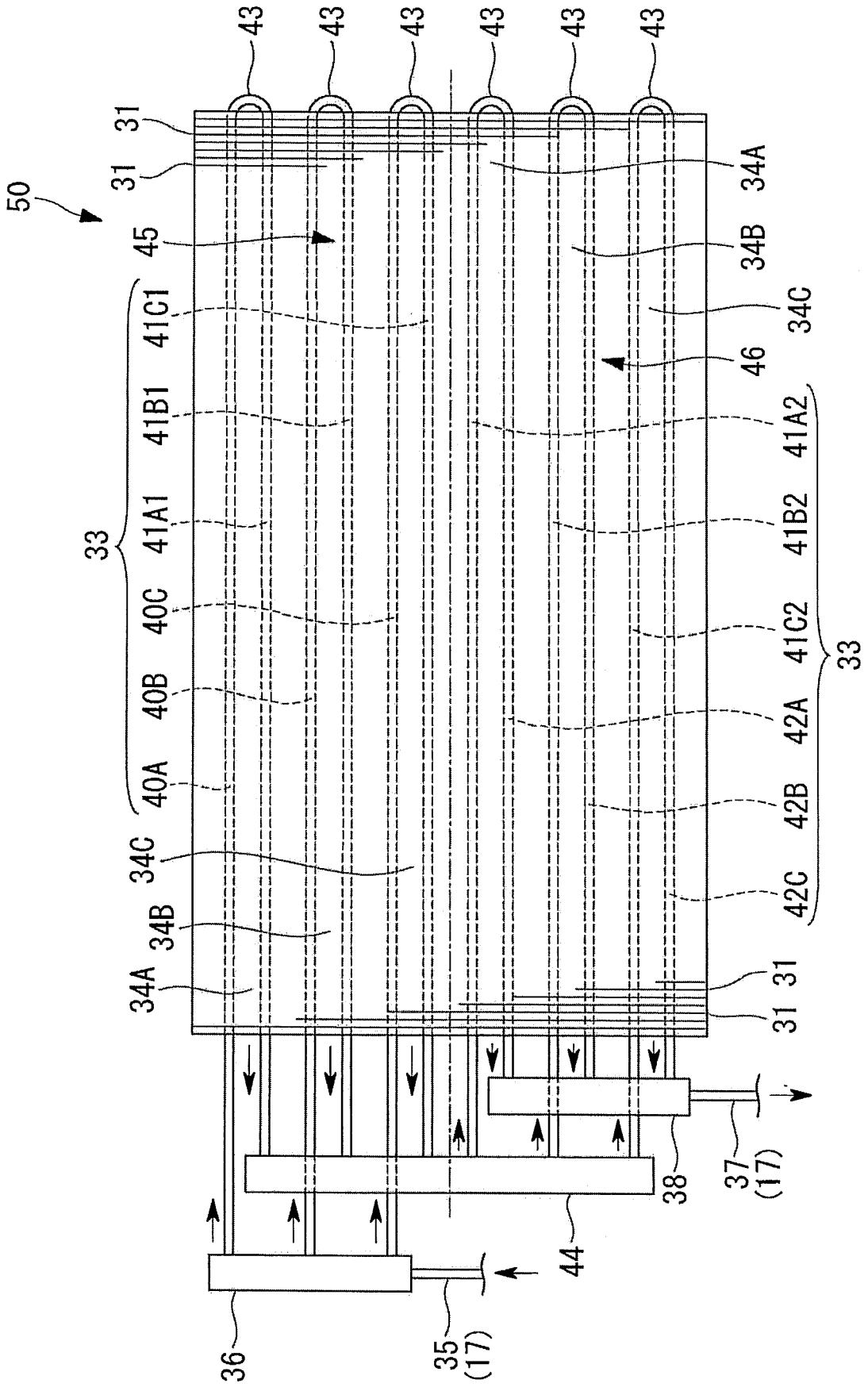

FIG. 5

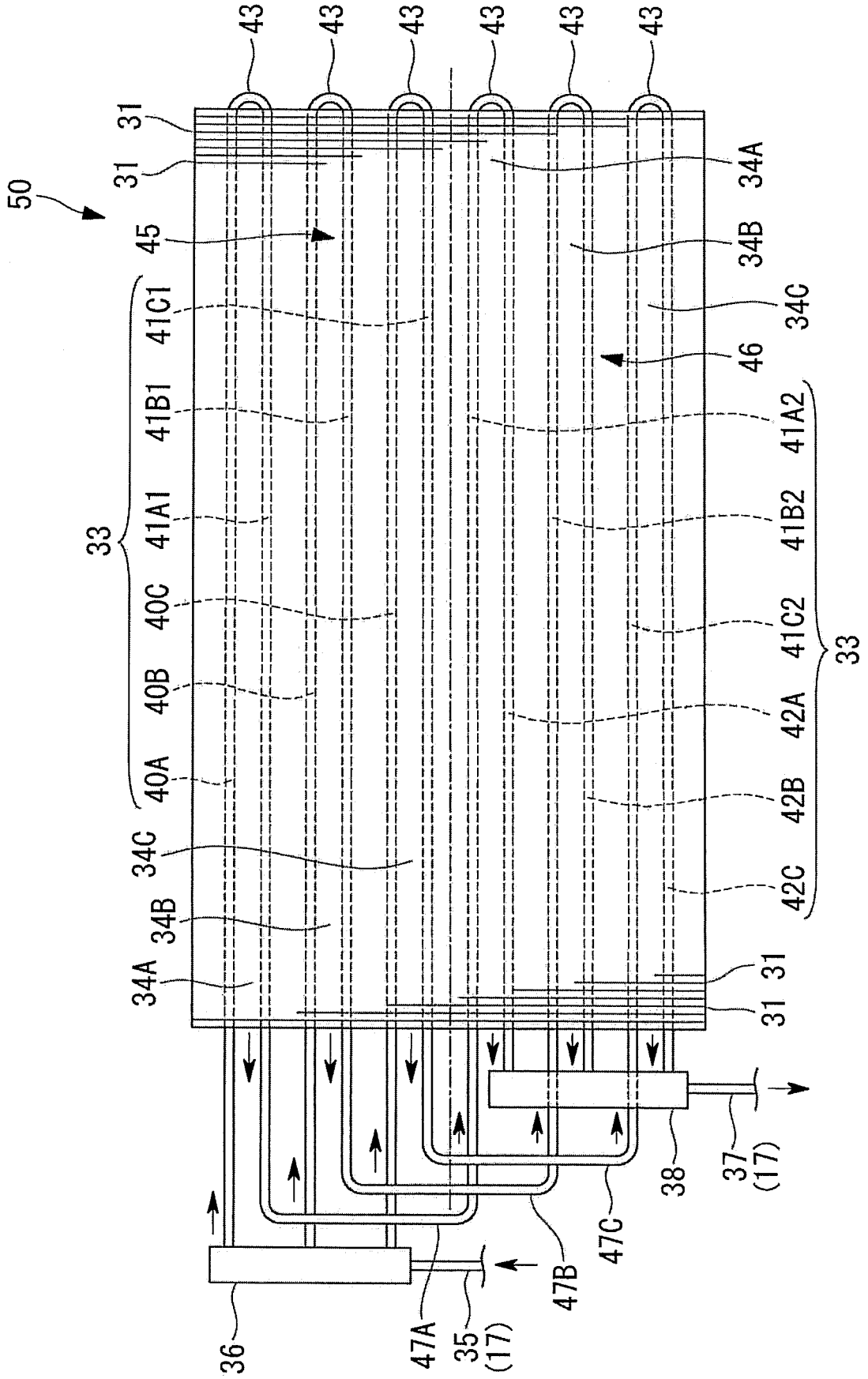

FIG. 6

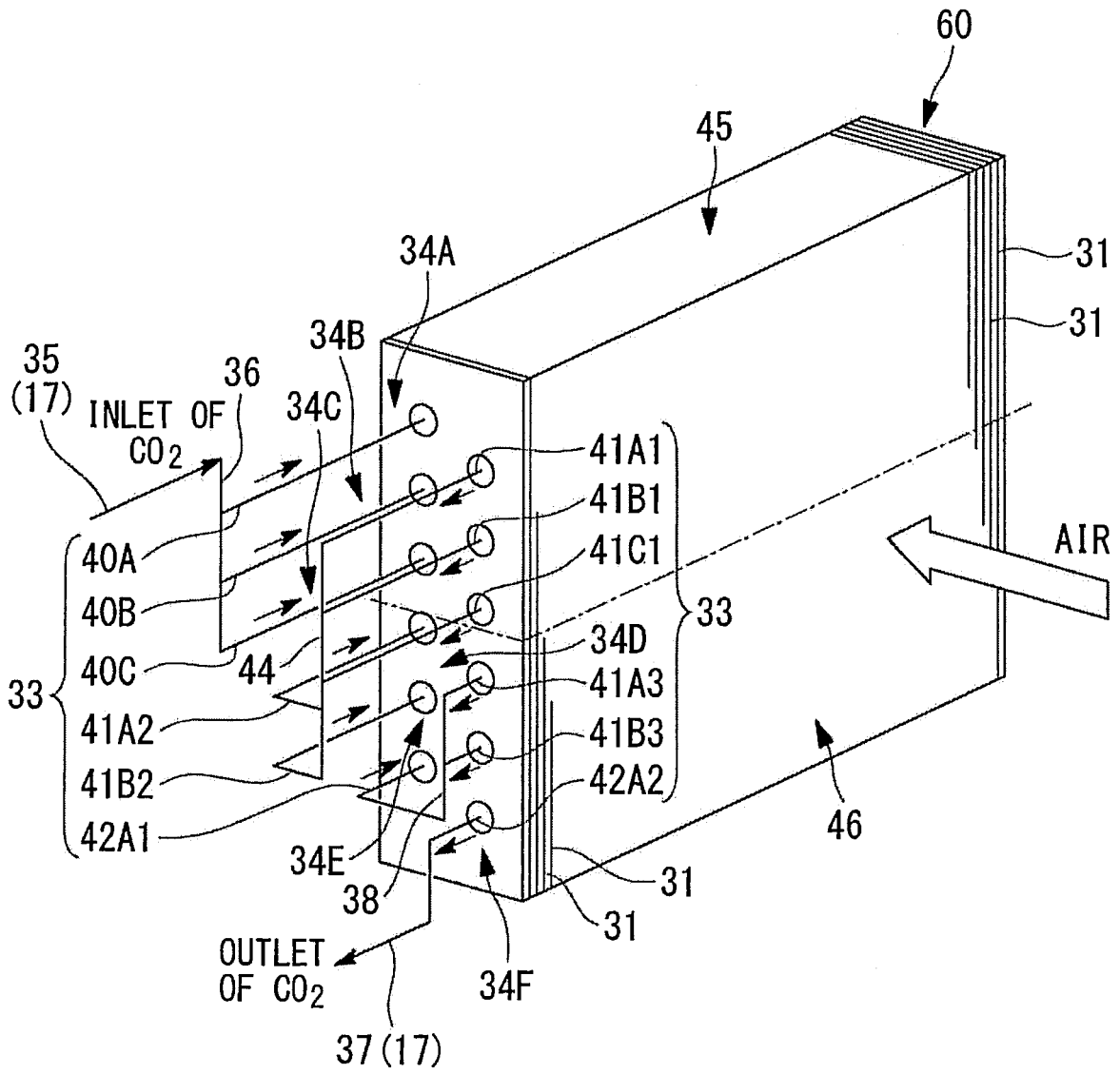

FIG. 7

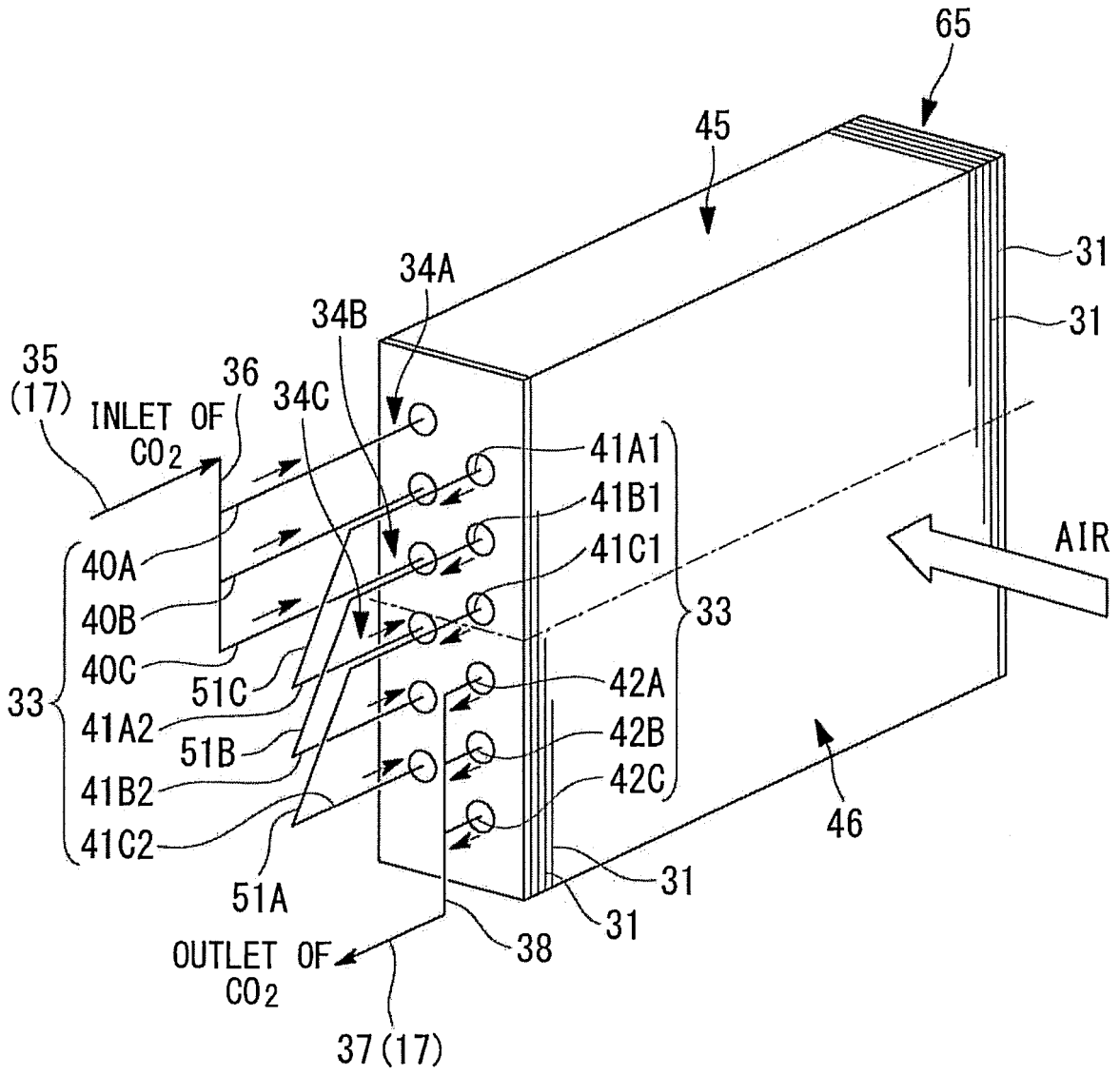
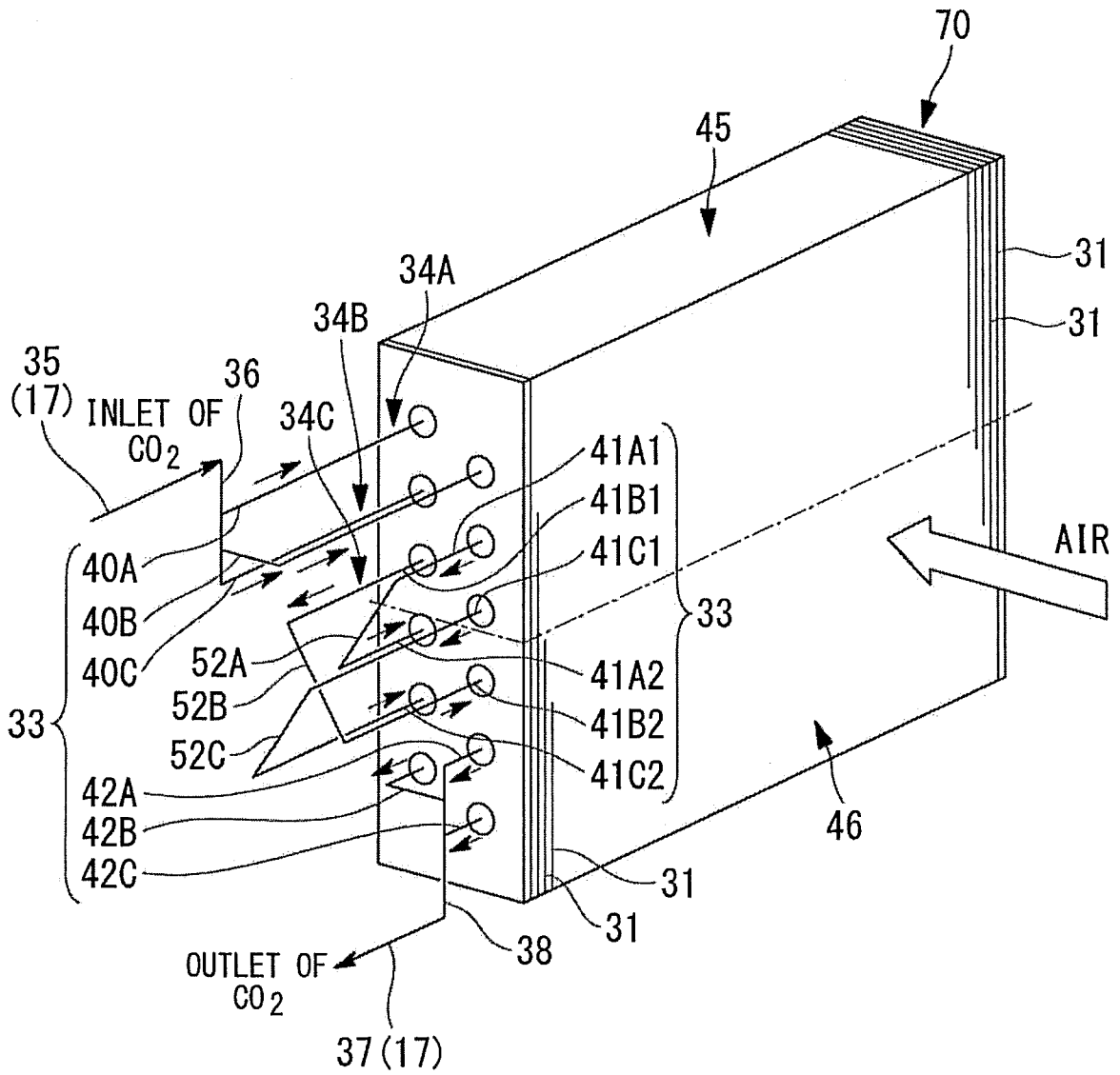

FIG. 8



**REFERENCES CITED IN THE DESCRIPTION**

*This list of references cited by the applicant is for the reader's convenience only. It does not form part of the European patent document. Even though great care has been taken in compiling the references, errors or omissions cannot be excluded and the EPO disclaims all liability in this regard.*

**Patent documents cited in the description**

- DE 10322165 A1 [0002]
- JP 2007232365 A [0003]
- JP HEI07208822 B [0004]
- JP HEI08121915 A [0004]