

A. N. CONSTANTINIDES.  
 PADLOCK.  
 APPLICATION FILED DEC. 28, 1914.

1,160,694.

Patented Nov. 16, 1915.

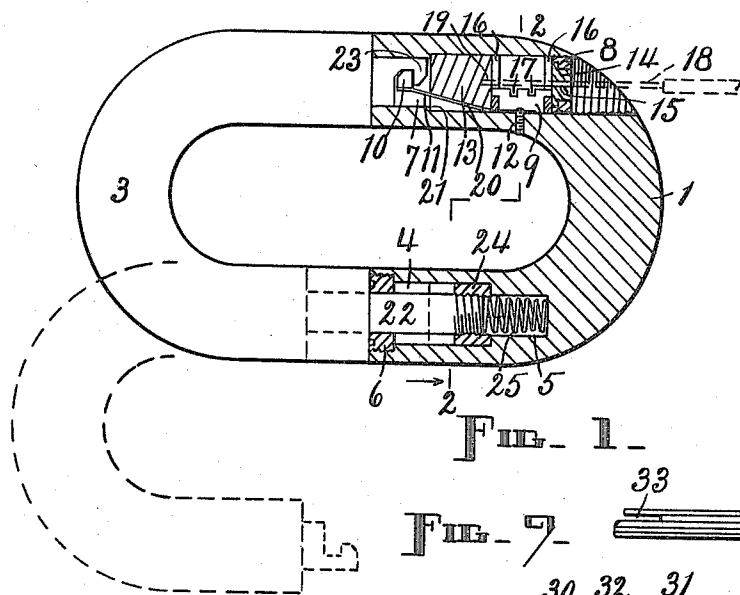

FIG. 1.

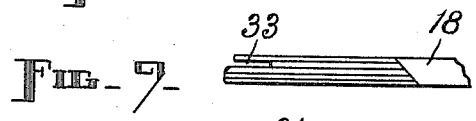

FIG. 7.

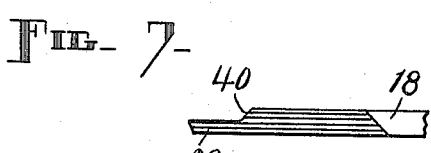

FIG. 8.

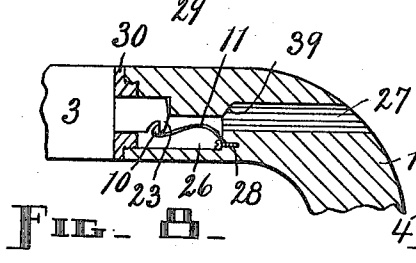

FIG. 9.

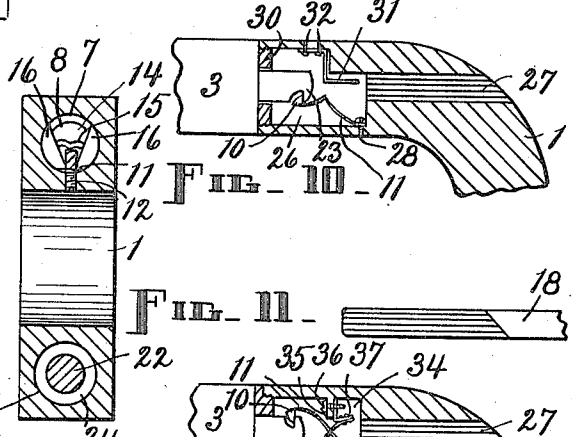

FIG. 10.

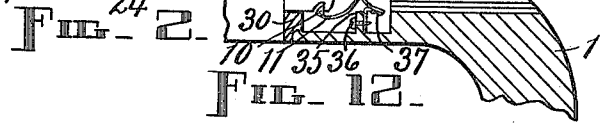

FIG. 11.

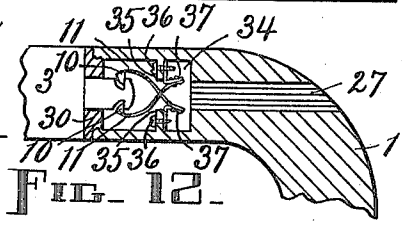

FIG. 12.

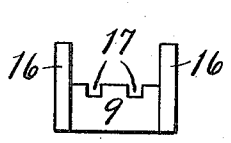

FIG. 3.

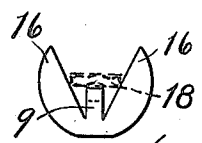

FIG. 4.

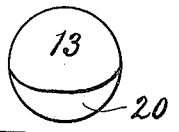

FIG. 5.

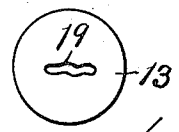

FIG. 6.

WITNESSES:  
*A. C. Fairbanks.*  
*H. H. Carter.*

INVENTOR:  
*Alexandre N. Constantinides,*  
 BY  
*Webster & Co.,*  
 ATTORNEYS.

# UNITED STATES PATENT OFFICE.

ALEXANDRE N. CONSTANTINIDES, OF STAMFORD, CONNECTICUT, ASSIGNOR OF ONE-FOURTH TO JAMES STARYEU, OF HOLYOKE, MASSACHUSETTS.

## PADLOCK.

1,160,694.

Specification of Letters Patent.

Patented Nov. 16, 1915.

Application filed December 28, 1914. Serial No. 879,338.

*To all whom it may concern:*

Be it known that I, ALEXANDRE N. CONSTANTINIDES, a subject of the King of Greece, and a resident of Stamford, in the county of Fairfield and State of Connecticut, have invented a new and useful Padlock, of which the following is a specification.

My invention relates to improvements in devices designed for use with staples or equivalent means for securing or locking doors, drawers, and other closures, and consists of a lock-provided body and a spring-pressed rotatable shackle of peculiar construction and arrangement, as hereinafter set forth.

One object of my invention is to produce a convenient fastener, for doors and the like, which embodies in a single or unitary structure complete in itself the advantages of a padlock and hasp, and on that account being as a rule stronger and more secure. This fastener is made available in a very few minutes with the aid of two staples or screws, one of which is set in the door or other movable member and the other in the door jamb or other fixed part adjacent to and quite near to the first.

A further object is to provide such a fastener which is comparatively simple in construction and operation, is adaptable to many uses, and is susceptible of various minor changes whereby different lock-operating means may be employed, and the availability of a given key or other lock-releasing element or means limited. With this device the range of locking and releasing means for the shackle is wide and not necessarily confined to keys and key-operated means. This fastener is especially useful to travelers for securing hotel and boarding-house doors, although by no means limited to such use.

Other objects and advantages will appear in the course of the following description.

I attain the objects and secure the advantages of my invention by the means illustrated in the accompanying drawings, in which—

Figure 1 is a side elevation in partial section of a fastener which embodies a practical

form of my invention; Fig. 2, a cross-section taken on lines 2—2, looking in the direction of the associated arrow, in Fig. 1; Fig. 3, an enlarged side elevation of the guard used in the fastener illustrated in the preceding views; Fig. 4, an enlarged end elevation of said guard; Figs. 5 and 6 are enlarged opposite end elevations of the lock or latch cam used in said fastener, and Figs. 7 to 12, inclusive, are side elevations in partial section of fragmentary parts of modified locking and releasing means, including the respective keys, there being three such modifications with their keys thus illustrated.

Similar numerals designate similar parts throughout the several views.

Before proceeding to describe my invention in detail, I desire to say that in general shape, both superficially and in section, and in size the fastener may vary to a very great extent, and that a large variety of modifications in the construction and arrangement of the locking and releasing means is possible, as already noted, and all these without departing from the spirit of the invention.

Referring to the first view, it will be observed that the fastener therein shown comprises a body 1 and a shackle 3, each being superficially U-shaped and rectangular in cross section, but not necessarily so. In one branch or arm of the body 1 and opening through the end of such arm is a chamber 4. Extending from the inner end of the chamber 4 still deeper into the body 1 is a recess 5. The outer end portion of the walls of the chamber 4 is internally screw-threaded to receive a nut which serves as a flange or stop member for the shackle 3, such member being indicated by the numeral 6. Extending clear through the other branch or arm of the body 1, so as to open through what may be termed the end of said body, as well as through the end of said arm, and therefore in parallel relation to the chamber 4 and recess 5, is a passage 7.

Rigidly secured within the passage 7, at the outer or key entrance thereto, is a plug 8, beyond this also rigidly secured within said passage is a guard 9. Within the passage 7, a short distance from the shackle end

thereof, is a lock or latch which comprises a head 10 carried at the outer end of a spring 11, the inner end of said spring being secured by one or more screws 12 to the wall of said passage. Normally the spring 11 retains the head 10 in the approximate center of the passage 7. A cam member or cam 13 is located in the passage 7. The plug 8 is provided with a rotatable flanged center or key-hole piece 14. The member 14 has a key-hole 15 therethrough, which may be made undulating so as to require a corrugated key for the lock. The key-hole piece 14 with its flange is held in place between the plug 8 and the guard 9, but is free to turn in said plug and in contiguous relation to said guard. The guard 9 is provided at each end with arms 16 which assist in locating and securing the device in place. One or more notches 17 are cut in the inner edge of the guard 9, and a key which can be turned, after being inserted in the key-hole 15 and pushed past said guard into engagement with the cam 13, must be notched to correspond with said guard, as will readily be understood.

A key 18 is represented by broken lines, in Fig. 1, as being in position ready to unlock the latch, and in Fig. 4 the same key is similarly indicated. The end of the cam 13 which is contiguous to the guard 9 is provided with a slot 19 to receive the end of the key 18 after said key has been passed through the key-hole 15 and by said guard. This end of the cam 13 is approximately of the same diameter as the passage 7, but said cam tapers on one side, as represented at 20. The tapered side 20 receives the latch spring 11, when the cam 13 is normally disposed, and so permits the latch head 10 to be located in the approximate center of the passage 7, but when said cam is given a quarter turn, as with or by means of the key 18, an untapered part of said cam encounters the free portion of said spring and forces it over against the wall of said passage, thus removing said head from the aforesaid location. When the cam is turned back again to bring the tapered side 20 into contact with the spring 11, the latter immediately acts to relocate the head 10 in the position previously described as normal, that is, in locking position. The cam 13 is held against endwise movement by the guard 9 and a shoulder 21 in the passage 7.

The shackle 3 has at one end a stem 22 which operates in the chamber 4, and at the other end a hook 23 which is receivable in that part of the passage 7 in which is located the latch head 10; the shackle ends just mentioned being the ends of the shackle branches or arms. The stem 22 operates in the stop member 6, and has a screw-threaded inner terminal upon which a check collar 24

is screwed. A spring 25 is inserted in the recess 5 and bears against the inner end of the stem 22. The collar 24 projects beyond the inner end of the stem 22 to receive and guide the outer end of the spring 25. The office of the spring 25 is to force the shackle 3 outwardly, when said shackle is unlocked, until the collar 24 comes into contact with the stop 6, when said shackle can be turned on the stem 22 as an axis and with said stop and the wall of the chamber 4, with which said collar is in contact, as bearings. In Fig. 1 the shackle is represented by broken lines in its outward position and thrown or reversed. In assembling, the stop 6 is first slipped onto the stem 22, next the collar 24 is screwed onto said stem, and then, after the spring 25 is introduced into the recess 5, said stem and collar are inserted in the chamber 4 and said stop is screwed into the open end of said chamber.

The latch head 10 and the hook 23 are provided with the usual beveled surfaces, as shown, to enable said hook to force said head, which normally is positioned in the path of said hook, out of the way until the hook enters the passage 7 far enough for the head to enter into locking engagement therewith. Thus, to lock the shackle 3, it is only required to position said shackle with its hook 23 in line with the passage 7, and then to force said shackle toward the body 1, against the resiliency of the spring 25, until said hook 23 is within the grasp of the latch head 10, the shackle being turned if necessary and moved longitudinally on its stem 22 which operates in the stop 6 and never becomes disengaged from said body.

The unlocking of the shackle is effected through the medium of the key in the manner hereinbefore quite fully explained. By means of the key the cam 13 is turned to actuate the latch out of engagement with the hook 23, and then the spring 25 acts to throw the shackle outwardly and carry said hook out of the passage 7. The cam 13 should then be turned back to relocate the latch in locking position, so that the hook can be snapped into place again, although the key might be used for locking purposes.

In Fig. 8 I show a modified and simplified lock or latch operating means. Here, instead of the passage 7, an irregular shaped chamber 26 and a corrugated key-way 27 are formed in the body 1, the former opening through the end of the arm in which it is located, and the latter opening through the end of said body. A latch spring 11 and head 10 are provided as before, but in this case the spring is fastened by means of a screw 28 at the inner end of the chamber 26, and said spring is formed with a bow that normally projects beyond or in front of the key-way 27, which latter at its inner

end opens into said chamber. The key 18, shown in Fig. 7, is corrugated to fit the key-way 27, and has an extension 29 to enter the chamber 26 and engage the bowed part of the latch spring, when said key is inserted and pushed forward in said key-way, with the result that said spring is operated to withdraw the head 10 from the hook 23. When unlocked and released in this manner the shackle 3 is free to be manipulated as in the first case, and said shackle can be locked either with or without the aid of the key as previously explained. The chamber 26 is constricted at the outer end by means of a nut 30 which may be screwed into such end, the opening in such nut being large enough to admit the hook 23 to said chamber. This construction makes it convenient to place the latch in the chamber 26 and secure the spring 11 with the screw 28.

The modification illustrated in Fig. 10 differs from that illustrated in Fig. 8 in that an angular guard 31 is provided in the chamber 26, such guard being secured to the wall of said chamber by a pair of screws 32, the spring 11 is acutely bent, instead of being bowed, and the screw 28, which secures said spring in place, passes through the wall of said chamber, instead of into the end thereof. Both the free terminal portion of the guard 31 and the bend in the latch spring extend over or in front of the inner end of the key-way 27. The key 18 for this lock or latch has a slot 33 therein, as shown in Fig. 9, to enable said key, when thrust into the key-way 27, to pass far enough into the chamber 26 to engage and act on the latch spring. The operation is similar to that hereinbefore described. A reducing nut 30 may be provided here as in the Fig. 8 construction, and for a similar reason, that is, to afford means for partially closing the outer end of the chamber 26 after the guard and latch have been inserted and the screws 32 and 28 seated.

Double latch mechanism, which is adapted to be operated by the thrust from a key, as in the other two modifications herein shown and described, is provided in the construction shown in the last view. In this construction the corrugated key-way 27 is present and there is a connected cylindrical chamber 34 in the body 1, into which chamber project from the wall thereof two lugs 35. Attached by screws 36—36 to the lugs 35 is a pair of resilient angular arms 37. The free terminals of the arms 37 are arranged in relative flaring or divergent relationship, and secured to such terminals is a pair of latch springs 11 having heads 10. The two springs cross each other as shown, and they have a compound curve formation or configuration which enables their heads to engage a double hook 38 with which the shackle 3 is equipped.

The key 18 provided for this construction, when thrust through the key-way 27 into the chamber 34, encounters the inner ends of the springs 11 and forces them, together with the terminals of the arms 37 to which said springs are attached, farther apart, thereby rocking or tilting said springs in such a way and to such an extent that their heads are actuated out of engagement with the double hook 38. The operation of this device in the other particulars will be understood from what has gone before. There is a reducing nut 30 at the outer end of the chamber 34.

The inward thrust of the key, in the Fig. 8 construction, is limited by a shoulder 39 at the inner end of the key-way 27, and a shoulder 40 on said key. The guard 31, in the Fig. 10 construction, limits the inward thrust of the key when the inner end of the slot 33 arrives at the free end of said guard. In the last construction the arms 37 at their more adjacent parts check the inward movement of the key, after the free terminals of said arms have been spread thereby.

Although the modified forms of construction may be somewhat cheaper to produce than the first construction, and are capable of being more quickly unlocked, since the key does not have to be turned after being thrust into any of the key-ways 27, said first construction is safer or more secure and excels in other respects. This refers only to the latch or locks, as the other features of the fastener are not changed.

What I claim as my invention, and desire to secure by Letters Patent, is—

1. The combination, in a padlock, with a body having an opening therein, and a stop member screwed to the outer end of said opening, of a shackle provided with a part that extends through said stop member into said opening, a collar screwed onto the inner end of such part, the latter with said collar being reciprocable and rotatable in said opening, a spring between the inner end of said opening and the inner end of said part, said collar projecting beyond said inner end of said part to encircle the adjacent terminal of said spring, and locking means for said shackle.

2. The combination, in a padlock, of a double-armed body chambered at the ends, and having a key-hole extending from the chamber in one arm through the end of such arm which joins the intermediate part of said body, a double-armed shackle having a part arranged to reciprocate and rotate in the chamber in the other arm of said body, and having a latch-engaging part receivable in said first-mentioned chamber, a latch in said first-mentioned chamber, and a key receivable in said key-hole to actuate said latch out of engagement with said latch-engaging part.

3. The combination, in a padlock, of a double-armed body having an opening therein, a double-armed shackle having a part arranged in reciprocable and rotatable relation to one arm of said body, and having a latch-engaging part receivable in said opening, a spring latch in said opening, a cam in said opening, such cam having a key slot and being adapted to actuate said latch out of engagement with said latch-engaging part, a key guard in said opening, and a key-hole member in said opening.

ALEXANDRE N. CONSTANTINIDES.

Witnesses:

JOHN SIGALOS,  
GEORGE R. CLOSE.

Copies of this patent may be obtained for five cents each, by addressing the "Commissioner of Patents, Washington, D. C."