



3

trim sets) (latching mechanism) (mortise lock mechanisms) (handle mortis lock mechanism) (retracting) (free-wheel)" (

(door) (secured)

(opposite sides) (shaft)

(tail) (key-operated cylinder lock) 가

(cylinder lock tail)

(latchbolt) 가

kages) (deadbolt) 가 (lin

가 (hinged) 가

가 가

3 가 /

가

가 (reverse)

(deadbolt throw lever)

가

" " ( )

가

가

2

가

가 (single piec

e)

(vertical rod latches)

(solid shaft)

(strength)

(security) (lever handle controller)

가

가

가 (vandal)

(thief)

가

(f

unctionality)

가

가

가

가

가

(torque)

( )

가

가 1 2 (halves) 가 1

(lock function receiver)

가

1 2

1 2

가

가

1 ( 가 )  
2

2 가

1 가 2 ( 가 )  
가

1

1 ( 가 )  
2 1 2 가

1 2 가 , 1 2  
1 2 가 1 ( 1

(sliding motion)

가 1)

1 ), 2)

2 ( 2

(torque forces)

(loads) 가

(notch)

1

(cam)

(hook)

(curvature)

가

가

(arcuate groove)

가

(lock cam)

(plate)

(scale)

가

1  
nstallation)

(가 )

(i

1a

2

2

(decorative plate)

(clarity)

, 1  
, 1

3  
 3a 3 , 2 (two-piece handle shaft)  
 3b 3  
 4a  
 4b 4a  
 4c 4a  
 5  
 6

( ) 1 6

1 (10), (10) (18) (1

2), 14 (16) (10) (fit) (20) (22,24) (18) (26,28) (10) (1

0) (20) (14) (12) (10) (30) (34) (32) (30)

(32) (12) (30) (34) (32) (30)

(32) (12) (38) (10) 3 (10) (40)

) (32) (40) (32) (tail)( 3 ) (10) (32) (42) (34)

(34) (44)가 (10) (48)

(12) (50) (10) (46) 2 (18) (48)

(12) (52) 1a (10) 3 (52) (10) (52) (10)

e)(54)가 (54)가 (blade slot)(56) (bearing holds) (pivoted) 가 (piec

(58) 가 (52) (12) (58)

(blade-shaped shaft) (52)

(12) (10) 3 (40)

(10)가 (34) (34) ), (52) (1

2) (52) (58) ( ) , ( )

(50) (46) ( )

(14) (60) (10) (50) (62)

(throw lever; 2 ) (58) (52)

(64) 가 1a (5)

2) (58) (12) (66)

(60) (62) (66)

(68,70,72 74) (existing installing) (10)

2 (10) (32)가 (40) (40) (34) (76) ( 3b ) (40) (12) (36) (studs)(80,82) (68 70) (84,86) 1 (10)가 (88) ), (50) (32)가 ( ( (10) (44)가 ), (60) (30) (50) (90)가 1 3 (30) (92) (3) 6) (96) (washer)(94) (36) (36) (98) (30) 가 2 (46) 1 (100) (106) (104) 3b (46) 1 (100) 2 (106) (106) (50) 2 (100,106) (109) (109)가 (100) (108) (108) (30) (108) (114) (116) (118) (36) (114) (120) (tab)(120) (122) (108) (108) (122) (120)가 (112) (108) (108) (pull down) (30) 가 (swing) (reverse) (11 4) (118) (108) (same functionality) 가 (122) (126) (124) 2 (46) 2 (100,106) 2 2 (10) (50) (90) 2 (106) 2 (30) (106) (vertical rod door mechanism), (106) 1 2 (100 (100) (104) 2 (106) (ball) (so cket joint)가 3 4a 4c (46) 2 (100 106) (coupling) (uncoupling) (46) (128) (110) (172) 2 (110) (178) 2 (170) (46) (172) 2 가 가 (46) (128) 가 가 (32) ), (170) 2 (100,106) (110)가 ( (32) ), (170) 2 (100,106) 가 (100) (106) (110) 1 2 (100) 2 (106) (170)가 (110) (170)가 (172) (110) 1 4a 4c 3 가 4c (172) (46) (170) 1 (100) 174 (172) (170) 2

2 (106) 176 (46) (128)  
 가 (172) (172) (172)  
 , (172) (178) (110)가  
 , (46) (178) (46) (178) ( )  
 4c 가 (172 178) 4 4 (180,182,184 186)  
 . 4 (184 186) 1 (106) 4 (180 182) (100) 1  
 (106) 4 186 184 (46) 2 (100) 4 182 180  
 4a 가 , 2 , 4 (184 186) 2 가  
 (106) (110) (170) 1 (4)  
 (184)) (4 (186)) 2 (106) (108)  
 1 (100) (110) 2 (106)  
 4b 1 , 1 (100) , (172) (174)  
 (100) 1 (4 (180)) (110)가  
 4 (180) (100) , 4 (180) (188,190 192) 1  
 (100) , (100) 가 (106)  
 , 4 (182) (100) , 1 (100)  
 (194 196) V 4 (180)) (100) 4 (1  
 82) 4  
 (110) (200) ( ) 3 3a  
 ). (200) (198)( 4a 4b ) (202) (2  
 02) 가 (106) (100) (106) ) (110)  
 (110) (200)가 , (110)  
 (198) (36) (200) (stationary)  
 (202) (198) (170) 1  
 (180,184) (46) (200) (204) (center of curvature) 가  
 3 3a (204) 가 (52)( 1a )  
 (58)  
 C- (C-clip)(210) (208) (plate : 206) 가 (206)  
 가 (depression)(214) (206) 가 (212) (36)  
 가 (212)  
 (200) (206) (206)  
 (216,218) 가 (204) (58)가 (220,  
 222) ( 5 )  
 (58) (224) (226) (110)( 5 )  
 (arms)(228,230) (226)  
 가 (32) , (76)  
 58) (204) (46) 4 (182 186) (52) ( )  
 (202) (198)  
 가  
 4 (180 184) (58) (204)  
 2 (100 106)

2 (100,106) (110)가 2 (100,106) (110)가 (130,132) (134)

(136) 3 (110) / 가

(110)( 2 (106) (100) ) (torque carrying connection) (100) (122) ( )

(120) 가 (106) (122) 가 ( 60 ) (198) (202)

138) (138) (122) ( )

(57)

1.

(mortise lock) (free-wheeling handle controller) ,  
 (latch bolt) ,

가 (retracting) 가 ,

(body) ;  
 (handle) ;

가 ;  
 (shaft) , 가 1 2

가 , 1 ; 가 , 가 (lock function receiver)

가 (shaft lock) ,

1 2 1 2

2.

1 ,

3.

1 ,

4.

3 ,

5.

1 ,

6.

5 ,

1

2

가

2

가

1



16

19.

18

20.

19

가

(fastener) 가

(recess)

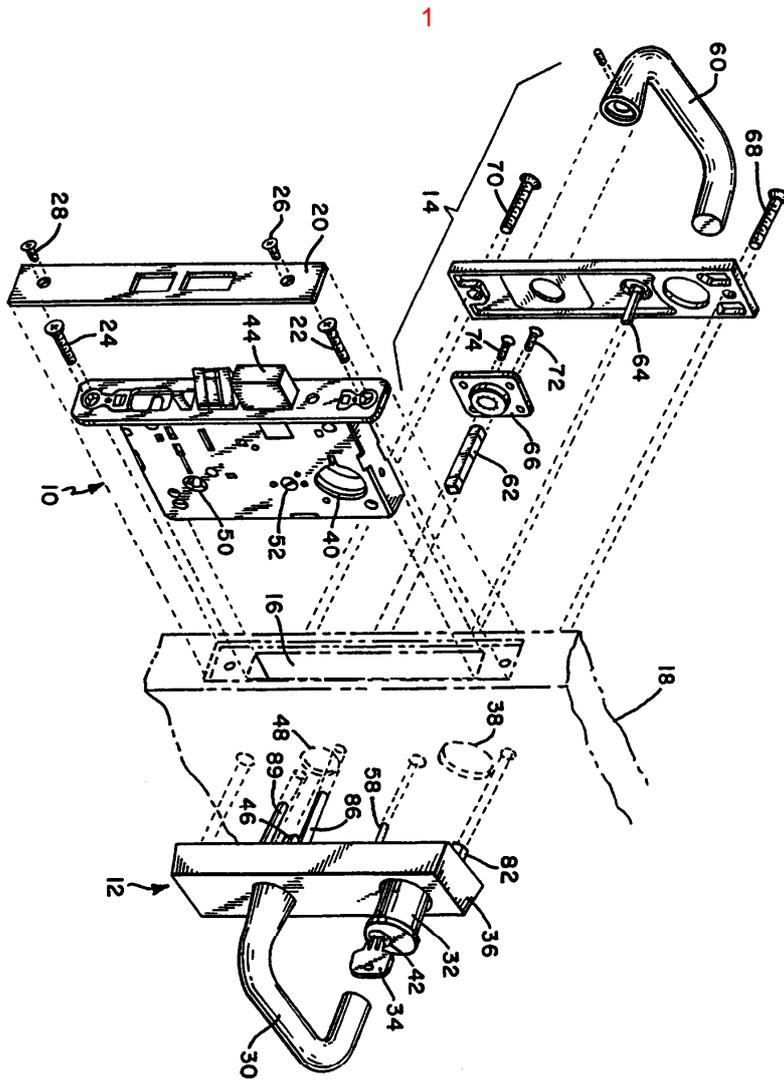

1

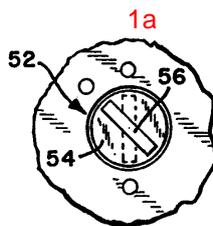

1a



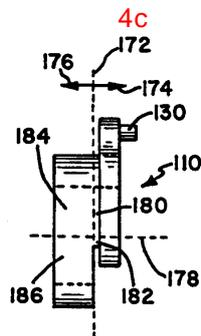
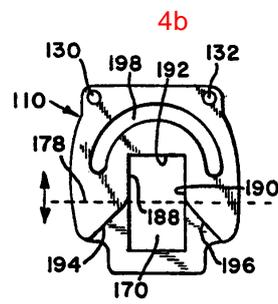
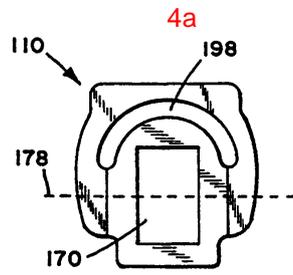
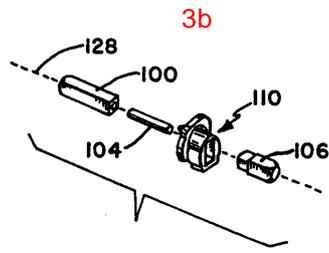

5

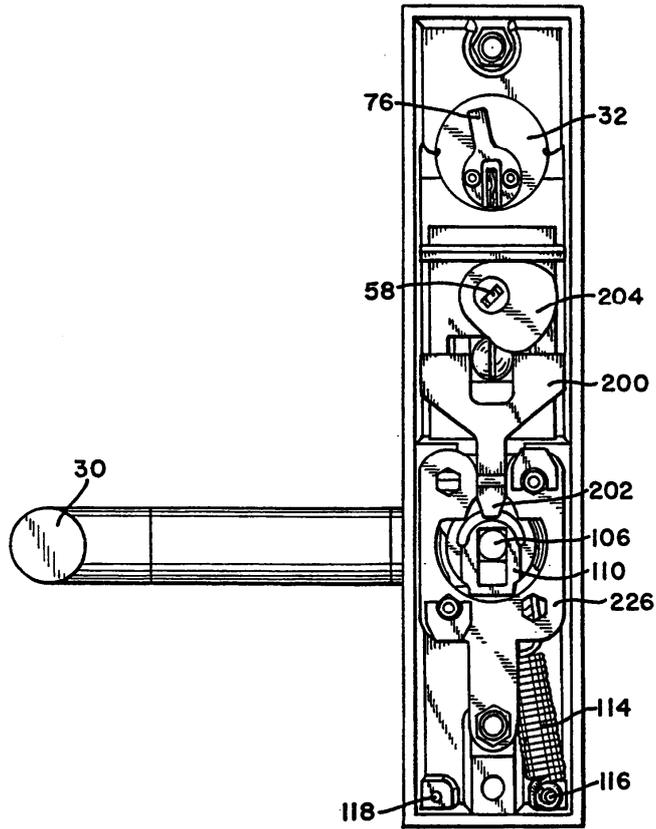

6

