

(No Model.)

2 Sheets—Sheet 1.

H. BIRKHOLZ.
SPIRAL CONVEYER.

No. 415,604.

Patented Nov. 19, 1889.

Fig. 1.

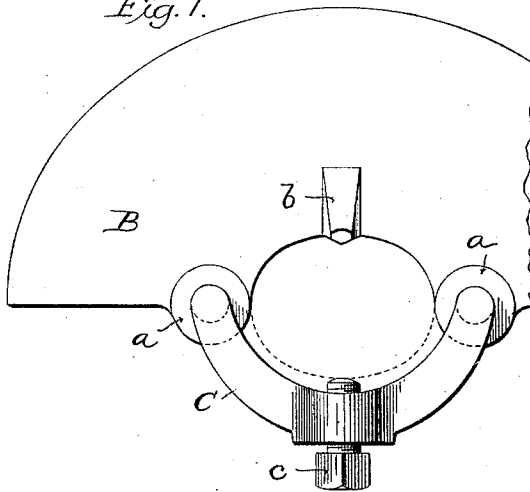

Fig. 2.

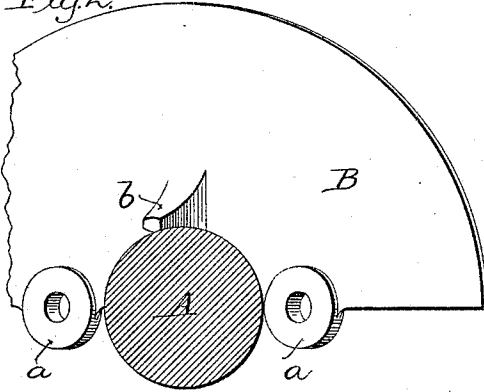

Fig. 3.

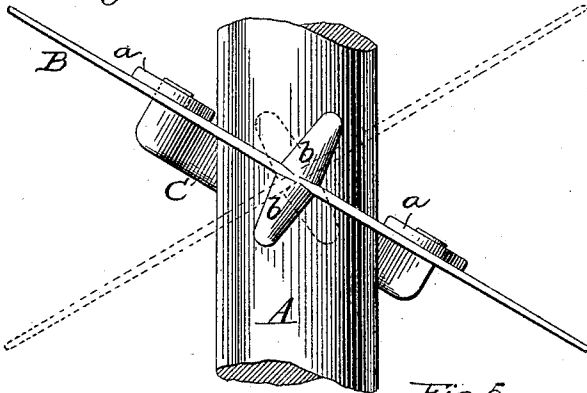

Fig. 4.

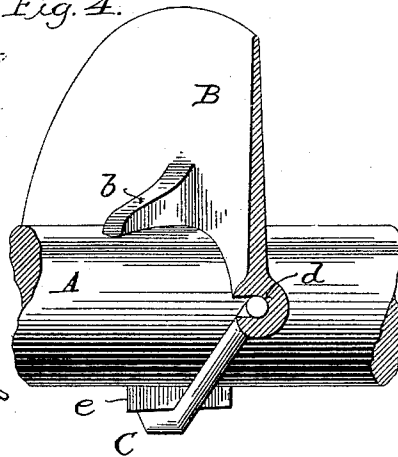
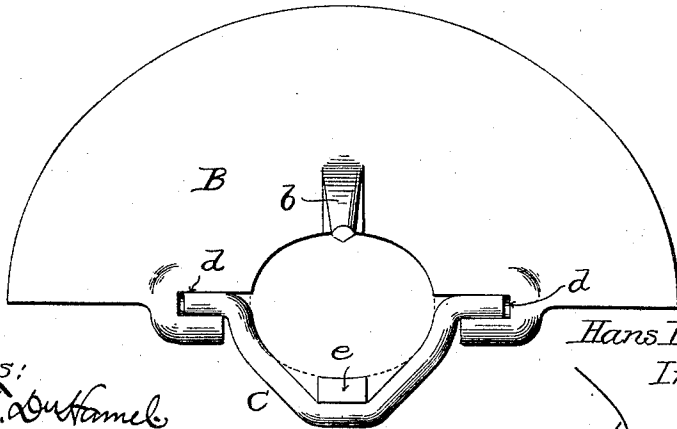

Fig. 5.



Witnesses:
James F. DuHamel
Walter S. Dodge

Hans Birkholz,
 Inventor,
 by *Rodger Son,*
 his Attys.

(No Model.)

2 Sheets—Sheet 2.

H. BIRKHOLZ.
SPIRAL CONVEYER.

No. 415,604.

Patented Nov. 19, 1889.

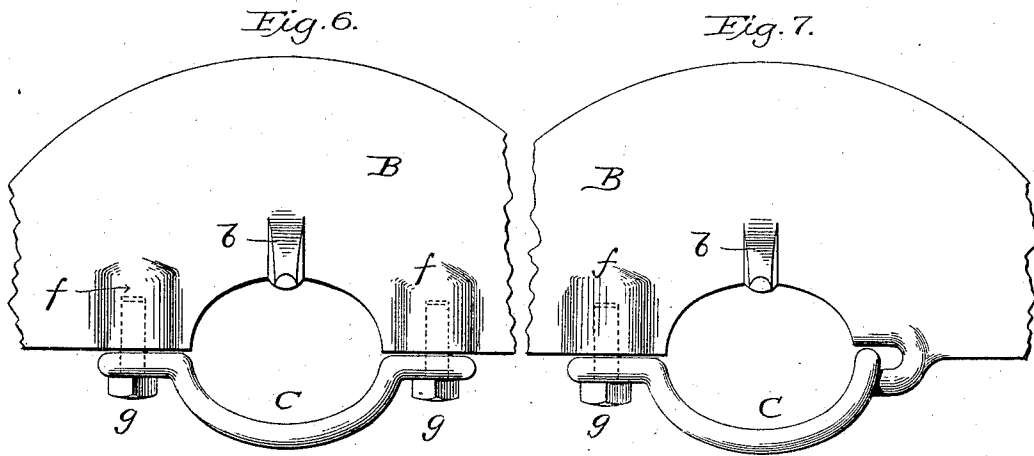

Witnesses:

James F. Duffemel
Walter S. Dodge

Hans Birkholz,
Inventor,

by Dodger Son,

his Attys.

UNITED STATES PATENT OFFICE.

HANS BIRKHOLOZ, OF MILWAUKEE, WISCONSIN, ASSIGNOR TO EDWARD P. ALLIS, OF SAME PLACE.

SPIRAL CONVEYER.

SPECIFICATION forming part of Letters Patent No. 415,604, dated November 19, 1889.

Application filed October 4, 1886. Serial No. 215,312. (No model.)

To all whom it may concern:

Be it known that I, HANS BIRKHOLOZ, of Milwaukee, in the county of Milwaukee and State of Wisconsin, have invented certain new and useful Improvements in Spiral Conveyers, of which the following is a specification.

My invention relates to reversible conveyers; and it consists in providing the conveyer-flight with a yoke by which it is secured to the shaft, and which permits the flight to be removed or inclined, as desired.

In the drawings, Figure 1 is a face view of my improved flight with its yoke, the shaft being shown in dotted lines; Fig. 2, a similar view with the yoke removed and the shaft in section; Fig. 3, a top plan view, and Fig. 4 is a side view, partly in section, of a slightly-different form; Fig. 5, a face view of the same; Figs. 6 and 7, face views, also illustrating slight modifications in the construction and attachment of the yoke.

A indicates a shaft, which may be made of any desired material and of any form in cross-section, and either hollow or solid, and B the conveyer-flight applied thereto. The flight is semi-elliptical, and is formed with a seat for the reception of the shaft, and on each side of this seat is formed a boss *a*, which, as shown in Fig. 2, is perforated, notched, or recessed to receive the bent ends of the yoke C when a detachable yoke is used. Just above the center of the seat formed in the flight for the shaft, on each side or face, the flight is formed with a laterally-extending arm *b*, which projects outward from the face of the flight, as shown in Fig. 3. The under face of each of these arms *b* is curved slightly and their outer ends project downward, so that when the flight is placed upon the shaft in an oblique position the under faces of the arms will bear upon the shaft throughout their length, as clearly shown in Figs. 2 and 4. The yoke C may be made of cast-iron, wire, or any other suitable material, and passes beneath the shaft, as shown in Figs. 1 and 3, the ends of the yoke being bent laterally to enter the perforations in the bosses *a* of the flight. The yoke is provided with a set-screw *c*, which passes through the yoke and bears against the shaft, as shown in Fig. 1, and as

the screw is turned up against the shaft, acting through the yoke, it holds the flight securely in position upon the shaft. By loosening the screw *c* and removing the yoke the flight may be removed and placed in the position indicated in dotted lines in Fig. 3, and the conveyer thereby changed from a right-hand to a left-hand conveyer, and vice versa.

Instead of perforating the flight to receive the ends of the yoke it may be provided with sockets *d* in one face, as shown in Figs. 4 and 5; to receive the ends of the yoke, and it will also be seen that instead of a screw a wedge *e* may be employed to tighten the yoke and draw the flight down upon the shaft.

In Fig. 6 the flight is provided with sockets *f*, which are threaded to receive screws *g*, the latter passing through the flattened or enlarged ends of the yoke; but in Fig. 7, instead of using two screws *g*, I employ only one and hinge the yoke at one end to the flight.

In using the term "yoke" I do not wish to be understood as limiting myself to any of the particular forms of yoke shown in Figs. 1 to 7, inclusive.

It will be seen that by my construction I am enabled to change the inclination of any particular flight, or any number of them, and thus make the conveyer right or left hand, or partly right and partly left.

I am aware that it has been proposed to provide a conveyer-flight with a seat for the shaft and with a screw-bolt to pass through the shaft; and I am also aware that it has been proposed to rivet a closed loop or frame to a flight and pivot said frame to a shaft. The first of these plans is objectionable for the reason that it requires the drilling of the shaft, and unless a heavy and large shaft is employed considerably weakens it, while the second is not desirable because of the great number of parts, and because, also, like the first plan, the flights have to be applied at predetermined points. Under my plan it is not necessary to weaken the shaft by drilling it, nor is it necessary that the flight be applied at any particular point upon the shaft.

Having thus described my invention, what I claim is—

1. In a spiral conveyer, the combination,

with an imperforate shaft, of a flight provided with an elongated seat in its edge of such form as to permit its lateral application to the shaft, and a fastening device, all constructed substantially as shown, whereby the flight may be moved lengthwise upon the shaft, and also made to incline in one or the other direction, as desired.

2. In combination with a shaft, a flight provided with a seat to fit upon the shaft, an arm projecting laterally from the flight to bear upon the shaft at one side of its center, and a yoke detachably secured to the shaft and provided with a device, substantially such as shown, for securing the flight in position upon the shaft.

3. In combination with a shaft A, a flight B, provided with a seat to fit upon the shaft, arms *b b*, projecting laterally from opposite faces of the flight, a yoke C, detachably secured to the flight approximately at right angles to the arms *b b*, and a device, substan-

tially such as shown, for securing the flight in position.

4. In combination with a shaft, a flight provided with a seat to receive the shaft, and with lateral arms *b b*, curved on their under faces substantially as shown, a yoke secured to the flight and bearing upon the shaft at the side opposite the flight, and a set-screw for holding the flight in place.

5. In a spiral conveyer, the combination, with an imperforate shaft, of a flight having a concave seat in its inner edge to fit upon the shaft, a yoke secured to the flight and extending upon that side of the shaft opposite to the flight, and a set-screw, or its described equivalent, carried by the yoke and serving to hold the flight in position.

HANS BIRKHOLZ.

Witnesses:

OTTO EWERT ROSWALL,
CHARLES WALDO.