

INTERNATIONAL APPLICATION PUBLISHED UNDER THE PATENT COOPERATION TREATY (PCT)

<p>(51) International Patent Classification ⁶ : B60R 1/12</p>	<p>A1</p>	<p>(11) International Publication Number: WO 99/37504 (43) International Publication Date: 29 July 1999 (29.07.99)</p>
<p>(21) International Application Number: PCT/US99/01224 (22) International Filing Date: 22 January 1999 (22.01.99) (30) Priority Data: 60/072,152 22 January 1998 (22.01.98) US (71) Applicant: MAGNA MIRROR SYSTEMS INC. [US/US]; 3151 Bancroft Avenue, Alto, MI 49302 (US). (72) Inventors: BODDY, Ian; 3447 Lake Crest Court, Ada, MI 49301 (US). JANOWICZ, Jeffrey; 3550 Pheasant Run #6, Ann Arbor, MI 48108 (US). BRINCHEK, Robert; 25646 Ingleside Drive, Southfield, MI 48034 (US). (74) Agents: LIPPITT, Raymond et al.; Cushman, Darby & Cushman, Intellectual Property Group, Pillsbury Madison & Sutro LLP, East Tower, 9th floor, 1100 New York Avenue, N.W., Washington, DC 20005-3918 (US).</p>		<p>(81) Designated States: AL, AM, AT, AU, AZ, BA, BB, BG, BR, BY, CA, CH, CN, CU, CZ, DE, DK, EE, ES, FI, GB, GD, GE, GH, GM, HR, HU, ID, IL, IN, IS, JP, KE, KG, KP, KR, KZ, LC, LK, LR, LS, LT, LU, LV, MD, MG, MK, MN, MW, MX, NO, NZ, PL, PT, RO, RU, SD, SE, SG, SI, SK, SL, TJ, TM, TR, TT, UA, UG, UZ, VN, YU, ZW, ARIPO patent (GH, GM, KE, LS, MW, SD, SZ, UG, ZW), Eurasian patent (AM, AZ, BY, KG, KZ, MD, RU, TJ, TM), European patent (AT, BE, CH, CY, DE, DK, ES, FI, FR, GB, GR, IE, IT, LU, MC, NL, PT, SE), OAPI patent (BF, BJ, CF, CG, CI, CM, GA, GN, GW, ML, MR, NE, SN, TD, TG).</p> <p>Published <i>With international search report.</i></p>

(54) Title: SINGLE PIVOT MIRROR ASSEMBLY WITH SECURITY LIGHT

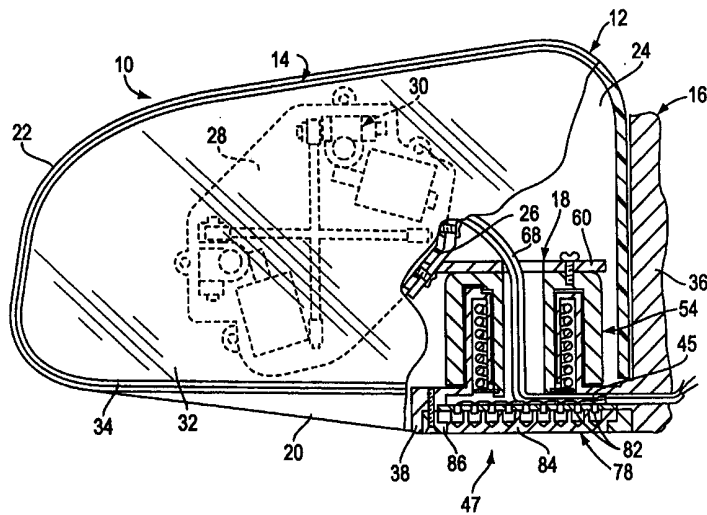

(57) Abstract

The present invention relates to an exterior vehicle mirror assembly. The mirror comprises a housing with an electrically powered adjusting mechanism mounted therein, and a support structure to be fixed to the vehicle exterior. The housing is pivotally mounted to the support structure and both the housing and support structure provide structure cooperating to define an indexing pivot assembly. The support structure has a wire receiving passage formed therein and the housing has a wire passage access opening. The access opening provides access to the passage to facilitate passing electroconductive wire through the passage so as to allow the adjusting mechanism to be connected to an electric power source and a control signal source within the vehicle. A lighting assembly is constructed and arranged to be mounted to the support structure so as to close the wire access opening after an installer has passed the wiring through the wire receiving passage. The lighting assembly has light emitting elements operable to emit light therefrom and to be operatively connected to the remote signal receiver of the vehicle such that operation of a remote transmitter will signal the receiver to cause the light emitting elements to emit light generally downwardly from the support structure towards the ground.

FOR THE PURPOSES OF INFORMATION ONLY

Codes used to identify States party to the PCT on the front pages of pamphlets publishing international applications under the PCT.

AL	Albania	ES	Spain	LS	Lesotho	SI	Slovenia
AM	Armenia	FI	Finland	LT	Lithuania	SK	Slovakia
AT	Austria	FR	France	LU	Luxembourg	SN	Senegal
AU	Australia	GA	Gabon	LV	Latvia	SZ	Swaziland
AZ	Azerbaijan	GB	United Kingdom	MC	Monaco	TD	Chad
BA	Bosnia and Herzegovina	GE	Georgia	MD	Republic of Moldova	TG	Togo
BB	Barbados	GH	Ghana	MG	Madagascar	TJ	Tajikistan
BE	Belgium	GN	Guinea	MK	The former Yugoslav Republic of Macedonia	TM	Turkmenistan
BF	Burkina Faso	GR	Greece	ML	Mali	TR	Turkey
BG	Bulgaria	HU	Hungary	MN	Mongolia	TT	Trinidad and Tobago
BJ	Benin	IE	Ireland	MR	Mauritania	UA	Ukraine
BR	Brazil	IL	Israel	MW	Malawi	UG	Uganda
BY	Belarus	IS	Iceland	MX	Mexico	US	United States of America
CA	Canada	IT	Italy	NE	Niger	UZ	Uzbekistan
CF	Central African Republic	JP	Japan	NL	Netherlands	VN	Viet Nam
CG	Congo	KE	Kenya	NO	Norway	YU	Yugoslavia
CH	Switzerland	KG	Kyrgyzstan	NZ	New Zealand	ZW	Zimbabwe
CI	Côte d'Ivoire	KP	Democratic People's Republic of Korea	PL	Poland		
CM	Cameroon	KR	Republic of Korea	PT	Portugal		
CN	China	KZ	Kazakstan	RO	Romania		
CU	Cuba	LC	Saint Lucia	RU	Russian Federation		
CZ	Czech Republic	LI	Liechtenstein	SD	Sudan		
DE	Germany	LK	Sri Lanka	SE	Sweden		
DK	Denmark	LR	Liberia	SG	Singapore		
EE	Estonia						

SINGLE PIVOT MIRROR ASSEMBLY WITH SECURITY LIGHT

Field of the Invention

5 The present invention relates to a single pivot mirror assembly with a security light for installation on exterior of a motor vehicle.

Background of the Invention

10 Various U.S. Patents have disclosed exterior vehicle mirror assemblies which incorporate a downwardly facing security light for providing a lighted area adjacent to the vehicle. The light is actuated by a remote transmitter that typically carried by the vehicle driver to remotely lock and unlock the doors and/or remotely start the engine. These lights are commonly called "puddle lamps" because light on the ground has the appearance of a puddle. Examples of such assemblies are shown in U.S. Patent Nos. 5,823,654, 5,699,704,
15 5,669,699, 5,497,306, 5,497,305 and 5,371,659 and German Patent Application. No. 3635471.

 The problem with these known mirror assemblies and is that the light emitting components thereof are not readily adaptable for use in existing mirror assemblies. Specifically, the housing mirror assemblies disclosed in these patents are specially formed
20 to accommodate the mounting of a light emitting component and have a larger forwardly facing profile than they would without the light emitting components. The larger profile results in increased wind resistance and require new tooling to form the housing because the light emitting components are not readily adaptable for existing mirror housings.

25 Summary of the Invention

 It is therefore an object of the present invention to provide a mirror assembly having a lighting assembly incorporated therein which is otherwise similar to like mirror assemblies without such a lighting assembly. Specifically, it is an object of the present invention to provide such a lighting assembly in a single-pivot mirror assembly.

30 To achieve this object, the present invention provides a single pivot mirror assembly for installation on the exterior of a motor vehicle. The mirror assembly comprises a mirror

housing and an electrically powered mirror adjusting mechanism mounted within the interior of the housing. Electroconductive wiring operatively connects the adjusting mechanism to an electric power supply source and a control signal source within the vehicle. A support structure is constructed and arranged to be fixedly mounted to the motor
5 vehicle exterior.

A reflective mirror positioned to face generally rearwardly with respect to the vehicle when the support structure is fixedly mounted with the vehicle exterior. The adjusting mechanism selectively positions the mirror relative to the housing in response to a control signal transmitted from the control signal source through the electroconductive
10 wiring. The mirror housing is pivotally mounted to the support structure for pivotal movement about a generally vertically extending pivot axis with the housing and the support structure providing structure cooperating to define an indexing pivot assembly. The indexing pivot assembly provides cooperating structures engaged with one another to yieldably maintain the housing in a fixed angular position with respect to the pivot axis
15 absent an impact force of a sufficient magnitude being applied to the housing. The cooperating structures will yieldingly move and disengage from one another as a result of the impact force of sufficient magnitude being applied to the housing so as to allow the housing to pivot in the direction of the applied impact force.

The support structure has a wire passage access opening positioned and configured
20 to face generally downwardly when the mirror assembly is mounted to the vehicle exterior. The access opening provides access to the wire receiving passage to facilitate passing the wiring through the wire receiving passage so as to allow the wiring to be connected between the adjusting mechanism and the electric power supply source and the control signal source when the access opening is open. A lighting assembly is constructed and arranged to be
25 mounted to the support structure so as to close the wire access opening after an installer has passed the wiring between through the receiving passage. The lighting assembly has light emitting elements operable to emit light therefrom and to be operatively connected to the remote signal receiver of the vehicle such that, when the support structure is fixedly
30 mounted to the vehicle exterior, operation of the remote transmitter will signal the remote receiver to cause the light emitting elements to emit light generally downwardly from the support structure towards the ground so as to provide a lighted security zone adjacent to the

vehicle.

The mirror assembly of the present invention provides the advantages of incorporating a lighting assembly into an existing mirror assembly which has been heretofore provided with an opening for accessing the pivot assembly and the wire receiving passage. In particular, the lighting assembly can be provided without changing the construction of either the support structure or the housing of an existing mirror assembly, thus saving the costs of providing new tooling for mirror assembly components which will accommodate a lighting assembly, such as those in the prior art.

10 **Brief Description of the Drawings**

Figure 1 is an elevational view of a vehicle mirror assembly embodying the principles of the present invention as viewed by looking forwardly at the left-hand side of the vehicle with the mirror assembly in its operative position, the mirror assembly being shown partly in section for purposes of clearer illustration;

15 Figure 2 is a schematic view illustrating the electrical circuit for turning the mirror light on and moving the mirror;

Figure 3 is an enlarged cross-sectional view of the material shown in Figure 1 in cross-section, with LEDs as the light emitting elements;

Figure 4 is a fragmentary bottom plan view of the structure shown in Figure 3; and

20 Figure 5 is a perspective view of the support structure of the mirror assembly shown in Figure 1;

Figure 6 is an enlarged cross-sectional view similar to Figure 3, with incandescent bulbs as the light emitting elements.

25 **Detailed Description of the Preferred Embodiment of the Invention**

Figure 1 shows a vehicle mirror assembly, generally indicated at 10, which embodies the principles of the present invention. The vehicle mirror assembly 10 includes, in general, a molded plastic housing, generally indicated at 12, a mirror unit, generally indicated at 14 and mounted on the housing 12, and a support structure, generally indicated at 16. The support structure 16 is constructed and arranged to be fixedly mounted on a vehicle exterior, and specifically a front door thereof, so that the mirror unit 14 serves as a

rear view mirror for the driver of the vehicle. A spring-biased indexing pivot assembly, generally indicated at 18, is defined between the support structure 16 and the housing 12 and is constructed and arranged to enable the housing 12 to be pivoted with respect to the support structure about an upright axis from an operative position thereof in either direction in response to an unwanted impact blow applied in either direction thereto.

The construction of the housing 12 is dependent upon whether the mirror assembly 10 is to be attached to a passenger car type automotive vehicle or other type of automotive vehicle, such as a truck or the like. In the passenger car exemplary embodiment shown, the housing 12 includes a molded plastic shell structure 20 providing a rearwardly disposed periphery 22 extending in surrounding relation to the mirror unit 14 and a front wall 24 which bulges forwardly in covering relation to the mirror unit 14.

The housing 12, as shown, also includes a fixed casing member 26 which is fixed to the central portion of the front housing wall 24 or it may be molded as an integral part thereof. The fixed casing member 26 is constructed and arranged to mate with a cooperating casing member 28 which is detachably fixed thereto. Carried by and within the casing members 26 and 28 is a power-operated adjusting mechanism, generally indicated at 30, which extends from the casing member 28 to the mirror unit 14. The adjusting mechanism 30 is constructed and arranged to move the mirror unit 14 into any one of a multiplicity of adjusted positions with respect to the housing 12. As shown, the adjusting mechanism 30 is constructed in accordance with the principles enunciated in commonly assigned U.S. Patent No. 5,467,230, the disclosure of which is hereby incorporated by reference into the present specification. It will be understood that other known power-operated mechanisms may be utilized, as, for example, the more conventional mechanism as disclosed in U.S. Patent No. 4,915,493, the disclosure of which is hereby incorporated by reference into the present specification.

In the embodiment shown, the mirror unit 14 consists of a mirror 32 and a mirror holder 34 the forward portion of which includes mounting elements for the adjusting mechanism 30.

In the preferred embodiment shown, the support structure 16 comprises a rigid structure including a door-mounting portion 36 which is suitably fixed to the vehicle front door. If desired, the door-mounting portion 36 can be covered by a cover member (not

shown) in accordance with the teachings of commonly assigned U.S. Patent No. 5,477,391, the disclosure of which is hereby incorporated by reference into the present specification.

The rigid support structure 16 also includes a housing support portion 38 which extends laterally outwardly from the door-mounting portion 36. The housing support portion 38 is formed with a downwardly facing generally circular recess 40 in its lower section. The peripheral wall of the housing support portion 38 which defines the periphery of the recess 40 is formed with an intermediate shoulder 42 and a lower shoulder 44. The support structure 16 further includes a wire receiving passage 45 extending through the door mounting portion 36 and into the housing support portion 38. The door mounting portion 36 has an opening (not shown) which allows wiring to be extended between the vehicle body interior and the wire receiving passage 45. As can be seen from the Figures, the wire receiving passage 45 communicates with the housing 12 interior. The circular recess 40 defines a wire passage access opening 47 which provides access to the wire receiving passage 45.

The housing support portion 38 also includes an integral upstanding outer cylindrical portion 46, an annular flange portion 48 extending inwardly from the upper edge of the outer cylindrical portion 46, and an inner cylindrical portion 50 extending downwardly from the inner edge of the flange portion 48. The outer and inner cylindrical portions 46 and 50 and the connecting flange 48 constitute a part of the spring-biased indexing pivot assembly 18 of the present subject matter.

Mounted within the central opening defined by the inner cylindrical portion 50 which communicates with the access opening is a cylindrical core portion 52 of a mounting member, generally indicated at 54, which forms a part of the spring-biased indexing pivot assembly 18. The mounting member 54 includes an integral annular flange portion 56 extending radially outwardly from the upper end of the cylindrical core portion 52 and an integral outer cylindrical portion 58 extending downwardly from the outer end of the flange portion 56. The mounting member 54 is, in turn, connected with the housing 12 through a bracket 60 which is suitably fixed both to the mounting member 54, as by bolts 62 or the like, and to the fixed casing member 26, as by bolts 64 or the like. The bracket 60 includes an opening 66 which communicates with the opening defined by the core portion 52 of the mounting member 54 and the wire receiving passage 45 to enable an electric wire 68 to be

extended to or from the power-operated adjusting mechanism 30 to supply electrical power and control signals to affect the movement of the mirror unit 14.

A coil spring 70 mounted within the annular space between the outer and inner cylindrical portions 46 and 50 of the rigid support structure 16. The upper end of the coil spring 70 engages the flange portion 48 and the lower end engages a generally radially extending flange portion in the form of an expandable C-washer 72 mounted within an annular groove in the lower periphery of the core portion 52.

The coil spring 70 functions to bias the flange portion 56 of the mounting member 54 into engagement with the flange portion 48 of the rigid support structure 16. The C-washer 72 is spaced below the lower edge of the inner cylindrical portion 50 of the rigid support structure 16 so as to allow the mounting member 54 and housing 12 fixed thereto to be moved upwardly against the spring bias a limited amount. This limited amount of movement is provided to accommodate the indexing function of the pivot assembly 18.

As best shown in Figure 5, the indexing function is accomplished by three annularly spaced raised indexing projections 74 having ramped opposite ends formed on the upper surface of the flange portion 48 of the rigid support structure 18 and a series of cooperating recesses 76 formed in the lower surface of the flange portion 56 of the mounting member 54. The three projections 74 seat within cooperating recesses 76 when the mounting member 54 and housing 12 are in an operative position extending laterally outwardly from the door of the vehicle. The rotational mounting of the mounting member 54 on the outer and inner cylindrical portions 46 and 50 of the rigid support structure 16 enables the housing 12 to be manually moved about the axis provided by the outer and inner cylindrical portions 46 and 50 of the rigid support structure 16 in either direction away from the operative position thereof. However, the action of the spring 70 and the raised projections 74 within the recesses 76 provides a yielding resistance to such movement. After a small amount of movement, housing 12 is displaced upwardly and the upper surfaces of the projections 74 ride on the lower surface of the flange portion 56 between the recesses 76. The spring 70 applies a biasing force to yieldingly resist this upward movement. This yielding movement in either direction will occur when unwanted impact blows of a sufficient magnitude in either direction are delivered to the housing 12. Such yielding movement prevents damage which would otherwise occur if unwanted impact blows were

delivered to the housing without the yielding movement capability.

If desired, the recesses 76 can be positioned to index the housing in a folded back position.

In a broad sense, the raised projections 74 and the recessed surfaces 76 may be considered cooperating structures which are normally engaged with one another to yieldingly maintain the housing 12 in a fixed angular position. When an impact force of sufficient magnitude is applied to the housing 12, the cooperating structures will yieldingly move and disengage from one another to allow the housing 12 to pivot in the direction of the force. Other arrangements may be used to provide this indexed pivoting effect. Further, a powered indexing control system, such as the one disclosed in commonly owned U.S. Patent No. 5,703,732, the entirety of which is hereby incorporated into the present application by reference, may be used. When a power-operated system is used, the wiring therefor may be passed through wire receiving passage 45 to the vehicle power source.

In accordance with the principles of the present invention, a light assembly, generally indicated at 78, is mounted within the recess 40. The light assembly 78 includes a circuit board 80 on which is mounted an array of light emitting elements in the form of light-emitting diodes (LEDs) 82. As shown, the circuit board 80 is mounted within the recess 40 in engagement with the intermediate shoulder 42 and a lens structure 84 is mounted below the circuit board 80 in cooperation with the downwardly extending LEDs 82 mounted thereon. The lens structure 84 and circuit board 80 are detachably mounted within the recess 40 by a suitable rim 86 which is suitably fixed to the rigid support structure 18 as by bolts 88 or the like. The rim 86 can be snap-fitted or secured in any other well-known fashion to the rigid structure portion 38.

A number of electrical wires 90 for energizing and controlling the light assembly 78, like the electrical wires 68, extend through the wire receiving passageway 45 in the rigid support structure 18.

The light assembly 78, when turned on, provides a security light for an operator of the vehicle which light shines downwardly from the mirror assembly 10 to provide a lighted security zone surrounding the lower end of the driver's door of the vehicle. The light thus provides an assist for the operator in entering the vehicle from the exterior thereof. To facilitate the turning on of the light assembly 78 from the exterior of the vehicle, the present

invention contemplates the use of a portable battery-operated radio frequency transmitter 94 of the type that are presently provided as part of the key assembly to vehicle car owners. The conventional transmitter 94, when actuated, transmits a radio signal which is received by a receiver 96 within the vehicle which is connected in the vehicle battery circuit. The vehicle battery circuit in which the receiver is connected can control the interior lights and power locks for the doors as well as other instrumentalities which are well known. In accordance with the present invention, the signal from the RF receiver is connected to the circuit board 80 to energize the LED's 82 and produce a light which shines downwardly through the lens structure 84. As previously indicated, the mirror control wires can be associated with the control wires for the light assembly so as to extend through the door and the door mounting portion 36 of the mirror assembly 10 to the light assembly 78 and power-operated adjusting mechanism 30. It will be understood that the de-energizing of the light assembly 78 can be controlled from the circuit within the vehicle. The details of an exemplary circuit can be secured by reviewing the disclosure of U.S. Patent No. 5,371,659, the disclosure of which is hereby incorporated by reference into the present specification.

Figure 6 shows an alternative embodiment of the present invention. Because many of the structural components are the same between this alternative embodiment and the previous embodiment, the same reference numerals will denote substantially identical structures and components.

The main difference between the embodiment of Figure 6 and the previous embodiment is that the lighting assembly 100 of the alternative embodiment utilizes a plurality of common incandescent bulbs 102 in place of LEDs 82. The circuit board 104 has sockets 106 for mounting the bulbs 102. The bulbs 102 can be either threadingly engaged or soldered to the sockets 104. A thin lens structure 108 is mounted in place and has a plurality of indentations 110 for receiving the ends of the bulbs 102. The positioning of the bulb ends within the indentations helps reduce the overall thickness of the lighting assembly 100.

Incandescent bulbs 102 are common bulbs similar to those found in flashlights. The use of incandescent bulbs 102 is preferred over LEDs 82 because incandescent bulbs 102 can be purchased at a fraction of the cost of LEDs. Thus, the use of incandescent bulbs 102 helps keep the overall cost of the mirror 10 assembly down.

A significant advantage of the present subject matter resides in the construction of the light assembly 78, 100 and its mounting within the mirror assembly 10. By utilizing a circuit board 80, 104 with an array of light emitting elements and a relatively thin cooperating lens structure 84, it becomes possible to essentially provide the light assembly
5 78 within the confines of the support structures heretofore provided without a light assembly. Single pivot mirror assemblies of the type herein described have been provided without embodying a light assembly in much the same construction as that presently described where the opening 47 is provided for facilitating connecting the wiring to and from the adjusting mechanism for moving the mirror unit and is covered by a snap-in cover.
10 To provide the light function without substantially changing the configuration of the mirror assembly 10 is a highly desirable function because of the wind resistance that would be added if an increase in the overall periphery of the mirror assembly 10 were to be required.

It can thus be seen that the objects of the present invention have been fully and effectively accomplished. It will be understood that the foregoing preferred embodiments
15 have been provided to illustrate the functional and structural principles of the present invention and are not intended to be limiting. To the contrary, the present invention is intended to encompass all modifications, substitution, and alternations within the spirit and scope of the appended claims.

WHAT IS CLAIMED IS:

1. A single pivot mirror assembly for installation on the exterior of a motor vehicle having a remote signal receiver to be used in conjunction with a remote transmitter carried by a vehicle operator, the remote receiver operating vehicle door locks or starting the vehicle engine in response to operation of the transmitter, said assembly comprising:
- 5 a mirror housing;
- an electrically powered mirror adjusting mechanism mounted within the interior of said housing;
- 10 electroconductive wiring adapted to be operatively connected between said adjusting mechanism and an electric power supply source and a control signal source within the vehicle;
- a support structure constructed and arranged to be fixedly mounted to the motor vehicle exterior proximate of driver or passenger door;
- 15 a reflective mirror positioned to face generally rearwardly with respect to the vehicle so as to reflect objects located rearwardly of the vehicle into the passenger compartment of the vehicle when said support structure is fixedly mounted with the vehicle exterior, said adjusting mechanism being constructed and arranged to selectively position said mirror relative to said housing in response to a control signal transmitted from the control signal source through said electroconductive wiring;
- 20 said mirror housing being pivotally mounted to said support structure for pivotal movement about a generally vertically extending pivot axis, said housing and said support structure providing structure cooperating to define an indexing pivot assembly;
- said indexing pivot assembly providing cooperating structures engaged with one another to yieldably maintain said housing in a fixed angular position with respect to said pivot axis absent an impact force of a sufficient magnitude being applied to said housing, said cooperating structures being constructed and arranged to yieldingly move and disengage from one another as a result of the impact force of sufficient magnitude being applied to said housing so as to allow said housing to pivot in the direction of the applied impact force;
- 25
- 30 said support structure having a wire passage access opening positioned and configured to face generally downwardly when said mirror assembly is mounted to the

vehicle exterior, said access opening being positioned and configured to provide access to said wire receiving passage so as to facilitate passing said wiring through said wire receiving passage so as to allow said wiring to be connected between said adjusting mechanism and the electric power supply source and the control signal source when said
5 access opening is open;

a lighting assembly constructed and arranged to be mounted to said support structure so as to close said wire access opening after an installer has passed said wiring through said receiving passage, said lighting assembly having light emitting elements operable to emit light therefrom and to be operatively connected to the remote signal
10 receiver of the vehicle when said support structure is fixedly mounted to the vehicle exterior such that operation of the remote transmitter will signal the remote receiver to cause said light emitting elements to emit light generally downwardly from said support structure towards the ground so as to provide a lighted security zone adjacent to the vehicle door.

15 2. A single pivot mirror assembly according to claim 1, wherein said cooperating structures of said indexing pivot assembly comprise a plurality of raised projections provided on said support structure and said a plurality of recessed surfaces provided on said housing.

20 3. A single pivot mirror assembly according to claim 2, wherein said indexing pivot assembly comprises an inner cylindrical portion provided on said support structure and an inner cylindrical portion provided on said housing;

said inner cylindrical portion of said support structure having a flange portion extending generally radially outwardly therefrom, said raised projections being
25 provided on said flange portion;

said inner cylindrical portion of said housing being received within said inner cylindrical portion of said base structure and having a flange portion extending generally radially outwardly therefrom;

said indexing pivot assembly further comprising a yieldingly deformable
30 spring engaged with both said generally radially extending flange portion and constructed and arranged to apply a biasing force to yieldingly maintain said raised projections engaged

with said recessed surfaces, said spring being constructed and arranged to yieldingly deform so as to allow said raised projections to be disengaged from said recessed surfaces when the sufficient impact force is applied to the housing.

5 4. A single pivot mirror assembly according to claim 3, wherein said inner cylindrical portion of said housing has a central opening formed therethrough and open to said wire receiving passage such that the wiring connecting said adjusting mechanism to the power source and the control signal source extends through said central opening.

10 5. A single pivot mirror assembly according to claim 4, wherein said inner cylindrical portion of said housing has another flange portion extending generally radially outwardly therefrom, said recessed surfaces being provided on said another flange portion.

15 6. A single pivot mirror assembly according to claim 5, wherein said housing has an outer cylindrical portion formed integrally with said another flange portion thereof and spaced radially outwardly from said inner cylindrical portion thereof;

 said support structure having an outer cylindrical portion formed integrally with said flange portion thereof and spaced radially outwardly from said inner cylindrical portion thereof;

20 said spring being received between the inner and outer cylindrical portions of said support structure;

 said inner and outer cylindrical portions and said flange portion of said support structure being received between the inner and outer cylindrical portions of said housing.

25

7. A single pivot mirror assembly according to claim 6, wherein said flange portion of said inner cylindrical portion said housing is an expandable washer.

30 8. A single pivot assembly according to claim 1, wherein said light assembly comprises a circuit board and a lens, said light emitting elements being mounted to said circuit board.

9. A single pivot mirror assembly according to claim 8, wherein said light emitting elements are incandescent bulbs.
10. A single pivot mirror assembly according to claim 8, wherein said light emitting
5 elements are light emitting diodes.
11. A single pivot mirror assembly according to claim 8, further comprising additional electroconductive wiring adapted to be connected between said lighting assembly and the electrical power source of the vehicle, said additional wiring extending through said wire
10 receiving passage between said lighting assembly and the electrical power source when said support structure is fixedly mounted to the vehicle exterior.

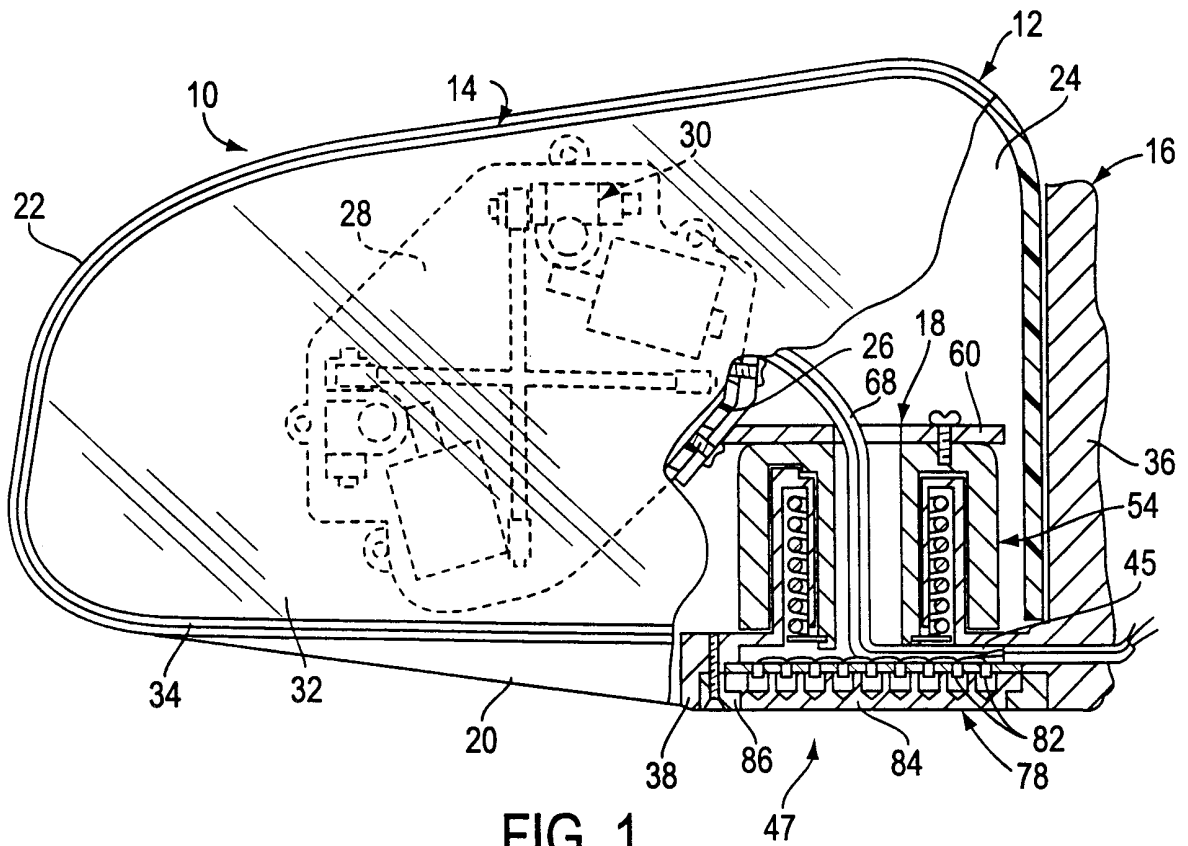

FIG. 1

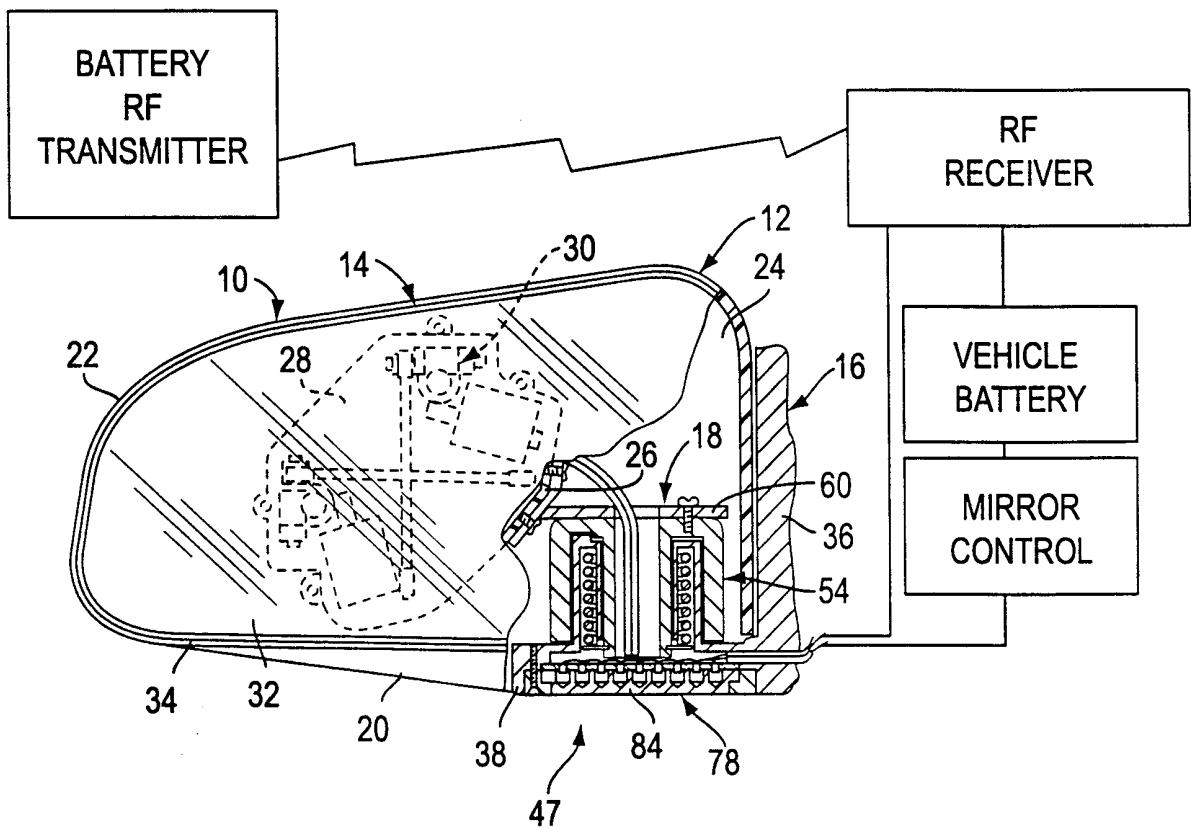

FIG. 2

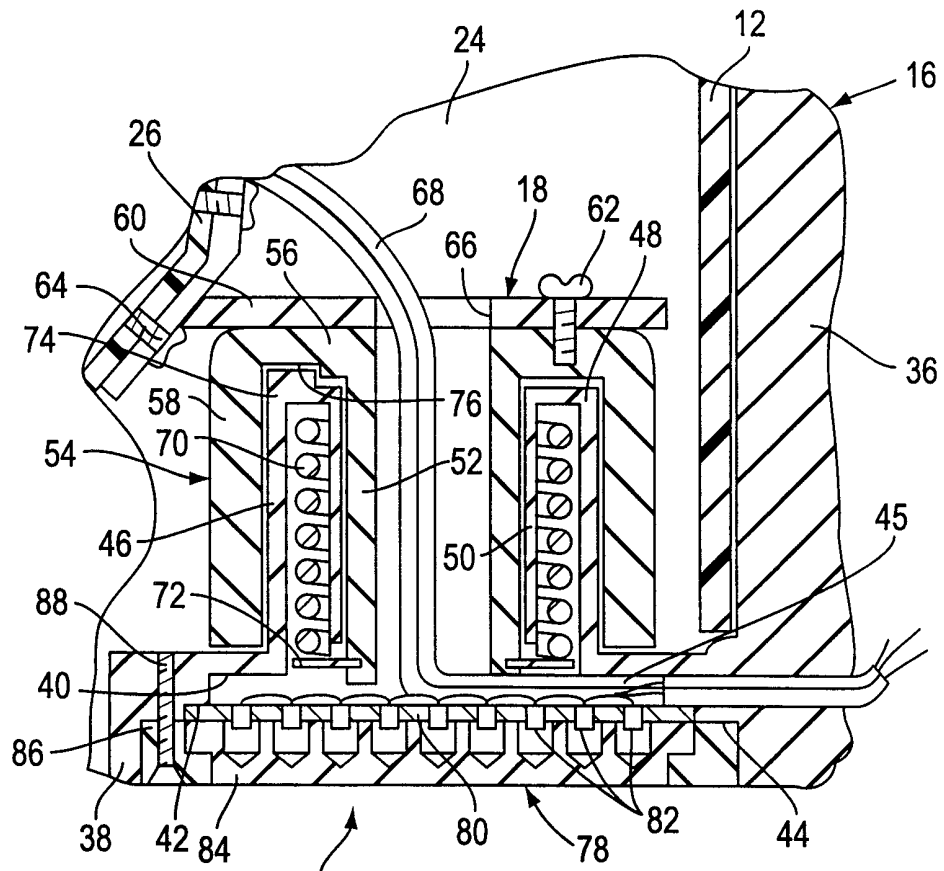

FIG. 3

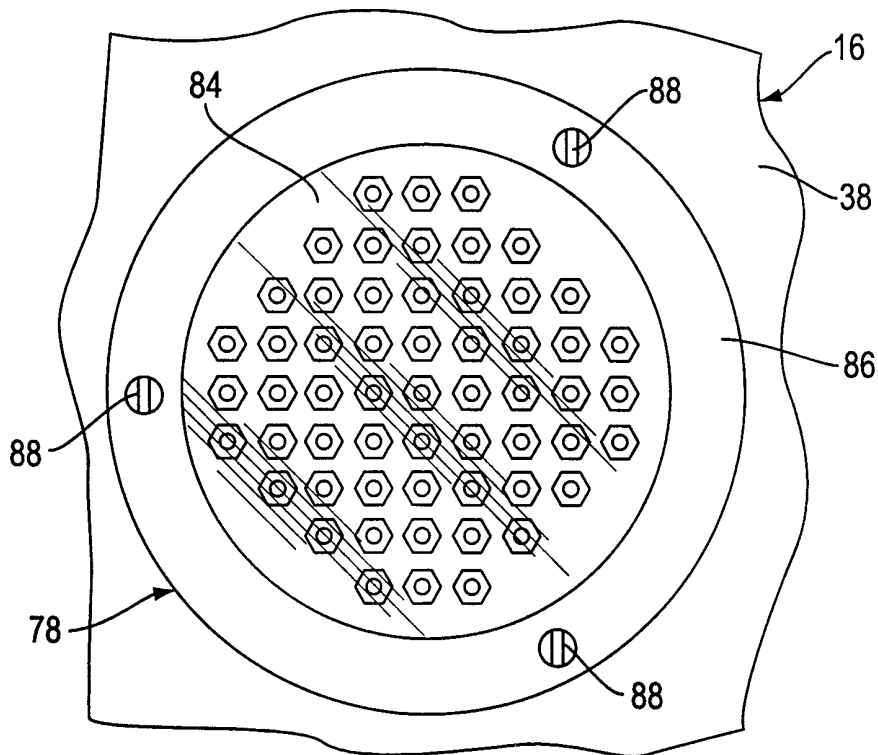

FIG. 4

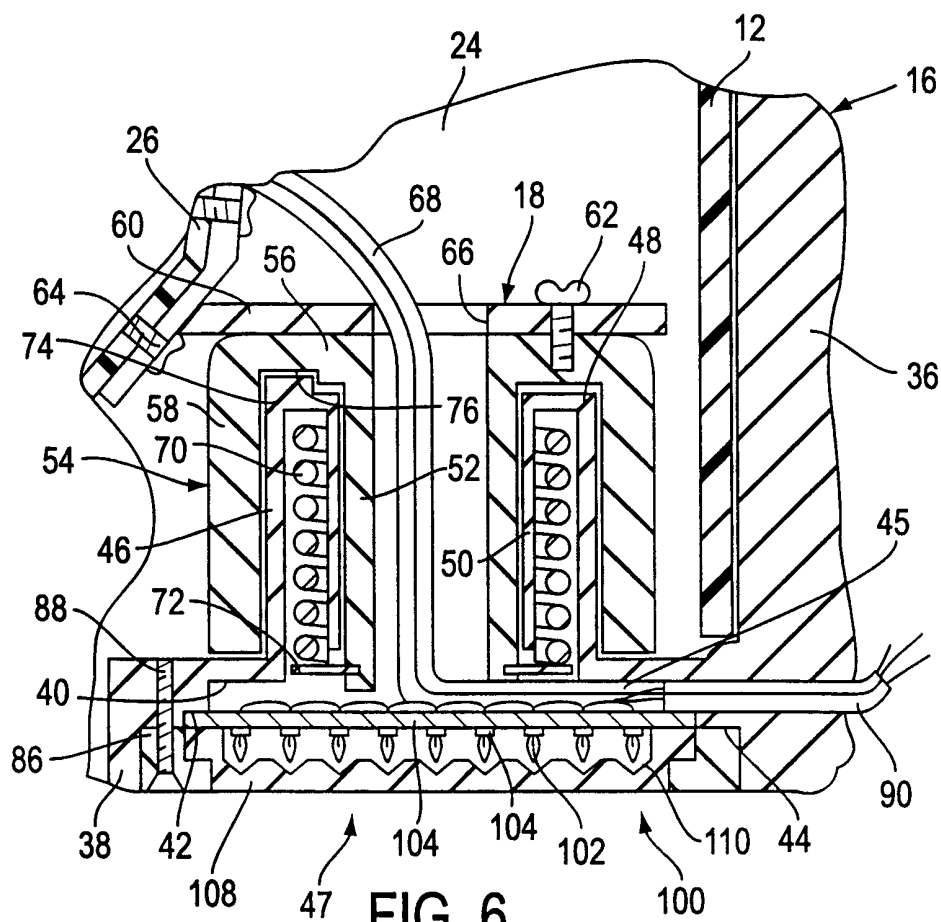

FIG. 6

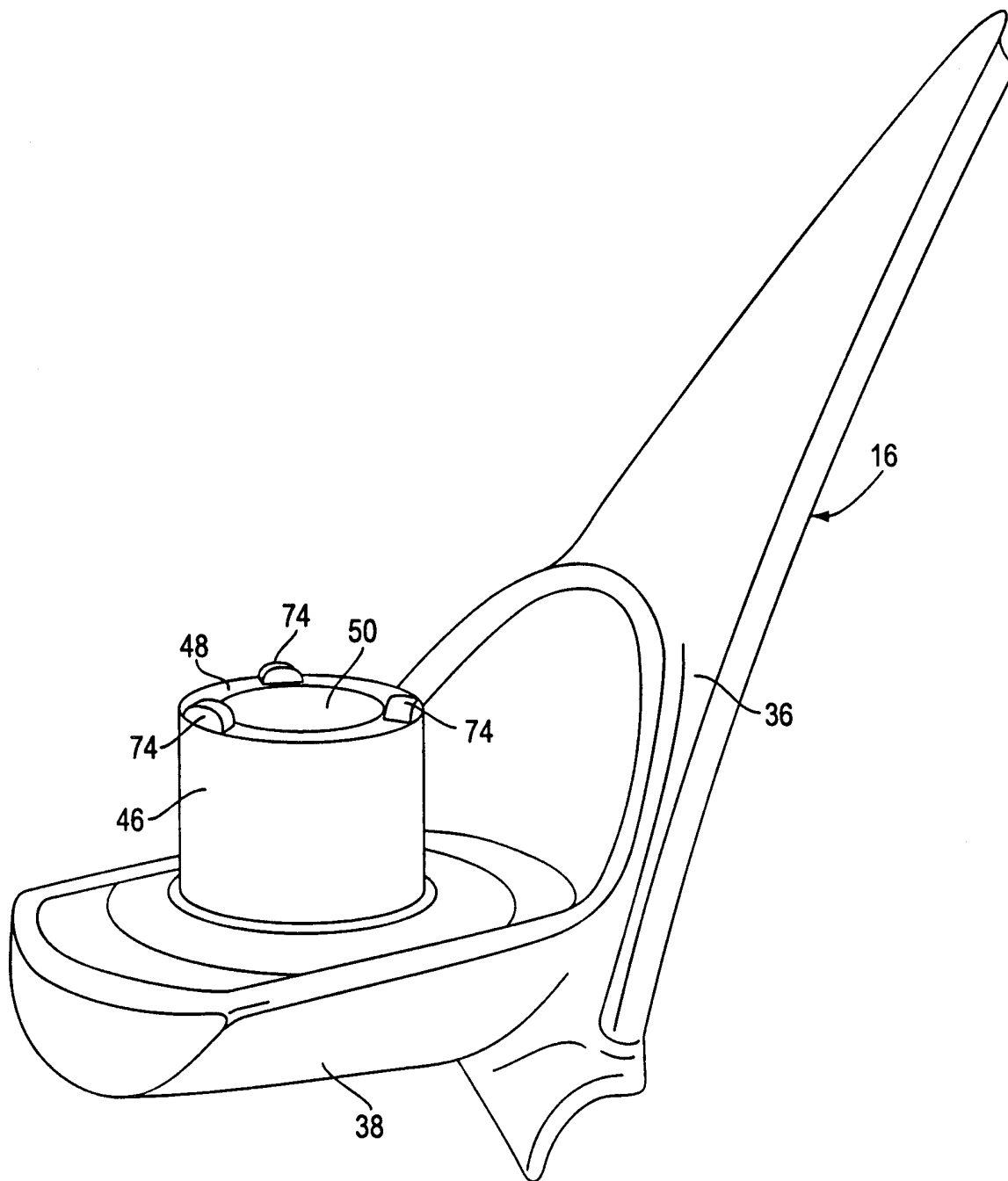

FIG. 5

INTERNATIONAL SEARCH REPORT

International Application No

PCT/US 99/01224

A. CLASSIFICATION OF SUBJECT MATTER

IPC 6 B60R1/12

According to International Patent Classification (IPC) or to both national classification and IPC

B. FIELDS SEARCHED

Minimum documentation searched (classification system followed by classification symbols)

IPC 6 B60R

Documentation searched other than minimum documentation to the extent that such documents are included in the fields searched

Electronic data base consulted during the international search (name of data base and, where practical, search terms used)

C. DOCUMENTS CONSIDERED TO BE RELEVANT

Category °	Citation of document, with indication, where appropriate, of the relevant passages	Relevant to claim No.
A	GB 2 155 876 A (TOKAI RIKI DENKI) 2 October 1985 see figure 1 -----	1

Further documents are listed in the continuation of box C.

Patent family members are listed in annex.

° Special categories of cited documents :

- "A" document defining the general state of the art which is not considered to be of particular relevance
- "E" earlier document but published on or after the international filing date
- "L" document which may throw doubts on priority claim(s) or which is cited to establish the publication date of another citation or other special reason (as specified)
- "O" document referring to an oral disclosure, use, exhibition or other means
- "P" document published prior to the international filing date but later than the priority date claimed

- "T" later document published after the international filing date or priority date and not in conflict with the application but cited to understand the principle or theory underlying the invention
- "X" document of particular relevance; the claimed invention cannot be considered novel or cannot be considered to involve an inventive step when the document is taken alone
- "Y" document of particular relevance; the claimed invention cannot be considered to involve an inventive step when the document is combined with one or more other such documents, such combination being obvious to a person skilled in the art.
- "&" document member of the same patent family

Date of the actual completion of the international search

17 March 1999

Date of mailing of the international search report

23/03/1999

Name and mailing address of the ISA

European Patent Office, P.B. 5818 Patentlaan 2
 NL - 2280 HV Rijswijk
 Tel. (+31-70) 340-2040, Tx. 31 651 epo nl,
 Fax: (+31-70) 340-3016

Authorized officer

Knops, J

INTERNATIONAL SEARCH REPORT

Information on patent family members

International Application No

PCT/US 99/01224

Patent document cited in search report	Publication date	Patent family member(s)	Publication date
GB 2155876 A	02-10-1985	JP 1603295 C	29-03-1991
		JP 2028490 B	25-06-1990
		JP 60179352 A	13-09-1985
		JP 1630494 C	26-12-1991
		JP 2056256 B	29-11-1990
		JP 61036037 A	20-02-1986
		DE 3507000 A	29-08-1985
		US 4657362 A	14-04-1987
