



INTERNATIONAL APPLICATION PUBLISHED UNDER THE PATENT COOPERATION TREATY (PCT)

(51) International Patent Classification ⁶ : H01B	A2	(11) International Publication Number: WO 98/33189 (43) International Publication Date: 30 July 1998 (30.07.98)
(21) International Application Number: PCT/US98/01814 (22) International Filing Date: 28 January 1998 (28.01.98) (30) Priority Data: 60/039,902 29 January 1997 (29.01.97) US 09/014,333 27 January 1998 (27.01.98) US (71) Applicant (for all designated States except US): SONY TRANS COM INC. [US/US]; 1833 Alton Avenue, Irvine, CA 92713 (US). (72) Inventors; and (75) Inventors/Applicants (for US only): TROXEL, Robert, V. [US/US]; 1311 Beechwood Drive, Brea, CA 92621 (US). CARDON, Jay, Edward [US/US]; P.O. Box 55603, River- side, CA 92517 (US). NINH, Loi, Quang [US/US]; 22 Cal- abria Lane, Foothill Ranch, CA 92610 (US). (74) Agents: HAVERSTOCK, Thomas, B. et al.; Haverstock & Owens LLP, Suite 420, 260 Sheridan Avenue, Palo Alto, CA 94306 (US).		(81) Designated States: AL, AM, AT, AU, AZ, BA, BB, BG, BR, BY, CA, CH, CN, CU, CZ, DE, DK, EE, ES, FI, GB, GE, GH, GM, GW, HU, ID, IL, IS, JP, KE, KG, KP, KR, KZ, LC, LK, LR, LS, LT, LU, LV, MD, MG, MK, MN, MW, MX, NO, NZ, PL, PT, RO, RU, SD, SE, SG, SI, SK, SL, TJ, TM, TR, TT, UA, UG, US, UZ, VN, YU, ZW, ARIPO patent (GH, GM, KE, LS, MW, SD, SZ, UG, ZW), Eurasian patent (AM, AZ, BY, KG, KZ, MD, RU, TJ, TM), European patent (AT, BE, CH, DE, DK, ES, FI, FR, GB, GR, IE, IT, LU, MC, NL, PT, SE), OAPI patent (BF, BJ, CF, CG, CI, CM, GA, GN, ML, MR, NE, SN, TD, TG). Published <i>Without international search report and to be republished upon receipt of that report.</i>

(54) Title: QUAD CABLE CONSTRUCTION FOR IEEE 1394 DATA TRANSMISSION

(57) Abstract

A quad cable includes four conductors arranged as two differential pairs for carrying the differential signals TPA and TPB. Preferably, the quad cable is used to transmit data signals between devices within an IEEE 1394 network. The two differential conductor pairs are included, with filler material, within a braided inner shield. A shield separator is formed outside of the braided inner shield. A braided outer shield is formed outside of the shield separator. The shield separator provides electrical isolation between the inner and outer shields. A cable jacket is formed outside of the braided outer shield to encase the cable. Each end of the cable includes a cable connector having a plurality of pins for coupling to a receiving connector. The four conductors and the inner shield are each coupled to a respective pin within each cable connector. When coupled to a receiving connector, the outer shield is coupled to a housing of the connector. Within unit electronics at the port housing the receiving connector, a capacitor is preferably coupled between the inner shield and the outer shield. Preferably, the quad cable has a length of 4.5 meters and includes 24 gauge wire for the conductors. Longer, alternate embodiments of the cable incorporate heavier gauge wire for the conductors. Preferably, DC power conductors are not included within the quad cable, but are provided within a separate cable or by each active local device. Alternatively, the DC power conductors are included beside the quad cable within an overall cable jacket.

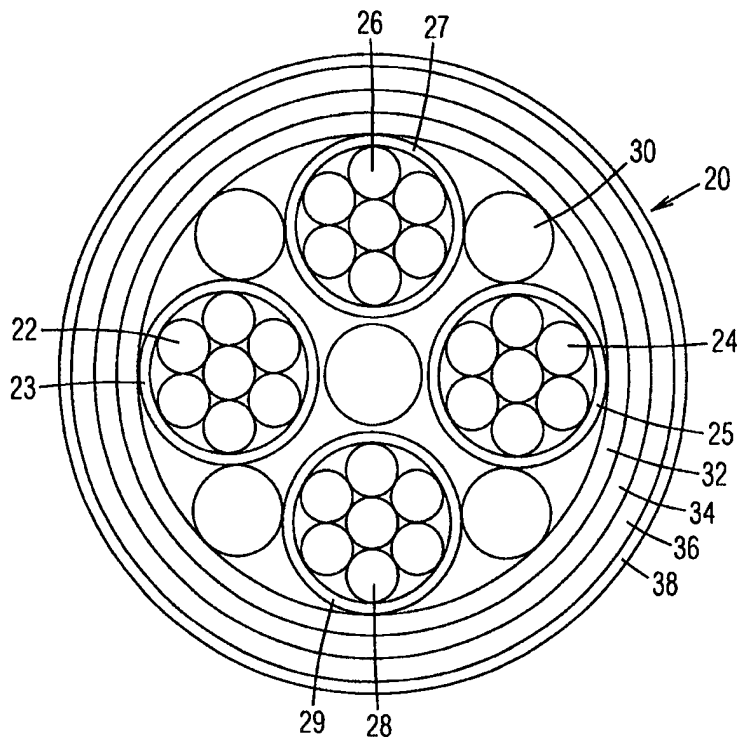

Preferably, DC power conductors are not included within the quad cable, but are provided within a separate cable or by each active local device. Alternatively, the DC power conductors are included beside the quad cable within an overall cable jacket.

FOR THE PURPOSES OF INFORMATION ONLY

Codes used to identify States party to the PCT on the front pages of pamphlets publishing international applications under the PCT.

AL	Albania	ES	Spain	LS	Lesotho	SI	Slovenia
AM	Armenia	FI	Finland	LT	Lithuania	SK	Slovakia
AT	Austria	FR	France	LU	Luxembourg	SN	Senegal
AU	Australia	GA	Gabon	LV	Latvia	SZ	Swaziland
AZ	Azerbaijan	GB	United Kingdom	MC	Monaco	TD	Chad
BA	Bosnia and Herzegovina	GE	Georgia	MD	Republic of Moldova	TG	Togo
BB	Barbados	GH	Ghana	MG	Madagascar	TJ	Tajikistan
BE	Belgium	GN	Guinea	MK	The former Yugoslav Republic of Macedonia	TM	Turkmenistan
BF	Burkina Faso	GR	Greece			TR	Turkey
BG	Bulgaria	HU	Hungary	ML	Mali	TT	Trinidad and Tobago
BJ	Benin	IE	Ireland	MN	Mongolia	UA	Ukraine
BR	Brazil	IL	Israel	MR	Mauritania	UG	Uganda
BY	Belarus	IS	Iceland	MW	Malawi	US	United States of America
CA	Canada	IT	Italy	MX	Mexico	UZ	Uzbekistan
CF	Central African Republic	JP	Japan	NE	Niger	VN	Viet Nam
CG	Congo	KE	Kenya	NL	Netherlands	YU	Yugoslavia
CH	Switzerland	KG	Kyrgyzstan	NO	Norway	ZW	Zimbabwe
CI	Côte d'Ivoire	KP	Democratic People's Republic of Korea	NZ	New Zealand		
CM	Cameroon			PL	Poland		
CN	China	KR	Republic of Korea	PT	Portugal		
CU	Cuba	KZ	Kazakstan	RO	Romania		
CZ	Czech Republic	LC	Saint Lucia	RU	Russian Federation		
DE	Germany	LI	Liechtenstein	SD	Sudan		
DK	Denmark	LK	Sri Lanka	SE	Sweden		
EE	Estonia	LR	Liberia	SG	Singapore		

**QUAD CABLE CONSTRUCTION FOR
IEEE 1394 DATA TRANSMISSION**

RELATED APPLICATIONS:

5 This application claims priority under 35 U.S.C. § 119(e) of the co-pending U.S. provisional application Serial Number 60/039,902 filed on January 29, 1997 and entitled "QUAD CABLE CONSTRUCTION FOR IEEE P1394 DATA TRANSMISSION." The provisional application Serial Number 60/039,902 filed on January 29, 1997 and entitled "QUAD CABLE CONSTRUCTION FOR IEEE P1394 DATA TRANSMISSION" is also
10 hereby incorporated by reference.

FIELD OF THE INVENTION:

 The present invention relates to the field of network cabling. More particularly, the present invention relates to the field of network cabling for use with an IEEE 1394 serial
15 bus network.

BACKGROUND OF THE INVENTION:

 The IEEE 1394 standard, "P1394 Standard For A High Performance Serial Bus," Draft 8.01v1, June 16, 1995, is an international standard for implementing an inexpensive
20 high-speed serial bus architecture which supports both asynchronous and isochronous format data transfers. The IEEE 1394 standard provides a high-speed serial bus for interconnecting digital devices thereby providing a universal I/O connection. The IEEE 1394 standard defines a digital interface for the applications thereby eliminating the need for an application to convert digital data to analog data before it is transmitted across the
25 bus. Correspondingly, a receiving application will receive digital data from the bus, not analog data, and will therefore not be required to convert analog data to digital data. An 'application' as used herein will refer to either an application or a device driver.

 The cable specified by the IEEE 1394 standard is very thin in size compared to many other cables, such as conventional co-axial cables, used to connect such devices.
30 Devices can be added and removed from an IEEE 1394 bus while the bus is active. If a device is so added or removed the bus will then automatically reconfigure itself for transmitting data between the then existing nodes. A node is considered a logical entity

with a unique address on the bus structure. Each node provides an identification ROM, a standardized set of control registers and its own address space.

5 A standard IEEE 1394 cable is illustrated in Figure 1. An IEEE 1394 network using the standard IEEE 1394 cable 10 is a differential, copper wire network, which includes two differential pairs of wires 12 and 14, carrying the differential signals TPA and TPB, respectively. As shown in Figure 1, the pairs of wires 12 and 14 are twisted together within the cable 10. The signals TPA and TPB are both low voltage, low current, bidirectional differential signals used to carry data bits or arbitration signals. The signals
10 TPA and TPB have a maximum specified amplitude of 265 mVolts. The twisted pairs of wires 12 and 14 have a relatively high impedance, specified at 110 ohms, such that minimal power is needed to drive an adequate signal across the wires 12 and 14. The standard IEEE 1394 cable 10 also includes a pair of power signals VG and VP, carried on the wires 16 and 18, respectively. The wires 16 and 18 are also twisted together within
15 the cable 10. The pair of power signals VP and VG provide the current needed by the physical layer of the serial bus to repeat signals. The wires 16 and 18 have a relatively low impedance and are specified to have a maximum power level of 60 watts.

The IEEE 1394 cable environment is a network of nodes connected by point-to-point links, including a port on each node's physical connection and the cable between
20 them. The physical topology for the cable environment of an IEEE 1394 serial bus is a non-cyclic network of multiple ports, with finite branches. The primary restriction on the cable environment is that nodes must be connected together without forming any closed loops.

The IEEE 1394 cable connects ports together on different nodes. Each port
25 includes terminators, transceivers and simple logic. A node can have multiple ports at its physical connection. The cable and ports act as bus repeaters between the nodes to simulate a single logical bus. Because each node must continuously repeat bus signals, the separate power VP wire 18 and ground VG wire 16, within the cable 10, enable the physical layer of each node to remain operational even when the local power at the node is
30 turned off. The pair of power wires 16 and 18 can even be used to power an entire node if it has modest power requirements. The signal VG carried on the wire 16 is a grounded signal. The signal VP carried on the wire 18 is powered from local power of the active

devices on the IEEE 1394 serial bus. Accordingly, at least one of the active devices must be powered by local power. Together, the signals VG and VP form a power signal which is used by the nodes.

5 A maximum cable length of 4.5 meters is specified for an IEEE 1394 cable. The cabling limitations of an IEEE 1394 serial bus are set by the timing requirements and signal waveform characteristics for transmitted signals. The default timing is set after at most two bus resets, and it is adequate for 32 cable hops, each of 4.5 meters, for a total of 144 meters. This maximum cable length is not practical in some environments in which
10 the distance between active devices is greater than 4.5 meters. One such environment is within an aircraft which can require cable lengths well over 4.5 meters.

U.S. Patent Application Serial No. 08/714,659, entitled "IEEE 1394 ACTIVE WALL DISCONNECT AND AIRCRAFT QUALIFIED CABLE" and filed on September 16, 1996, which is hereby incorporated by reference, teaches an IEEE 1394 cable having a
15 length greater than 4.5 meters. The longer cable lengths taught in this application incorporate heavier gauge wire for the two twisted data pairs 12 and 14 in order to match the performance characteristics of a standard IEEE 1394 cable and comply with the signal levels and timing requirements of the IEEE 1394 specification over the increased distance. U.S. Patent Application Serial No. 08/714,659 teaches an IEEE 1394 cable having a length
20 of 20 meters including twisted pairs of wire of 18 gauge wire and an IEEE 1394 cable having a length of 30 meters including twisted pairs of wire of 16 gauge wire. While the cables taught in U.S. Patent Application Serial No. 08/714,659 achieve longer cable lengths than 4.5 meters and still perform according to the appropriate parameters set by the IEEE 1394 specification, the cables are large in diameter, due to the heavier gauge wire
25 used to achieve the longer length and the thick dielectric material required to maintain signal characteristics. When wiring within a closed environment such as an aircraft where space taken up by the cable is a consideration, large diameter cables are disadvantageous and present problems in assembling and routing the cables. The large diameter cables also add extra weight to the aircraft.

30 What is needed is a cable for use between IEEE 1394 devices which has a length greater than 4.5 meters and a relatively small diameter and minimum weight.

SUMMARY OF THE INVENTION:

5 A quad cable includes four conductors arranged as two differential pairs for carrying the differential signals TPA and TPB. Preferably, the quad cable is used to transmit data signals between devices within an IEEE 1394 network. The two differential conductor pairs are included, with filler material, within a braided inner shield. A shield separator is formed outside of the braided inner shield. A braided outer shield is formed outside of the shield separator. The shield separator provides electrical isolation between the inner and outer shields. A cable jacket is formed outside of the braided outer shield to encase the cable. Each end of the cable includes a cable connector having a plurality of pins for coupling to a receiving connector. The four conductors and the inner shield are each coupled to a respective pin within each cable connector. When coupled to a receiving connector, the outer shield is coupled to a housing of the connector. Within unit electronics at the port housing the receiving connector, a capacitor is preferably coupled between the inner shield and the outer shield. Preferably, the quad cable has a length of 4.5 meters and includes 24 gauge wire for the conductors. Longer, alternate embodiments of the cable incorporate heavier gauge wire for the conductors. Preferably, DC power conductors are not included within the quad cable, but are provided within a separate cable or by each active local device. Alternatively, the DC power conductors are included beside the quad cable within an overall cable jacket.

BRIEF DESCRIPTION OF THE DRAWINGS:

Figure 1 illustrates a standard IEEE 1394 cable of the prior art.

25 Figure 2 illustrates a cross section of an IEEE 1394 quad cable of the preferred embodiment of the present invention.

Figure 3 illustrates a block diagram of the assembly and connection of the quad cable of the present invention.

Figure 4 illustrates a cross section of a cable of an alternate embodiment including an IEEE 1394 quad cable and DC power conductors.

DETAILED DESCRIPTION OF THE PREFERRED EMBODIMENT:

5 A quad cable of the present invention includes four conductors arranged as two differential pairs for carrying the differential signals TPA and TPB between IEEE 1394 devices. Preferably, the quad cable is used to transmit data signals between devices within an IEEE 1394 network. Alternatively, the quad cable can be used to transmit signals within an IEEE 1394 network or within another serial bus network. The two differential conductor pairs are included, with filler material, within a braided inner shield. A shield separator is formed outside of the braided inner shield. A braided outer shield is formed outside of the shield separator. The shield separator provides electrical isolation between the inner and outer shields and preferably includes an aluminum layer for improved high frequency shielding. Preferably, a no smoke, no halogen, flame retardant cable jacket is formed outside of the braided outer shield to encase the cable. Each end of the cable includes a cable connector having a plurality of pins for coupling to a receiving connector at a device or a repeater.

15 The four conductors and the inner shield are each coupled to a respective pin within the cable connectors. When the cable connector is coupled to a receiving connector, the outer shield is coupled to a housing of the connector. Within unit electronics at the port housing the receiving connector, a capacitor is preferably coupled between the inner shield and the outer shield in order to properly maintain electrical isolation between the inner and outer shields. Preferably, the quad cable has a length of 4.5 meters and includes 24 gauge wire for the conductors. Longer, alternate embodiments of the cable incorporate heavier gauge wire for the conductors. Preferably, DC power conductors are not included within the quad cable, but are provided within a separate cable or by each active local device. Alternatively, the DC power conductors are included beside the quad cable within an overall cable jacket.

20 Generally, quad cable includes four parallel conductors all enclosed within an outer shield. Quad cable is constructed such that each conductor of a differential signal pair is geometrically opposite to the other conductor in the same pair. Within the quad cable, the two differential pairs are perpendicular to one another with a common central axis. This geometric orientation of the two differential pairs within the quad cable minimizes coupling and crosstalk between the two pairs. Within the differential pairs, the differential

30

signal transmission increases achievable common-mode rejection and signal-to-noise ratio and reduces ground bounce and the effects of electro-magnetic interference.

5 A quad cable for transmitting data between devices within an IEEE 1394 serial bus network, according to the preferred embodiment of the present invention, is illustrated in Figure 2. The quad cable 20 includes two differential pairs of conductors for transmitting signals between IEEE 1394 nodes or repeaters. The conductors 22 and 24 form a first differential pair for carrying the differential signal TPA. The conductors 26 and 28 form a second differential pair for carrying the differential signal TPB. Each of the conductors 10 22, 24, 26 and 28 have an associated conductor jacket 23, 25, 27 and 29, respectively, used to enclose and encase each conductor. The filler material 30 is constructed and positioned to maintain the relative perpendicular orientation of the signal pairs. Within the preferred embodiment of the present invention, the composition and size of the filler material 30 and the conductor jackets 23, 25, 27 and 29 is appropriate to provide a 15 characteristic impedance of $110 \text{ ohms} \pm 6 \text{ ohms}$, as measured across the two conductors of each signal pair.

The two differential pairs formed from the conductors 22, 24, 26 and 28 and the filler material 30 are encased within a braided inner shield 32. A shield separator 34 is formed around the inner shield 32. An overall braided outer shield 36 is formed around 20 the shield separator 34. The shield separator 34 provides electrical isolation between the inner shield 32 and the outer shield 36 and includes an aluminum layer to provide additional high frequency shielding. This three layer shield configuration provides improved limitation of EMI emissions and susceptibility. A jacket 38 is formed around the braided outer shield 36. This jacket 38 is preferably a no smoke, no halogen, flame 25 retardant jacket 38. This no smoke, no halogen, flame retardant jacket 38 is provided in order to comply with the Federal Aviation Administration Regulation regarding the required fire protection of systems, in order to use this cable on commercial aircraft. 14 C.F.R. § 25.869 (1994).

30 Embodiments of the IEEE 1394 quad cable of the present invention have been designed to have different lengths. The cable 20 of the preferred embodiment of the present invention has a length of 4.5 meters to comply with the IEEE 1394 standard

specification. However, alternate embodiments of the cable of the present invention have longer lengths for spanning distances greater than 4.5 meters. The IEEE 1394 cable of the present invention is preferably for use on board a commercial aircraft to couple and form an IEEE 1394 serial bus network between devices which are part of an in-flight entertainment system, as taught in U.S. Patent Application Serial Number 08/714,772, filed on September 16, 1996, and entitled "Combined Digital Audio/Video On Demand And Broadcast Distribution System," which is hereby incorporated by reference. Because of the constraints of this system and of the limited space available within the aircraft, a cable having a length greater than 4.5 meters is necessary for coupling between some of the devices within the system.

While the preferred use of the cable of the present invention is within an aircraft, it should be apparent that the cables according to the present invention can be used in other environments in which the standard IEEE 1394 cable is not appropriate, including other transportation vehicles such as trains, busses, ferries and cruise ships. Specifically, the cable of the present invention is suitable for use in any environment where a thinner diameter IEEE 1394 cable is necessary.

The cable 20 of the preferred embodiment, illustrated in Figure 2, has a length of 4.5 meters. The conductors 22, 24, 26 and 28 are each preferably 24 AWG (American Wire Gauge) silver tinned copper wires. Each conductor 22, 24, 26 and 28 includes its own separate insulation which is preferably expanded PTFE. Each conductor 22, 24, 26 and 28 and its corresponding insulation are encased by a respective jacket 23, 25, 27 and 29. The filler material 30 is preferably expanded PTFE and is used to maintain the relative perpendicular orientation of the differential pairs of the conductors. Alternatively, the filler material 30 can be any other appropriate non-conductive material. The inner shield 32 and the outer shield 36 are preferably braided shields constructed of tin coated copper braid material. Alternatively, any appropriate shield material can be used. The shield separator 34 is preferably constructed of foil-free edge aluminum/polyester tape used for electrical isolation between the inner and outer shields and to provide additional high frequency shielding. Alternatively, any appropriate non-conducting, dielectric insulating tape can be used. The jacket 38 is preferably constructed of extruded FEP. The differential pairs of conductors preferably have a characteristic differential impedance of 110 ohms, per the IEEE 1394 specification.

In order to simulate the other requirements of the IEEE 1394 specification, the longer length cables of the alternate embodiments of the present invention incorporate heavier gauge wire for the conductors 22, 24, 26 and 28 used to carry the differential signals TPA and TPB. Specifically, for lengths of cable up to 15 meters, the conductors 22, 24, 26 and 28 are 20 gauge silver tinned copper wires. For lengths of cable up to 25 meters, the conductors 22, 24, 26 and 28 are 18 gauge silver tinned copper wires. The heavier gauge wire ensures that the strength of these signals is not degraded and that attenuation is limited to meet performance requirements over the entire length of the longer cable. However, the heavier gauge wire also increases the diameter of the cables having longer lengths. The other materials, characteristics and properties of the cable are preferably identical between the cables of different lengths.

A block diagram of the assembly and connection of the quad cable of the present invention is illustrated in Figure 3. The cable 20 is shown connected to a receiving connector 42 which can either be at a port within a device or a repeater. The receiving connector 42 is coupled to appropriate unit electronics at the port within the device or repeater housing the receiving connector. The cable connector at the end of the cable 20 is plugged into the receiving connector 42 in a known manner. The conductors 22, 24, 26 and 28 are coupled to appropriate pins within the cable connector which correspond to pin receivers within the receiving connector 42. The inner shield 32 which encloses all four of the signal conductors 22, 24, 26 and 28 is also coupled to a pin within the cable connector. The outer shield 36 which encloses all four of the signal conductors 22, 24, 26 and 28 and the inner shield 32, is coupled to ground through the connector housing, when the cable 20 is connected to the receiving connector 42. Within the unit electronics at the port housing the receiving connector 42, a capacitor C1 is preferably coupled between the inner shield 32 and the outer shield 36 in order to AC couple the inner shield 32 and the outer shield 36 and properly maintain electrical isolation between the shields 32 and 36.

As discussed above, the IEEE 1394 specification requires that the power signals VP and VG are carried on wires within the cable. However, in the preferred embodiment of the present invention, the cable 20 only includes the conductors 22, 24, 26 and 28 and does not include any DC power conductors. Within the preferred embodiment of the present invention, DC power is provided separately to the devices within the IEEE 1394

network, outside of the cable 20. The DC power is either provided locally by each active device or by a separate power cable 44, as illustrated in Figure 3.

Alternatively, as illustrated in Figure 4, the cable 50 includes a quad cable 20 and a separate power VP wire 48 and ground VG wire 46 enclosed within an overall cable jacket 52. The components within the quad cable 20 are identical to the components of the cable illustrated in Figure 2 and discussed above. The power VP wire 48 and ground VG wire 46 are encased between the quad cable 20 assembly and the overall cable jacket 52. Because of the addition of the separate power VP wire 48 and ground VG wire 46, the diameter of the cable 50 is greater than the diameter of the cable 20.

In Table 1, below, the diameter and weight of a 20 meter shielded twisted pair cable, as taught in U.S. Patent Application Serial Number 08/714,659, referred to above, is compared to a 20 meter quad cable constructed according to the preferred embodiment of the present invention. Each of the cables use 20 gauge wire. For this comparison, the weight of the DC conductors within the shielded twisted pair cable was subtracted from the total weight of the cable since the quad cable of the preferred embodiment does not include the DC power conductors.

IEEE 1394 CABLE TYPE	OUTER DIAMETER	WEIGHT per 1000 feet
STP (18 AWG)	0.75 inches	184.9 pounds
Quad (18 AWG)	0.285 inches	66.5 pounds

Table 1: Comparison of Cable Diameter and Weight

As illustrated by Table 1, a 20 meter quad cable constructed according to the preferred embodiment of the present invention is much smaller and lighter than the shielded twisted pair cable.

Within the quad cable of the preferred embodiment of the present invention, the conductors 22, 24, 26 and 28 have a characteristic impedance of 110 ohms \pm 6 ohms, per the IEEE 1394 specification. However, within an alternate embodiment of the present invention, the conductors 22, 24, 26 and 28 have a characteristic impedance of 105 ohms \pm 5 ohms. This lower characteristic impedance allows the quad cable of the present

invention to be used within an IEEE 1394 serial bus network or to provide data transmission for serial busses other than the IEEE 1394 serial bus, if the network is not an IEEE 1394 network. Other serial busses typically have a characteristic impedance of 100 ohms \pm 10 ohms. When wiring an aircraft or other vehicle or building, it is desirable to include a single set of cables which can be used for data transmission between devices no matter what type of serial bus is implemented. Otherwise, multiple cables would have to be run for different networks of devices. Accordingly, the quad cable of this alternate embodiment includes a characteristic impedance of 105 ohms \pm 5 ohms. Therefore, the quad cable of the present invention, while intended for use within IEEE 1394 serial bus networks, can also be used between devices within other types of serial bus networks.

The present invention has been described in terms of specific embodiments incorporating details to facilitate the understanding of principles of construction and operation of the invention. Such reference herein to specific embodiments and details thereof is not intended to limit the scope of the claims appended hereto. It will be apparent to those skilled in the art that modifications may be made in the embodiment chosen for illustration without departing from the spirit and scope of the invention.

C L A I M S

We Claim:

- 1 1. A quad cable for use within an IEEE 1394 serial bus network comprising:
 - 2 a. a first pair of differential conductors arranged parallel to each other over a
3 length of the quad cable for carrying differential signals between IEEE 1394
4 devices; and
 - 5 b. a second pair of differential conductors arranged parallel to each other over
6 the length of the quad cable for carrying differential signals between IEEE
7 1394 devices.

- 1 2. The quad cable as claimed in claim 1 further comprising a first connector at
2 a first end of the cable and a second connector at a second end of the cable, the first and
3 second connectors each including a first and second pin coupled to the first pair of
4 differential conductors and a third and fourth pin coupled to the second pair of differential
5 conductors.

- 1 3. The quad cable as claimed in claim 2 further comprising an inner shield
2 formed around the first and second pair of differential conductors.

- 1 4. The quad cable as claimed in claim 3 further comprising an outer shield
2 formed around the first and second pair of differential conductors and the inner shield.

- 1 5. The quad cable as claimed in claim 4 further comprising a shield separator
2 positioned between the inner shield and the outer shield for maintaining electrical isolation
3 between the inner and outer shields.

- 1 6. The quad cable as claimed in claim 5 further comprising a jacket formed
2 around the outer shield.

- 1 7. The quad cable as claimed in claim 6 wherein the inner and outer shields
2 are both braided shields.
- 1 8. The quad cable as claimed in claim 7 wherein the jacket is flame retardant.
- 1 9. A quad cable for use within an IEEE 1394 serial bus network comprising:
2 a. a first pair of differential conductors arranged parallel to each other over a
3 length of the quad cable;
4 b. a second pair of differential conductors arranged parallel to each other over
5 the length of the quad cable;
6 c. an inner braided shield formed around the first and second pair of
7 differential conductors;
8 d. an outer braided shield formed around the first and second pair of
9 differential conductors and the inner braided shield; and
10 e. a jacket formed around the outer braided shield.
- 1 10. The quad cable as claimed in claim 9 further comprising a first cable
2 connector at a first end of the cable and a second cable connector at a second end of the
3 cable, the first and second cable connectors each including a first and second pin coupled
4 to the first pair of differential conductors and a third and fourth pin coupled to the second
5 pair of differential conductors.
- 1 11. The quad cable as claimed in claim 10 wherein the first and second cable
2 connectors are for coupling to a receiving connector including a plurality of pin receivers
3 and a housing, wherein the receiving connector includes a first, second, third and fourth
4 pin receiver for receiving and electrically coupling to the first, second, third and fourth
5 pins.
- 1 12. The quad cable as claimed in claim 11 wherein the first and second cable
2 connectors further include a fifth pin coupled to the inner shield and the receiving
3 connector includes a corresponding fifth pin receiver for receiving and electrically
4 coupling to the fifth pin.

- 1 13. The quad cable as claimed in claim 12 wherein the outer shield is coupled
2 to the connector housing.
- 1 14. The quad cable as claimed in claim 13 wherein a capacitor is coupled
2 between the outer shield and the inner shield.
- 1 15. The quad cable as claimed in claim 14 wherein the first and second
2 differential pair of conductors have a characteristic impedance of 110 ohms.
- 1 16. The quad cable as claimed in claim 14 wherein the first and second
2 differential pair of conductors have a characteristic impedance less than 110 ohms for also
3 transmitting data between non IEEE 1394 devices.
- 1 17. A quad cable for use within an IEEE 1394 serial bus network comprising:
2 a. a first pair of differential conductors arranged parallel to each other over a
3 length of the quad cable;
4 b. a second pair of differential conductors arranged parallel to each other over
5 the length of the quad cable;
6 c. an inner braided shield formed around the first and second pair of
7 differential conductors;
8 d. an outer braided shield formed around the first and second pair of
9 differential conductors and the inner braided shield;
10 e. a shield separator positioned between the inner braided shield and the outer
11 braided shield for maintaining electrical isolation between the inner braided
12 shield and the outer braided shield; and
13 f. a flame retardant jacket formed around the outer braided shield.
- 1 18. The quad cable as claimed in claim 17 further comprising a first cable
2 connector at a first end of the cable and a second cable connector at a second end of the
3 cable, the first and second cable connectors each including a first and second pin coupled
4 to the first pair of differential conductors and a third and fourth pin coupled to the second
5 pair of differential conductors.

1 19. The quad cable as claimed in claim 18 wherein the first and second cable
2 connectors are for coupling to a receiving connector including a plurality of pin receivers
3 and a housing, wherein the receiving connector includes first, second, third and fourth pin
4 receivers for receiving and electrically coupling to the first, second, third and fourth pins.

1 20. The quad cable as claimed in claim 19 wherein the first and second cable
2 connectors further include a fifth pin coupled to the inner shield and the receiving
3 connector includes a corresponding fifth pin receiver for receiving and electrically
4 coupling to the fifth pin.

1 21. The quad cable as claimed in claim 20 wherein the outer shield is coupled
2 to the connector housing.

1 22. The quad cable as claimed in claim 21 wherein the receiving connector
2 further includes a capacitor coupled between the connector housing and the fifth pin
3 receiver.

1 23. The quad cable as claimed in claim 22 wherein the first and second
2 differential pair of conductors have a characteristic impedance less than 110 ohms for also
3 transmitting data between non IEEE 1394 devices.

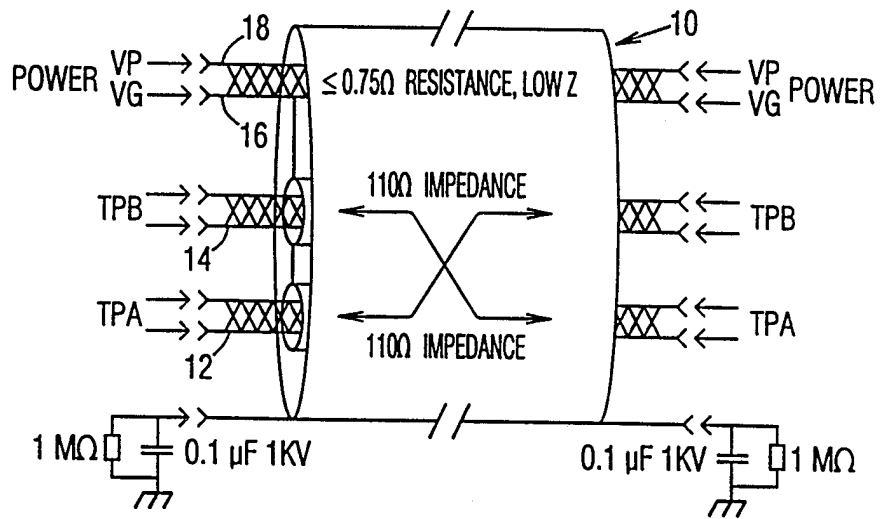

Fig. 1
(Prior Art)

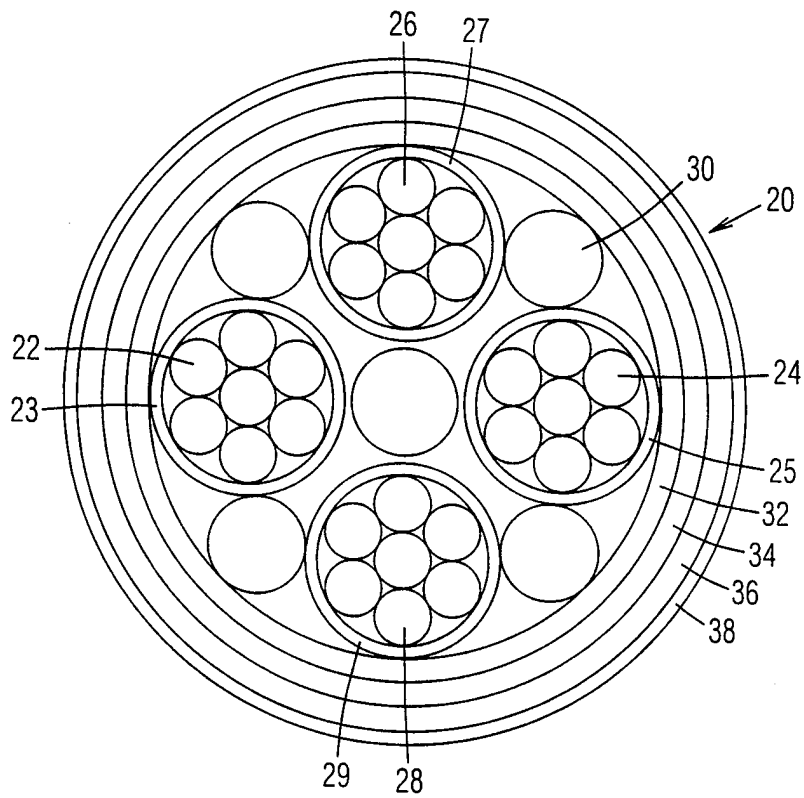

Fig. 2

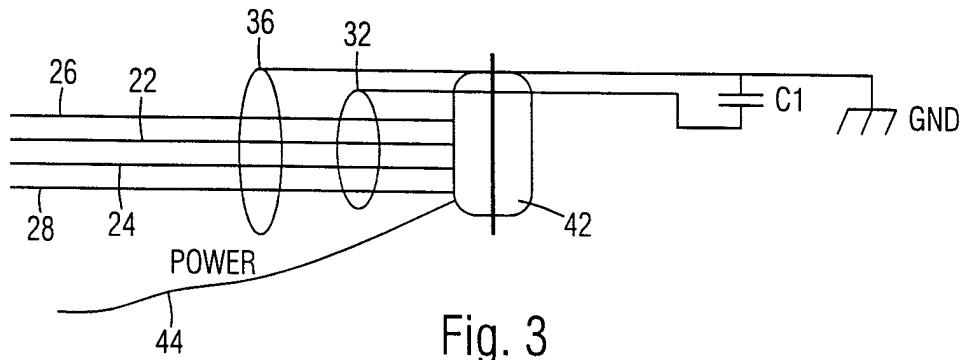

Fig. 3

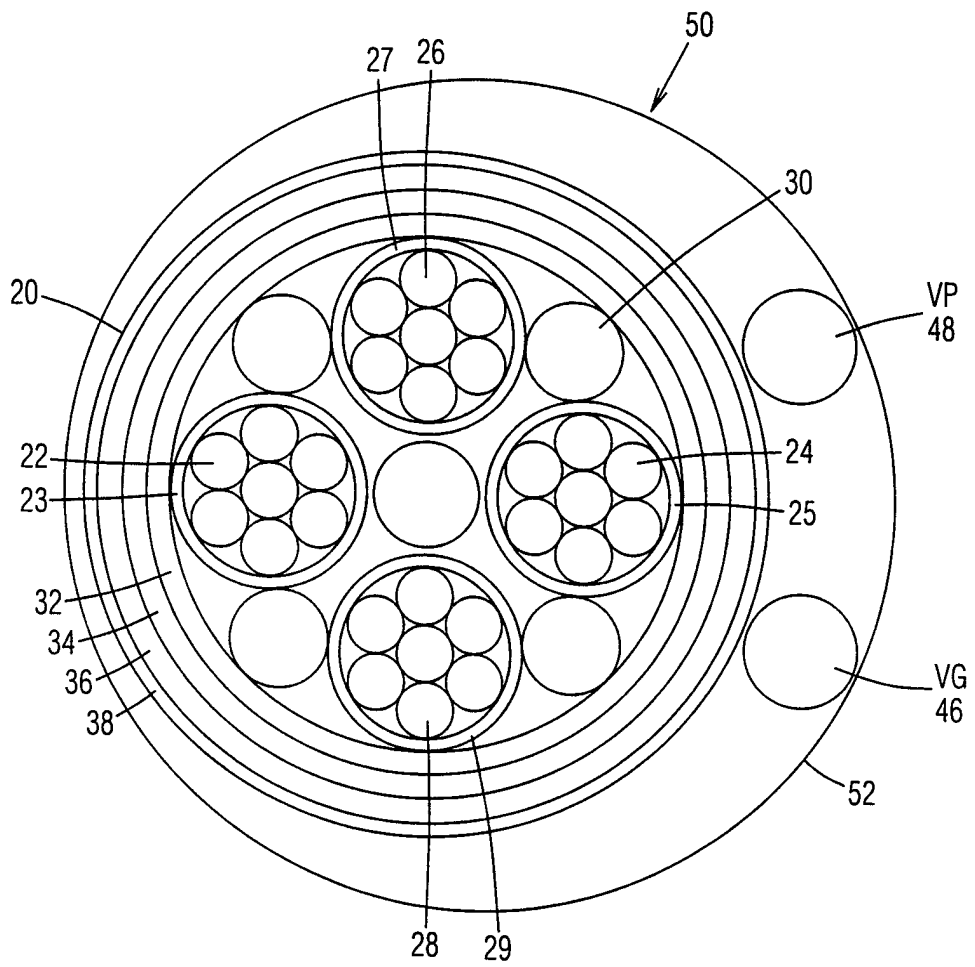

Fig. 4