

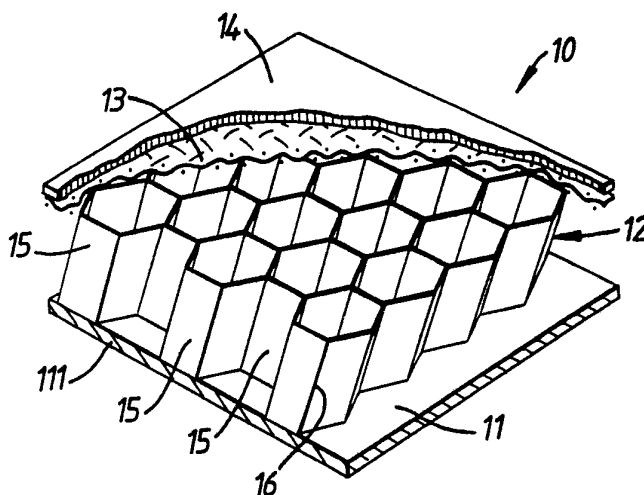

INTERNATIONAL APPLICATION PUBLISHED UNDER THE PATENT COOPERATION TREATY (PCT)

<p>(51) International Patent Classification ⁵ : B32B 3/12, 3/10, G10K 11/16</p>	<p>A1</p>	<p>(11) International Publication Number: WO 92/12854 (43) International Publication Date: 6 August 1992 (06.08.92)</p>
<p>(21) International Application Number: PCT/GB92/00118 (22) International Filing Date: 21 January 1992 (21.01.92) (30) Priority data: 9101395.3 22 January 1991 (22.01.91) GB (71) Applicant (for all designated States except US): SHORT BROTHERS PLC [GB/GB]; P.O. Box 241, Airport Road, Belfast BT3 9DZ (GB). (72) Inventor; and (75) Inventor/Applicant (for US only): WILSON, Robert, Samuel [GB/GB]; 38 Earlswood Road, Belfast BT4 3DY (GB). (74) Agents: MOON, Donald, Keith et al.; Brewer & Son, Quality House, Quality Court, Chancery Lane, London WC2A 1HT (GB).</p>		<p>(81) Designated States: AT (European patent), AU, BE (European patent), BR, CA, CH (European patent), DE (European patent), DK (European patent), ES (European patent), FR (European patent), GB (European patent), GR (European patent), IT (European patent), JP, LU (European patent), MC (European patent), NL (European patent), SE (European patent), US.</p> <p>Published <i>With international search report.</i></p>

(54) Title: STRUCTURAL CELLULAR COMPONENT



(57) Abstract

A structural cellular component (12) for a noise attenuation panel (10) comprises walls which provide bounding surfaces for an array of cells (15) and which terminate at opposite faces of the component. The walls forming the cells (15) extend to at least one of the faces of the component at an angle or angles inclined to the normal to that face. The noise attenuation panel (10) is formed from the cellular component (12), a backing component part (11) which extends across the rear face of the cellular component (12) and a facing component (13, 14) which extends across the front face of the cellular component (12). The facing component part (13, 14) comprises or includes an outer facing sheet (14) which is made of a porous permeable thermoplastics material. The panel is intended for use in an aero engine at a surface subjected to the passage across it of gaseous flow and is so positioned that its front face forms the surface subjected to passage of gaseous flow across it.

FOR THE PURPOSES OF INFORMATION ONLY

Codes used to identify States party to the PCT on the front pages of pamphlets publishing international applications under the PCT.

AT	Austria	FI	Finland	MI	Mali
AU	Australia	FR	France	MN	Mongolia
BB	Barbados	GA	Gabon	MR	Mauritania
BE	Belgium	GB	United Kingdom	MW	Malawi
BF	Burkina Faso	GN	Guinea	NL	Netherlands
BG	Bulgaria	GR	Greece	NO	Norway
BJ	Benin	HU	Hungary	PL	Poland
BR	Brazil	IE	Ireland	RO	Romania
CA	Canada	IT	Italy	RU	Russian Federation
CF	Central African Republic	JP	Japan	SD	Sudan
CG	Congo	KP	Democratic People's Republic of Korea	SE	Sweden
CH	Switzerland	KR	Republic of Korea	SN	Senegal
CI	Côte d'Ivoire	LI	Liechtenstein	SU	Soviet Union
CM	Cameroon	LK	Sri Lanka	TD	Chad
CS	Czechoslovakia	LU	Luxembourg	TG	Togo
DE	Germany	MC	Monaco	US	United States of America
DK	Denmark	MG	Madagascar		
ES	Spain				

Structural Cellular Component

The present invention relates to structural cellular components and is particularly although not exclusively concerned with a structural cellular component for a noise attenuation panel for use in the attenuation of noise in aero engines.

In patent application publication No. GB-A-2223448 a noise attenuation panel is disclosed having a backing sheet, a facing sheet and a cellular core having a multiplicity of opened ended juxtaposed cells. The backing sheet extends across the open ends of the cells at the rear of the core and the facing sheet extends across the open ends of the cells at the front of the core. In the panel disclosed, the facing sheet is made of a porous permeable thermoplastics material preferably produced by a powder sintering process and the backing sheet is imperforate and impermeable.

The noise attenuation panel disclosed in GB-A-2223448 is proposed for use in reducing turbine engine noise and is formed as an integral part of an aero engine structure. For example, it is proposed that the panels form part of a cowling surrounding a turbine engine inlet duct or be placed adjacent a high turbulence region of the fan of a turbofan engine.

The cellular core in the panel specifically disclosed in GB2223448A is furthermore formed by cells having wall portions which extend parallel to each other and perpendicular to the backing and facing sheets.

While the panel specifically disclosed in GB-A-2223448

has been found to be successful for use in aero engine environments, drawbacks may be found in the use of a cellular core in which the cells are formed as described, that is to say, with the wall portions extending parallel to each other and perpendicular to the backing and facing sheets.

According to a first aspect of the present invention there is provided a structural cellular component for a noise attenuation panel, the component comprising wall portions which provide bounding surfaces for an array of cells and which terminate at opposite faces of the component, characterised in that the wall portions or predetermined ones of the wall portions forming the cells extend to at least one of the faces of the component at an angle or angles inclined to the normal to that face.

There is currently a trend towards the development of ultra high bypass (UHB) ratio turbofan engines giving rise to associated low blade passage frequencies of the fan. In order to provide for noise attenuation at these low frequencies the depth of the cells of the cellular core of the previously proposed panel of GB 2223448A needs to be increased, giving rise an increase in the depth of the panel. This increase in panel depth is however found to be undesirable for the environments in which the panel is used.

Accordingly there is a need to provide a structural cellular component for a noise attenuation panel which is effective to attenuate noise at the lower frequencies generated in the large diameter UHB ratio turbofan engines without requiring an undesirable increase in panel depth.

A first embodiment of the first aspect of the present invention is characterised in that the wall portions of the cellular component provide bounding surfaces for an array of juxtaposed cells which terminate in open ends at one of the faces of the component with the wall portions extending to that face at angles inclined to the normal to that face.

In the first embodiment of the invention hereinafter to be described, the cells also terminate in open ends at the opposite face of the component with the wall portions extending to the opposite face at angles inclined to the normal to that face.

Preferably, the wall portions extend to the face or faces of the component along lines which are parallel to each other.

In preferred embodiments of the invention hereinafter to be described the angle at which the wall portions are inclined to the normal to the or each face of the component is in excess of 20° .

In the embodiments of the invention hereinafter to be described, the cells are of constant cross-section with the lateral edges of each cell lying along lines parallel to each other. In the embodiments described the cells are of hexagonal cross-section but in alternative embodiments of the invention the cells may conform to an isogrid or orthogrid pattern.

In alternative embodiments of the invention not illustrated by the drawings the wall portions or predetermined ones of the wall portions extend to the face or each face of the component along lines which are

not parallel to each other. In these embodiments, the cells may be of pyramidal form or in the form of truncated pyramids.

According to a second aspect of the present invention there is provided a noise attenuation panel comprising a cellular component part in the form of a component according to the first aspect of the invention, a backing component part extending across one face of the cellular component part at the rear thereof and a facing component part extending across the other face of the cellular component part at the front thereof.

In a preferred embodiment of the invention according to its second aspect, the facing component part comprises or includes an outer facing sheet which is made of a porous permeable thermoplastics material. Preferably, the porous permeable thermoplastics material for the outer facing sheet is produced by powder sintering a thermoplastics material.

In an embodiment of the invention hereinafter to be described the facing component part further includes an inner facing sheet made from an open square weave fabric having apertures constituted by the openings between adjacent warp and weft threads of the fabric.

In yet another embodiment of the invention hereinafter to be described the cellular component part comprises an upper cellular element in the form of a component according to the first aspect of the invention, a lower cellular element in the form of a component according to the first aspect of the invention and positioned beneath the upper cellular element and a septum sheet which extends across the lower cellular element at an upper

face thereof and across the upper cellular element at the lower face thereof.

In an embodiment of the invention hereinafter to be described the upper and lower cellular elements comprise identical arrays of cells inclined to the normal to the panel. In one such embodiment the upper and lower cellular elements are arranged one above the other and the cells of the one are inclined to the normal to the panel in the same direction as the cells of the other.

In an embodiment of the invention hereinafter to be described the two cellular elements are so positioned and arranged that the upper open ends of the cells of the upper cellular element are in registration with the open upper ends of the cells of the lower cellular element, whereby the lower open ends of the cells of the upper element are out of registration with the upper open ends of the cells of the lower element.

In an alternative embodiment of the invention not illustrated the two cellular elements are so arranged that the lower open ends of the cells of the upper cellular element are in registration with the upper open ends of the cells of the lower cellular element, whereby the cells of the lower cellular element form a continuation of the cells of the upper cellular element.

In yet another embodiment of the invention hereinafter to be described, the upper and lower cellular elements are so positioned and arranged one above the other that the cells of the one element are inclined to the normal to the panel in a direction opposite to that of the cells of the other element.

The septum sheet may be constructed from a porous permeable thermoplastics material or alternatively made of a stainless steel fabric. The upper cellular element or the lower cellular element or both may be made from an impermeable material or from a porous permeable thermoplastics material.

According to a third aspect of the present invention, there is provided an aero engine having a surface subjected to the passage across it of gaseous flow and a noise attenuation panel according to the second aspect of the invention so positioned that its front face forms the surface or part of the surface subjected to passage of the gaseous flow across it.

Embodiments of the invention will now be described by way of example with reference to the accompanying drawings in which:-

Fig. 1 is a schematic isometric view from above of a noise attenuation panel embodying a structural cellular component according to a first embodiment of the invention;

Fig. 2 is a schematic cross section of an end region of the panel shown in Fig. 1, secured to a supporting channel member;

Figs. 3, 4 and 5 are schematic cross sectional scrap-views of noise attenuation panels according to three further embodiments of the invention; and

Fig 6 is a schematic cross-section of an aero engine embodying noise attenuation panels according to the invention.

Referring first to Figs. 1 and 2, the noise attenuation panel 10 comprises a backing sheet 11, a cellular core 12 and inner and outer facing sheets 13 and 14.

The cellular core 12 comprises a multiplicity of open-ended juxtaposed cells 15 of hexagonal cross section to provide a honeycomb configuration in which the lateral edges 16 are (i) parallel to each other, (ii) lie in planes which are perpendicular to the backing sheet 11 and parallel to the edge 111 of the sheet 11 and (iii) lie on lines which are inclined to the normal to the backing sheet, whereby the length of the cells 15 between the backing sheet 11 and the inner facing sheet 13 is greater than the distance of separation of the two sheets 11 and 13.

The backing sheet 11 is unperforated and made from an impermeable sheet material, as shown in Fig. 2, and is secured by an epoxy resin adhesive E1 to the lower face of the cellular core 12.

The inner facing sheet 13 is made from an open square weave fabric formed from a carbon fibre/resin matrix composite material and the weave is such as to provide apertures constituted by the openings between adjacent warp and weft threads of the fabric. The fabric is preferably so woven as to produce a proportion of open aperture area relative to the total surface area of the sheet of around 30%. At the same time, the fabric is so woven that a relatively large number of its apertures are contained within the bounds of each cell 15 of the cellular core 12.

The outer facing sheet 14 comprises a sheet of a porous permeable thermoplastics material produced by powder sintering the thermoplastic. Examples of suitable

thermoplastics materials include polyether ketone, polyether ether ketone, polyaromatic ketone, polyphenylene sulphide, polyamide-imide, thermoplastic polyimide, polyether-imide, polyurethane and polyethylene.

The outer facing sheet 14 is bonded to the inner facing sheet 13 and the inner facing sheet 13 is, as shown in Fig.2, secured to the upper face of the cellular core 12 by means of an epoxy resin adhesive E2.

During manufacture of the panel 10, it may be found advantageous to form the inner woven facing sheet 13 in a part cured condition and to bring the outer facing sheet 14 into contact with it during a final curing step so that the resin serves to bond the two sheets together. The combined sheets 13 and 14 may then be secured to the upper face of the cellular core 12 using the epoxy resin adhesive E2.

The epoxy adhesives E1 and E2 may for example be obtained from Ciba-Geigy Plastics & Additives Company Limited of Cambridge, England. Adhesives and resins need not however be epoxy resin adhesives, but could for example be a phenolic, polyimide or thermoplastics resin.

The backing sheet 11 is imperforate and made of a non-porous impermeable material and may be made of any of the following materials:-

- (i) A carbon/thermoplastic composite where for example the thermoplastic is polyether ether ketone, the material being automatically tape wound or hand laid.

- (ii) A carbon/epoxy resin.
- (iii) An aluminium alloy.

The cellular core 12 in the embodiment of the invention illustrated is made from a non-porous impermeable sheet of any of the following materials:-

- (i) A thermoplastic such as polyether ether ketone.
- (ii) A polyester fabric/phenolic resin.
- (iii) A fibreglass/phenolic resin.
- (iv) A NOMEX/phenolic resin (NOMEX being a registered trade mark for an aramid fibre paper impregnated with various resins to produce a structural material. By "aramid is meant an aromatic polyamide polymer.
- (v) An aluminium alloy.

The cellular core 12 may however if desired be made of a porous permeable thermoplastics material and may be in the same form as the outer facing sheet 14.

The panel 10 is of arcuate form, possibly of double curvature, and is embodied as a structural part of a duct of a nose cowl of a turbofan aero engine, the panel 10 being one of several arcuate panels disposed just upstream of the fan of the engine. It is, of course, of vital importance that the panel does not deteriorate in

use and, in particular, that no part of it becomes detached from its supporting structure. The structure will usually include supporting channel members of which only one member 17 is shown in Fig. 2. The panel 10 is secured to the member 17 by bonding the inner facing sheet 13 to an outer face of a flange 18 of the channel member 17 using a carbon bond 19 and by bonding the backing sheet 11 to the outer face of a flange 20 of the channel member 17 using a carbon to carbon bond 21. The gap between the panel 10 and the base 22 of the channel member 17 may be sealed or closed by use of a mastic 23.

A panel having an outer facing sheet 14 made of a porous thermoplastics material as described with reference to Figs. 1 and 2 has been found to give rise to several advantages over the panels of the prior proposals, including the following:-

(1) The cellular structure of the facing sheet when produced by the powder sintering technique can be made to meet permeability requirements over a wide range. The cellular structure may be made permeable to gaseous flow over a wide range of tightly controlled flow and resistance requirements which will be engine dependent and non permeable to a wide range of liquids and solid contaminants.

(2) The cellular structure of the facing sheet when produced by the powder sintering technique provides a highly complex interference flow path as a result of which the noise attenuation properties are greatly enhanced over other forms of perforate and porous material.

(3) The very smooth surface of the facing sheet when

produced by the powder sintering technique has substantial acoustic/air flow advantages over other perforate and porous forms. There is a lower flow resistance to high speed air flow, and therefore the overall aero engine power plant efficiency is improved over that obtained using the previously proposed panels;

(4) the sound attenuation is greater and covers a wider frequency range than that of the previously proposed panels;

(5) the thermoplastic component parts do not have the problem of metal corrosion;

(6) the panel is lighter than the previously proposed panels;

(7) there is an improved "blade-off" energy absorption compared with the previously proposed structures; and

(8) there is an improved appearance.

In addition to the above-mentioned advantages, the acoustic absorbing properties of the panel are improved by an appropriate inclining of the cells of the core to the backing and facing sheets, thereby extending the length of the cells without increasing the panel thickness and thereby extending the sound attenuation of the panel to the lower frequencies generated in the large diameter UHB ratio turbofan engines.

Referring now to Fig. 3, a panel according to a second embodiment of the invention is illustrated, in which the cellular core 12 of the embodiment of the invention described with reference to Figs. 1 and 2 is replaced by

a split cellular core comprising an upper cellular element 121 having a multiplicity of open-ended juxtaposed inclined cells 151, a lower cellular element 122 having a further multiplicity of open-ended juxtaposed inclined cells 152 and a septum sheet 24 which extends across the ends of the cells 152 of the lower cellular element 122 at the upper face thereof and the ends of the cells 151 of the upper cellular element 121 at the lower face thereof. The cells of the two cellular elements 121 and 122 form identical arrays of the inclined cells as described with reference to Fig 1 and are arranged one above the other. In Fig 3, the upper open ends of the cells 151 and 152 are arranged one above the other, as a consequence of which the lower open ends of the cells 151 of the upper element 121 are not in alignment with the upper open ends of the cells 152 of the lower element 122. For some purposes, however, it may be found advantageous so to mount the elements 121 and 122 that the cells 152 form a continuation of the cells 151.

The backing sheet 11, the inner and outer facing sheets 13 and 14 and the upper and lower cellular elements 121 and 122 of the panel shown in Fig. 3 are constructed and bonded together in the same manner as the sheet 11, core 12 and facing sheets 13 and 14 of the embodiment described with reference to Figs. 1 and 2, with the backing sheet 11 being secured to the lower face of the lower cellular element 122 and the inner and outer facing sheets 13 and 14 being secured to the upper face of the upper element 121.

The septum sheet 24 is likewise bonded to adjacent faces of the cellular elements 121 and 122. It is constructed from a porous permeable thermoplastics material and may

take the same form as that of the outer facing sheet 14 of the panel described with reference to Figs. 1 and 2.

In a third embodiment of the invention illustrated in Fig. 4, the inner facing sheet 13 of the panel described with reference to Figs. 1 and 2 is omitted and the outer facing sheet 14, which is made of the porous thermoplastics material, is adhered direct to the upper face of the cellular core 12 using adhesive E2.

In Fig. 5, a fourth embodiment of the invention is illustrated which corresponds to the embodiment of the invention described with reference to Fig. 3, except that the cells 151 of the upper cellular element 121 are inclined in one direction and the cells 152 of the lower element 122 are inclined in the opposite direction and except insofar as the inner facing sheet 13 is omitted and the outer facing sheet 14 is adhered direct to the face of the upper cellular element 121 in the manner described for the panel illustrated in Fig. 4.

In yet another embodiment of the invention (not illustrated) the panel described with reference to Fig. 3 may be modified by making the upper cellular element 121 or the lower cellular element 132 or both of a porous thermoplastics material and may be made from any of the materials proposed for the outer facing sheet 14 of the panel described with reference to Figs. 1 and 2.

The septum sheet 24 in the panels illustrated in Figs. 3 and 5 is described as being made of a porous thermoplastics material. It may however if desired be made of a stainless steel fabric or any of the above-mentioned materials which are suitable for the inner facing sheet 13, the requirement of course being that the

sheet is either porous and permeable, perforated or apertured.

In the embodiments of the invention hereinbefore described with reference to the drawings, cells 15 of hexagonal cross section have been provided. It will however be appreciated that cells of other cross sections, for example conforming to an isogrid or orthogrid pattern, can alternatively be used.

In the embodiments of the invention hereinbefore described with reference to the drawings, the cells 15 are prismatic in form, that is to say, are of constant cross section with the lateral edges 16 of each cell 15 lying along lines parallel to each other. It will however be appreciated that cells of non-constant cross section may be provided in which the lateral edges or some of the lateral edges of each cell 15 are not equally inclined, as for example where the cells are of pyramidal form or in the form of truncated pyramids, so as to provide cells in which the effective length varies within the cell.

Referring now to Fig 6, an aero engine 25 is schematically illustrated and includes a turbofan power unit 26 mounted within a nacelle 27 suspended from a pylon 32. The nacelle 27 includes a nose cowl 28 having an outer wall 29 and an inner wall 30. The inner wall 30 is in part formed by noise attenuation panels P which may take the form of panels as described and illustrated with reference to Figs. 1 to 5. The panels P are arranged to form part of the inner wall of the nose cowl 28 and serve to reduce noise created by the high speed flow of air passing through the duct 31 into the power unit 26, as well as to reduce noise generated by the fan blades of

the unit 26.

It is to be emphasised that the panels in Fig. 6 are not employed to reduce air noise by a reduction of the air speed by passage of the air through the panels, but by contrast acoustic attenuation is achieved without affecting the speed of the air which generates the noise, that is to say, the air does not pass through the noise attenuation panels P.

In the aero engine mounting arrangement illustrated in Fig. 6, the power unit is carried by the wing mounted pylon 32. It will however be appreciated that the noise attenuation panels according to the present invention may be equally well be employed for reducing noise in other aero engine installations.

CLAIMS

1. A structural cellular component for a noise attenuation panel, the component comprising wall portions which provide bounding surfaces for an array of cells and which terminate at opposite faces of the component, characterised in that the wall portions or predetermined ones of the wall portions forming the cells extend to at least one of the faces of the component at an angle or angles inclined to the normal to that face.
2. A component according to claim 1 characterised in that the wall portions of the cellular component provide bounding surfaces for an array of juxtaposed cells which terminate in open ends at one of the faces of the component with the wall portions extending to that face at angles inclined to the normal to that face.
3. A component according to claim 2 characterised in that the cells also terminate in open ends at the opposite face of the component with the wall portions extending to the opposite face at angles inclined to the normal to that face.
4. A component according to claim 3 characterised in that the wall portions extend to the face or faces of the component along lines which are parallel to each other.
5. A component according to claim 4 characterised in that the angle at which the wall portions are inclined to the or each face of the component is in excess of 20°.
6. A component according to claim 4 or 5 characterised in that the cells are of constant cross

section with the lateral edges of each cell lying along lines parallel to each other.

7. A component according to claim 6 characterised in that the cells are of hexagonal cross section.

8. A component according to claim 6 characterised in that the cells conform to an isogrid or orthogrid pattern.

9. A component according to claim 1,2 or 3 characterised in that the wall portions or predetermined ones of the wall portions extend to the face or each face of the component along lines which are not parallel to each other.

10. A component according to claim 9 characterised in that the cells are of pyramidal form or in the form of truncated pyramids.

11. A noise attenuation panel comprising a cellular component part in the form of a component according to any of claims 1 to 8, a backing component part extending across one face of the cellular component part at the rear thereof and a facing component part extending across the other face of the cellular component part at the front thereof.

12. A panel according to claim 11 characterised in that the facing component part comprises or includes an outer facing sheet which is made of a porous permeable thermoplastics material.

13. A panel according to claim 12 characterised in that the porous permeable thermoplastics material for the

outer facing sheet is produced by powder sintering a thermoplastics material.

14. A panel according to claim 12 or 13 characterised in that the facing component part further includes an inner facing sheet made from an open square weave fabric having apertures constituted by the openings between adjacent warp and weft threads of the fabric.

15. A panel according to any of claims 11 to 14 characterised in that the cellular component part comprises an upper cellular element in the form of a component according to any of claims 1 to 8, a lower cellular element in the form of a component according to any of claims 1 to 8 and positioned beneath the upper cellular element and a septum sheet which extends across the lower cellular element at an upper face thereof and across the upper cellular element at the lower face thereof.

16. A panel according to claim 15 characterised in that the upper and lower cellular elements comprise identical arrays of cells inclined to the normal to the panel.

17. A panel according to claim 15 or 16 characterised in that the upper and lower cellular elements are arranged one above the other and that the cells of the one are inclined to the normal to the panel in the same direction as the cells of the other.

18. A panel according to claim 17 characterised in that the two cellular elements are so positioned and arranged that the upper open ends of the cells of the upper cellular element are in registration with the open

upper ends of the cells of the lower cellular element, whereby the lower open ends of the cells of the upper element are out of registration with the upper open ends of the cells of the lower element.

19. A panel according to claim 17 characterised in that the two cellular elements are so arranged that the lower open ends of the cells of the upper cellular element are in registration with the upper open ends of the cells of the lower cellular element, whereby the cells of the lower cellular element form a continuation of the cells of the upper cellular element.

20. A panel according to claim 15 or 16, characterised in that the upper and lower cellular elements are so positioned and arranged one above the other that the cells of the one element are inclined to the normal to the panel in a direction opposite to that of the cells of the other element.

21. A panel according to any of claims 15 to 20 characterised in that the septum sheet is constructed from a porous permeable thermoplastics material.

22. A panel according to any of claims 15 to 21 characterised in that the septum sheet is made of a stainless steel fabric.

23. A panel according to any of claims 15 to 22 characterised in that the upper cellular element or the lower cellular element or both are made of a porous permeable thermoplastics material.

24. An aero engine having a surface subjected to the passage across it of gaseous flow and a noise

attenuation panel according to any of claims 11 to 23 so positioned that its front face forms the surface or part of the surface subjected to passage of the gaseous flow across it.

25. A structural cellular component for a noise attenuation panel, substantially as hereinbefore described with reference to Figs 1 and 2 or Fig 3, 4 or 5 of the accompanying drawings.

26. A noise attenuation panel substantially as hereinbefore described with reference to Figs 1 and 2 or Fig 3, 4 or 5 of the accompanying drawings.

27. An aero engine having a noise attenuation panel according to claim 26 mounted as hereinbefore described with reference to Fig 6.

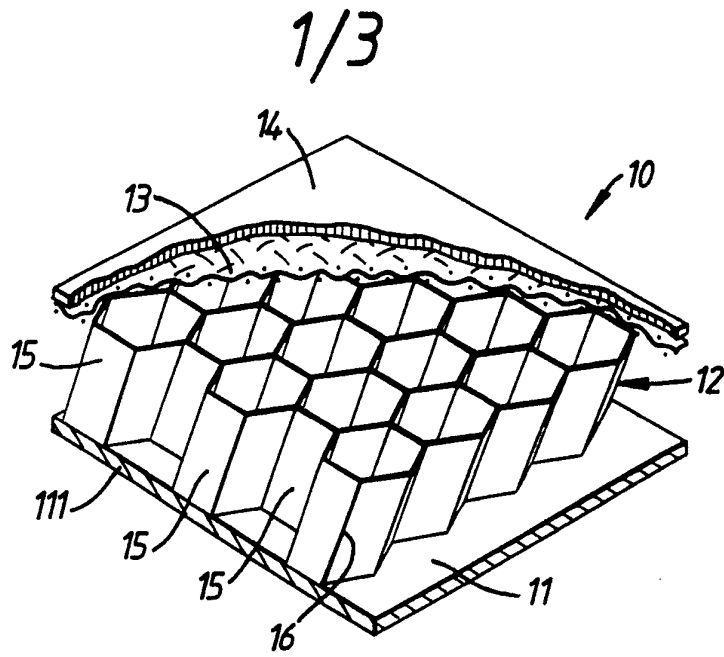

Fig. 1.

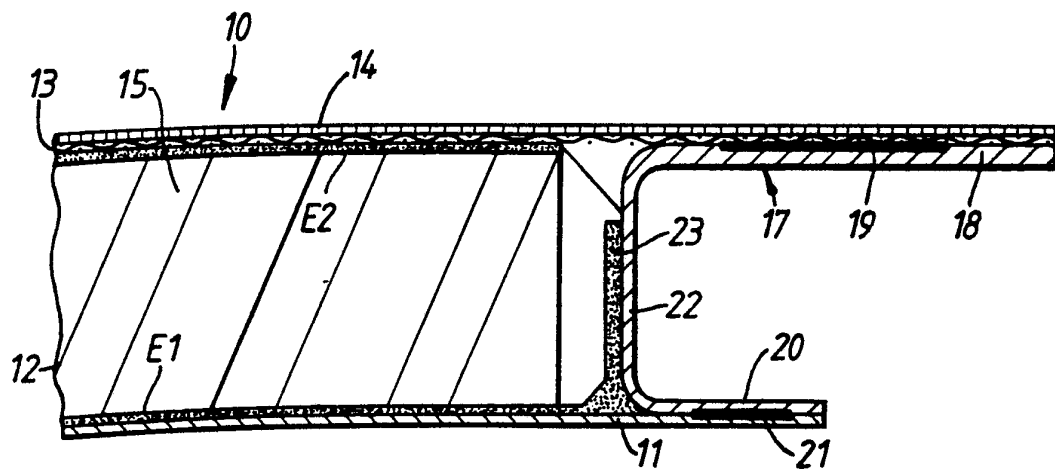

Fig. 2.

2/3

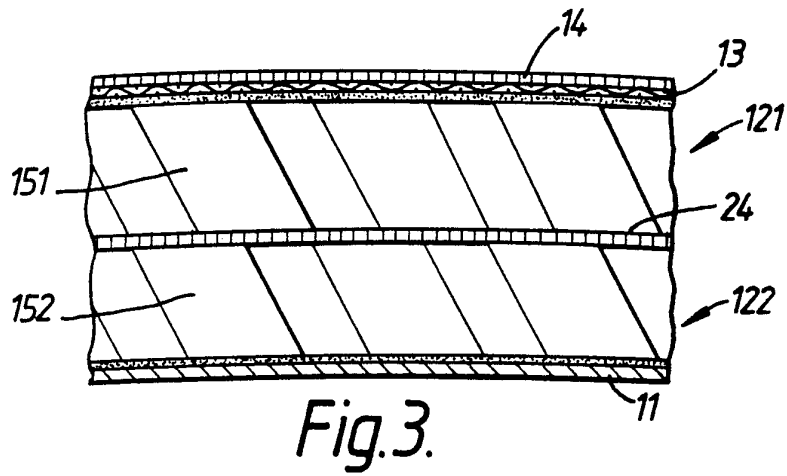

Fig. 3.

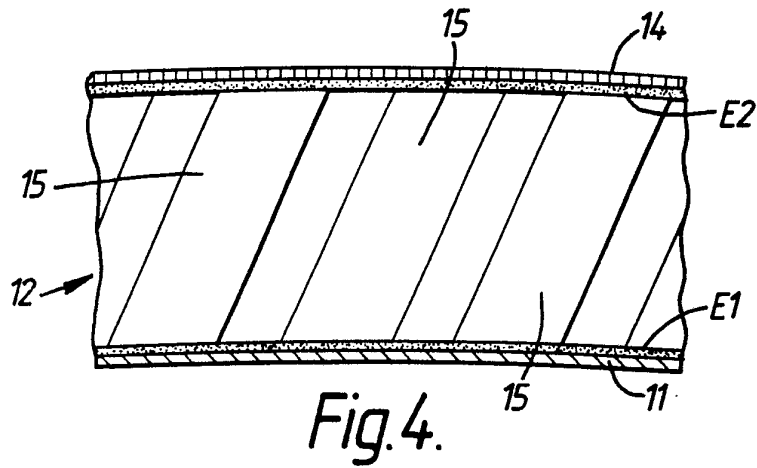

Fig. 4.

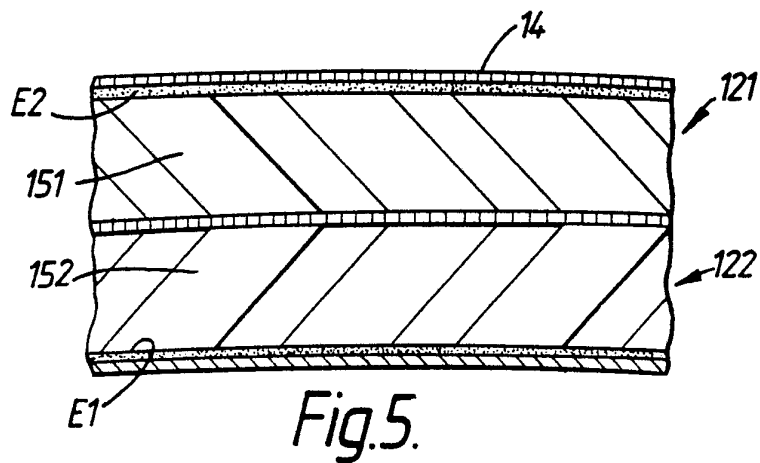

Fig. 5.

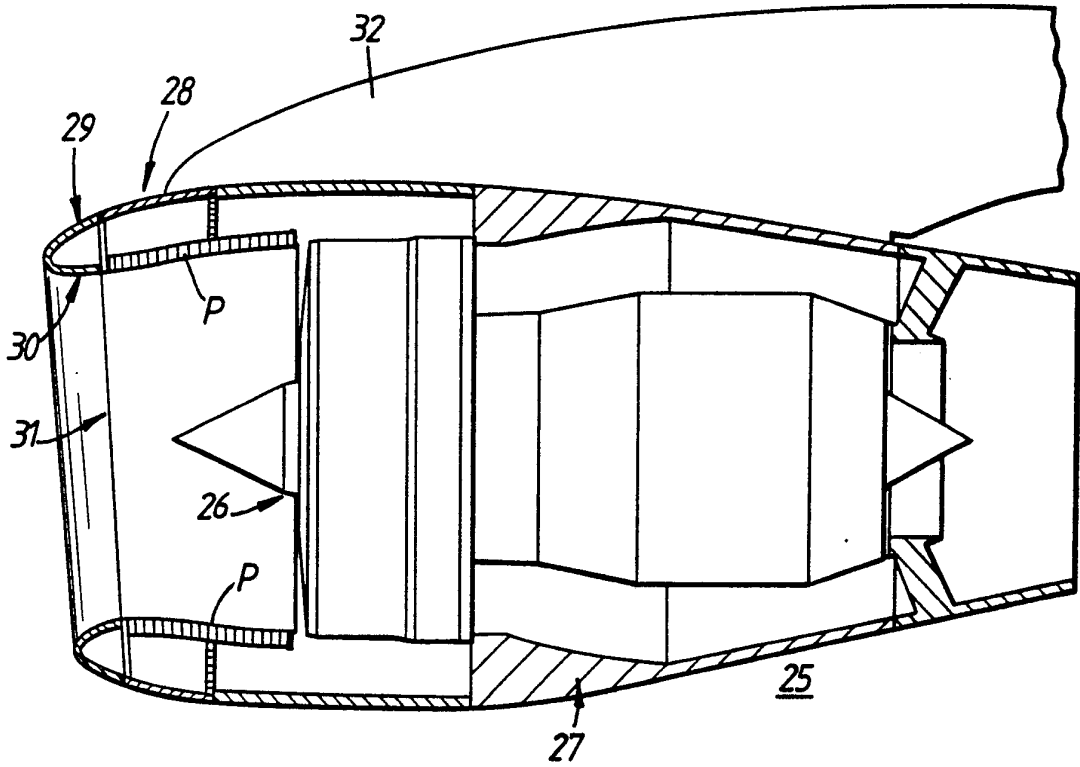

Fig. 6.

INTERNATIONAL SEARCH REPORT

PCT/GB 92/00118

International Application No

I. CLASSIFICATION OF SUBJECT MATTER (if several classification symbols apply, indicate all) ⁶		
According to International Patent Classification (IPC) or to both National Classification and IPC		
Int.Cl. 5 B32B3/12; B32B3/10; G10K11/16		
II. FIELDS SEARCHED		
Minimum Documentation Searched ⁷		
Classification System	Classification Symbols	
Int.Cl. 5	B32B ; G10K	
Documentation Searched other than Minimum Documentation to the Extent that such Documents are Included in the Fields Searched ⁸		
III. DOCUMENTS CONSIDERED TO BE RELEVANT⁹		
Category ^o	Citation of Document, ¹¹ with indication, where appropriate, of the relevant passages ¹²	Relevant to Claim No. ¹³
X	US,A,3 821 999 (GUESS ET AL.) 2 July 1974	1, 11, 24-27
A	see column 1, line 30 - line 53; claim 1; figures 2,3	2-9

X	GB,A,1 347 270 (AMERICAN CYANAMID COMP.) 27 February 1974	1, 2, 24-27
	see column 2, line 45 - line 127; claim 1; figures 1,2	

A	US,A,4 318 453 (ROSE ET AL.) 9 March 1982	22
	see abstract; claims 1,2; figures 1-3	

A	US,A,4 433 021 (RIEL) 21 February 1984	14
	see column 2, line 41 - column 3, line 36; claims 1,3,6,7; figure 1	

	--- -/--	
<p>^o Special categories of cited documents :¹⁰</p> <p>"A" document defining the general state of the art which is not considered to be of particular relevance</p> <p>"E" earlier document but published on or after the international filing date</p> <p>"L" document which may throw doubts on priority claim(s) or which is cited to establish the publication date of another citation or other special reason (as specified)</p> <p>"O" document referring to an oral disclosure, use, exhibition or other means</p> <p>"P" document published prior to the international filing date but later than the priority date claimed</p> <p>"T" later document published after the international filing date or priority date and not in conflict with the application but cited to understand the principle or theory underlying the invention</p> <p>"X" document of particular relevance; the claimed invention cannot be considered novel or cannot be considered to involve an inventive step</p> <p>"Y" document of particular relevance; the claimed invention cannot be considered to involve an inventive step when the document is combined with one or more other such documents, such combination being obvious to a person skilled in the art.</p> <p>"&" document member of the same patent family</p>		
IV. CERTIFICATION		
Date of the Actual Completion of the International Search	Date of Mailing of this International Search Report	
10 APRIL 1992	07.05.92	
International Searching Authority	Signature of Authorized Officer	
EUROPEAN PATENT OFFICE	DERZ T. 	

III. DOCUMENTS CONSIDERED TO BE RELEVANT (CONTINUED FROM THE SECOND SHEET)		Relevant to Claim No.
Category °	Citation of Document, with indication, where appropriate, of the relevant passages	
A	GB,A,2 019 983 (THE BOEING COMP.) 7 November 1979 see page 2, line 8 - line 33; claims 1-9; figures 1-5,9 see claims 1-11 ---	12,13,21
A	US,A,3 819 007 (WIRT ET AL.) 25 June 1974 see column 2, line 37 - line 51; claims 1,5; figure 1 see column 4, line 28 - line 46 ---	5,6,8, 10,11, 12,15, 17,19,20
A	EP,A,0 352 993 (SHORT BROTHERS PLC) 31 January 1990 see column 6, line 5 - line 37; claims 1-3,5-17; figures 3,5	12,13,15
A	g GB-A-22233448 (SHORT BROTHERS PLC) 11-04-1990 cited in the application ---	
P,A	FR,A,2 660 787 (TECHNOLOGIES SPECIALES INGENIERIE - T.S.I.) 11 October 1991 see claims 5-7; figures 1-4 ---	10

**ANNEX TO THE INTERNATIONAL SEARCH REPORT
ON INTERNATIONAL PATENT APPLICATION NO. GB 9200118
SA 55653**

This annex lists the patent family members relating to the patent documents cited in the above-mentioned international search report. The members are as contained in the European Patent Office EDP file on
The European Patent Office is in no way liable for these particulars which are merely given for the purpose of information. 10/04/92

Patent document cited in search report	Publication date	Patent family member(s)	Publication date
US-A-3821999	02-07-74	None	

GB-A-1347270	27-02-74	AU-B- 467747	11-12-75
		AU-A- 3599771	31-05-73
		BE-A- 776852	19-06-72
		CA-A- 956895	29-10-74
		DE-A- 2162984	22-06-72
		FR-A, B 2118168	28-07-72
		NL-A- 7117070	20-06-72

US-A-4318453	09-03-82	DE-A, C 3034196	02-04-81
		FR-A, B 2464930	20-03-81
		GB-A, B 2059341	23-04-81

US-A-4433021	21-02-84	None	

GB-A-2019983	07-11-79	US-A- 4265955	05-05-81
		CA-A- 1117267	02-02-82
		CA-A- 1105394	21-07-81
		DE-A, C 2903024	15-11-79
		FR-A, B 2425118	30-11-79
		GB-A, B 2019767	07-11-79
		JP-A- 54144488	10-11-79
		US-A- 4257998	24-03-81

US-A-3819007	25-06-74	None	

EP-A-0352993	31-01-90	AU-B- 620431	20-02-92
		AU-A- 3988089	19-02-90
		WO-A- 9000968	08-02-90
		GB-A- 2223448	11-04-90
		JP-T- 3501591	11-04-91

FR-A-2660787	11-10-91	None	
