

(19) **DANMARK**

(10) **DK/EP 3392192 T3**



Patent- og
Varemærkestyrelsen

(12) **Oversættelse af
europæisk patentskrift**

-
- (51) Int.Cl.: **B 66 F 11/04 (2006.01)** **B 66 F 17/00 (2006.01)**
- (45) Oversættelsen bekendtgjort den: **2020-02-24**
- (80) Dato for Den Europæiske Patentmyndigheds bekendtgørelse om meddelelse af patentet: **2019-11-20**
- (86) Europæisk ansøgning nr.: **18165068.0**
- (86) Europæisk indleveringsdag: **2018-03-29**
- (87) Den europæiske ansøgnings publiceringsdag: **2018-10-24**
- (30) Prioritet: **2017-04-06 IT 201700038086**
- (84) Designerede stater: **AL AT BE BG CH CY CZ DE DK EE ES FI FR GB GR HR HU IE IS IT LI LT LU LV MC MK MT NL NO PL PT RO RS SE SI SK SM TR**
- (73) Patenthaver: **Manitou Italia S.r.l., Via Cristoforo Colombo 2, Localita' Cavazzona, 41013 Castelfranco Emilia (Modena), Italien**
- (72) Opfinder: **IOTTI, Marco, VIA SIMONE MARTINI 16/3, 42124 REGGIO EMILIA, Italien**
- (74) Fuldmægtig i Danmark: **Plougmann Vingtoft A/S, Strandvejen 70, 2900 Hellerup, Danmark**
- (54) Benævnelse: **LØFTESYSTEM**
- (56) Fremdragne publikationer:
EP-A2- 1 026 120
WO-A1-2012/001353
US-A- 5 992 562
US-A1- 2011 305 552

DESCRIPTION

[0001] The present invention relates to a lifting system provided with a loading platform and destined for use with work machines, such as telescopic lifting machines ("telescopic handlers" or "telehandlers"), aerial platforms or other like machines.

[0002] Loading platforms are known which comprise a bottom plane, able to support the operators and tools, about which side walls are arranged which have the function of preventing accidental falls of the operators or the tools arranged on the bottom plane.

[0003] The platforms are able to be connected to a telescopic lifting arm, with which the work machines are provided, by means of attachment devices.

[0004] The known platforms work very effectively when used for work activities at height which require manual intervention by the operators, possibly with the use of portable tools which, as mentioned, can be easily loaded on the platform.

[0005] However, there are some types of work activities which cannot be carried out using known loading platforms and are therefore performed inefficiently and sometimes in a dangerous way.

[0006] Take, for example, the case of removing asbestos claddings present on the roofs of buildings, by removing the slabs forming the cladding.

[0007] At present, with the purpose of removing the asbestos slabs or another material of a similar kind and/or danger, it is necessary for one or more operators to walk on the roofs in order to work, secured to a safety harness anchored to the roof.

[0008] In fact, if a known platform were to be used for the removal of the slabs, the slabs would have to be loaded onto the bottom plane of the platform, by passing them above the side walls, which would not be practicable and would implicate excessive risks for the operators.

[0009] Another reason for which it is not possible to use known platforms for this type of operation is constituted by the fact that the operators designated for the removal of the slabs normally use protective suits, in which a higher-than-atmospheric pressure is created, with the aim of preventing direct contact with asbestos fibres dispersed in the air.

[0010] As these pressurised suits are voluminous, the operators would suffer from a limited ability to comfortably and effectively manage the lifting and lowering of the platform using the commands provided on-board the platform itself, which commands control the movements of the telescopic arm; clearly, a limited manoeuvring ability would not comply with the safety criteria existing related to the use of this type of tools.

[0011] Therefore, at present, the operators moving on roofs of buildings remove the slabs of the cladding and position them resting on a pallet lifted by a crane or by the forks of a telehandler, which pallet is periodically lowered to the ground surface for the transfer of the removed slabs towards the bed of a truck or the like.

[0012] This solution can be extremely dangerous because if the load of asbestos slabs is not perfectly secured to the pallet, it might slip during the movement and crash down to the ground, with the consequence that the asbestos dust would be dispersed into the atmosphere.

[0013] US5992562 discloses a scissor lift control system including a around control station, located on the base portion of the work platform, and a platform control station. A keyed selector switch is provided at the around control station in order to provide power to either the platform control station or the around control station.

[0014] WO2012001353 discloses a safety device for an aerial lift having operating controls for manoeuvring its basket to a desired location. In detail, this invention includes a passive switch normally closed that allow a flow of electricity which can be cut in order to prevent further movement of the basket.

[0015] EP1026120 describes an aerial platform apparatus having a ground control station and a platform control station. In order to use the platform control station, the operator is required to turn on a key switch, to pull out an emergency stop switch and to depress a foot switch interlock.

[0016] US2011305552 discloses a work platform that can be engaged by a front-end loader bucket.

[0017] The technical task underpinning the present invention is therefore to provide a lifting system which obviates the drawbacks of the prior art.

[0018] This technical task is attained by the lifting system realised according to claim 1.

[0019] Further characteristics and advantages of the present invention will become more apparent from the following indicative, and hence nonlimiting, description of preferred, but not exclusive, embodiments of the system of the invention, as illustrated in the accompanying drawings, in which:

- figures 1 and 2 are axonometric views of the loading platform of the invention, in a first working configuration;
- figures 3 and 4 are two enlarged views of detail K of figure 2, in two different use steps of the platform;
- figure 5 is a side view of a telehandler which bears the platform of figures 1 and 2, in a second working configuration; and
- figures 6 and 7 are axonometric views of the platform, in the second working

configuration, in which the operators are using two different functions of the system of the invention.

[0020] With reference to the above-mentioned figures, reference numeral 1 denotes a loading platform for a telehandler 2, an aerial platform or like work machines.

[0021] The platform 1 of the invention is especially destined to be connected to a lifting arm 21 with which the work machine 2 is provided.

[0022] In the following, for ease of illustration and without departing from the general description, reference will be made to the particular case in which the work machine is a telehandler 2 (see figure 5).

[0023] The platform 1 primarily comprises a bottom plane 10 able to support operators 31, 32 and/or work tools.

[0024] The plane 10 is associated to side walls 11, 12, 13, 14 having the aim of preventing accidental falls of the operators or the load.

[0025] In particular, the plane 10 is preferably quadrangular (for example rectangular) and, therefore, the side walls 11, 12, 13, 14 are located at the perimeter of the plane 10, from which they project to define a sort of open-topped cage.

[0026] The lifting arm 21 is mobile and preferably telescopic; in detail, the arm 21 comprises a plurality of segments, inserted with the possibility of sliding into one another, of which a proximal segment of the arm hinged to the frame of the machine 2 or a rotary turret thereof, and a distal segment which mounts the attachment device 22 for removably attaching the platform 1.

[0027] The platform 1 is provided with a hooking device 15 designed for anchoring to the attachment device 22 of the arm 21, in known ways. Note that the platform 1 can be rotatable with respect to an axis that passes through the hooking device 15; in particular, such a device 15 can include a hinge on which a movement device acts, preferably of a hydraulic type.

[0028] In general, the movements of the arm 21 and the rotation of the platform are preferably performed using hydraulic devices, such as for example hydraulic cylinders, on activation of one or more hydraulic distributors (preferably electro-hydraulic) or other types of activating apparatus, not illustrated as they can be of known type.

[0029] It is possible for the movement devices to be of electromechanical and not hydraulic type.

[0030] The invention includes a first command apparatus 41 arranged on-board the platform 1 and directly activatable by an operator 31, 32 working on the platform 1.

[0031] The first apparatus 41 is able to command the hydraulic distributors (or other activating apparatus), so that they move the arm 21 (and possibly the turret and the rotation joint of the platform 1, if present) in accordance with the commands selected by the operator who is on-board the platform 1.

[0032] The first command apparatus 41 can be fixed or removably applicable to a special seating of the platform 1, provided with connectors and connectable to the control unit of the telehandler 2 by means of a transmission system for transmitting the signals that can be cabled or wireless, for example of the radio frequency type.

[0033] Said seating can be located on the internal side of the most internal side wall 12 of the platform 1, i.e. the side wall connected to the above-mentioned hooking device 15, on the external side.

[0034] The platform 1 can be provided with a control unit of its own to which the first command apparatus 41 is connected; as will be more fully clarified in the following, the invention is configured as a lifting system that includes a processing unit which comprises the control unit of the telehandler 2 and possibly the control unit of the platform 1, if present.

[0035] The first command apparatus 41 is connected to the hydraulic distributors via the control unit of the telehandler 2 and in general via the above-mentioned processing unit, the distributors being hydroelectric devices that can be driven using control signals; basically, it is also possible to have an embodiment of the invention in which the first apparatus 41 is directly connected via cable or via radio to the distributors.

[0036] The first command apparatus 41 comprises an interface, consisting for example of a joystick, buttons, display (including a touchscreen), levers and the like, the activation of which enables the operator 31, 32 to select the commands for movement of the arm 21.

[0037] In more general terms, the interface of the first command apparatus 41 is configured to enable to set or select at least one first position parameter, representative of the movement of the arm 21 both relative to the inclination with respect to the machine frame 2 and relative to the extension and shortening of the arm 21 and, possibly, relative to the rotation of the turret, if present.

[0038] The first apparatus 41 is adapted to generate first command signals, according to the selections made on the relative interface, and the processing unit is adapted to receive the first command signals and is configured to generate and transmit driving signals to the distributors, according to the command signals received.

[0039] The platform 1 of the invention has been designed to switch from a first to a second

working configuration and vice versa.

[0040] In detail, the first working configuration (illustrated in figures 1 and 2) can be a normal use configuration while the second configuration (illustrated in figures 5, 6 and 7) can be employed for special uses, such as for example the removal of asbestos slabs from roof claddings or similar uses.

[0041] In the preferred embodiment, shown in the accompanying figures, at least one 11 of the side walls 11, 12, 13, 14 which border the bottom plane 10 can be mobile between an upright position, defining a first configuration of normal use of the platform 1, and a lowered position, defining a second special use configuration of the platform 1.

[0042] For the sake of precision, in the lowered position of the mobile side wall 11, the platform 1 is in an open configuration which enables the introduction or resting of the material, while in the upright position the platform 1 is closed on all sides.

[0043] The mobile side wall 11 is preferably tiltable, i.e. it can rotate between the upright position in which it is substantially perpendicular to the bottom plane 10, like the other side walls 12, 13, 14, to a lowered position in which it defines a prolongation of the bottom plane 10, and is therefore parallel and/or consecutive to the bottom plane (see figures 6 and 7). Preferably, the mobile side wall 11 is the most external or "frontal" side wall, i.e. the one opposite the rear side wall 12 which bears the hooking device 15.

[0044] In detail, the tiltable side wall 11 is hinged to the bottom 10 at the lower side thereof; auxiliary means to aid the movement of the side wall 11 can be included between the two different positions, which connect the mobile side wall 11 and the bottom 10 of the platform 1, such as for example gas springs, hydraulic cylinders, etc.

[0045] In order to be used together with the bottom 10 as a support for the load, the mobile side wall 11 is provided with a continuous plane, substantially identical to the bottom plane of the platform 1, for example constituted by a slab 110 at least partly made of metal, for example aluminium.

[0046] In still greater detail, the side walls 11, 12, 13, 14 can be of a reticular type (or trellis), with the lattice of the mobile side wall 11 fixedly bearing the above-mentioned continuous plane.

[0047] Further, at the longitudinal ends thereof, the mobile side wall 11 can be provided with two low walls 111, 112 or parapets, to define, in the special use configuration, prolongations of the two fixed side walls 13, 14 arranged between the mobile side wall 11 and the rear side wall 12.

[0048] The two low walls 111, 112 can be hinged to the mobile side wall 11 and be manually fixable in a position in which they are perpendicular to the mobile side wall 11.

[0049] The invention preferably includes a detecting device 51, 52 adapted to check whether the platform 1 is in the first or second working configuration.

[0050] In detail, the detecting device 51, 52 is adapted to check whether said mobile side wall 11 is in the upright position or whether it is in the lowered position.

[0051] In the preferred embodiment, the platform 1 comprises, solidly constrained to the mobile side wall 11, an elongate profiled member 51, for example an elongate curved plate, while the bottom of the platform 1 includes a sensor 52 for detecting the displacement of the profiled member, for example a switch (see figures 3 and 4).

[0052] The curved plate 51 is fixed to the external side of the mobile side wall 11 while the sensor 52 is located below the bottom 10.

[0053] When the mobile side wall 11 moves into the lowered position, the switch 52 is activated and produces a signal representing the fact that the platform 1 is in the open configuration.

[0054] Other embodiments are possible in which the detecting device includes a proximity sensor or in which the microswitch 52 is activated by a mechanism, linkage or mechanical member that is different to the above-mentioned plate 51.

[0055] The system of the invention comprises a second command apparatus, separate from the platform 1 and adapted to enable an operator to select commands, and able to command the above-mentioned activating apparatus according to commands selected by the operator.

[0056] In particular, the second apparatus can be the one located internally of the guide cabin 23 of the work machine 2 and can be like those already used in this type of vehicles and, for this reason, it is not illustrated in the appended figures.

[0057] Alternatively or additionally, the second apparatus can be located externally of the vehicle; for example, the second apparatus can be provided with a radio remote control activatable by an operator from outside the cabin 23 of the machine 2.

[0058] In general, the second command apparatus, like the above-described first apparatus, also comprises an interface, which can include a joystick, buttons, display (including a touchscreen), levers and the like, the activation of which enables the operator to select the commands for movement of the arm 21.

[0059] In the case of using a radio remote control, the control is provided with the interface as described in the foregoing paragraph.

[0060] The interface of the second command apparatus is configured to enable to set or select at least one second position parameter, representative of the movement of the arm 21 both

relative to the inclination with respect to the machine frame 2 and relative to the extension and shortening of the arm 21 and, possibly, relative to the rotation of the turret, if present.

[0061] The second apparatus is adapted to generate second command signals, according to the selections made on the relative interface, and the above-mentioned processing unit is adapted to receive the second command signals and is configured to generate and transmit driving signals to the distributors, according to the second command signals received.

[0062] In practice, both the operators 31, 32 on-board the platform 1 and the operator in the cabin 23, who is also the driver of the vehicle 2, have available command means of the telescopic arm 21 and possibly of the turret and the rotation joint of the platform 1.

[0063] Please note that the invention advantageously enables switching the command of the command apparatus 41 of the platform 1 to the operator in the cabin 23 and vice versa, according to the various working conditions and the different uses of the platform 1, with the aim of always maintaining the highest degree of safety and effectiveness of use.

[0064] The system of the invention includes at least an enabling device 42, 43 provided with an interface selectable by an operator 31, 32 located on-board the platform 1.

[0065] The invention, as shown in the appended figures, preferably includes two enabling devices 42, 43 and, in general, might include a number of enabling devices 42, 43 matching the number of operators 31, 32 that are to work on-board the platform 1.

[0066] The two enabling devices 42, 43 are separated from one another by a distance such as to prevent a same operator 31, 32 from selecting both interfaces of the devices 42, 43; in this way, it is guaranteed that the two operators 31, 32 required for working on-board the platform 1 both act voluntarily on the interface, with the aim of determining which one has command of the arm 21.

[0067] In the example illustrated, the two devices 41, 42 are located at two internal corners of the platform 1, in particular the corners defined at the lateral ends of the side wall 12 opposite the mobile side wall; however, this is not a mandatory solution.

[0068] The interface of the two enabling devices 42, 43 can also comprise common command elements such as buttons, displays, touchscreens, levers, etc...; in the example illustrated in the appended tables of drawings, each enabling device 42, 43 is provided with two buttons 421, 422, 431, 432, the use of which in the invention will be explained in detail in the following.

[0069] As mentioned in the foregoing, the invention includes a processing unit, connected to the first 41 and second command apparatus and to the enabling device(s) 42, 43, as well as to the detecting device 51, 52.

[0070] In general, it is to be noted that, in the present description, the processing unit is

presented divided into distinct functional modules for the sole purpose of describing the functions thereof in a clear and complete manner.

[0071] In practice, the processing unit can be constituted by a single electronic device, including of the type commonly present on this type of machine and platforms, such as the two above-mentioned control units, suitably programmed for carrying out the functions described.

[0072] The different modules can be hardware items and/or software routines that are part of the programmed device.

[0073] These functions may be performed by a plurality of electronic devices over which the aforesaid functional modules can be distributed.

[0074] In general, the processing unit can use one or more microprocessors or microcontrollers for running the instructions contained in memory modules and the aforesaid functional modules may, also, be distributed over a plurality of local or remote computers based on the architecture of the network in which they reside.

[0075] The processing unit is configured for enabling or disabling the command of the activating apparatus by the first 41 or the second command apparatus, according to the selections made on said interface of the enabling device(s) 42, 43.

[0076] Selections of the interface also refers to the choice not to act on the interface; in detail, if the enabling devices 42, 43 are provided with buttons 421, 422, 431, 432 and they are not pressed, then a normal operating condition is selected.

[0077] For the sake of precision, the processing unit comprises an enabling module configured for enabling control of the hydraulic distributors activating the arm 21 alternatively by the command apparatus 41 on-board the platform 1 or by the command apparatus in the cabin, according to what has been selected or not selected on the enabling devices 42, 43. Before specifying further characteristics of the invention and its functioning, it is specified that an aim of the system of the invention is to allow that, during the use of the platform 1 for special activities such as removal of a cladding (for example an asbestos cladding), command of the movement of the arm 21, and therefore the displacing of the platform 1, is entrusted to the operator in the cabin and not the operators 31, 32 on the platform 1.

[0078] In fact, note that during normal use of the platforms, the arm is commanded by the apparatus located on-board the platform, as the operators on the platform have direct vision of the environment surrounding the platform itself, for example the roof of a building, which the operator in the cabin does not have.

[0079] However, as explained during the description of the prior art, for the purposes of removal of asbestos slabs, the operators on the platform often wear a voluminous and uncomfortable pressurised suit which limits their movements and therefore also their ability to

safely command the arm. With this aim in mind, the invention can also include the possibility of an exceptional operating condition in which the command of the arm 21 can be taken over by the operators 31, 32 on-board the platform 1, as is more fully explained in the following.

[0080] Returning to the description of the system of the invention, the processing unit and in particular the enabling module thereof, the module is configured either to enable or disable the command of the activating apparatus by the first 41 or the second command apparatus, also according to the checks carried out by the detecting device 51, 52, i.e. depending on whether the platform 1 is in the normal configuration or in the special use configuration.

[0081] In practice, the processing unit receives the above-described first or second command signals, the configuration signals from the switch 52 (or other device suitable for the purpose) and enabling signals from the enabling devices 42, 43 and, according to these, processes driving signals which are transmitted to the distributor(s) which activate the cylinders of the arm 21.

[0082] As explained above, in the preferred embodiment of the invention, each enabling device 42, 43 includes buttons 421, 422, 431, 432, preferably two in number.

[0083] Pressing on a first button 421, 431 selects a first enabling condition while pressing on the second button 422, 432 selects a second enabling condition, alternative to the first; in practice, on the basis of the pressure exerted on the buttons of the enabling devices 42, 43 the command of the arm 21 can be established or switched by the command apparatus 41 of the platform 1 or by the command apparatus separate from the platform 1 and located in the cabin 23.

[0084] Preferably, the invention envisages that the processing unit enables control of the arm 21 by the apparatus in the cabin, disabling the apparatus on the platform 1, if both the platform 31, 32 operators have contemporaneously pressed or continue to press the first button 421, 431 of the relative enabling device 42, 43.

[0085] In general terms, the interface of the enabling device 42, 43, however realised, is adapted to enable an operator 31, 32 to select at least a first enabling condition; when said first enabling condition is selected, the enabling module of the processing unit enables the second command apparatus (separate from the platform 1) to command the activating apparatus (constituted by one or more distributors) and at the same time disables the first command apparatus 41.

[0086] If two enabling devices 42, 43 are present, the enabling module is configured to enable the second command apparatus to command the activating apparatus and to disable the first command apparatus 41, once said first enabling condition is selected in both the enabling devices 42, 43 located on-board the platform 1.

[0087] Note that the enabling module is preferably configured for enabling the first command

apparatus 41 to command the activating apparatus, only if the detecting device 51, 52 has checked that the platform 1 is in the second working configuration, i.e. the one for special use of the platform. When the second enabling condition is selected, the enabling module enables the first command apparatus 41 to command the activating apparatus while disabling the second command apparatus.

[0088] The functioning of the invention is explained in the following.

[0089] When in the normal use configuration, illustrated in figures 1 and 2, with the mobile side wall 11 upright, the platform 1 of the invention can be used like any other platform.

[0090] For the sake of precision, the command of the arm 21 is exclusively entrusted to the operators 31, 32 on-board the platform 1 who use the joystick and the buttons or other interface means of the above-mentioned first command apparatus 41.

[0091] If the platform 1 is to be employed for special uses, such as the removal of asbestos roof claddings, before use the platform 1 must be opened, i.e. the mobile side wall 11 must be tilted, creating a lengthened bottom plane 10, 110 at the base of the platform 1.

[0092] As can be seen in figures 3 and 4, the opening of the mobile side wall 11 activates the switch 52 which transmits the above-mentioned configuration signal to the processing unit, which thus receives the information that the platform 1 is in the working configuration for special uses.

[0093] At this point, the operators 31, 32, represented in a stylised way in the figures, board the platform 1 and move to a respective enabling device 42, 43, in order for both of them to press the above-mentioned first button 421, 431, which selects the first enabling condition.

[0094] At this point, the processing unit disables the use of the first command apparatus 41, authorising only the second command apparatus located in the cabin only to move the lifting arm 21 on activation of the distributor or the hydraulic distributors.

[0095] When the platform 1 has reached the working location, for example on a roof, the two operators 31, 32 can remove the claddings and bring them on-board the platform 1.

[0096] Note that the platform 1 of the invention further comprises two hooking rods 61, 62, preferably curved in a hook shape, to which it is possible to anchor retaining cables (not illustrated for the sake of clarity in the figures) connected to the suits or to a harness worn by the operator 31, 32 working on the platform 1.

[0097] The rods 61, 62 are preferably located at the opposite corners flanking the fixed side wall 12 opposite the mobile side wall 11; the rods 61, 62 prolong the side walls 11, 12, 13, 14 from above and can be removably coupled to attachment members mounted on the side walls and maintained in position by special holes and split pins or like releasable joining means.

[0098] It can also be envisaged that the rods 61, 62 can be blocked in various angular positions to facilitate use thereof.

[0099] Once a load of asbestos slabs has been accumulated on the platform 1, the operators 31, 32 newly approach the enabling devices 42, 43 and both press the first button 421, 431 to enable the operator in the cabin to return the platform 1 to the ground surface, together with the material to be unloaded.

[0100] In a case in which the operators 31, 32 are at height and for some reason the cabin operator is not able to activate the arm 21, for example because he has left the cabin, it is possible for the platform 1 to be lowered and the two operators 31, 32 to the ground surface in the following way.

[0101] One of the platform 1 operators 32 goes to one of the enabling devices 42, 43 and presses the second button 432, 422.

[0102] The processing unit then authorises the first command apparatus 41 to control the movement of the arms 21, enabling the second operator 31 to manoeuvre the platform 1 to bring it and its occupant operators 31, 32 to the ground surface.

[0103] It can be envisaged that the processing unit interrupts the disabling of the use of the first command apparatus 41 as long as the second button 432, 422 continues to be pressed.

[0104] In this way, there is the certainty that the operator 31 positioned at the commands can move the platform 1 only if the other operator 32 is safe and is not on the edge of the loading plane 10, 110 defined by the free end of the mobile side wall 11.

REFERENCES CITED IN THE DESCRIPTION

This list of references cited by the applicant is for the reader's convenience only. It does not form part of the European patent document. Even though great care has been taken in compiling the references, errors or omissions cannot be excluded and the EPO disclaims all liability in this regard.

Patent documents cited in the description

- [US5992562A](#) **[0013]**
- [WO2012001353A](#) **[0014]**
- [EP1026120A](#) **[0015]**
- [US2011305552A](#) **[0016]**

Patentkrav

1. Løftesystem til arbejdsmaskiner (2), omfattende:

5 en læsseplatform (1) som kan understøtte operatører (31, 32) og/eller værktøj;
en bevægelig løftearm (21) på hvilken platformen (1) er monteret;
mindst et betjeningsapparat til at bevæge armen (21);
mindst et første styringsapparat (41), indrettet på platformen (1) og
10 indrettet til gøre det muligt for en operatør (31, 32) at vælge kommandoer, idet det første apparat (41) kan styre betjeningsapparatet i overensstemmelse med kommandoer valgt af operatøren (31, 32);
mindst et andet styringsapparat, adskilt fra platformen (1) og indrettet til at gøre det muligt for en operatør at vælge kommandoer, og som kan styre betjeningsapparatet i overensstemmelse med kommandoer valgt af
15 operatøren;
mindst en aktiveringsindretning (42, 43) forsynet med en grænseflade (421, 422, 431, 432) som kan vælges af en operatør (31, 32); og
en behandlingsenhed konfigureret til at aktivere eller deaktivere kommandoen fra betjeningsapparatet med det første (41) eller det andet
20 styringsapparat, i overensstemmelse med valgene foretaget på aktiveringsindretningens (42, 43) grænseflade; **kendetegnet ved, at** aktiveringsindretningen (42, 43) er placeret på platformen (1);
idet aktiveringsindretningens (42, 43) grænseflade er indrettet til at gøre det muligt for en operatør (31, 32) at vælge mindst en første
25 aktiveringstilstand, idet behandlingsenheden omfatter et aktiveringsmodul konfigureret til at aktivere det andet styringsapparat for at styre betjeningsapparatet og til at deaktivere det første styringsapparat (41), når den første aktiveringstilstand vælges.

30 **2.** System ifølge det foregående krav, omfattende mindst to aktiveringsindretninger (42, 43).

- 3.** System ifølge mindst et af de foregående krav, hvor platformen (1) er indrettet til at passere fra en første til en anden driftskonfiguration og vice versa.
- 4.** System ifølge det foregående krav, hvor platformen (1) omfatter en bundflade (10) og en flerhed af sidevægge (11, 12, 13, 14), hvoraf mindst en sidevæg (11) er bevægelig mellem en oprejst position, som definerer en første konfiguration af normal anvendelse af platformen (1), og en nedsænket position, som definerer en anden speciel anvendelseskonfiguration af platformen (1).
- 10 **5.** System ifølge det foregående krav, hvor, i den nedsænkede position deraf, definerer den bevægelige sidevæg (11) en forlængelse af bundfladen (10).
- 6.** System ifølge mindst et af kravene 3 til 5, omfattende mindst en detekteringsindretning (51, 52) indrettet til at tjekke, om platformen (1) er
15 placeret i den første eller den anden driftskonfiguration, idet behandlingsenheden er konfigureret til at aktivere og deaktivere kommandoen fra betjeningsapparatet med det første (41) eller det andet styringsapparat, også i overensstemmelse med tjekkene udført med detekteringsindretningen (51, 52).
- 20 **7.** System ifølge mindst et af kravene fra 4 til 6, hvor detekteringsindretningen (51, 52) er indrettet til at tjekke, om den bevægelige sidevæg (11) er i den oprejste position, eller til at tjekke om den bevægelige sidevæg (11) er i den nedsænkede position, eller begge.
- 25 **8.** System ifølge krav 2, hvor aktiveringsmodulet er konfigureret til at aktivere det andet styringsapparat for at styre betjeningsapparatet og til at deaktivere det første styringsapparat (41), når den første aktiveringstilstand vælges i begge aktiveringsindretningerne (42, 43).
- 30 **9.** System ifølge mindst et af kravene 2 til 8, hvor de to aktiveringsindretninger (42, 43) er adskilt fra hinanden med en afstand for at forhindre, at den samme operatør (31, 32) vælger begge grænseflader af indretningerne (42, 43).
- 10.** System ifølge mindst et af de foregående krav, hvor aktiveringsindretningens
35 (42, 43) grænseflade er indrettet til at gøre det muligt for en operatør (31, 32) at

vælge en anden aktiveringstilstand, idet behandlingsenheden omfatter et aktiveringsmodul konfigureret til at aktivere det første styringsapparats (41) til at styre betjeningsapparatet og til at deaktivere det andet styringsapparat, når den anden aktiveringstilstand vælges.

5

11. System ifølge mindst et af kravene fra 6 til 10, hvor aktiveringsmodulet er konfigureret til at aktivere det første styringsapparat (41) til at styre betjeningsapparatet, efter det er tjekket med detekteringsindretningen (51, 52), at platformen (1) er i den anden driftskonfiguration.

10

12. System ifølge mindst et af de foregående krav, hvor det andet styringsapparat er forsynet med en radiofjernstyring.

13. Arbejdsmaskine (2) omfattende et system ifølge mindst et af de foregående krav og omfattende et førerhus (23), hvor det andet styringsapparat er placeret.

15

DRAWINGS

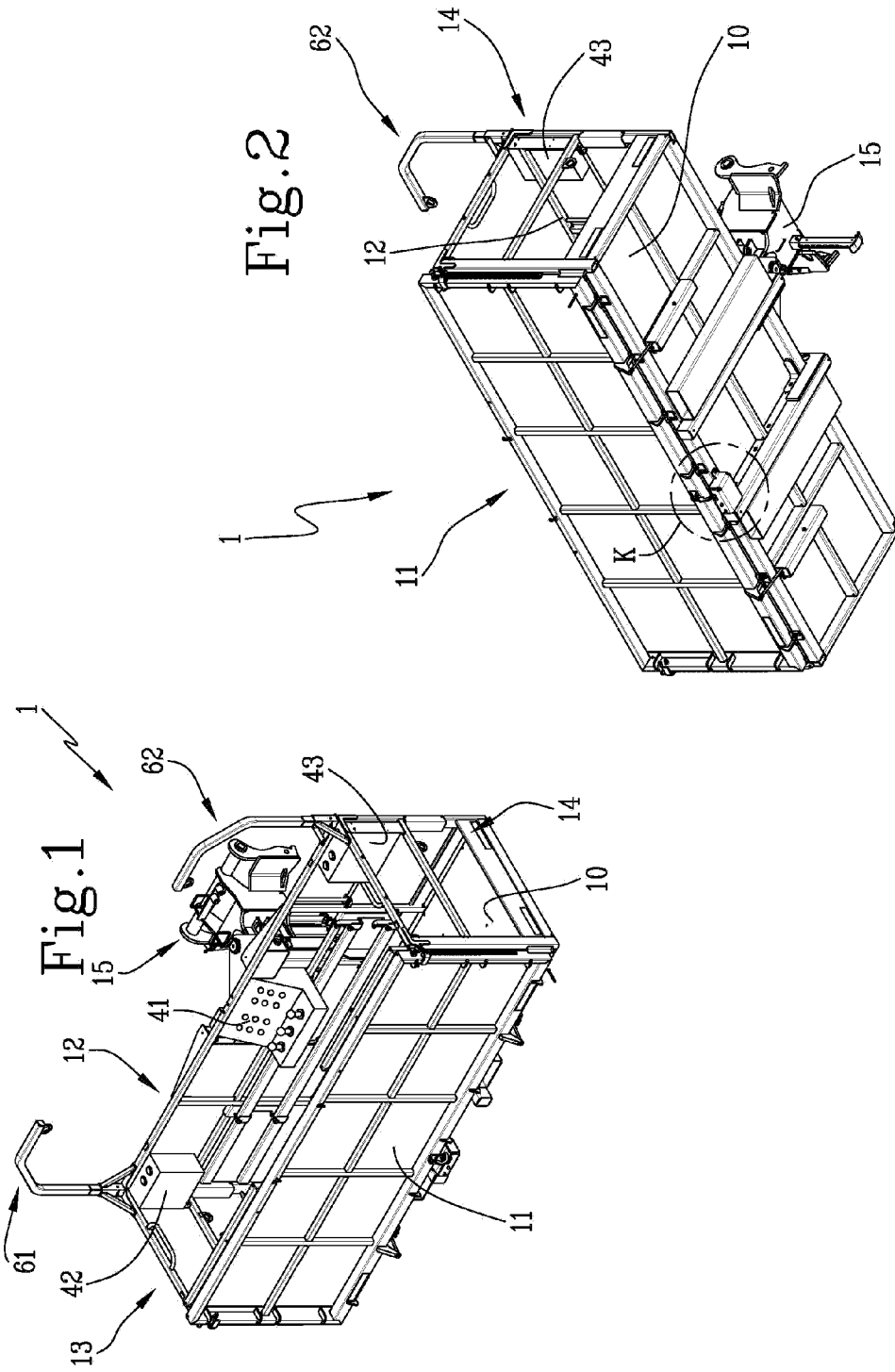

Fig.3

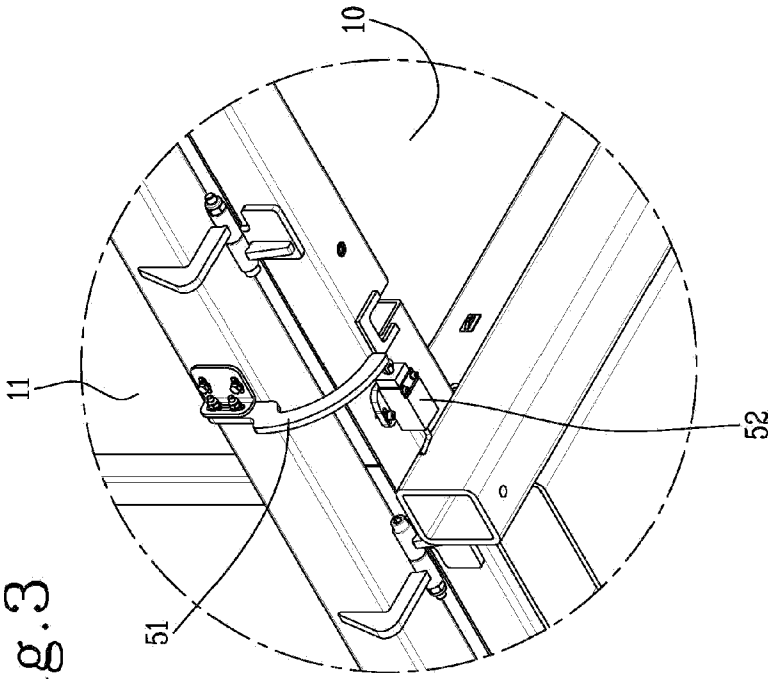
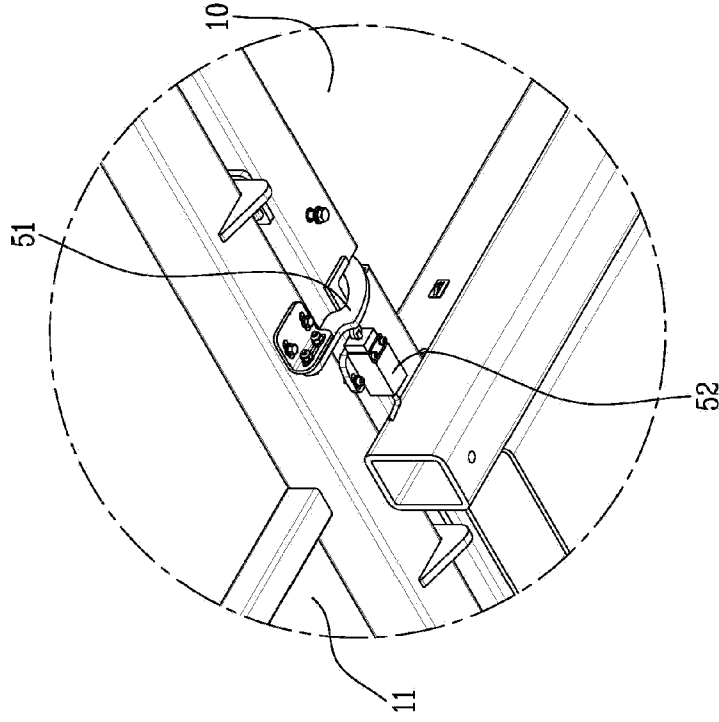

Fig.4



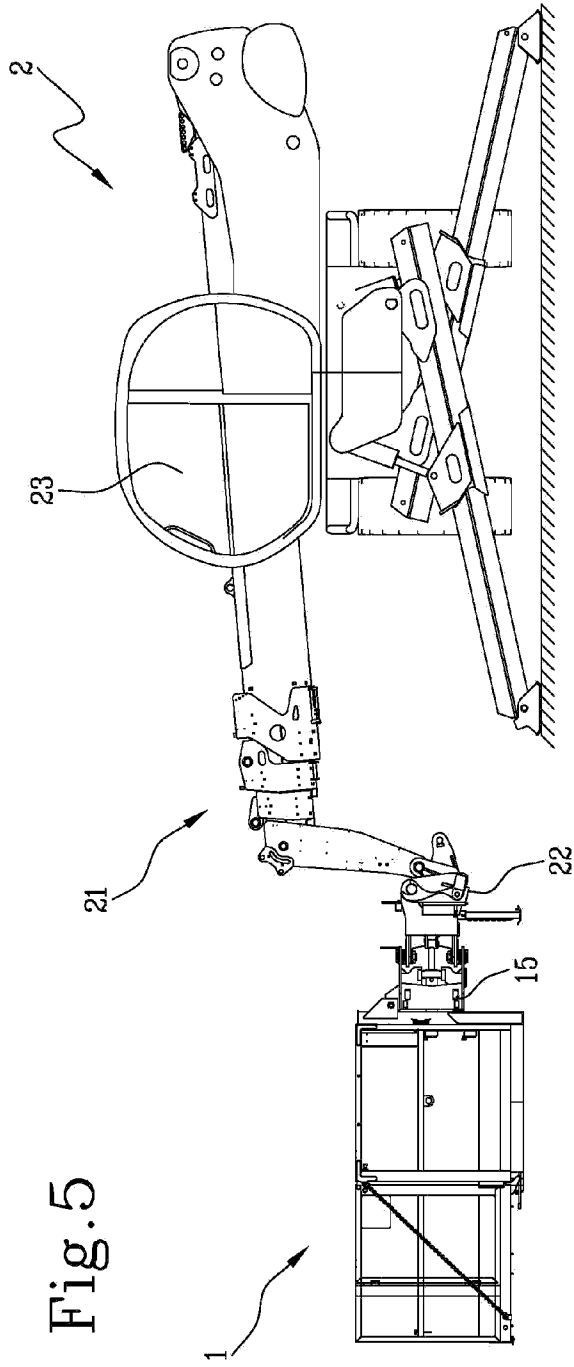

Fig. 5

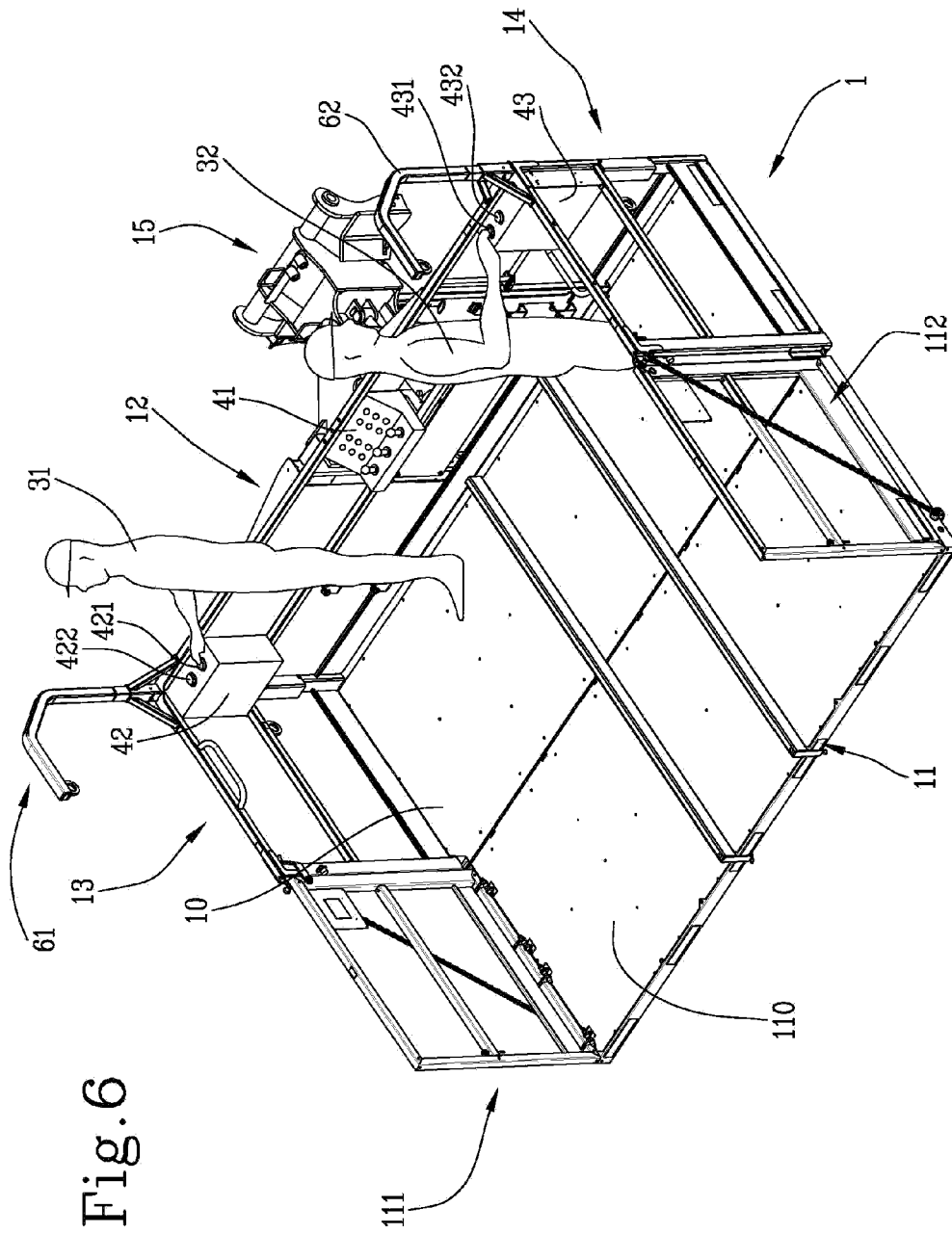

Fig. 6

