



Sept. 19, 1967

J. W. RYAN ET AL  
TOY POP GUN HAVING AN AIR PUMP WITH A RESILIENTLY  
FLEXIBLE MOVABLE CHAMBER CLOSURE MEMBER

3,342,171

Filed Feb. 15, 1965

3 Sheets-Sheet 2

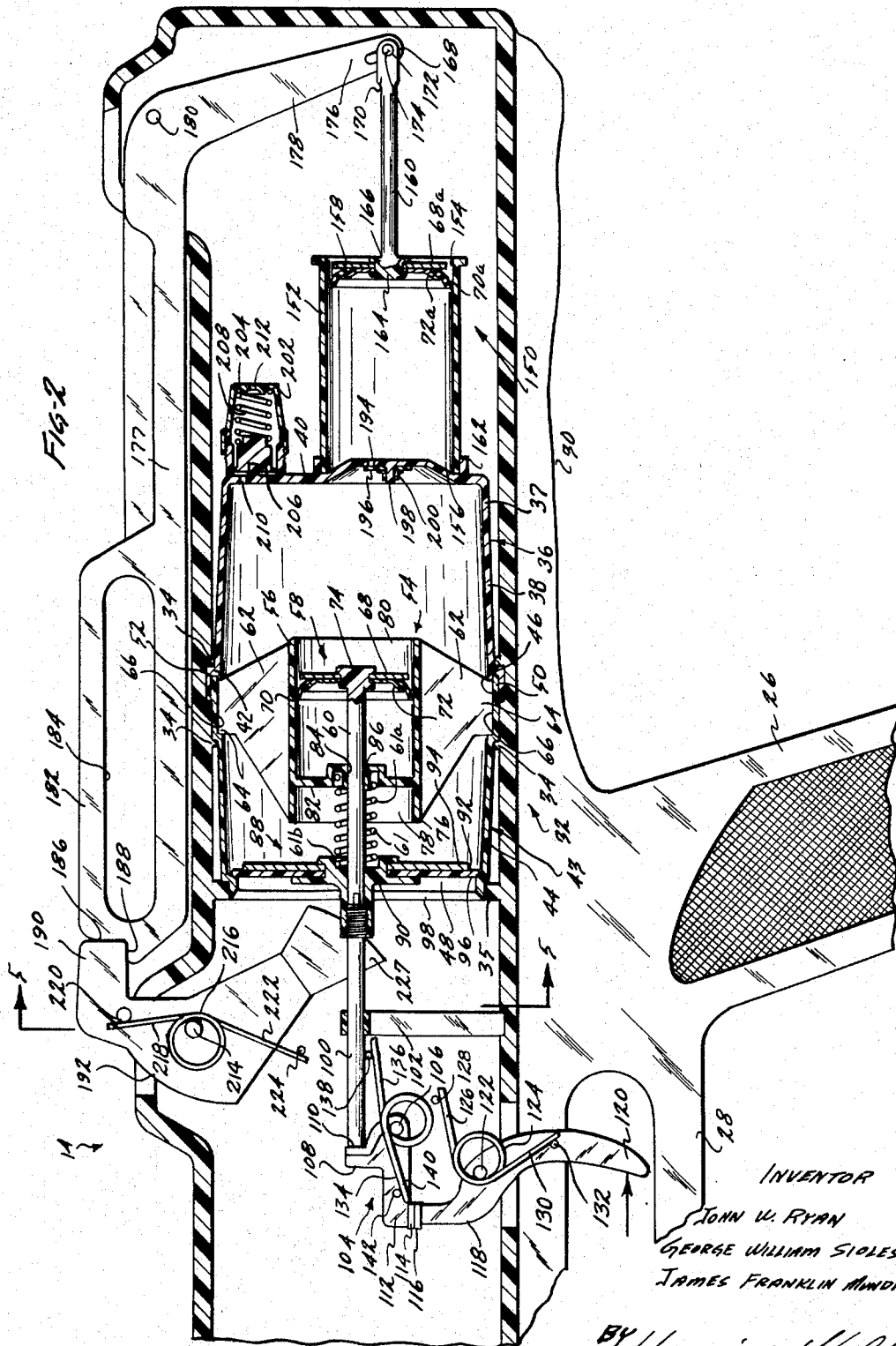

INVENTOR  
JOHN W. RYAN  
GEORGE WILLIAM STILES  
JAMES FRANKLIN MUNDAY

BY *Herbert Wald*  
ATTORNEYS

Sept. 19, 1967

J. W. RYAN ETAL

3,342,171

TOY POP GUN HAVING AN AIR PUMP WITH A RESILIENTLY FLEXIBLE MOVABLE CHAMBER CLOSURE MEMBER

Filed Feb. 15, 1965

3 Sheets-Sheet 3

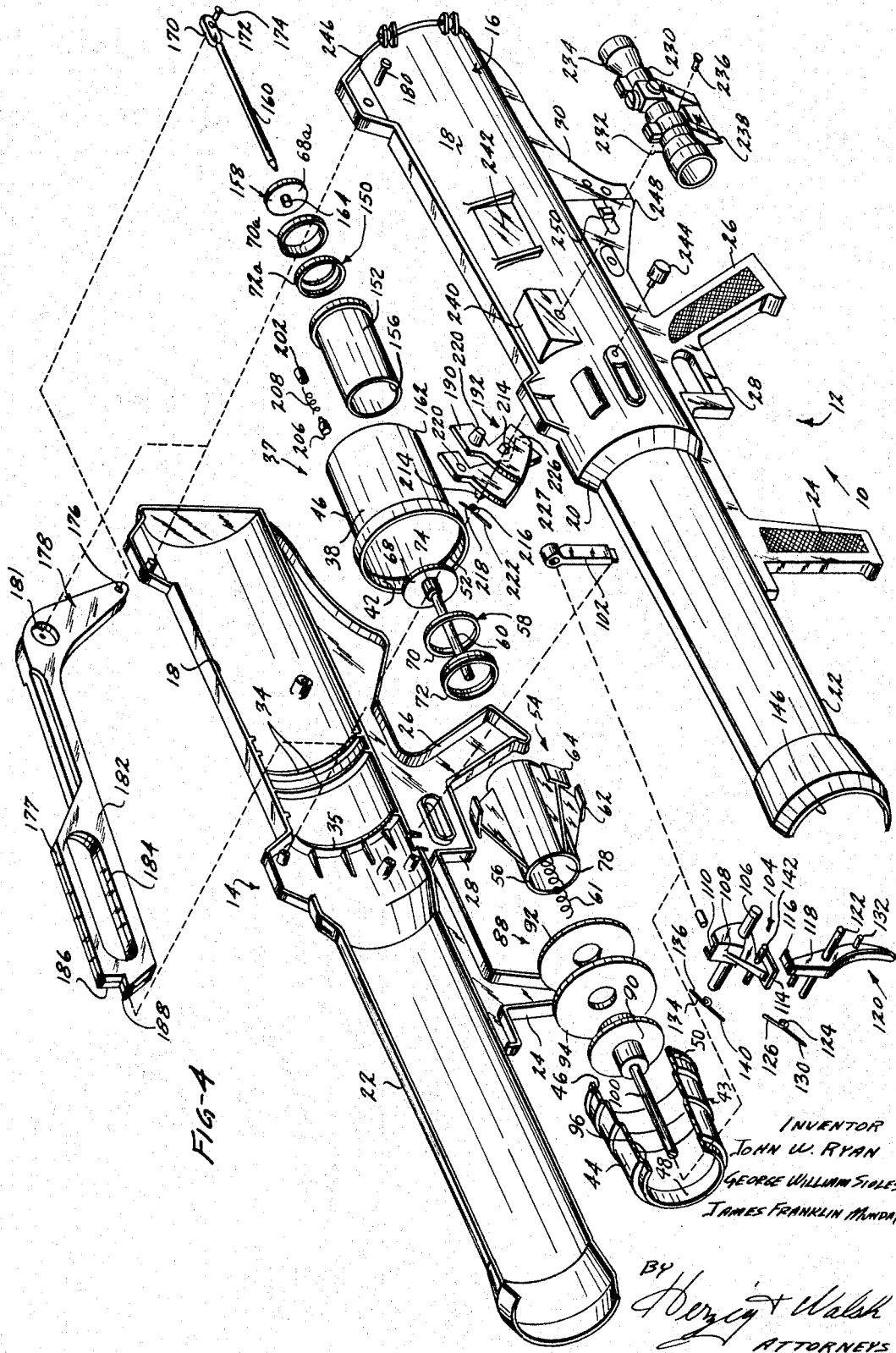

1

2

3,342,171

**TOY POP GUN HAVING AN AIR PUMP WITH A RESILIENTLY FLEXIBLE MOVABLE CHAMBER CLOSURE MEMBER**

John W. Ryan, Bel Air, George William Sioles, Palos Verdes Estates, and James Franklin Munday, South Gate, Calif., assignors to Mattel, Inc., Hawthorne, Calif., a corporation of California

Filed Feb. 15, 1965, Ser. No. 432,730

6 Claims. (Cl. 124—1)

**ABSTRACT OF THE DISCLOSURE**

A toy gun having a chamber and pump to compress air in the chamber, the chamber has an outlet opening and a piston-like member having a resilient periphery sealing the opening to prevent escape of air pressure. Trigger means hold the piston-like member in sealing position but when actuated permits the pressure in the chamber to force the member to pop out through the opening and produce a gun simulating sound. A lever is provided for repositioning the member in the chamber and dashpot means in the chamber are connected to the member for restraining its outward movement and for at least partially resetting the member in the chamber.

This invention relates to a toy gun and more particularly to a new and useful toy gun of the pop gun type.

*Background of the invention*

A number of types of pop guns are, of course, known. Such guns produce a sound when they are fired and may be of any one of a wide variety of different constructions. Most of these prior art pop guns are designed so that air under pressure may be suddenly released.

The sound comes from some of these prior art pop guns by bursting a paper when the air is released. Other prior art pop guns are designed so that the air causes a cork or the like to be fired.

While generally satisfactory, these prior art pop guns do have certain disadvantages. One disadvantage with the type which bursts a paper resides in the fact that the rolls of paper must be replenished periodically. One disadvantage with the guns which shoot a cork resides in the fact that the cork often becomes lost.

A general disadvantage of many guns which create noise by bursting materials or otherwise obtaining a nearly instantaneous release of air is that the abrupt release of air tends to create both an undesirably high pitch of noise and a steep and sharp rise in air pressure which increases the possibility, in children's play, of damage to a child's ear.

*Summary of the invention*

In view of the foregoing factors and conditions characteristic of toy pop guns, it is a primary object of the present invention to provide a new and useful toy gun not subject to the disadvantages enumerated above and having accumulator means especially designed for firing the gun efficiently, safely and economically.

Another object of the present invention is to provide a toy pop gun of the type described which shoots a vortex of air when actuated.

Yet another object of the present invention is to provide a new and useful toy gun having a separate air pump which supplies air under pressure to an accumulator to pressurize a large diaphragm which pops through an opening in the end of the accumulator when the gun is triggered.

A further object of the present invention is to provide a toy gun of the type which pops a diaphragm through an opening with a dash pot or damper which controls the

action of the diaphragm after it passes through the opening.

According to the present invention, a toy, recoilless rifle is provided with an accumulator having an open end in which a large diaphragm is mounted on a rod which is connected to a piston in a dash pot. The rod is engaged by the gun's trigger mechanism.

An air pump is connected to the accumulator for supplying air under pressure thereto which builds up to a predetermined amount governed by a safety valve provided on the accumulator. When the trigger is squeezed to release the rod, the air in the accumulator not only forces the diaphragm out the open end thereof with a loud bang, but also shoots a vortex of compressed air which may be directed at a suitable target. Although the back pressure on the piston in the dash pot usually draws the diaphragm back into the accumulator to recock the gun, a manual recocking lever is also provided. This lever must be actuated to move the diaphragm back into the accumulator before the air pump can be actuated. Thus, a child-user of the gun is assured that it is always cocked before the pump is used to pressurize the accumulator.

The features of the present invention which are believed to be novel are set forth with particularity in the appended claims. The present invention, both as to its organization and manner of operation, together with further objects and advantages thereof, may best be understood by reference to the following description, taken in connection with the accompanying drawings in which like reference characters refer to like elements in the several views.

In the drawings:

FIGURE 1 is a perspective view of a toy gun of the present invention;

FIGURE 2 is an enlarged cross-sectional view taken along line 2—2 of FIGURE 1;

FIGURE 3 is an enlarged, partial cross-sectional view showing a diaphragm and associated parts of the gun in solid line and broken line positions illustrating the before-firing and after-firing conditions, respectively;

FIGURE 4 is an enlarged, exploded perspective view of the gun of FIGURE 1; and

FIGURE 5 is an enlarged cross-sectional view taken along line 5—5 of FIGURE 2.

*Description of a preferred embodiment*

Referring again to the drawings, a gun or rifle constituting a presently preferred embodiment of the invention, generally designated 10, includes a housing 12 having right and left hand housing halves 14 and 16, respectively. The housing 12 may be made from any suitable material by any suitable manufacturing method and is shown herein for purposes of illustration, but not of limitation as, having an injection-molded, high-impact styrene structure wherein each housing half is molded separately.

The housing 12 includes a mechanism chamber 18 which is joined by a frusto-conical transition section 20 to a cylindrical barrel 22. The housing 12 also includes a forward grip 24, a rear grip 26, a trigger guard 28 and a shoulder rest 30. A recoilless firing mechanism 32 is mounted in the mechanism chamber 18 and is retained in position therein by a pair of spaced, annular ribs 34 and a forward annular rib 35.

The firing mechanism 32 includes a cylindrical accumulator 36 comprising a rear housing half 37 having an encompassing side wall 38, a closed end wall 40, and an open end 42. The accumulator 36 also comprises a front housing half 43 having an encompassing side wall 44, and open ends 46 and 48, respectively.

The rear housing half 37 is joined to the front housing half 43 by engaging an annular tongue 50 provided at the open end 46 with an annular groove 52 provided on the open end 42.

3

A dash pot or damper 54 which comprises a cylinder 56, a piston 58, a piston rod 60 and a seal spring 61, is mounted in the accumulator 36 by a plurality of brackets 62 having arcuate flanges 64 which engage recesses 66 provided in the encompassing side wall 44 of the accumulator half 43. The piston 58 includes a piston back 68, a flexible piston cup 70 and a piston plate 72 which are clamped together by a head 74 formed on the end of the piston rod 60. The cylinder 56 includes an encompassing side wall 76 and open ends 78 and 80. An annular partition 82 is mounted in the cylinder 56 intermediate the ends 78 and 80 and is provided with a bore 84 in which the piston rod 60 is slideably mounted with sufficient clearance to provide an air-bleed passageway 86 between the piston rod 60 and the partition 82. A diaphragm assembly 88 is affixed to the piston rod 60 by a hub 90 which clamps a diaphragm back or plate 92 and a flexible diaphragm member 94 together. The diaphragm 94 abuts an annular shoulder 96 provided in the open end 48 of the accumulator 36 and is adapted to be forced therethrough with a loud bang when the gun 10 is fired in a manner to be hereinafter described. The seal spring 61 has one end 61a bearing against partition 82 and another end 61b bearing against the hub 90 to normally seat the diaphragm against the shoulder 96. Although other dimensions will manifest themselves, it has been found satisfactory for good results to employ an outside diameter for the diaphragm back-up plate 92 which is smaller than the inside diameter of the open end 48 by an amount equal to  $\frac{1}{2}$  the thickness of the diaphragm 94. Such dimensioning causes the diaphragm 94 to flex as shown in broken lines in FIGURE 3 as it passes through the open end 48 to the exterior of the accumulator 36. A chamfer 98 is provided on the inner surface of the open end 48 to facilitate reinsertion of the diaphragm 94 into the accumulator 36. The end 100 of the rod 60 which is remote from the head 74 is slideably mounted in a fixed bearing 102 provided in the housing 12.

The diaphragm assembly 88, which is actually a movably mounted closure member is retained in position within the accumulator 36 when it is pressurized, in a manner to be hereinafter described, by the abutment of the end 100 of rod 60 against a firing lever 104 which is pivotally mounted in the housing 12 by a pin 106. The firing lever 104 includes a first end 108 having a channel 110 engageable with the end 100 of the rod 60 and a second end 112 having a flat face 114 engageable with a similar face 116 provided on the end 118 of a trigger 120. The trigger 120 is pivotally mounted by a pin 122 in the housing 12 and is biased to the position shown in FIGURE 2 by a torsion spring 124 having one arm 126 engaging a fixed pin 128 provided in housing 12 and a second arm 130 engaging a pin 132 provided on the trigger 120. When the trigger 120 is moved in a counter-clockwise direction, as viewed in FIGURE 2, the faces 114 and 116 become disengaged permitting the firing lever 104 to swing in a counterclockwise direction from the force imparted thereto by the urging of the diaphragm assembly 88 to the left under the influence of the pressure in the accumulator 36. The lever 104 is returned to a position for engagement with the trigger 120 by a spring 134 having one arm 136 engaging a fixed pin 138 provided in housing 12 and a second arm 140 engaging a pin 142 which is affixed to the lever 104.

Movement of the diaphragm assembly 88 through the open end 48 releases the accumulated pressure in the accumulator 36 into the barrel 22 from whence it flows out the open end 146 thereof with considerable force in the form of a vortex. The diaphragm assembly 88 is arrested by the damper 54 due to the resistance created by bleeding air through the bleed passageway 86. The air pressure which builds up between partition 82 and piston 58 is ordinarily sufficient to force the diaphragm 94 back into the accumulator 36 through the open end 48, thereby recocking the gun 10. Recocking means, to be hereinafter

4

described, is also provided to assure that the gun 10 is recocked should the back-pressure on piston 58 be insufficient to automatically recock the gun 10.

The accumulator 36 is pressurized by a pump 150 which may be made of any suitable material, such as styrene and which comprises a pump cylinder 152 having open ends 154 and 156, a piston 158 and a piston rod 160. The open end 156 is secured to the end wall 40 of the accumulator 36 by an annular flange 162 which encompasses the cylinder 152 and which may be bonded thereto by solvent welding or the like. For manufacturing convenience, the piston 158 may be identical in size to the piston 58 and comprises a piston back 68a, a piston cup 70a and a piston plate 72a. The parts 68a, 70a and 72a are clamped together by a head 164 provided on the end 166 of the piston rod 160. The other end 168 of rod 160 includes a flat tang 170 which is provided with an aperture 172 in which a rivet 174 is mounted and held captive between the ends 176 of the halves 177 of a pump handle 178. The pump handle 178 is pivotally mounted in the housing 12 by a pin or rivet 180 which passes through an aperture 181 provided in the handle 178 between the end 176 and its other end 182. The end 182 of the handle 178 is provided with a hand-grip portion 184 and a notched portion 186 which forms a shoulder 188 engageable by an end 190 of a recock lever 192, which locks the handle 178 against rotation about the pin 180. The handle 178, in its locked position, serves as a carrying handle for the gun 10.

When the recock lever 192 is released from engagement with the shoulder 188, the lever 178 may be swung upwardly and then downwardly to reciprocate the piston 158, whereby air under pressure is forced into the accumulator 36 through an aperture 194 and a check valve 196 provided in the end wall 40. The check valve 196 is secured to the end wall 40 by engaging a boss 198 provided thereon and is retained in position over the aperture 194 by a snap ring or eyelet 200. The check valve 196 is of a flexible nature so that it will flex inwardly toward the inside of the accumulator 36 to permit air under pressure to flow therein but will prevent back flow through the aperture 194 by being pressed tightly against the wall 40 by the pressure in the accumulator 36. The amount of pressure which can be built up in the accumulator 36 is controlled by a relief valve 202 comprising a styrene valve cover 204, a valve piston 206 and a valve spring 208. The spring 208 biases the piston 206 into engagement with the wall 40 to seal an aperture 210 provided therein. The spring 208 is designed to exert a predetermined force on the valve piston 206 which is overcome when the pressure in the accumulator 36 exceeds a predetermined amount thereby forcing the piston 206 to the right, as viewed in FIGURE 2, unseating the piston 206 and permitting air under pressure to flow through the aperture 210 and leave the valve 202 through an aperture 212 provided in the housing 204.

The recock lever 192 assures that the diaphragm assembly 88 is always moved back into the accumulator 36 after the gun 10 is fired and is pivotally mounted in the housing 12 by a pin 214. The recock lever 192 is biased against the shoulder 188 by a spring 216 having an arm 218 engaging one of a pair of pins or knobs 220 mounted on the lever 192 and an arm 222 which engages a fixed pin 224 provided in the housing 12. The end 226 of the lever 192 includes an offset portion 227 which engages the diaphragm assembly 88 to move it back into the accumulator 36 when recock lever 192 is swung in a counterclockwise direction to release pump handle 178 by grasping the knobs 220.

A simulated gun sight 230 comprises injection-molded high-impact styrene housing halves 232 and 234 and is connected to the housing 12 by a pin 236 which clamps the leg 238 of each half 232 and 234 to a prism-like member 240 mounted on the housing half 16 of gun 10.

The appearance of the gun 10 is enhanced by providing

it with a number of simulated features such as a cheek pad 242, a cocking-bolt knob 244 and a hinged end plate 246. The plate 246 gives the gun 10 the illusion of being a bazooka-type weapon, a rocket launcher or the like. A simulated swingable member 248 is also provided so that a child-user of the gun 10 may pretend that he is field stripping the gun by pretending to release the simulated member 248 with a simulated release button 250.

In use, the recock lever 192 may be actuated to release pump handle 178 so that the pump 150 may be actuated to build up the predetermined pressure in the accumulator 36 which will be found to be sufficient when the relief valve 202 opens. This accumulated pressure will force the diaphragm 94 through the open end 48 with a loud bang when the trigger 120 is squeezed to release the firing lever 104. Air in the accumulator 36 rushes out the open end 48 into the rifle barrel 22 and out through the end 146 thereof in the form of a vortex which will travel several yards and which may be employed to hit a target with a fair amount of accuracy. This release, which is more nearly valve-like than that obtained, for example, by bursting certain materials, produces an equally satisfactory loudness of noise with a relatively slower pulse of air pressure, thereby obtaining a generally lower pitch which more nearly simulates a weapon noise for children and a lower peak pressure less likely to cause ear damage. The damper 54 arrests the diaphragm 94 by compressing air between partition 82 and piston 58 so that a back pressure is built up therebetween. This back pressure urges the diaphragm 94 back through the open end 48 into the accumulator 36. If this back pressure fails to reposition the diaphragm 94 within the accumulator 36, the recock lever 192 will force the diaphragm 94 back into the accumulator 36 when the lever 192 is swung in a counterclockwise direction to release the pump lever 178 so that it may again be manipulated to actuate the pump 150.

While the particular toy gun herein shown and described in detail is fully capable of attaining the objects and providing the advantages hereinbefore stated, it is to be understood that it is merely illustrative of the presently preferred embodiment of the invention and that no limitations are intended to the details of construction or design herein shown other than as defined in the appended claims.

What is claimed is:

1. A toy gun comprising: means defining a chamber; pump means for compressing air in said chamber to a superatmospheric pressure; an outlet opening from said

chamber; a closure member movably mounted in said chamber and having a resiliently flexible peripheral portion, larger than said opening, sealingly engaging said chamber around said opening; releasable trigger means holding said member against outward movement through said opening whereby release of said trigger means permits air pressure in said chamber to force said member to pop outwardly through said opening and thereby suddenly release said pressure to produce sound simulating a gun.

2. A toy gun as defined in claim 1 including a tubular open-ended barrel, said outlet opening communicating with one end of said barrel whereby air issuing from said outlet opening, upon release of said member, issues from the other end of said barrel as a jet.

3. A toy gun as defined in claim 1 including dashpot means in said chamber and connected to said member for arresting excessive outward movement thereof when said trigger means is released.

4. A toy gun as defined in claim 3 wherein said dashpot means comprises a cylinder in said chamber; a piston in said cylinder connected to said member for movement therewith and serving to at least partially compress air in said cylinder in response to outward movement of said member and thereby urge said member to return inwardly of said outlet opening after release of pressure from said chamber.

5. A toy gun as defined in claim 4 wherein said piston is connected to said member by a rod extending therebetween, said rod extending through said member and said outlet opening and having an outer end portion engaging said releasable trigger means.

6. A toy gun as defined in claim 1 including a manually operable lever means for forcibly moving said member inwardly through said outlet opening to the interior of said chamber.

#### References Cited

##### UNITED STATES PATENTS

	843,573	2/1907	Blomen et al. ....	124—13
40	1,818,810	2/1931	Miller .....	124—13
	2,628,450	2/1953	Shelton .....	124—1 X
	2,996,823	8/1961	Weimer .....	46—175 X
	3,003,281	10/1961	Butler et al. ....	46—178

45 F. BARRY SHAY, *Primary Examiner*.

ANTON O. OECHSLE, *Examiner*.

W. R. BROWNE, *Assistant Examiner*.