



INTERNATIONAL APPLICATION PUBLISHED UNDER THE PATENT COOPERATION TREATY (PCT)

<p>(51) International Patent Classification <sup>6</sup> : <b>F16B 43/00, 39/32</b></p>	<p><b>A1</b></p>	<p>(11) International Publication Number: <b>WO 99/63237</b> (43) International Publication Date: 9 December 1999 (09.12.99)</p>
<p>(21) International Application Number: PCT/CA99/00473 (22) International Filing Date: 27 May 1999 (27.05.99) (30) Priority Data: 09/089,453 3 June 1998 (03.06.98) US (71) Applicant: PRATT &amp; WHITNEY CANADA INC. [CA/CA]; Jeffrey W. Astle, Legal Services (01BE5), 1000 Marie Victorin, Longueuil, Quebec J4G 1A1 (CA). (72) Inventor: LATULIPE, Eric; 1803 Kirouac #403, Longueuil, Quebec J4G 1T1 (CA). (74) Agent: ASTLE, Jeffrey, W.; Pratt &amp; Whitney Canada Inc., Legal Dept. (01BE5), 1000 Marie Victorin, Longueuil, Quebec J4G 1A1 (CA).</p>		<p>(81) Designated States: CA, JP, RU, European patent (AT, BE, CH, CY, DE, DK, ES, FI, FR, GB, GR, IE, IT, LU, MC, NL, PT, SE).  <b>Published</b> <i>With international search report.</i></p>

(54) Title: FLAT KEY WASHER

(57) Abstract

A key washer for interlocking a pair of concentric parts is described. The key washer is comprised of a flat, metal ring having an outer circumferential edge and an inner circumferential edge. Two or more formations are formed in the inner circumferential edge and adapted to be received on a mating formation of an inner one or the concentric parts. The outer circumferential edge has a plurality of straight flat sections for mating engagement with a corresponding configured surface of an outer one of the concentric parts. The metal ring prevents rotation between the concentric parts. The washer is utilized in a preferred application for interlocking an aircraft turbine engine high pressure rotor assembly and a tie shaft nut.

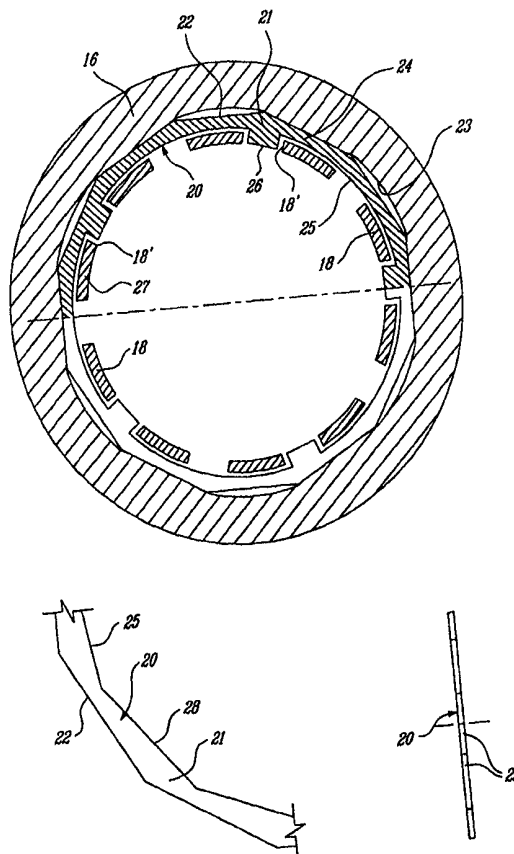

**FOR THE PURPOSES OF INFORMATION ONLY**

Codes used to identify States party to the PCT on the front pages of pamphlets publishing international applications under the PCT.

AL	Albania	ES	Spain	LS	Lesotho	SI	Slovenia
AM	Armenia	FI	Finland	LT	Lithuania	SK	Slovakia
AT	Austria	FR	France	LU	Luxembourg	SN	Senegal
AU	Australia	GA	Gabon	LV	Latvia	SZ	Swaziland
AZ	Azerbaijan	GB	United Kingdom	MC	Monaco	TD	Chad
BA	Bosnia and Herzegovina	GE	Georgia	MD	Republic of Moldova	TG	Togo
BB	Barbados	GH	Ghana	MG	Madagascar	TJ	Tajikistan
BE	Belgium	GN	Guinea	MK	The former Yugoslav Republic of Macedonia	TM	Turkmenistan
BF	Burkina Faso	GR	Greece	ML	Mali	TR	Turkey
BG	Bulgaria	HU	Hungary	MN	Mongolia	TT	Trinidad and Tobago
BJ	Benin	IE	Ireland	MR	Mauritania	UA	Ukraine
BR	Brazil	IL	Israel	MW	Malawi	UG	Uganda
BY	Belarus	IS	Iceland	MX	Mexico	US	United States of America
CA	Canada	IT	Italy	NE	Niger	UZ	Uzbekistan
CF	Central African Republic	JP	Japan	NL	Netherlands	VN	Viet Nam
CG	Congo	KE	Kenya	NO	Norway	YU	Yugoslavia
CH	Switzerland	KG	Kyrgyzstan	NZ	New Zealand	ZW	Zimbabwe
CI	Côte d'Ivoire	KP	Democratic People's Republic of Korea	PL	Poland		
CM	Cameroon	KR	Republic of Korea	PT	Portugal		
CN	China	KZ	Kazakstan	RO	Romania		
CU	Cuba	LC	Saint Lucia	RU	Russian Federation		
CZ	Czech Republic	LI	Liechtenstein	SD	Sudan		
DE	Germany	LK	Sri Lanka	SE	Sweden		
DK	Denmark	LR	Liberia	SG	Singapore		
EE	Estonia						

**FLAT KEY WASHER****BACKGROUND OF THE INVENTION**5    **1.    Technical Field**

          The present invention relates to a key washer for interlocking a pair of concentric parts and particularly, but not exclusively, for interlocking a coupling disk of an aircraft turbine engine high pressure rotor assembly and a tie shaft nut.

10**2.    BACKGROUND ART**

          Key washers are known for interlocking various types of concentric parts with a maximum of 3° adjustment between two mating parts. In particular, we are concerned with key washers for interlocking the high pressure disk assembly to a nut maintaining axial load with impeller through a tie shaft. In the prior art the standard key washer is provided with extension legs projecting from the outer and inner edges thereof. The outer extension legs are located in channels or grooves formed in the rotating disk. Because of their configuration these grooves increase stress concentration factor subjecting mating part (disk) to fatigue failure. It can be appreciated that the high pressure rotor assembly and the tie shaft are rotating at very high speeds and interconnected together through this key washer.

15  
20  
25**SUMMARY OF THE INVENTION**

          It is a feature of the present invention to provide a key washer for interlocking a pair of concentric parts and wherein the external legs of the key washer are replaced by straight flat sections for mating engagement with corresponding configured flat surface sections of an outer one of the concentric parts.

30  
35

Another feature of the present invention is to provide a key washer which substantially overcomes the above disadvantages of the prior art and which thereby reduces stress concentration on the rotor disk, particularly at high rotational speeds.

Another feature of the present invention is to reduce the machining cost of the outer mating part and reduce part deviation.

It is another feature of the present invention to provide a key washer having flat, straight formation means provided on both its outer and inner circumferential edge for mating engagement with like configured surface sections of an outer and inner concentric part to interlock the concentric parts together.

According to the above features, from a broad aspect, the present invention provides a key washer for interlocking a pair of concentric parts. The key washer comprises a metal ring having an outer circumferential edge and an inner circumferential edge. Two or more formation means are provided in the inner circumferential edge and adapted to mate with mating means of an inner one of the concentric parts. The outer circumferential edge has a plurality of straight flat sections for mating engagement with a corresponding configured inner surface section of an outer one of the concentric parts. The metal ring prevents rotation between the concentric parts.

### BRIEF DESCRIPTION OF DRAWINGS

A preferred embodiment of the present invention will now be described with reference to the accompanying drawings in which:

FIG. 1 is a simplified section view showing the construction of a standard key washer of the prior art

for connecting an inner concentric part to an outer concentric part;

FIG. 2A is a section view similar to Figure 1 but illustrating the improved key washer design of the present invention;

FIG. 2B is a fragmented plan view illustrating a further variant of the key washer of the present invention wherein the inner ring has six flat sections like the mating disk;

FIG. 2C is a side view of the key washer of Figure 2A;

FIG. 3 is a schematic illustration of an aircraft turbine engine showing the connection of the high pressure compressor to the high pressure disk assembly through a tie shaft forming the high pressure rotor; and

FIG. 4 is an enlarged view showing the interconnection of the tie shaft to the high pressure rotor through the flat key washer of the present invention which interconnects the coupling disk to the tie shaft nut.

#### **DESCRIPTION OF PREFERRED EMBODIMENTS**

Referring now to the drawings, and more particularly to Figure 1, there is shown at 10 a key washer constructed in accordance with the prior art. The key washer consists of a metal ring 11 having an outer circumferential edge 12 and an inner circumferential edge 13. Projecting legs, herein external projecting legs 14, are formed integral with the ring and extend from the outer circumferential edge 12. These legs are located in grooves or channels 15 formed in the coupling disk 16. The internal projecting legs 17 are disposed in slots 18' formed within the tie shaft nut 18.

The grooves 15 are of rectangular contour and it can be seen that when these concentric parts are rotating at very high speeds, the grooves, because of their size and

configuration, will subject the disk to stress concentration and this could cause failure of the disk.

With reference now to Figure 2, there is shown generally at 20 the improved key washer of the present invention. As hereinshown it is also constructed as a flat metal ring 21 but instead of external projecting legs formed on its outer circumferential edge, the edge is itself formed with a plurality of straight flat sections 22, herein twelve flat sections, disposed in a side-by-side relationship all around the key washer. The coupling disk 16 has an inner surface 23 which is provided with six mating flat surface sections 24 for receiving thereagainst six of the straight flat sections 22 of the key washer 20. Accordingly, the stress concentration factor is greatly reduced on the mating parts due to the smooth geometry. Another advantage of such improved key washer is that it results in a cost saving in the manufacture of the coupling disk.

Like the key washer of the prior art, the inner circumferential edge 25 is also provided with internal projecting legs 26 which locate within the slots 18 of the tie shaft nut 27.

Figure 2B shows a modification of the key washer 20 wherein the inner circumferential edge 25 may also be formed with straight flat sections 28 offset from the flat sections 22 formed on the outer peripheral edge of the ring. The tie shaft nut 27 would then have to be machined to provide flat mating surface sections to contact therewith.

Figure 2C is a side view of the ring to illustrate the flatness thereof as well as the disposition of the straight flat sections 22.

Figure 3 is a simplified section view showing a high pressure rotor assembly 30 of an aircraft turbine engine. The high pressure disk assembly 31 is connected to the

tie shaft 32 through the nut 18, as better seen from Figure 4, to couple the high pressure compressor assembly 33 to the disk assembly 31. As shown in Figure 4, the key washer 20 is secured to the tie shaft nut 18 through its projecting legs 26 extending with the slots 18' of the nut 18. The nut 18 is coupled to the tie shaft 32 through a threaded connection 34. The flat sections 22 are in mating engagement with corresponding flat surface sections 24 formed in the disk. A retention clip 36 maintains the key washer captive.

Those skilled in the art will appreciate that the conception, upon which this disclosure is based, may readily be utilized as a basis for the designing of other structures, for carrying out the several purposes of the present invention. It is important, therefore that the claims be regarded as including such equivalent constructions insofar as they do not depart from the spirit and scope of the present invention.

## CLAIMS,

1. A key washer for interlocking a pair of concentric parts comprising a metal ring having an outer  
5 circumferential edge and an inner circumferential edge, two or more formation means in said inner circumferential edge and adapted to mate with mating means of an inner one of said concentric parts, said outer circumferential edge having a plurality of straight flat sections for  
10 mating engagement with a corresponding configured inner surface section of an outer one of said concentric parts, said metal ring preventing relative rotation between said concentric parts.
- 15 2. A key washer as claimed in claim 1 wherein said metal ring is a flat metal ring, said outer and inner circumferential edges being narrow edges.
- 20 3. A key washer as claimed in claim 2 wherein said flat sections are disposed in side-by-side relationship about said entire outer circumferential edge.
- 25 4. A key washer as claimed in claim 3 wherein said formation means are spaced-apart tabs formed integral with said flat metal ring and projecting from said inner circumferential edge.
- 30 5. A key washer as claimed in claim 4 wherein said tabs are of rectangular configuration defining short end edges and a long straight outer end edge.
- 35 6. A key washer as claimed in claim 3 wherein said formation means are spaced straight flat sections disposed side-by-side along said inner circumferential edge.

7. A key washer as claimed in claim 1 wherein said  
outer concentric part is a coupling disk of an aircraft  
turbine engine high pressure rotor assembly and said  
inner concentric part is a tie shaft nut secured to a tie  
5 shaft connected to a high pressure compressor.

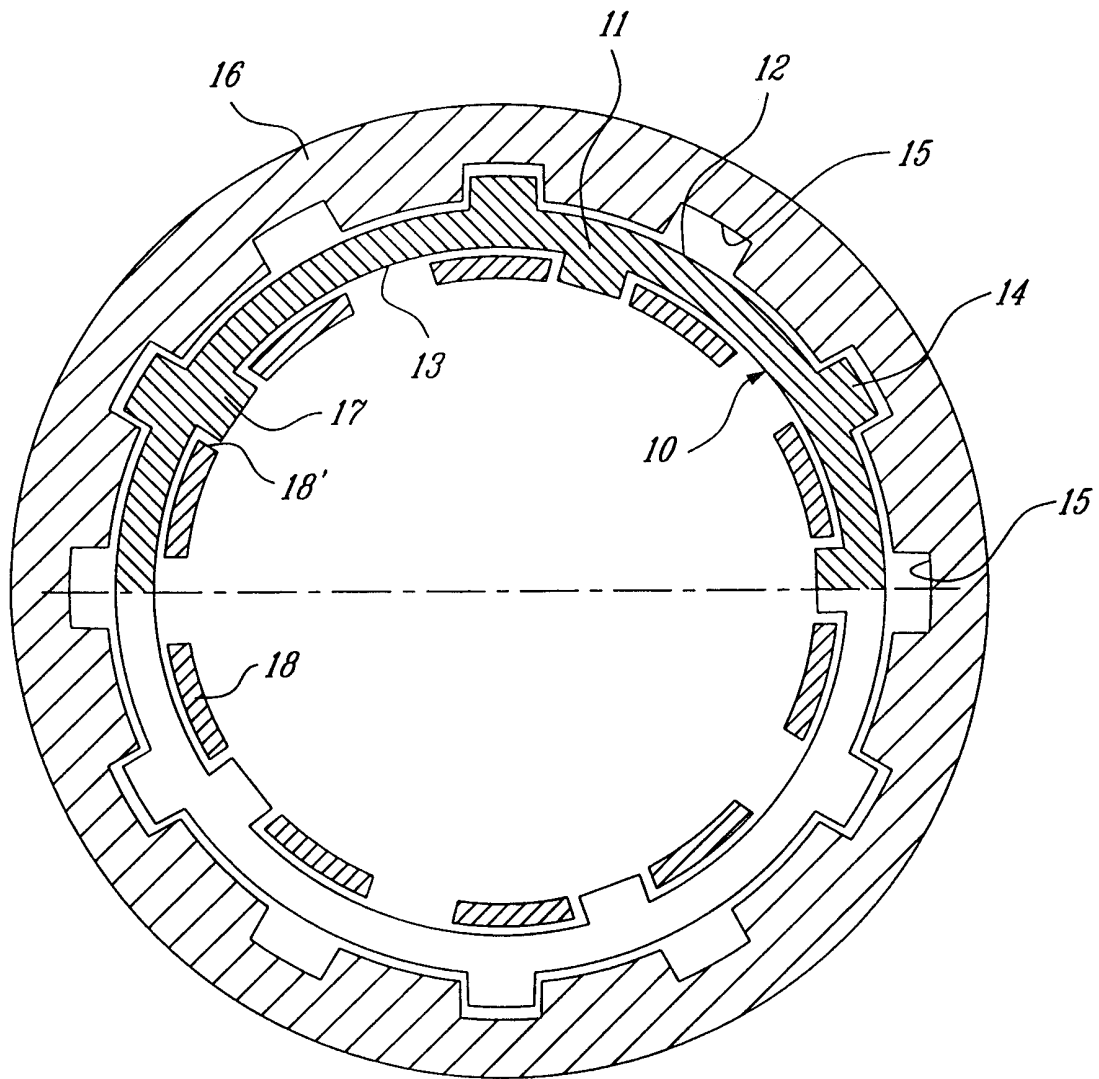

FIG. 1     PRIOR ART

2/4

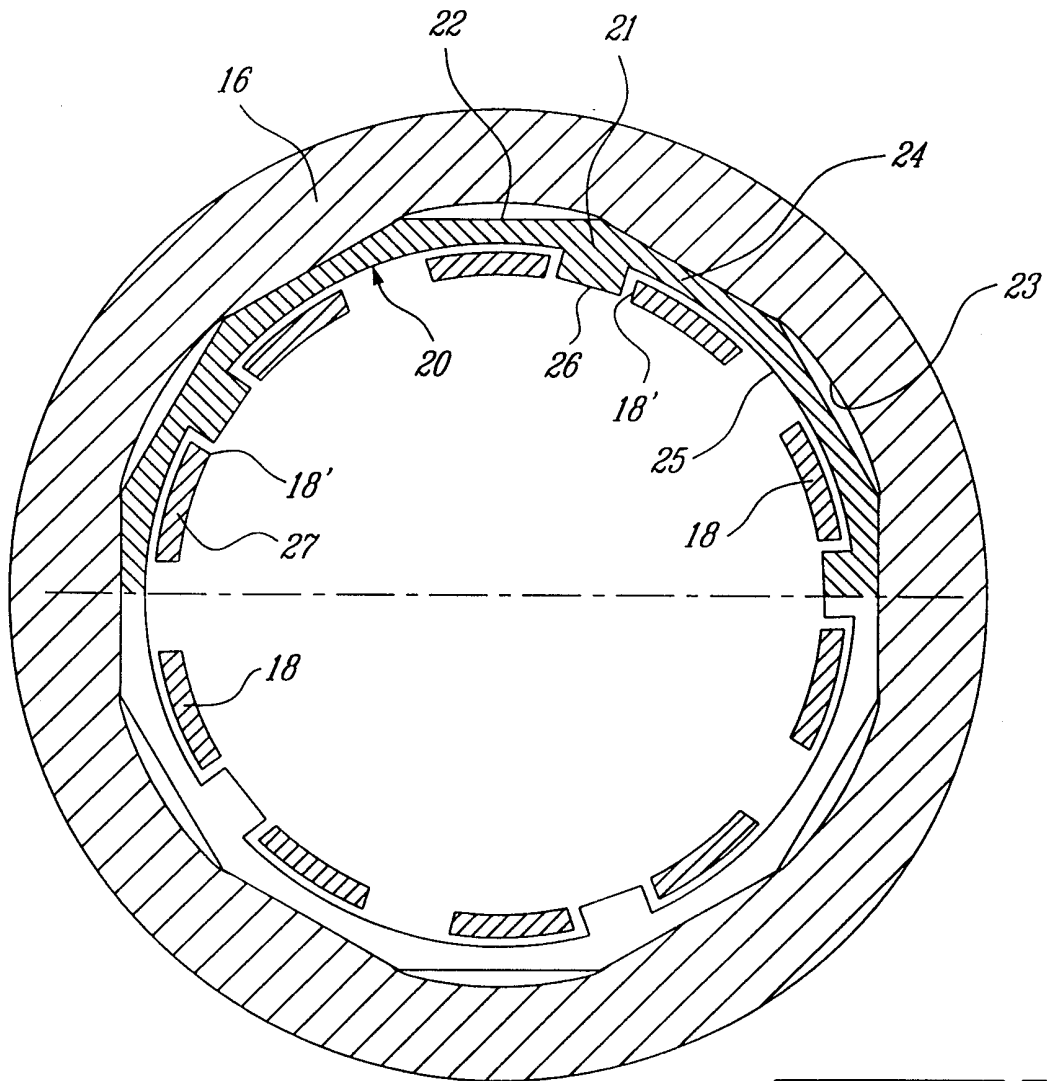

FIG. 2A

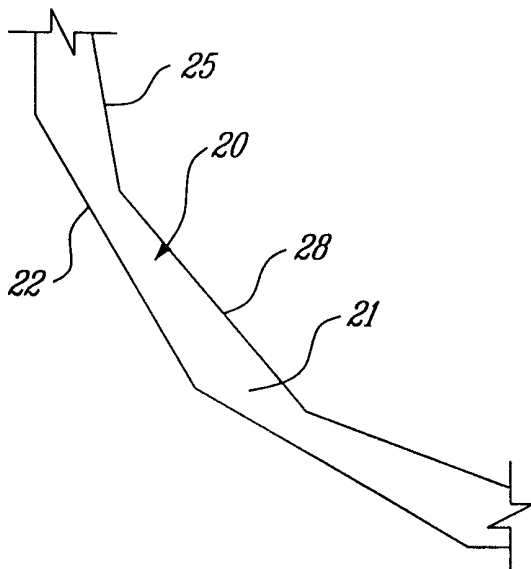

FIG. 2B

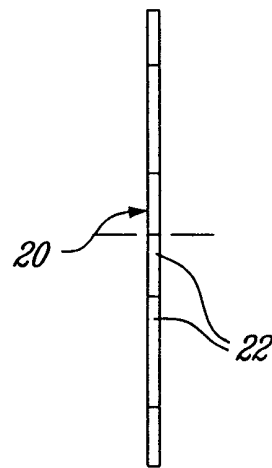
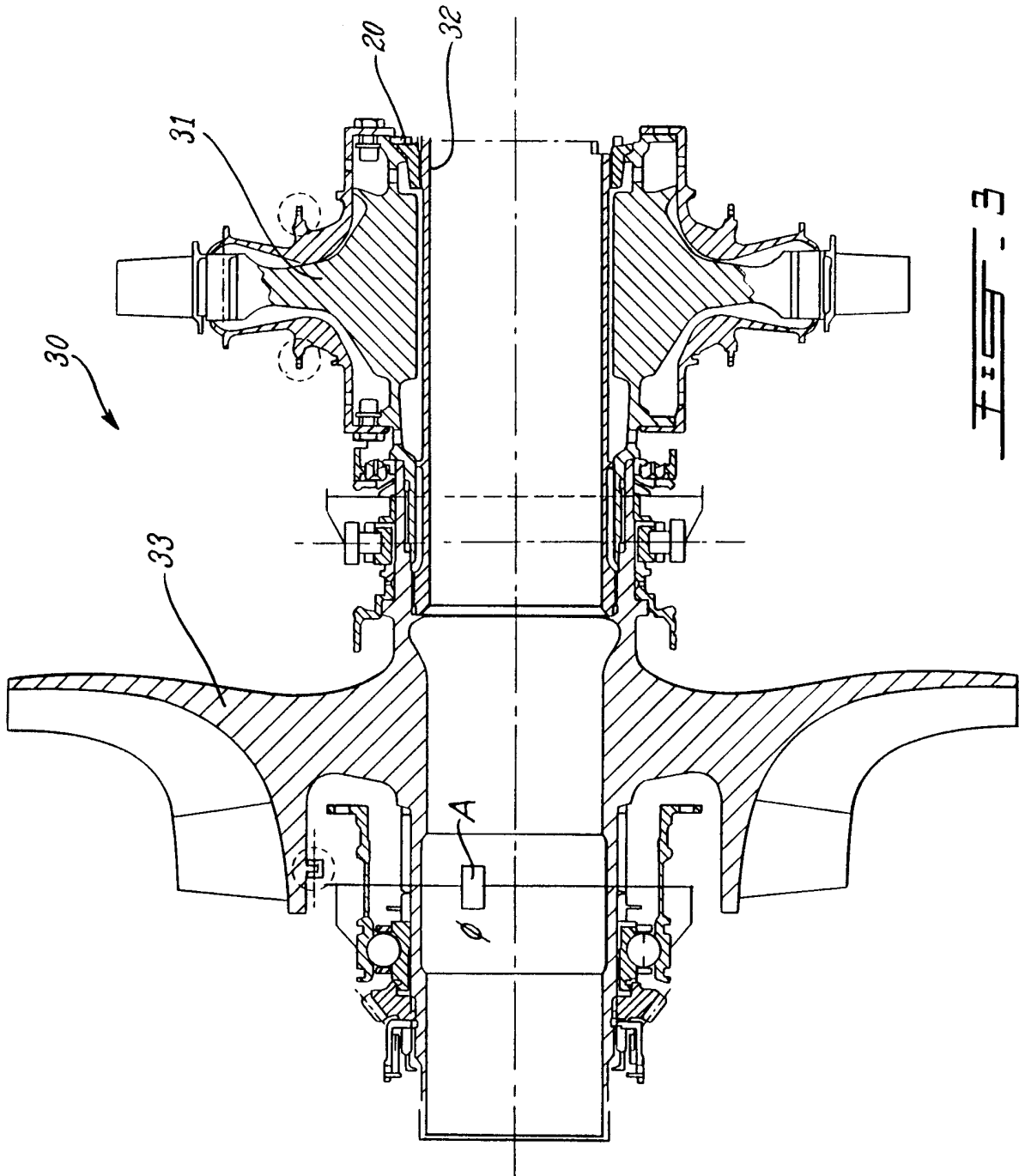

FIG. 2C

3 / 4



1:1

4/4

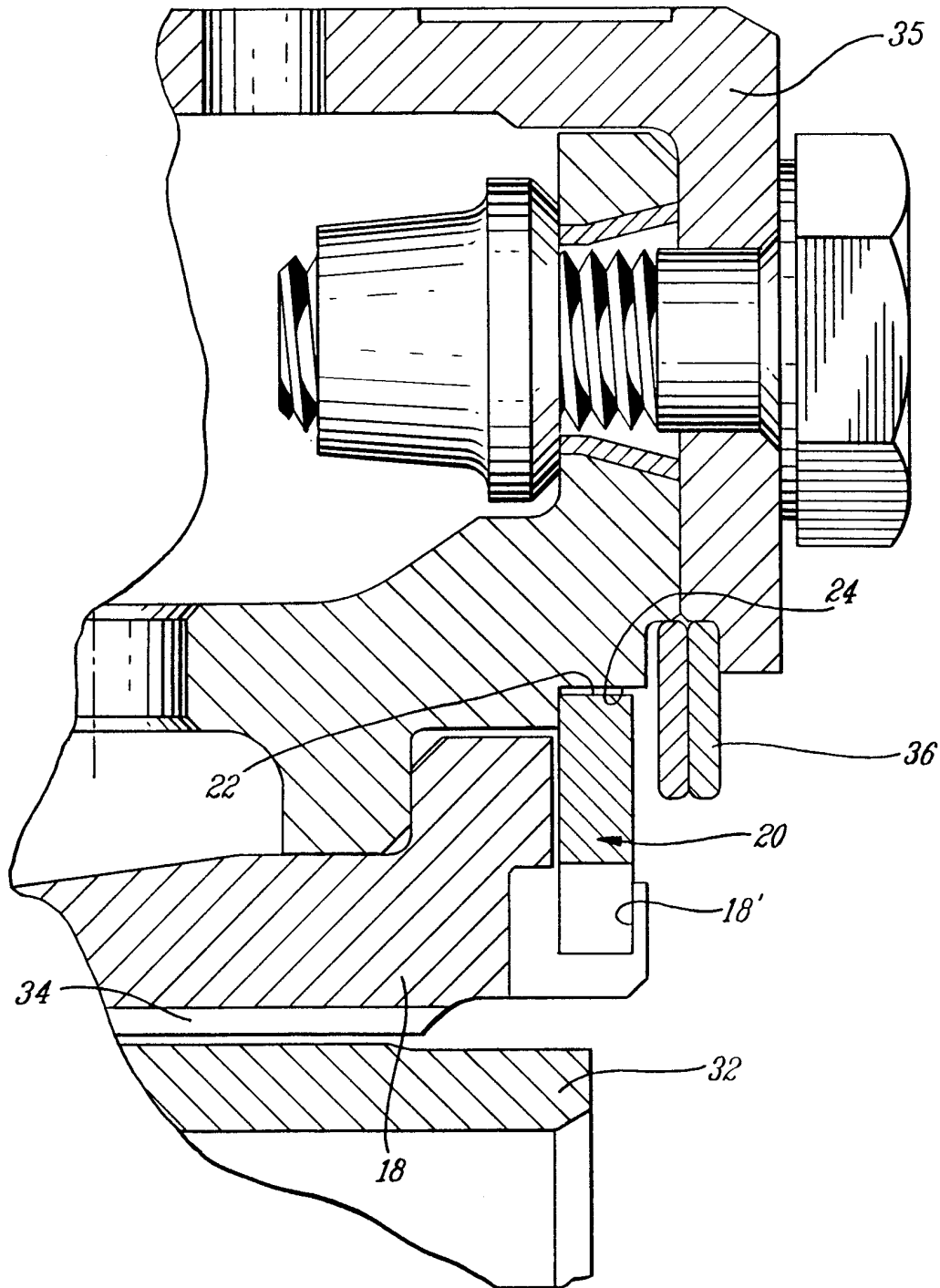

FIG. 4

# INTERNATIONAL SEARCH REPORT

Information on patent family members

In. tional Application No

PCT/CA 99/00473

Patent document cited in search report	Publication date	Patent family member(s)	Publication date
US 3032089 A	01-05-1962	NONE	
US 2675844 A	20-04-1954	NONE	
EP 0321316 A	21-06-1989	GB 2212585 A	26-07-1989
GB 2277570 A	02-11-1994	NONE	