

(19) World Intellectual Property Organization
International Bureau



(43) International Publication Date
19 July 2007 (19.07.2007)

PCT

(10) International Publication Number
WO 2007/081149 A1

- (51) International Patent Classification:
H04N 5/76 (2006.01)
- (21) International Application Number:
PCT/KR2007/000166
- (22) International Filing Date: 9 January 2007 (09.01.2007)
- (25) Filing Language: Korean
- (26) Publication Language: English
- (30) Priority Data:
60/757,279 9 January 2006 (09.01.2006) US
10-2006-0125051 8 December 2006 (08.12.2006) KR
10-2007-0002187 8 January 2007 (08.01.2007) KR

- (72) Inventors; and
- (75) Inventors/Applicants (for US only): BAE, Seong-Jun [KR/KR]; 210-704 Daewoo Dreamtown Apt., Yeongdeungpo-dong, Yeongdeungpo-gu, Seoul 150-030 (KR). CHO, Yong-Ju [KR/KR]; 1-1105 Kukdong Apt., Suyu6-dong, Gangbuk-gu, Seoul 142-781 (KR). KIM, Jae-Gon [KR/KR]; 203-402 Sammuri Apt. 11-1, Doosan2-dong, Seo-gu, Daejeon-city 302-777 (KR). HONG, Jin-Woo [KR/KR]; Rm. 907 Royal valley 385-15, Doryong-dong, Yusong-gu, Daejeon-city 305-340 (KR).

(74) Agent: Y.P. LEE, MOCK & PARTNERS; 1575-1, Seocho-dong, Seocho-gu, Seoul 137-875 (KR).

(81) Designated States (unless otherwise indicated, for every kind of national protection available): AE, AG, AL, AM, AT, AU, AZ, BA, BB, BG, BR, BW, BY, BZ, CA, CH, CN, CO, CR, CU, CZ, DE, DK, DM, DZ, EC, EE, EG, ES, FI, GB, GD, GE, GH, GM, GT, HN, HR, HU, ID, IL, IN, IS, JP, KE, KG, KM, KN, KP, KZ, LA, LC, LK, LR, LS, LT, LU, LV, LY, MA, MD, MG, MK, MN, MW, MX, MY, MZ, NA, NG, NI, NO, NZ, OM, PG, PH, PL, PT, RO, RS, RU,

[Continued on next page]

(71) Applicant (for all designated States except US): ELECTRONICS AND TELECOMMUNICATIONS RESEARCH INSTITUTE [KR/KR]; 161, Gajeong-dong, Yusong-gu, Daejeon-city 305-350 (KR).

(54) Title: SVC FILE DATA SHARING METHOD AND SVC FILE THEREOF

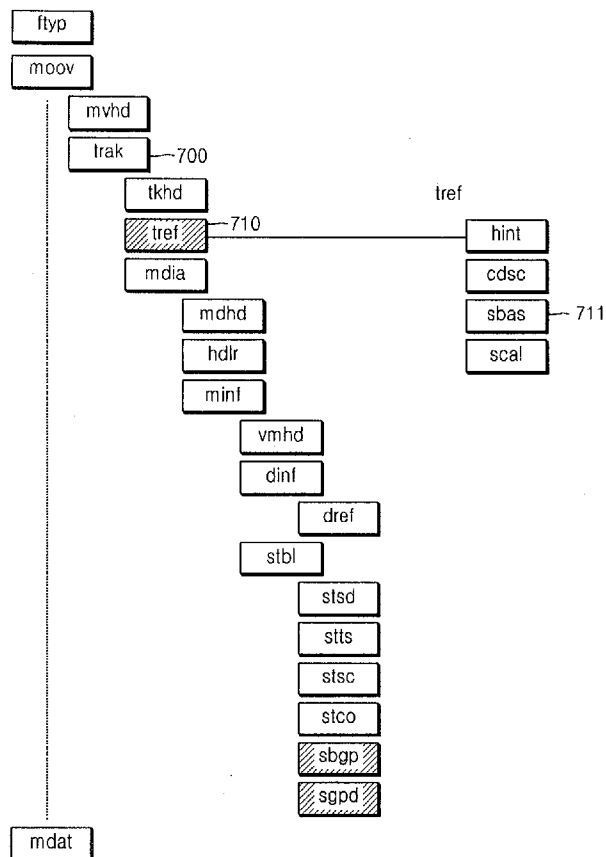

(57) Abstract: A method of sharing data of a scalable video coding (SVC) file and the SVC file are provided. The SVC file includes: a scalable base track including at least one scalable layer entry each storing metadata of the at least one scalable layer; and at least one sub track generated based on the scalable base track, which includes identification information of the scalable layer that is a basis of generation of a sub track among the scalable layers and identification information of the scalable base track instead of the scalable layer entry. Accordingly, when an SVC coded content is stored as a file, it is possible to reduce a storage capacity by avoiding duplication of common data and to provide convenience when the stored content is reprocessed by allowing a relation of tracks correlated to one another to be represented.

WO 2007/081149 A1



SC, SD, SE, SG, SK, SL, SM, SV, SY, TJ, TM, TN, TR,
TT, TZ, UA, UG, US, UZ, VC, VN, ZA, ZM, ZW.

RO, SE, SI, SK, TR), OAPI (BF, BJ, CF, CG, CI, CM, GA,
GN, GQ, GW, ML, MR, NE, SN, TD, TG).

(84) Designated States (*unless otherwise indicated, for every kind of regional protection available*): ARIPO (BW, GH, GM, KE, LS, MW, MZ, NA, SD, SL, SZ, TZ, UG, ZM, ZW), Eurasian (AM, AZ, BY, KG, KZ, MD, RU, TJ, TM), European (AT, BE, BG, CH, CY, CZ, DE, DK, EE, ES, FI, FR, GB, GR, HU, IE, IS, IT, LT, LU, LV, MC, NL, PL, PT,

Published:

— *with international search report*

For two-letter codes and other abbreviations, refer to the "Guidance Notes on Codes and Abbreviations" appearing at the beginning of each regular issue of the PCT Gazette.

SVC FILE DATA SHARING METHOD AND SVC FILE THEREOF**TECHNICAL FIELD**

5 The present invention relates to a method of sharing data of a scalable video coding (SVC) file and the SVC file, and more particularly, to a method of sharing data of an SVC file by sharing metadata of tracks and using a base track reference and the SVC file thereof.

BACKGROUND ART

10

FIG. 1 illustrates a concept of scalable video coding (SVC).

Referring to FIG. 1, in SVC, a plurality of video layers are coded into a single bit string.

15 An SVC layer is constructed with a base layer and one or more enhancement layers stacked on the base layer.

Each enhancement layer can represent the maximum bit rate, frame rate, and resolution based on information about a lower layer.

In the SVC, as the number of sequentially stacked enhancement layers increases, various bit rates, frame rates, and resolutions can be supported.

20

The SVC is a coding technique capable of solving problems pertaining to a variety of bandwidths occurring in heterogeneous network environments, a variety of performances and resolutions of receiving terminals, a variety of preferences of content consumers, and the like.

FIG. 2 illustrates a format of a multimedia file.

25

In general, when a video content is desired to be stored as a file, metadata about a coding method, contents, and any access information for the content are separately stored so as to secure free access to any location of the content and to easily reprocess the content, in addition to media data of the content.

30 In addition, a unit of track is defined as a unit of a medium which is continuously reproducible.

Referring to FIG. 2, a multimedia file is stored as a structure having an audio track and a video track.

When the video content is coded into an SVC format, the multimedia file may have two or more video tracks, due to a feature of SVC.

FIG. 3 illustrates scalable layers of SVC coded content.

The SVC has a feature of coding a plurality of video layers into a single bit string.

Referring to FIG. 3, a scalable base bit-stream is a single bit-stream (p1 to pm) having the highest image quality. The scalable base bit-stream includes the total
5 coded data 310.

A sub bit-stream (to-be-transmitted coded data a which ranges from 0 to a, or to-be-transmitted coded data b which ranges from 0 to b) can be freely generated according to a bandwidth supported by a network or a specification of a user terminal.

A sub bit-stream a 320 includes the to-be-transmitted coded data a. A sub
10 bit-stream b 330 includes the to-be-transmitted coded data b.

A scalable base bit-stream, a sub bit-stream a and a sub bit-stream b are constructed with one or more scalable layers p1 to pi.

The scalable base bit-stream includes all the scalable layers p1 to pi.

The other sub bit-streams include scalable layers having a specific range (sub
15 bit-stream a includes scalable layers p1 to pi, or sub bit-stream b includes scalable layers p1 to p3).

FIG. 4 illustrates a format of an SVC file in which SVC coded content is stored.

Referring to FIG. 4, the scalable base bit-stream and the sub bit-stream can be respectively constructed with separate tracks, which are generally referred to as a
20 scalable base track and a sub track.

In this case, two or more video tracks may be included in a file. When two or more video tracks are included in a file, metadata for representing scalable layers may be separately included in the file according to the tracks.

Conventionally, when SVC coded content is stored in a file, ① data is repeated
25 and duplicated in the common parts of the metadata of tracks, and ② a relation of the tracks correlated to one another cannot be represented.

DETAILED DESCRIPTION OF THE INVENTION

TECHNICAL PROBLEM

30 The present invention provides a method of sharing data of a scalable video coding (SVC) file and the SVC file capable of reducing a storage capacity by avoiding duplication of common data and providing convenience when stored content is reprocessed by allowing a relation of tracks correlated to one another to be represented, when an SVC coded content is stored as a file.

TECHNICAL SOLUTION

According to an aspect of the present invention, there is provided a method of sharing data of a scalable video coding (SVC) file having media data which includes at least one scalable layer in each frame, the method comprising: storing at least one scalable layer entry, in which metadata for the at least one scalable layer included in the media data is stored, in a scalable base track; storing identification information of the at least one scalable layer and identification information of scalable base tracks in a sub track generated based on the part of the at least one scalable layer included in the media data which is a basis of the scalable base track; and sharing the scalable layer entry stored in the scalable base track on the basis of the identification information of the scalable layers and the identification information of the scalable base track.

According to another aspect of the present invention, there is provided a method of sharing data of an SVC file having a plurality of media data including scalable base tracks having at least one scalable layer, the method comprising storing identification information of the scalable base track, which is a basis of generation of a sub track among the scalable base tracks, in at least one sub track generated based on one of the scalable base tracks.

According to another aspect of the present invention, there is provided an SVC file having media data including at least one scalable layer in each frame, the SVC file comprising: a scalable base track including at least one scalable layer entry each storing metadata of the at least one scalable layer; and at least one sub-track generated based on the scalable base track, which includes identification information of the scalable layer that is a basis of generation of a sub track among the scalable layers and identification information of the scalable base track, instead of the scalable layer entry.

According to another aspect of the present invention, there is provided an SVC file having a plurality of media data including scalable base tracks having at least one scalable layer, the SVC file comprising at least one sub track which is generated based on one of the plurality of scalable base tracks in which identification information of the scalable base track that is a basis of generation of a sub track among the plurality of scalable base tracks is stored.

ADVANTAGEOUS EFFECTS

Accordingly, when scalable video coding (SVC) coded content is stored as a file,

① it is possible to avoid duplication of common data of scalable layers by sharing metadata of tracks. ② It is also possible to represent a relation of tracks correlated to one another by including a base track reference.

5

DESCRIPTION OF THE DRAWINGS

The above and other features and advantages of the present invention will become more apparent by describing in detail exemplary embodiments thereof with reference to the attached drawings in which:

FIG. 1 illustrates a concept of scalable video coding (SVC);

10

FIG. 2 illustrates a format of a multimedia file;

FIG. 3 illustrates scalable layers of SVC coded content;

FIG. 4 illustrates a format of an SVC file in which SVC coded content is stored;

FIG. 5 illustrates scalable layer entries stored in each track of metadata of an SVC file;

15

FIG. 6a illustrates an SVC file that shares a scalable layer entry among tracks according to an exemplary embodiment of the present invention;

FIG. 6b illustrates a flowchart of a method of sharing a scalable layer entry among tracks of metadata of an SVC file according to an exemplary embodiment of the present invention;

20

FIG. 7a illustrates an SVC file including identification information of a scalable base track according to an exemplary embodiment of the present invention; and

FIG. 7b illustrates a method of managing sub-tracks by binding sub-tracks which have the same scalable base track according to an exemplary embodiment of the present invention.

25

BEST MODE

Hereinafter, exemplary embodiments of the present invention will be described in detail with reference to the attached drawings.

1. Sharing of metadata according to tracks

30

FIG. 5 illustrates scalable layer entries stored in each track of metadata of a scalable video coding (SVC) file.

Referring to FIG. 5, a scalable base track and a sub track generated based on the scalable base track may have the same scalable layer entry ScalableLayerEntry of a layer 1.

When SVC coded content is stored as a file, metadata including additional information for each scalable layer is referred to as a scalable layer entry ScalableLayerEntry.

5 In the SVC file, a sample group description box (sgpd) of a track includes the scalable layer entry ScalableLayerEntry.

When different sub tracks are generated based on the scalable base track, the sub tracks include the common scalable layers.

The common scalable layers include the same metadata ScalableLayerEntry. Data is duplicated with respect to the common part of the metadata.

10 FIG. 6a illustrates an SVC file that shares a scalable layer entry ScalableLayerEntry according to an exemplary embodiment of the present invention.

According to the current embodiment, identification information ref_track ID of the scalable base track for designating the scalable base track and identification information ref_layer ID of the scalable layer for designating the scalable layer are used instead of
15 recording the same metadata ScalableLayerEntry for the common scalable layer on each track.

The scalable base track includes a scalable layer entry having metadata for the scalable layer.

20 The sub track generated based on the scalable base track includes identification information of the scalable layer and identification information of the scalable base track, which is the basis of the generation of the sub track among scalable layers, instead of the scalable layer entry.

In FIG. 6a, the sub track uses the identification information ref_track ID = 1 of the
25 scalable base track for designating the scalable base track and the identification information ref_layer ID = 1 of the scalable layer for designating the scalable layer without repeatedly storing the scalable layer entry ScalableLayerEntry.

The identification information of the scalable layer that is the basis of generation of the sub track and the identification information of the scalable base track can be
30 represented in the sgpd track.

Syntax for sharing the value of the scalable layer entry ScalableLayerEntry of the scalable base track using identification information ref_track ID of the scalable base track and the identification information of the scalable layer is described here below.

```

class ScalableLayerEntry() extends VisualSampleGroupEntry ('scif') {
  unsigned int(8) groupID;
  unsigned int(8) layerID;
  unsigned int(8) group_flags;
  unsigned int(8) reserved = 0;

  if((group_flag & 04) != 04){
    if ((group_flags & 01) == 01) // primary definition of layer
    {
      SVCDependencyDescriptionEntryBox(); // Mandatory Box

      //Optional Boxes or fields may follow when defined later
      RectRegionBox(); // optional
      BufferingBox(); // optional
      LayerDependencyBox(); // optional
      ScalabilityInformationSEIBox(); //optional
    }
    if ((group_flags & 02) == 02)
    {
      unsigned int(8) entry_count;
      for (j=0; j < entry_count; j++)
        signed int(16) delta_layer_id;
    }
  }
  else
  {
    unsigned int(32) ref_trackID;
    unsigned int(8) ref_layerID;

    // followings are only used to override existing descriptors or add new one
    if ((group_flags & 01) == 01) // primary definition of layer
    {
      //Optional Boxes or fields may follow when defined later
      RectRegionBox(); // optional
      BufferingBox(); // optional
      LayerDependencyBox(); // optional
      ScalabilityInformationSEIBox(); //optional
    }
    if ((group_flags & 02) == 02)
    {
      unsigned int(8) entry_count;
      for (j=0; j < entry_count; j++)
        signed int(16) delta_layer_id;
    }
  }
}

```

According to an embodiment of the present invention, it is unnecessary to repeatedly store the same contents of the original metadata by including the identification information ref_track ID of the scalable base track and the identification information ref_layer ID of the scalable layer and allowing all the metadata to refer to the original metadata.

FIG. 6b illustrates a flowchart of a method of sharing a scalable layer entry ScalableLayerEntry among tracks of metadata of an SVC file according to an exemplary embodiment of the present invention.

First, a scalable layer entry ScalableLayerEntry, which stores the metadata for the scalable layer included in the media data of the SVC file, is stored in the scalable base track (operation S601).

The identification information of the scalable layer and the identification information of the scalable base track which is the basis of generation of the sub track are stored in the sub track generated based on the scalable base track (operation S602).

The scalable layer entry is shared based on the identification information of the

scalable layer and the identification information of the scalable base track, which is the basis of generation of the sub track and stored in the sub track, with the scalable base track (operation S603).

5 The identification information of the scalable layer and the identification information of the scalable base track, which is the basis of generation of the sub track, can be represented in the sgpd track of the scalable sub track.

In the present invention, it is possible to avoid repeating the common data according to scalable layers by sharing metadata for tracks. Hereinafter, the base track reference for representing a relation among the correlated tracks according to an
10 embodiment of the present invention will be described.

2. Base track reference

FIG. 7a illustrates an SVC file including identification information of a scalable base track according to an exemplary embodiment of the present invention.

According to the embodiment, it is possible to indicate the corresponding track,
15 from which each sub track is derived, in the sub track.

It is possible to provide a convenience when the stored content is reprocessed by allowing the relation of the tracks correlated to one another to be represented.

Referring to FIG. 7a, metadata trak 700 for representing a track includes lower level metadata that is a track reference tref 710.

20 Syntax of the track reference tref 710 is described here below.

```
aligned(8) class TrackReferenceBox extends Box("tref") {
}
aligned(8) class TrackReferenceTypeBox (unsigned int(32) reference_type) extends
Box(reference_type) {
    unsigned int(32) track_IDs[];
}
```

The track reference tref 710 may include a plurality of track-IDs depending on types.

It is possible to indicate the corresponding track, from which each sub track is
25 derived, in the sub track by storing a type of the track ID of the scalable base track, which is referred to as sbas 711, in the track reference tref 710.

Similar to the type sbas 711 according to the current embodiment, types hint, cdsc, and scal also indicate functions of the tracks and refer to tracks in which the tracks are used.

30 According to the current embodiment, when the tracks having the same presentation are constructed with a scalable base track and a plurality of sub tracks derived from the scalable base track, a reference sbas 711, through which the scalable

base track can be found, and a relation of sub tracks can be represented in the sub tracks.

FIG. 7b illustrates a method of managing sub tracks by binding sub tracks which have the same scalable base track according to an exemplary embodiment of the present invention.

When content is stored as a file, two or more presentations can be stored in a file.

In this case, when the content is SVC coded content, the scalable base track and one or more sub tracks derived from the scalable base track separately from the scalable base track may be included in each presentation.

In this case, the sub track may have to determine the scalable base track from which the sub track is derived.

It is possible to manage the sub tracks by binding sub tracks which have the same scalable base track by indicating the corresponding scalable base track, from which each sub track is derived, in the sub track and storing the track ID of the scalable base track in the type sbas 711.

Referring to FIG. 7b, sub tracks A and B are generated based on a scalable base track X.

The scalable base track, from which the sub tracks A and B are derived, is indicated by storing the scalable base track X in the sbas track of the track reference tref of the sub tracks A and B (operation S701).

Sub tracks C and D are generated based on a scalable base track Y.

The scalable base track, from which the sub tracks C and D are derived, is indicated by storing the scalable base track Y in the sbas track of the track reference tref of the sub tracks C and D (operation S702).

According to the current embodiment, it is possible to manage the sub tracks by binding sub tracks generated based on the same scalable base track on the basis of the identification information of the scalable base track.

For example, there may be a case where it is desired that all the tracks generated based on the scalable base track Y be deleted.

In this case, according to the current embodiment, it is possible to easily manage all the sub tracks generated from the scalable base track Y by deleting all the tracks having the track ID of the scalable base track Y in the sbas track with reference to the sbas track of the track reference tref.

In the present invention, a waste of storage space for the duplicated metadata

ScalableLayerEntry is prevented by sharing the metadata ScalableLayerEntry for representing the scalable layer of the sub track by using only the identification information ref_track ID of the scalable base track and the identification information ref_layer ID of the scalable layer

5 In addition, convenience is provided when the stored content is reprocessed by allowing the relation of the correlated tracks to be represented by including the base track reference, which is sbas, in the sub track.

The invention can also be embodied as computer readable codes on a computer readable recording medium. The computer readable recording medium is any data
10 storage device that can store data which can be thereafter read by a computer system. Examples of the computer readable recording medium include read-only memory (ROM), random-access memory (RAM), CD-ROMs, magnetic tapes, floppy disks, optical data storage devices, and carrier waves (such as data transmission through the Internet). The computer readable recording medium can also be distributed over network coupled
15 computer systems so that the computer readable code is stored and executed in a distributed fashion.

While the present invention has been particularly shown and described with reference to exemplary embodiments thereof, it will be understood by those skilled in the art that various changes in form and details may be made therein without departing from
20 the spirit and scope of the invention as defined by the appended claims. The exemplary embodiments should be considered in descriptive sense only and not for purposes of limitation. Therefore, the scope of the invention is defined not by the detailed description of the invention but by the appended claims, and all differences within the scope will be construed as being included in the present invention.

25

INDUSTRIAL APPLICABILITY

As described above, when scalable video coding (SVC) coded content is stored as a file, it is possible to reduce storage capacity by avoiding duplication of common data and to provide convenience when the stored content is reprocessed by allowing a
30 relation of tracks correlated to one another to be represented.

CLAIMS

1. A method of sharing data of an SVC (scalable video coding) file having media data which includes at least one scalable layer in each frame, the method comprising:
- 5 storing at least one scalable layer entry, in which metadata for the at least one scalable layer included in the media data is stored, in a scalable base track;
storing identification information of the at least one scalable layer and identification information of scalable base tracks in a sub track generated based on the part of the scalable layers included in the media data which is a basis of the scalable
- 10 base track; and
sharing the scalable layer entry stored in the scalable base track on the basis of the identification information of the scalable layers and the identification information of the scalable base track.
- 15 2. The method of claim 1, wherein the identification information of the part of the scalable layers and the identification information of the scalable base track is represented in an sgp track of the scalable sub track.
3. A method of sharing data of an SVC file having a plurality of media data
- 20 which includes scalable base tracks having at least one scalable layer, the method comprising storing identification information of the scalable base track that is a basis of generation of a sub track among the scalable base tracks in at least one sub track generated based on one of the scalable base tracks.
- 25 4. The method of claim 3, further comprising managing the at least one sub track by binding sub tracks which are generated based on the same scalable base track on the basis of the identification information of the scalable base track.
5. The method of claim 3 or 4, wherein the identification information of the
- 30 scalable base track is represented in an sbas track of a track reference type box including track reference information of the at least one sub track.
6. An SVC file having media data which includes at least one scalable layer in each frame, the SVC file comprising:
a scalable base track including at least one scalable layer entry each storing

metadata of the at least one scalable layer; and

at least one sub track generated based on the scalable base track, which includes identification information of the scalable layer that is a basis of generation of a sub track among the scalable layers and identification information of the scalable base track instead of the scalable layer entry.

7. The SVC file of claim 6, wherein the identification information of the scalable layer which is the basis of generation of the sub track among the scalable layers and the identification information of the scalable base track is represented in an sgpd (sample group description box) track of the sub track.

8. An SVC file having a plurality of media data which includes scalable base tracks having at least one scalable layer, the SVC file comprising at least one sub track which is generated based on one of the plurality of scalable base tracks in which identification information of the scalable base track that is a basis of generation of a sub track among the plurality of scalable base tracks is stored.

9. The SVC file of claim 8, wherein the identification information of the scalable base track is represented in an sbas track of a track reference type box including track reference information of the sub track.

10. A computer-readable recording medium having embodied thereon a computer program for executing the method of any one of claims 1 to 5.

FIG. 1

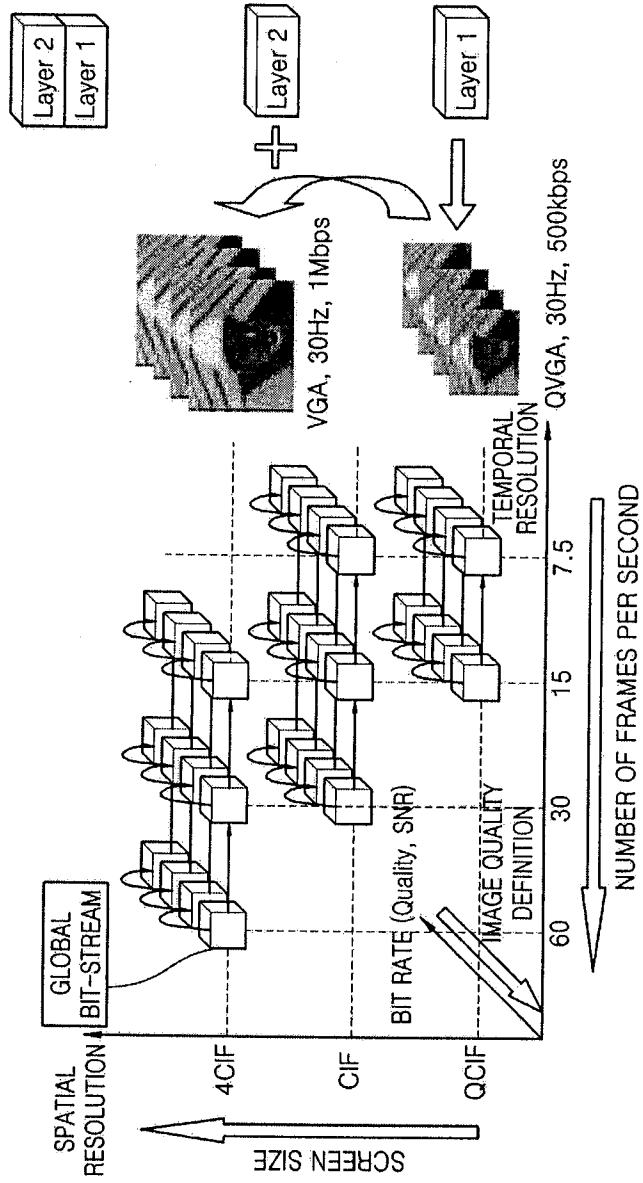

FIG. 2

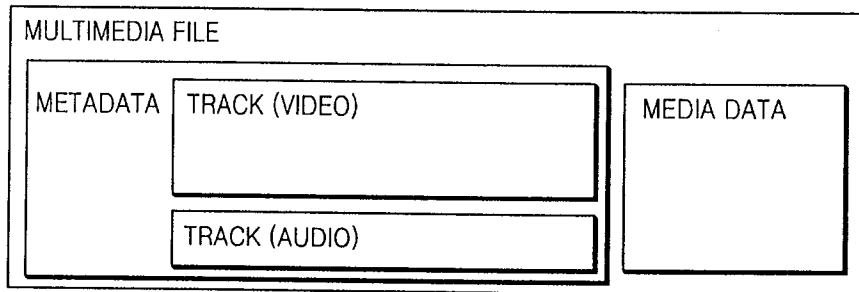

FIG. 3

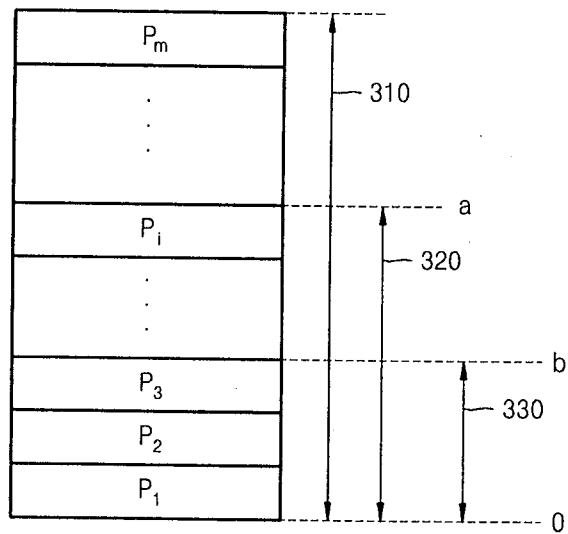

FIG. 4

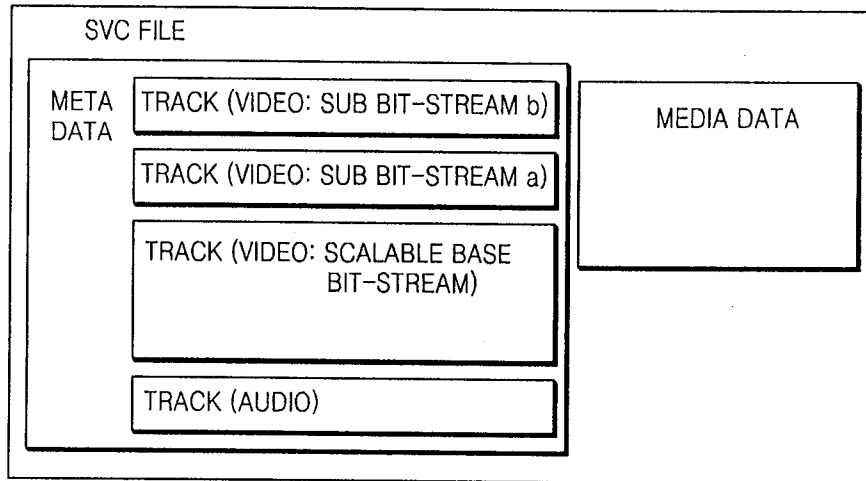

FIG. 5

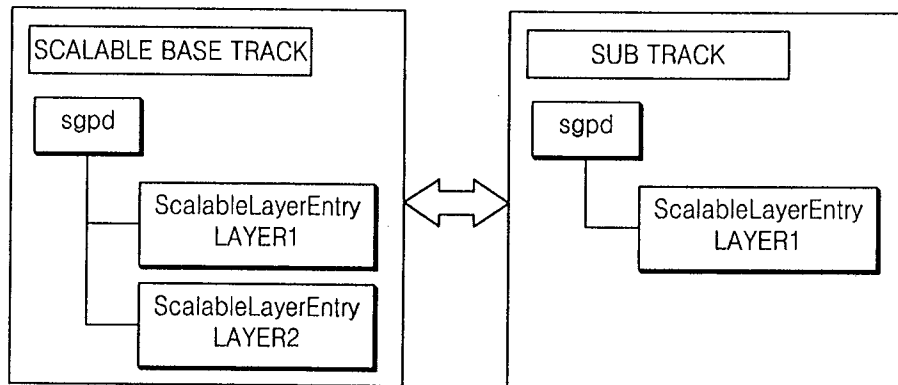

FIG. 6A

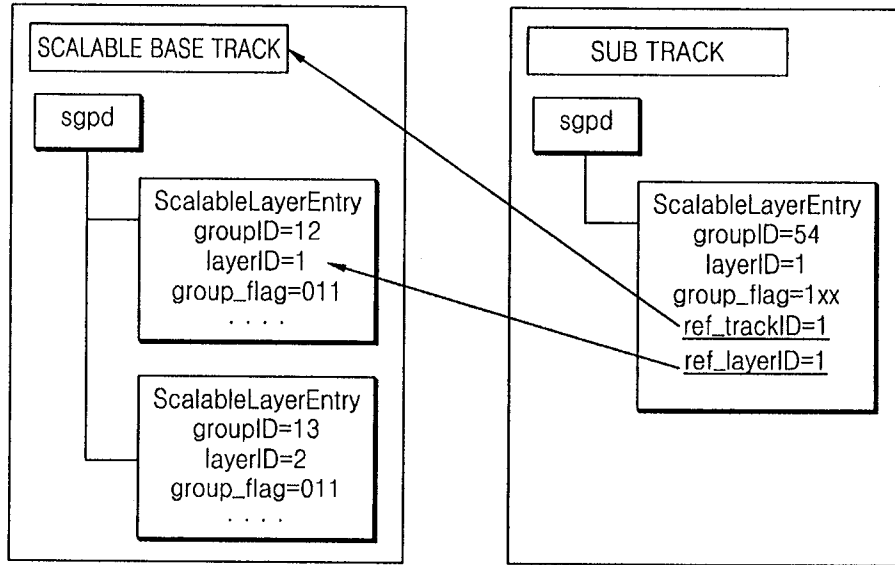

FIG. 6B

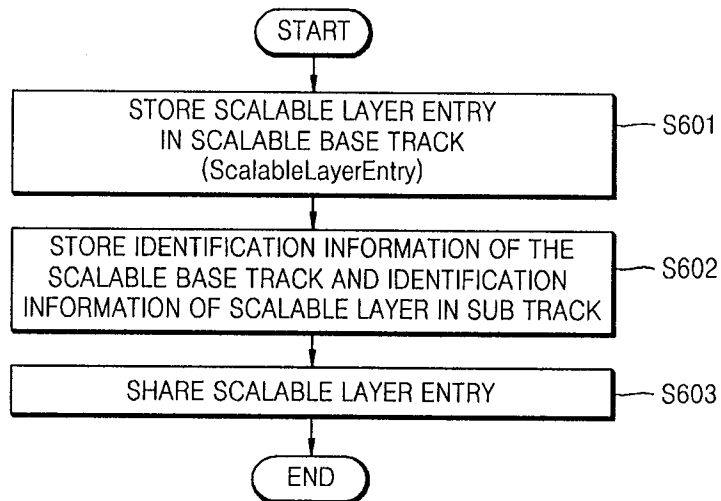

FIG. 7A

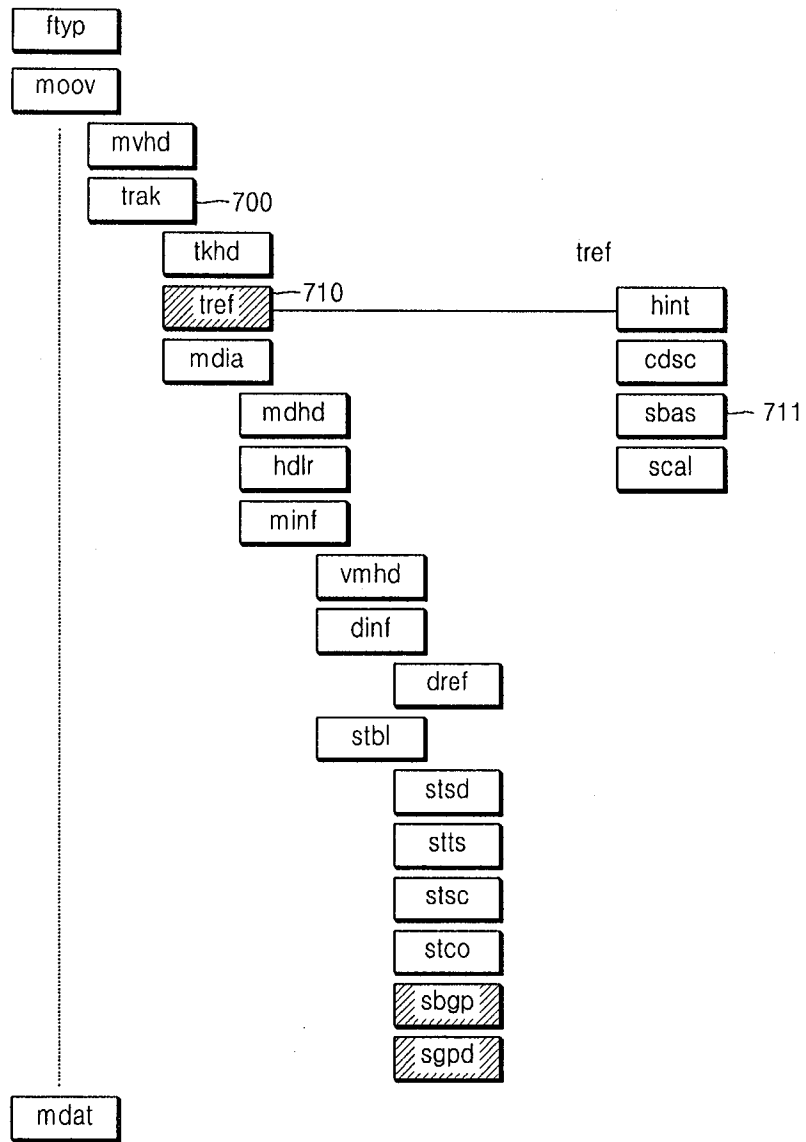
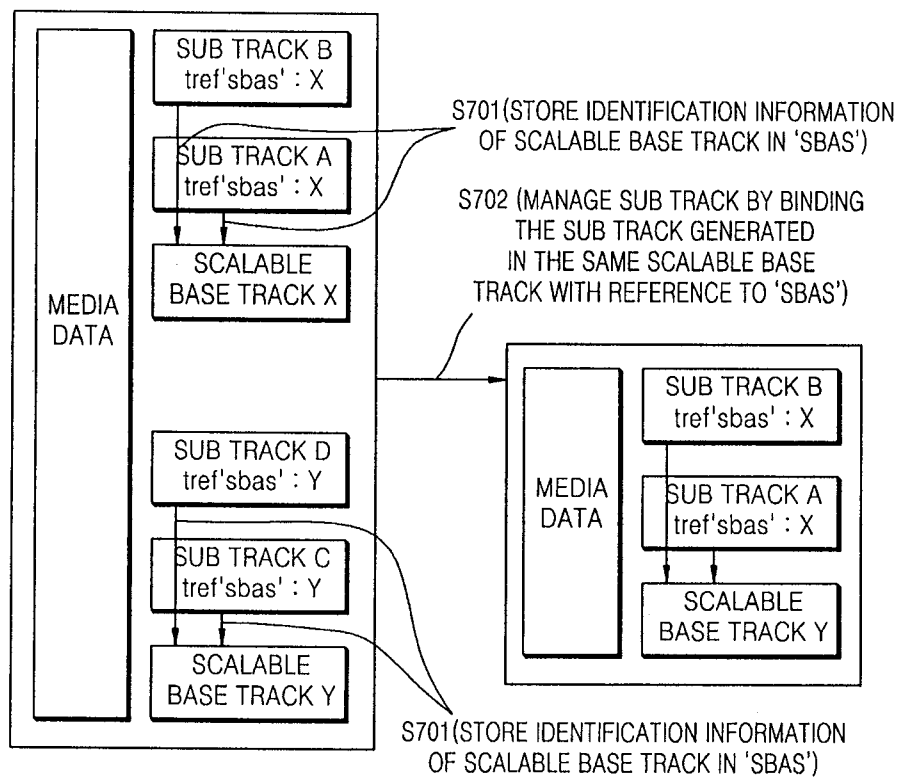

FIG. 7B



A. CLASSIFICATION OF SUBJECT MATTER**H04N 5/76(2006.01)i**

According to International Patent Classification (IPC) or to both national classification and IPC

B. FIELDS SEARCHED

Minimum documentation searched (classification system followed by classification symbols)

H04N

Documentation searched other than minimum documentation to the extent that such documents are included in the fields searched

Korean Patents and applications for inventions since 1975

Korean Utility models and applications for Utility models since 1975

Electronic data base consulted during the international search (name of data base and, where practicable, search terms used)

eKIPASS Search Terms: scalable video coding, svc, file, data

C. DOCUMENTS CONSIDERED TO BE RELEVANT

Category*	Citation of document, with indication, where appropriate, of the relevant passages	Relevant to claim No.
A	US 2003123546 A(FALIK YOHAI ET AL) 3 July 2003 See abstract and page 1, [0002]-page 2, [0027].	1-10
A	US 2005089105 A(ZHANG YA-QIN) 28 April 2005 See abstract and page 1, [0001]-page 3, line [0032].	1-10
A	US 2005117640 A(HAN, WOO-JIN) 02 June 2005 See abstract and page 1, [0001]-page 3, [0032].	1-10

 Further documents are listed in the continuation of Box C. See patent family annex.

* Special categories of cited documents:

"A" document defining the general state of the art which is not considered to be of particular relevance

"E" earlier application or patent but published on or after the international filing date

"L" document which may throw doubts on priority claim(s) or which is cited to establish the publication date of citation or other special reason (as specified)

"O" document referring to an oral disclosure, use, exhibition or other means

"P" document published prior to the international filing date but later than the priority date claimed

"T" later document published after the international filing date or priority date and not in conflict with the application but cited to understand the principle or theory underlying the invention

"X" document of particular relevance; the claimed invention cannot be considered novel or cannot be considered to involve an inventive step when the document is taken alone

"Y" document of particular relevance; the claimed invention cannot be considered to involve an inventive step when the document is combined with one or more other such documents, such combination being obvious to a person skilled in the art

"&" document member of the same patent family

Date of the actual completion of the international search

30 MARCH 2007 (30.03.2007)

Date of mailing of the international search report

30 MARCH 2007 (30.03.2007)

Name and mailing address of the ISA/KR

Korean Intellectual Property Office
920 Dunsan-dong, Seo-gu, Daejeon 302-701,
Republic of Korea

Facsimile No. 82-42-472-7140

Authorized officer

PARK, Jin Woo

Telephone No. 82-42-481-5765



INTERNATIONAL SEARCH REPORT

Information on patent family members

International application No.

PCT/KR2007/000166

Patent document cited in search report	Publication date	Patent family member(s)	Publication date
US2003123546A1	03.07.2003	AU2002360715A1	24.07.2003
		AU2002360715AA	24.07.2003
		US20030123546A1	03.07.2003
		US2003123546AA	03.07.2003
		W003058978A1	17.07.2003
		W02003058978A1	17.07.2003
US2005089105A1	28.04.2005	US06816194	09.11.2004
		US20020021761A1	21.02.2002
		US2002021761A1	21.02.2002
		US2002021761AA	21.02.2002
		US20050089105A1	28.04.2005
		US2005041745A1	24.02.2005
		US2005041745AA	24.02.2005
		US2005063463A1	24.03.2005
		US2005063463AA	24.03.2005
		US2005069036A1	31.03.2005
		US2005069036AA	31.03.2005
		US2005089105AA	28.04.2005
		US2005135477A1	23.06.2005
		US2005135477AA	23.06.2005
		US6816194BB	09.11.2004

(continued on the Supplemental sheet)

INTERNATIONAL SEARCH REPORT

Information on patent family members

International application No.

PCT/KR2007/000166

Patent document cited in search report	Publication date	Patent family member(s)	Publication date
US2005117640A1	02.06.2005	AU2004310915AA	16.06.2005
		AU2004310917AA	16.06.2005
		BR200417162A	06.03.2007
		BR200417189A	06.03.2007
		CA2547628AA	16.06.2005
		CA2547628A1	16.06.2005
		CA2547891AA	16.06.2005
		CA2547891A1	16.06.2005
		CN1625265A	08.06.2005
		CN1906945A	31.01.2007
		EP01538566A2	08.06.2005
		EP01538567A2	08.06.2005
		EP1538566A2	08.06.2005
		EP1538567A2	08.06.2005
		JP17168017	23.06.2005
		JP17168021	23.06.2005
		JP18333519	07.12.2006
		JP2005168017A2	23.06.2005
		JP2005168021A2	23.06.2005
		JP2006333519A2	07.12.2006
		KR1020050053469	08.06.2005
		KR1020050053470	08.06.2005
		KR2005053469A	08.06.2005
		KR2005053470A	08.06.2005
		MXPA06006107A	11.08.2006
		MXPA06006117A	11.08.2006
		US2005117640AA	02.06.2005
		US2005117647A1	02.06.2005
		US2005117647AA	02.06.2005
		US20060098169A1	11.05.2006
WO2005055606A1	16.06.2005		
WO2005055608A1	16.06.2005		