

(No Model.)

2 Sheets—Sheet 1.

D. M. MAXON.
VESSEL STEERING GEAR.

No. 526,930.

Patented Oct. 2, 1894.

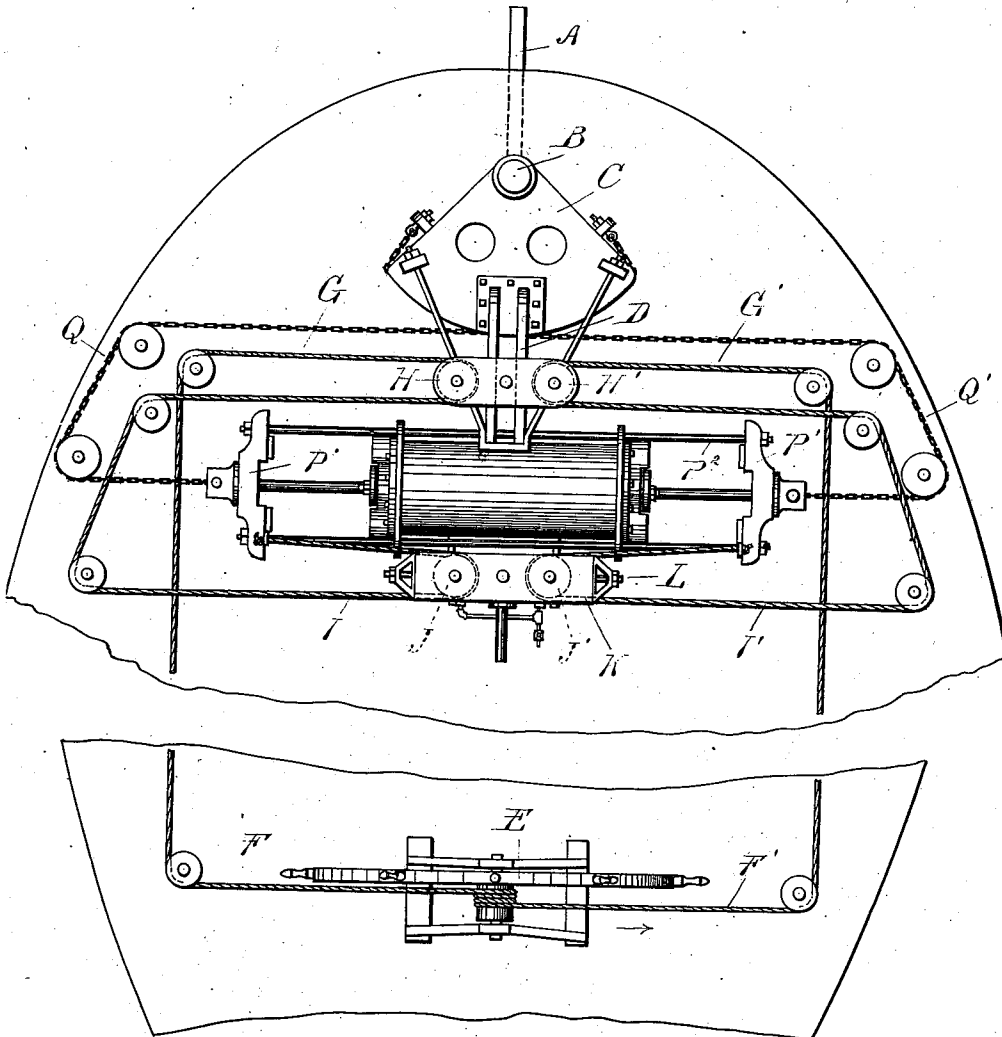

Fig. 1

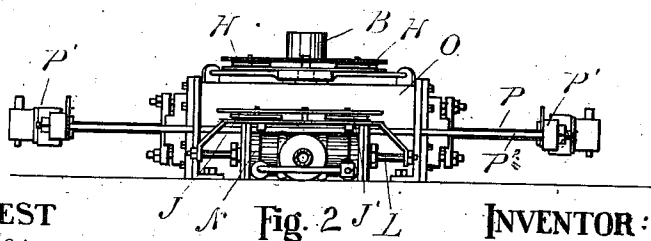

Fig. 2

ATTEST
J. B. Becklissinger
W. S. Sargent

INVENTOR:

Daniel M. Maxon
 By *W. S. Sargent* Atty.

(No Model.)

2 Sheets—Sheet 2.

D. M. MAXON.
VESSEL STEERING GEAR.

No. 526,930.

Patented Oct. 2, 1894.

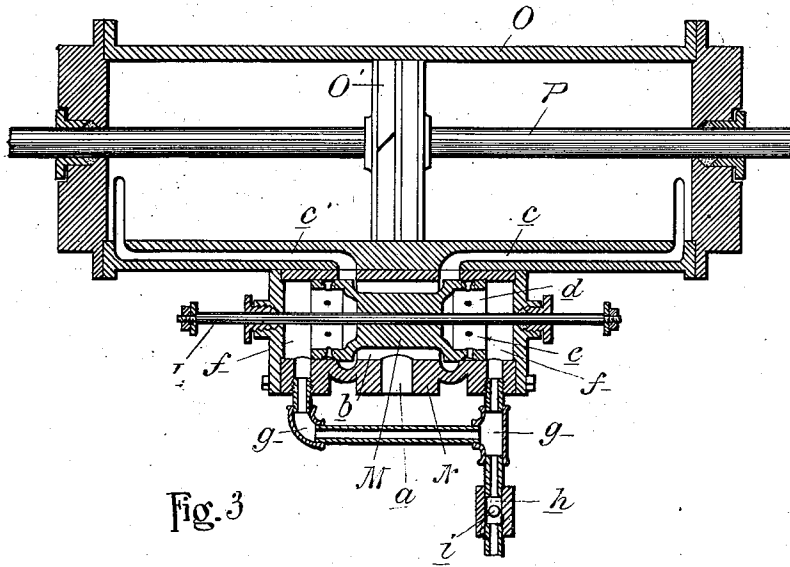

Fig. 3

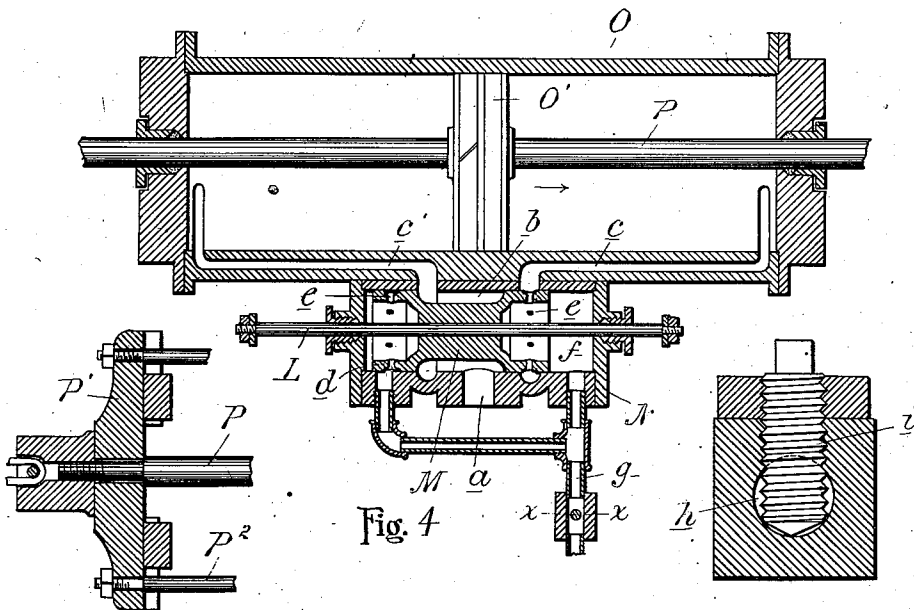

Fig. 4

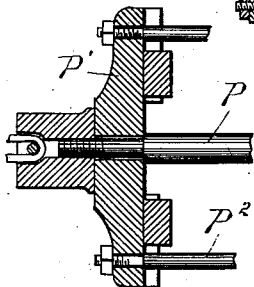

Fig. 5

ATTEST

D. D. Scribner
McDonogherty

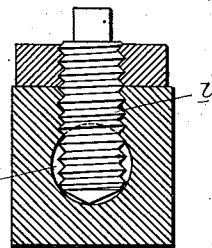

Fig. 6

INVENTOR:

Daniel M. Maxon
By McMagnum & Son Attys.

UNITED STATES PATENT OFFICE.

DANIEL MARSHMAN MAXON, OF BAY CITY, MICHIGAN, ASSIGNOR OF ONE-HALF TO WALTER H. WHITTEMORE, OF SAME PLACE.

VESSEL-STEERING-GEAR.

SPECIFICATION forming part of Letters Patent No. 526,930, dated October 2, 1894.

Application filed November 14, 1893. Serial No. 490,923. (No model.)

To all whom it may concern:

Be it known that I, DANIEL MARSHMAN MAXON, a citizen of the United States, residing at Bay City, in the county of Bay and State of Michigan, have invented certain new and useful Improvements in Vessel Steering-Gear, of which the following is a specification, reference being had therein to the accompanying drawings.

The invention consists in the peculiar construction of a steering gear comprising a power cylinder to which steam or other fluid is adapted to be fed to actuate the same, a valve controlling the fluid supply and connection between the valve and wheel; further in the peculiar construction and arrangement of the connecting mechanism between the wheel and power cylinder, the valve and the rudder, whereby in case the power devices break or become inoperative for any reason, the wheel may still be used to operate the rudder.

The invention further consists in the peculiar construction of the valve, and further in the construction, arrangement and combination of the various parts.

In the drawings, Figure 1 is a plan of my improved apparatus. Fig. 2 is a front elevation of the power cylinder and the connections to the rudder. Fig. 3 is a horizontal section through the cylinder and power valve. Fig. 4 is a similar section showing the valve in a different position. Fig. 5 is an enlarged section of one of the cross-heads on the end of the piston rod. Fig. 6 is a cross section on line x Fig. 4.

My invention belongs to that class of steering apparatus in which the valve is normally in such position that steam is admitted to both sides of the piston to balance the same and in which the movement of the valve opens the exhaust from one end of the cylinder thereby shifting the piston and the movement of the piston automatically returns the valve to its initial position, balancing the piston in its new position thereby not only serving to actuate the rudder but to hold it fixed at every point of its adjustment.

A is the rudder; B, the post; C, the quadrant thereon; D, a lever or arm extending forwardly from the quadrant and forming

the actuating arm or lever for operating the rudder.

E is the usual wheel in the pilot house or any other suitable point, which is provided with a hub about which the cables F F' are wound in opposite directions. These cables extend over suitable sheaves to the stern of the boat where they are provided with loops G and G' respectively, which pass over sheaves H H', which are secured to the arm D. From thence they pass over suitable sheaves into proximity to the power cylinder and there they are formed into loops I I', which pass respectively over the sheaves J J', which are secured to the frame K, attached to the ends of the stem L, which extends both ways from the valve M in the valve cylinder N.

The frame K is formed of rigid material and spans the valve casing, its outer end being rigidly connected to the opposite ends of the valve stem L, so that as the frame is moved, the stem and its valve are correspondingly moved, the extent of the movement being limited by the extent of the movement of the valve.

O is the power cylinder in which is the piston O' from which extends the piston rod P through both ends.

P' are cross-heads on the ends of the piston rod and P² are guide rods secured to the ends of the cross-heads and serving to guide it in guide ways formed on the sides of the power cylinder.

Q Q' are cables or chains secured at one end to the cross-heads and at their other ends secured (from opposite sides) to the quadrant passing over suitable intermediate sheaves, so that motion of the piston in its cylinder in either direction will correspondingly move the rudder.

The valve cylinder is provided centrally with an inlet port a communicating with any source of fluid supply under pressure. Centrally around the valve M is an annular passage b of sufficient length so that when the valve is in its normal central position, as shown in Fig. 3, the passage way b will connect into the ports c c' which connect respectively to opposite ends of the cylinder O.

The valve is provided with the tubular

heads *d* having a series of restricted apertures *e* therein, adapted to be registered with the ports *c c'* which form exhaust ports through the valve and connect the cylinder through the exhaust chambers *f* with the exhaust pipe *g*. This exhaust pipe is provided at some suitable point with a restricted port or passage way *h* which I preferably form so that it may be adjusted. This may be accomplished, as shown in Fig. 6, by means of a screw *i* extending across the exit pipe *g* and adapted to be adjusted more or less therein.

The parts being thus constructed their operation is as follows: In Fig. 3 the valve and piston are shown in their normal position with the rudder in its central position. It will be seen by inspection of this figure that the valve is located centrally of the valve chest and the steam from the boiler can pass through the port *a*, through the annular port *b* around the valve and to the opposite ends of the cylinder through the ports *c c'*, balancing the pressure upon opposite sides of the piston. Now if it is desired to change the course of the boat, the operator turns the wheel in the ordinary manner. The wheel being turned in the direction of the arrow (Fig. 1) will draw upon the cable *F* and slacken the cable *F'* correspondingly, the sheaves *H H'* remaining stationary. The cables will run over those sheaves without affecting the rudder, while the sheaves *J J'* will be shifted laterally by the movement of the cable, which will shift the valve in the valve chest to the position shown in Fig. 4. This connects the right hand end of the cylinder with the exhaust pipe through the ports *e* and maintains the left hand end of the cylinder in communication with the steam pressure. The result will be that the piston will be moved to the right correspondingly turning the rudder through the chains *Q Q'*. Now if the wheel be stopped after a short movement the shifting of the piston, and through the connection described, the cross-heads *P'* will shift the valve *M* correspondingly through the loops *I I'* and sheaves *J J'*, for it will be evident that if the cables at the wheel end are held firmly and the cross-heads *P'* are moved it can only be accomplished by a lateral movement of the valve through the connections described. As soon as the valve has been moved in this manner to its middle position, the exhaust will be cut off and steam pressure will be applied to the opposite sides of the piston which will hold it in its adjusted position. In case the steam should be shut off from the power cylinder, the connections of the cables described will permit of the operating of the rudder from the wheel without in any way changing the same. This is accomplished by the necessarily limited movement of the frame *K* which is carried by the valve stem *L*. As one of the cables is wound on the drum and the other slackened, the frame *K* will be checked in its movement by the limited play of the rod *L* and thereby form a fixed fulcrum, over which

the cable passes. The continued drawing movement of the cable will necessarily move the cross head and thereby the rudder. This construction and arrangement of parts enables me to apply my device without any particular change to boats already equipped with the hand steering apparatus, without interfering with the ordinary use of such hand steering apparatus when desired and yet give an exceptionally efficient steam steering apparatus.

By restricting the exhaust I make the movement of the rudder steadier and prevent the possibility of racing of the piston and the too sudden shifting of the rudder.

What I claim as my invention is—

1. In a steering gear, the combination of a power cylinder, a piston therein, a valve to control said piston having supply ports to admit pressure to both sides of the piston at the same time, connections from the opposite ends of the piston to the rudder, a steering wheel, connections from the wheel to the opposite ends of the valve and the piston, substantially as described.

2. In a steering gear, the combination with the rudder, of a power piston for actuating the same, a cylinder in which said piston is located, a controlling valve for the cylinder having supply ports for admitting equal pressure to both sides of the piston, a restricted exhaust passage from the cylinder, and a wheel for actuating the valve, substantially as described.

3. In a steering gear, the combination with a wheel, a rudder, and a valve controlled power cylinder, of cable connection from the wheel on opposite sides, sheaves on the tiller on which said cable is looped, sheaves on the valve operating bar over which said cable is looped, and a piston rod extending both sides of the piston to the ends of which the opposite ends of the cables are secured, substantially as described.

4. In a steering gear, the combination of a power cylinder, a piston therein, connections from the piston to the rudder, a valve chamber, a valve having ports adapted to admit steam to both sides of the piston at the same time, a piston rod extending through both ends of the valve chamber, a plate connecting the opposite ends of the rod beside the valve chamber, sheaves on the plate, and cables from the rudder passing in opposite directions around the sheaves and connected to opposite ends of the piston rod of the power piston, substantially as described.

5. In a steering gear, the combination of a power cylinder, a piston therein connected from opposite sides to opposite sides of the rudder quadrant, a valve controlling the admission of fluid to the cylinder, a wheel, and connection from the wheel to the rudder, valve and piston, whereby the wheel may be used to operate the valve or the rudder, substantially as described.

6. In a steering gear, the combination of the

power cylinder, a valve chamber, the valve
M therein, having tubular heads *d* provided
with a series of restricted ports *e*, ports con-
trolled by the valve to admit steam to both
5 ends of the cylinder at the same time, and
means for actuating the valve, substantially
as described.

In testimony whereof I affix my signature in
presence of two witnesses.

DANIEL MARSHMAN MAXON.

Witnesses:

CHAS. W. ORTON,
JOHN B. KANOUSE.