

No. 646,583.

Patented Apr. 3, 1900.

S. W. McMUNN.
CAR TRUCK.

(Application filed June 28, 1899.)

(No Model.)

2 Sheets—Sheet 1.

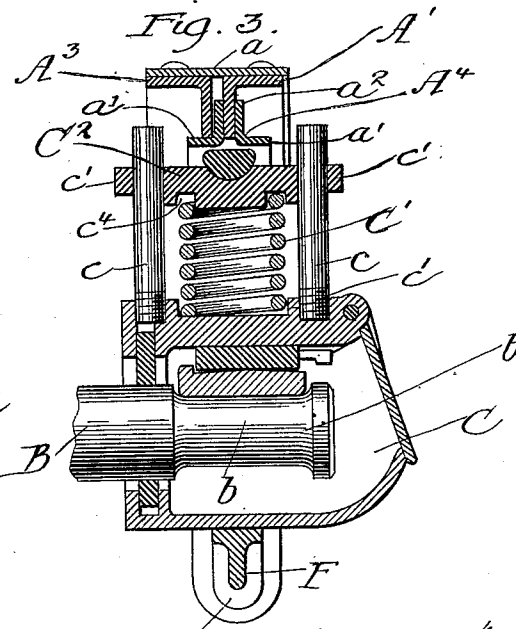
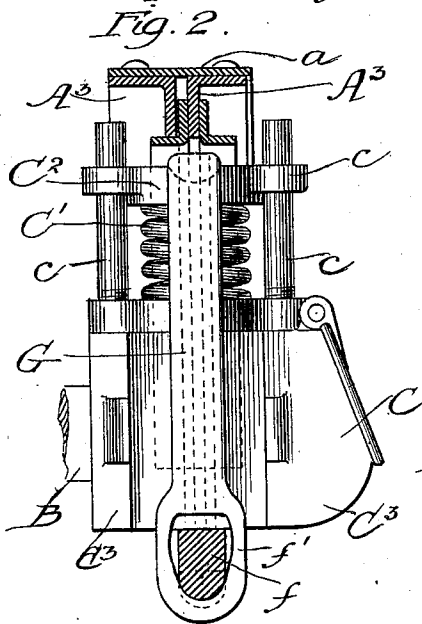
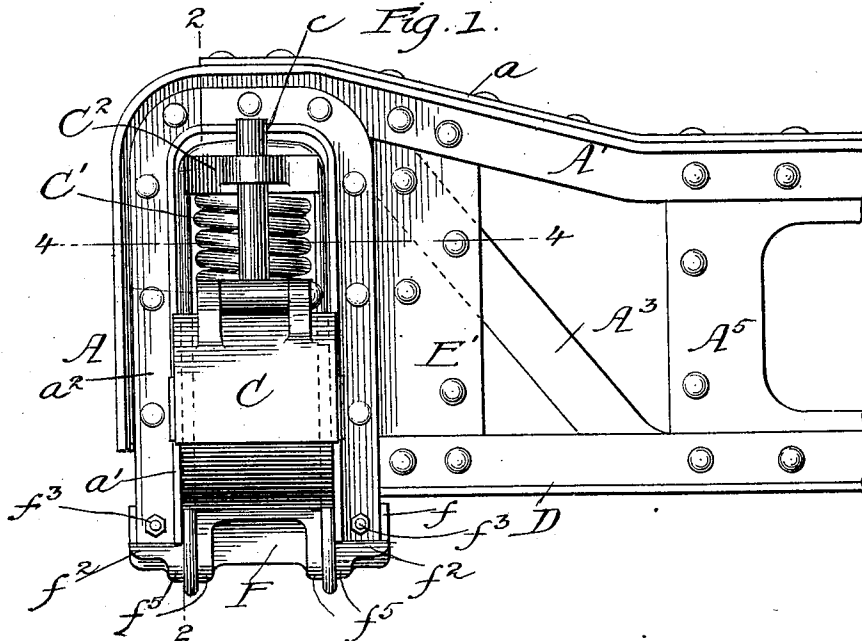

Witnesses:

f⁵ Inventor:

Samuel Worthington McMunn

C. W. Fiees

By Attorneys

C. A. Crawford

Poole & Brown

No. 646,583.

Patented Apr. 3, 1900.

S. W. McMUNN.
CAR TRUCK.

(Application filed June 28, 1899.)

(No Model.)

2 Sheets—Sheet 2.

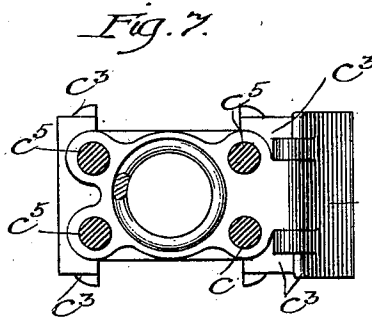
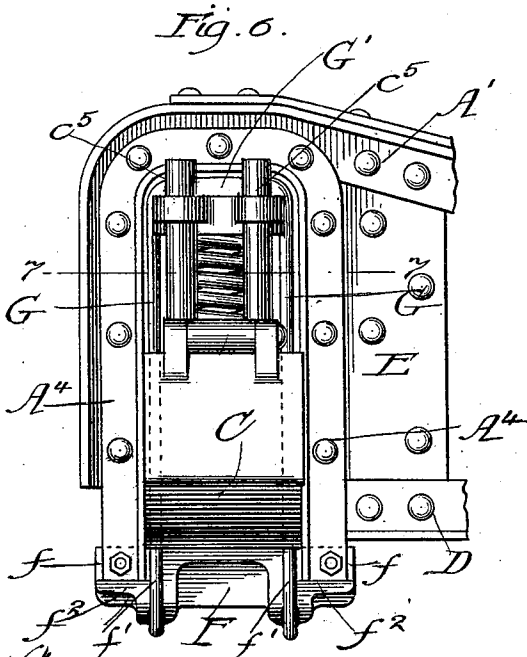
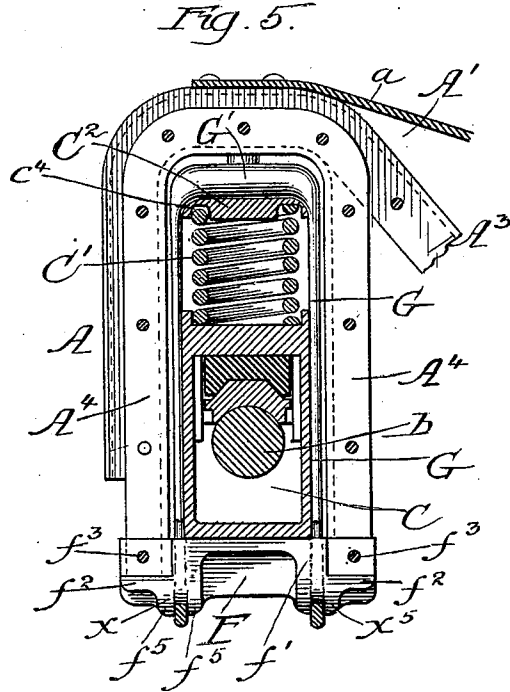
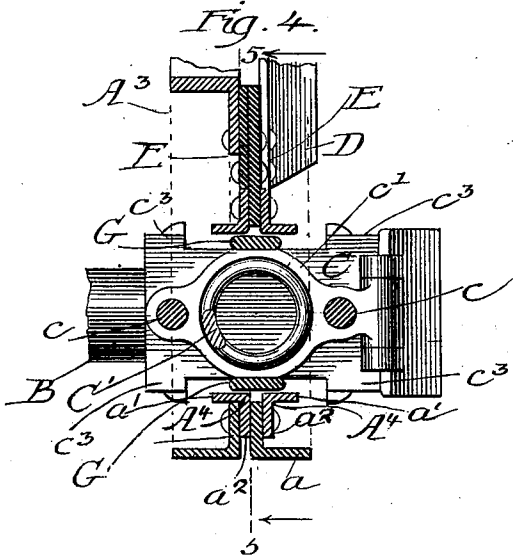

Witnesses:

Frank D. Blanchard
Carl H. Crawford

Inventor:

Samuel Worthington McMunn

By Attorneys

Poole + Brown

UNITED STATES PATENT OFFICE.

SAMUEL WORTHINGTON McMUNN, OF CHICAGO, ILLINOIS.

CAR-TRUCK.

SPECIFICATION forming part of Letters Patent No. 646,583, dated April 3, 1900.

Application filed June 28, 1899. Serial No. 722,130. (No model.)

To all whom it may concern:

Be it known that I, SAMUEL WORTHINGTON McMUNN, of Chicago, in the county of Cook and State of Illinois, have invented certain new and useful Improvements in Car-Trucks; and I do hereby declare that the following is a full, clear, and exact description thereof, reference being had to the accompanying drawings, and to the letters of reference marked thereon, which form a part of this specification.

This invention relates to improvements in railway-car-truck frames of that class in which the truck-frame is supported on journal-boxes by means of supporting-links pivotally connected at their upper ends with the journal-box and at their lower ends to the truck-frame, so as to permit lateral movement in oscillation of the frame with respect to the car-wheel axles, such lateral movement of the car-truck being intended to lessen or prevent excessive lateral pressure of the wheel-flanges against the rails and consequent wear of the wheel-flanges.

The invention consists in the matters hereinafter set forth, and more particularly pointed out in the appended claims.

In the drawings, Figure 1 is a fragmentary side elevation of a device embodying my invention. Fig. 2 is a section taken on line 2 2 of Fig. 1. Fig. 3 is a section taken on line 3 3 of Fig. 1. Fig. 4 is a section taken on line 4 4 of Fig. 1. Fig. 5 is a section taken on line 5 5 of Fig. 1. Fig. 6 is a side elevation of a modified form of a device embodying my invention. Fig. 7 is a section taken on line 7 7 of Fig. 6.

In the particular embodiment of my invention illustrated in said drawings, A indicates as a whole a car-truck pedestal, B a car-axle provided with a journal *b*, and C an axle-box of familiar construction. The said pedestal is provided in the usual manner with a downwardly-opening recess, in which the axle-box is located.

C' indicates a spring through which the truck is supported on the axle-box, said spring being of the familiar spiral form and being interposed between the top of the axle-box and a cap C², located over the box. The top wall of the axle-box is provided with an elevated annular rib or flange *c'*, forming a re-

cess to receive the lower end of the spring C', whereby the same is held from lateral displacement. In the lower surface of the cap C² is formed an annular groove *c*⁴ to receive the upper end of the spring, said groove holding the said upper end of the spring in proper position with respect to said cap.

F indicates a pivot-bar which is attached at its ends to the lower part of the pedestal, at either side of the opening therein, and G G indicate two supporting-links which are pivotally engaged at their lower ends with the pivot-bar and are rigidly connected at their upper ends by a cross-bar G', by which said links are pivotally connected with the cap C². Said links support the truck upon the axle-box and at the same time afford lateral movement of the truck-frame with respect to the axle and wheels, so as to prevent excessive side pressure of the wheel-flanges against the rails, the pivotal connection of the links at their upper ends with the cap and at their lower ends with the truck-frame permitting the latter to swing or oscillate freely in a lateral direction within the limited range of movement necessary for securing the desired results. Said journal-box is provided at its inner and outer ends with rigidly-attached upright guide-standards *c c*, which have guiding engagement with the cap C², preferably by means of apertured lugs *c' c'* on the cap, which project from the inner and outer margins of said cap and are engaged by said guide-standards. Said guide-standards serve to hold the cap and the upper part of the spring from lateral displacement with respect to the axle-box, while permitting the cap to move vertically with respect to the axle-box as the spring expands and contracts under the action of the load thereon. The guide-standards arranged as described perform the important function of holding the cap and upper part of the spring at all times vertically over the axle-box, notwithstanding the horizontal inward or outward strain brought on the cap by the supporting-links when the latter is thrown into an inwardly or outwardly inclined position in the lateral oscillating movements of the truck from its central or normal position.

For the purpose of limiting the lateral movement of the truck with respect to the axle-box the guide-standards *c c* are extended

above the guide-lugs on the cap sufficiently far to engage the part of the pedestal above the cap, the upper ends of said standards constituting stops, which by coming in contact with the outer or inner face of the truck prevent the truck from swinging or oscillating to a greater extent than is desirable or necessary. The action of said standards in this respect is supplemented by stop projections, lugs, or flanges $c^3 c^3$ on the side faces of the axle-box, the same being so located as to come in contact with the side portions of the pedestal, at the inner or outer face of the said pedestals, at the same time that the upper ends of the guide-standards strike the upper part of the pedestal.

The supporting-links $G G$ and the cross-bar G' are made integral with each other, the links and cross-bar thus forming an inverted stirrup. The pivotal connection between said links and the cap is secured by the provision of a groove in the top surface of the cap, in which the cross-bar G' rests, the lower surface of the cross-bar being rounded or made of parti-cylindric form and the groove in the cap of corresponding shape. The stirrup is made from a single flat piece of metal bent in the direction of its least dimension into U form and corresponding in general proportions with the inner dimensions of the pedestal. The lower ends of the side pieces or links $G G$ are increased in width laterally, and each is provided with an aperture which is semicircular in its lower part and which engages the pivot-bar F , which passes through said aperture. Said bar is rounded on its lower surface at its end portions which are engaged by the links, said rounded portions fitting the semicircular parts of the apertures of the links. The links $G G$ fit closely to the sides of the axle-box, thereby serving as guides therefor and preventing horizontal movement of the axle-boxes in a lateral direction with respect to the car-axles.

The pedestal A illustrated consists, mainly, of two like metal bars $A^4 A^4$ of inverted- U shape arranged parallel with each other and the inner faces of which constitute the walls of the pedestal-opening, and the pivot-bar F has special features of construction adapting it for attachment to a pedestal so constructed. The said bars $A^4 A^4$, while rigidly attached to each other by rivets or the like, are separated from each other by a narrow space, and the lower extremities thereof extend below the main parts of the truck-frame of which the said bars form a part. The pivot-bar F is provided at its ends outside of the semicircular bearings for the links $G G$ with lateral recesses forming central vertical webs $f f$, adapted for insertion between the lower separated ends of the pedestal-bars $A^4 A^4$, and also forming at either side of the bar outwardly-facing shoulders $f' f'$ and upwardly-facing shoulders $f^2 f^2$. The lower ends of said pedestal-bars $A^4 A^4$ are inserted in said recesses with the web f between the same,

and the pivot-bar is secured to the said pedestal-bars by bolts $f^3 f^3$, inserted through said parts. The outward-facing shoulders $f' f'$ abut against the inner faces of the pedestal-bars and, in connection with the bolts $f^3 f^3$, serve to rigidly connect and hold from relative movement the lower ends of said pedestal-bars. The upwardly-facing shoulders $f^2 f^2$ abut against the lower ends of the pedestal-bars and serve to take the vertical strain due to the weight of the car and its load, which is transmitted to the axles through the medium of said pivot-bar and the links which connect it with the axle-box. Preferably the central part of the pivot-bar is made relatively thin or light and of flanged form, as seen in the sectional view Fig. 3. Preferably, also, the end portions of the pivot-bar are provided with depending transverse flanges $f^5 f^5$ at either side of the links $G G$, said flanges forming transverse grooves in which the lower ends of the links are located and by which the links are held from moving or shifting from their proper places on the bar. The openings or eyes in the lower ends of the links are made vertically deep enough to permit the removal and insertion therethrough of the enlarged end portions of the pivot-bar outside of the said grooves.

The truck-frame illustrated is an open truss-frame made or built up of channel-bars, angle-bars, and plates and is like that shown in an application for patent, Serial No. 702,941, filed by Dwight Bruce Kennedy January 21, 1899. Said truck-frame illustrated embraces an upper or compression member A' , the end of which is extended over the top of and downwardly at the outer side of the pedestal and which consists of an angle-bar having its web portion arranged vertically and inserted between the bars $A^4 A^4$ of the pedestal; a tension member which extends beneath the transom A^5 of the truck, is deflected upwardly to the top of the pedestal, and extends over the top and downwardly at the outer side of the pedestal, with its end portion parallel with that of the compression member A' ; a horizontal tie-bar D , which is secured to the end of the transom and extends at its end to the inner vertical parts of the pedestal-bars A^4 ; a vertical plate E , which abuts at its upper end against the compression member A' , is attached at its lower end to the tie-bar D , and at its outer edge is inserted between and secured to the pedestal-bars $A^4 A^4$; a second vertical plate E' , which is arranged in contact with and inside of the plate E and extends at its upper end between and is secured to the tension and compression members A' and A^3 , and a top plate a , which is applied over the top of and connects the transom and the tension and compression members, these several parts being connected by rivets, as shown.

The pedestal-bars $A^4 A^4$ preferably consist of angle-bars having their web portions a^2 vertical and adjacent to each other and their

flanges *a'* located at the inner margins of said web portions and outwardly and inwardly directed, said flanges together forming the flat walls of the pedestal-opening, as clearly shown in Figs. 2, 3, and 4.

An important advantage is gained by the employment of guide-standards located at the front and rear of the axle-box and engaging the cap in the manner described, for the reason that the guide-standards thus arranged serve to properly guide and hold in place the cap, while at the same time they do not in any way interfere with the spring and enable a spring to be used of the largest diameter possible, taking into consideration the space afforded between the links G G for said spring. It is important that the parts should be so arranged as to permit the use of the largest possible spring, for the reason that a coiled spring of large diameter affords greater resiliency with the same strength, or, in other words, is less liable to become permanently set (or its limit of elasticity is liable to be reached) when greatly compressed by the jarring of the car under heavy loads. The feature of construction by which the upper ends of the said guide-standards are arranged in position to strike the pedestal, and thereby form stops to limit the lateral oscillation of the truck, is also an advantage, for the reason that the guide-bars thus arranged serve to positively limit the lateral movement both of the cap and the box itself with respect to the truck. An advantage is also obtained from the use of the stop-flanges on the sides of the axle-box in combination with the standards when both of these parts are located in position to strike the truck-frame at the same time, as hereinbefore described, for the reason that this construction avoids any tendency to tip or tilt the axle-box and insures an upright position thereof at such times as said parts may come in contact with the truck-frame in the lateral oscillation of the latter.

Another important feature of my invention is embraced in the construction of the pivot-bar F in connection with a truck constructed with two pedestal-bars in the manner described in view of the fact that the said upwardly-facing shoulders on the pivot-bar serve by their contact with the lower ends of said pedestal-bars to take the strain coming on the connection between the pedestal-bars and pivot-bar, thereby relieving the connecting-bolt of such strain and affording an exceedingly strong and reliable connection between the parts.

A modification of my invention is shown in Figs. 6 and 7, in which two vertical guide-bars *c⁵ c⁵*, &c., are secured at each end of the journal-box, the same being arranged in the manner heretofore described to engage apertured lugs on the inner and outer margins of the cap and to engage the pedestal in the same manner as in the case of the guide-bars *c c*.

While the invention is shown in the draw-

ings in connection with an open-truss truck-frame constructed of bars and plates, it is obvious that the same may be used in connection with any desired truck-frame having a pedestal adapted to receive within the same the elements constituting the device.

I claim as my invention—

1. The combination with a car-truck and a journal-box of a supporting-spring, a cap, suspension-links pivotally connecting said cap with the trucks, and a guide arm or standard on the inner and outer ends of the journal-box and extended above the pedestal-opening and having guiding engagement with said cap.
2. The combination with a car-truck, and a journal-box, of a supporting-spring, a cap, suspension-links pivotally connecting said cap with the truck, and vertical guide-bars on the journal-box having guiding engagement with said cap, said guide-bars being extended above the cap in position for contact with the portion of the truck above said cap.
3. The combination with a car-truck, and a journal-box, of a supporting-spring, a cap, suspension-links pivotally connected with said cap with the truck, upright guide-standards attached to the journal-box and having guiding engagement with said cap, the upper ends of said standards being located in position for contact with the truck-frame, said box being provided with lateral flanges adapted for engagement with the side faces of the truck at the same time that the standards come in contact with the said truck.
4. The combination with a car-truck, provided with two parallel, U-shaped pedestal-bars and a journal-box, of a pivot-bar attached at its ends to the lower ends of said pedestal-bars, said pivot-bar having at its ends vertical webs which enter between the lower ends of the pedestal-bars and having also upwardly-facing shoulders at either side of said web adapted to engage the lower ends of said pedestal-bars, and links pivotally supporting the truck on the journal-box, said links being engaged at their lower ends with said pivot-bar.
5. The combination with a car-truck provided with two parallel, U-shaped pedestal-bars, and a journal-box, of a pivot-bar attached at its ends to the lower end of the said pedestal-bars, said pivot-bar being provided at its ends with vertical webs which enter between the lower ends of the pedestal-bar and at either side of said webs with upwardly-facing shoulders and also with outwardly-facing shoulders, said upwardly and outwardly facing shoulders being adapted to bear against the end portions of the pedestal-bars, links by which the truck is supported upon the journal-box, said links being engaged at their lower ends to the said pivot-bar.
6. The combination with a car-truck having two parallel U-shaped pedestal-bars, of a journal-box, a pivot-bar attached at its ends

to the lower ends of said pedestal-bars and links for supporting the truck from the journal-box, said links being provided at their lower ends with apertures to engage the pivot-bar said pivot-bar being provided adjacent to its ends with semicylindric bearing-surfaces and with transverse flanges at either side thereof forming transverse grooves to receive the lower ends of the links, and said pivot-bar being provided also, outside of said grooves, with vertical webs which enter between the said pedestal-bars, and at either side of said webs with upwardly-facing shoulders which bear against the lower ends of the pedestal-bars.

7. The combination with a car-truck pedestal and a journal-box, of a supporting-spring, a cap in contact with the upper end of said spring, said cap being provided with a transverse groove in its upper surface, supporting-links connected at their upper ends by a cross-bar which is made integral therewith and is provided with a rounded lower surface engaging the grooves in said cap, a pivot-bar attached at its ends to the sides of the pedestal, and with which the lower ends of said links are engaged, and guide-standards on the inner and outer ends of, and extended above the journal-box through guide-openings in said cap.

8. The combination with a car-truck pedestal and a journal-box, of a pivot-bar attached at its ends to the sides of the pedestal, a supporting-spring located over the journal-box, a cap provided with outwardly-projecting apertured lugs at its outer and inner

margins, guide-standards on the outer and inner ends of the box passing through the apertures in said lugs, and supporting-links pivotally connected with said cap and with the pivot-bar.

9. The combination with a car-truck pedestal and a journal-box, of a pivot-bar attached at its ends to the sides of the pedestal, the supporting-spring of spirally-coiled form, a cap resting on the top of the spring, said cap being provided on its upper surface with a bearing-groove and at its inner and outer sides with apertured lugs, supportingly connected at their upper ends by a cross-bar which engages said groove, said links being located closely adjacent to the sides of the pedestal, a pivot-bar attached at its ends to the sides of the pedestal and engaging the lower ends of said links and guide-standards on the inner and outer ends of the journal-box and extending upwardly therefrom in guiding engagement with the apertured lugs of said cap, the axle-box being constructed to fit closely between the links, and the spring being made of coiled form and of a diameter approximating the space between the said links.

In testimony that I claim the foregoing as my invention I affix my signature, in presence of witnesses, this 23d day of June, A. D. 1899.

SAMUEL WORTHINGTON McMUNN.

Witnesses:

EDWIN S. WOODS,
C. E. WILLIAMS,
CHARLES W. HILLS.