

(19) **DANMARK**



Patent- og  
Varemærkestyrelsen

(10) **DK/EP 3455705 T3**

(12) **Oversættelse af  
europæisk patentskrift**

- 
- (51) Int.Cl.: **G 06 F 3/041 (2006.01)** **B 25 J 13/08 (2006.01)** **G 06 F 3/042 (2006.01)**
- (45) Oversættelsen bekendtgjort den: **2022-01-31**
- (80) Dato for Den Europæiske Patentmyndigheds bekendtgørelse om meddelelse af patentet: **2021-11-17**
- (86) Europæisk ansøgning nr.: **17735666.4**
- (86) Europæisk indleveringsdag: **2017-04-27**
- (87) Den europæiske ansøgnings publiceringsdag: **2019-03-20**
- (86) International ansøgning nr.: **TR2017050168**
- (87) Internationalt publikationsnr.: **WO2017196281**
- (30) Prioritet: **2016-05-13 TR 201606370**
- (84) Designerede stater: **AL AT BE BG CH CY CZ DE DK EE ES FI FR GB GR HR HU IE IS IT LI LT LU LV MC MK MT NL NO PL PT RO RS SE SI SK SM TR**
- (73) Patenthaver: **Sensobright Industries, LLC, 160 Greentree Dr Ste 101 , Dover City, Kent County, DE 19904, USA**
- (72) Opfinder: **Buyuksahin, Utku, , 34742 Istanbul, Tyrkiet**
- (74) Fuldmægtig i Danmark: **GUARDIAN IP CONSULTING I/S, Diplomvej 381, 2800 Lyngby, Danmark**
- (54) Benævnelse: **ET BERØRINGS- OG TRYKFØLESYSTEM MED FORSKELLIGE ØVRE LAG**
- (56) Fremdragne publikationer:  
**WO-A1-2005/029028**  
**US-A- 4 547 668**  
**US-A- 4 816 811**  
**US-A1- 2012 303 839**  
**US-A1- 2015 109 607**  
**US-A1- 2015 217 781**  
**BUYUKSAHIN UTKU ET AL: "Multi point, high sensitive tactile sensing module for robots and devices", IEEE SENSORS 2014 PROCEEDINGS, IEEE, 2 November 2014 (2014-11-02), pages 366-369, XP032705477, DOI: 10.1109/ICSENS.2014.6985010 [retrieved on 2014-12-12]**  
**LANG P ED - CHERITI A ET AL: "Design and prototyping of a fiber optic tactile array", ELECTRICAL AND COMPUTER ENGINEERING, 2008. CCECE 2008. CANADIAN CONFERENCE ON, IEEE, PISCATAWAY, NJ, USA, 4 May 2008 (2008-05-04), pages 373-376, XP031285989, ISBN: 978-1-4244-1642-4**  
**PETER KAMPMANN ET AL: "Integration of Fiber-Optic Sensor Arrays into a Multi-Modal Tactile Sensor Processing System for Robotic End-Effectors", SENSORS, vol. 14, no. 4, 16 April 2014 (2014-04-16) , pages 6854-6876, XP055408102, DOI: 10.3390/s140406854**



# DESCRIPTION

## Relevant Technical Field

[0001] The present invention relates to sensing systems that are used especially in robotic systems.

## Background Art

[0002] In order to explore those areas which may be dangerous for human (for example, different planets, underground tunnels or caves), exploration robots are used. Exploration robots comprise various sensors for detecting objects in the area they are sent and for identifying the characteristics of the said objects. One of the sensors used in the said exploration robots is tactile sensors. By means of the tactile sensors, presence of certain objects and some physical features thereof such as pressure can be detected.

[0003] The conventional tactile sensors comprise a light source positioned under an elastic surface and a light sensing element for sensing the amount of the light reflected from the said surface, as disclosed in US2010155579A1. In such tactile sensors, when a force is applied on the elastic surface, the said surface approaches to the light source and the light sensing element. As a result of such approach, the amount of light incident on the light sensing element increases. The amount of light sensed by the light sensing element and resilience properties of the surface are used to calculate the amount of force applied to the surface. However, in this embodiment, the number of light sources that may be positioned under the unit surface and of the light sensing elements are limited, and it is cumbersome to process data received from a high number of light sensing elements.

[0004] Said problems are solved by a module disclosed in WO2014011126A1. The said module comprises an elastic material, which is covered with a layer providing light reflection; a CMOS or CCD image sensor; at least one light source; a plurality of first fiber optic cables, a tips of which are separated from surrounding environment via said layer by being located under the layer and other tips of which are in connection with said light source, wherein said first fiber optic cables carry light beams from the light source to said layer; a plurality of second fiber optic cables, a tips of which are separated from surrounding environment via said layer by being located under the layer and being directed towards the layer and other tips of which are in connection with said image sensor so that each second fiber optic cable is paired with one pixel of the image sensor, wherein light beams reflected from the layer are transferred to the image sensor by said second fiber optic cables; a processor which calculates every individual force applied to the layer according to light intensity changes of each pixel connected with a second fiber cable, of a photo frame generated by the image sensor in response to the displacement of the layer by using image processing techniques. In the module disclosed in

WO2014011126A1, when the elastic material contacts to an object, a deformation is generated in the elastic material and the said layer (e.g. displacement of the layer towards the fiber optic cables). As a result of such displacement, the amount of light reflected from the layer to the fiber optic cable is changed. Said change in the amount of light is detected as a color change in the photo frame generated in the image sensor. The processor applies image processing techniques to the said photo frame so as to measure color changes of the photo, and thus the amount of displacement of the layer. Based on the amount of displacement calculated, the force applied on the elastic material is also calculated. However, due to the fact that in the said embodiment detection is only performed based on the level of light, an improvement is needed.

**[0005]** Another patent document US4547668A discloses a two-dimensional pressure sensor. Said pressure sensor comprises a light source; a matrix of light transmitting fiber endings comprising a plurality of fibers for transmitting said light from said light source and a plurality of fibers for receiving reflected light; a transmitting fiber sub-array comprising endings of said transmitting fibers located a distance from said matrix of light transmitting fiber endings, said endings located to receive light from said light source; a receiving fiber sub-array, comprising endings of said receiving fibers located a distance from said matrix of light transmitting fiber endings; a retro-reflective material located a distance above said matrix; a semi-transparent deformable medium located between said matrix and said retro-reflective material, said semi-transparent deformable medium supporting said retro-reflective material; a flexible membrane located adjacent said retro-reflective material side farthest from said matrix; and means located adjacent said receiving fiber sub-array, for detecting said reflected light transmitted by said light fibers from said matrix to said receiving fiber sub-array.

**[0006]** Another patent document WO2005029028A1 discloses an optical tactile sensor. Said optical tactile sensor comprises a sensing part comprising a transparent elastic body and a plurality of marker groups provided in said body, each marker group being comprised of a number of colored markers, with markers constituting different marker groups having different colors for each group, said elastic body having an arbitrary curved surface; a photographing device for taking an image of behavior of colored markers when said curved surface of elastic body is contacted by an object to obtain image information of markers, and a force vector distribution reconstructing device including a transfer function by which a force vector applied to the surface is reconstructed from information as to the behavior of markers that is obtained from the image information of markers, and said force vector distribution reconstructing device reconstructing forces applied to said surface from said information as to the behavior of markers by using the transfer function.

**[0007]** Further optical tactile sensors are described in academic publications such as: BUYUKSAHIN UTKU ET AL, "Multi point, high sensitive tactile sensing module for robots and devices", PROCEEDINGS OF IEEE SENSORS 2014, 2 November 2014 (2014-11-02), pages 366-369, DOI: 10.1109/ICSENS.2014.6985010; LANG P ED - CHERITI A ET AL, "Design and prototyping of a fiber optic tactile array", CANADIAN CONFERENCE ON ELECTRICAL AND COMPUTER ENGINEERING, 2008 (CCECE 2008), 4 May 2008 (2008-05-04), pages 373-376,

ISBN: 978-1-4244-1642-4; PETER KAMPMANN ET AL, "Integration of Fiber-Optic Sensor Arrays into a Multi-Modal Tactile Sensor Processing System for Robotic End-Effectors", SENSORS, vol. 14, no. 4, 16 April 2014 (2014-04-16), pages 6854-6876, DOI: 10.3390/s140406854.

**Brief Description of the Invention**

**[0008]** The sensing system according to the present invention which detects touch comprises at least an intermediate layer; at least a upper layer located on the intermediate layer; at least one light source located under the intermediate layer; at least one image sensor located under the intermediate layer; at least a first fiber optic bundle comprising a plurality of fiber optic cables positioned such that a tips of which is facing to the light source and other tips of which is facing to the said intermediate layer, and transmitting the light obtained from the light source to the upper layer located on the intermediate layer; at least a second fiber optic bundle comprising a plurality of fiber optic cables, a tips of which is paired with at least one pixel of the image sensor and other tips of which is positioned facing to the intermediate layer, and transmitting the image of the upper layer located on the intermediate layer to the image sensor; at least one control unit which analyzes the image captured by the image sensor using image processing techniques so as to calculate a force applied on the intermediate layer; and at least a data link for data communication between the image sensor and the control unit.

**[0009]** In the sensing system according to the present invention, the light beams received from the light source pass through the intermediate layer onto the upper layer via the first fiber optic bundle. An image of the upper layer is transmitted to the image sensor via the second fiber optic bundle. Here, when a force is applied through the upper layer onto the intermediate layer, an image frame of a form (pattern) change, a color change or a brightness change of the upper layer captured by the image sensor is analyzed by the control unit using image processing techniques so that the force applied through the upper layer onto the intermediate layer may be calculated.

**Object of the Invention**

**[0010]** An object of the present invention is to provide a sensing system suitable for use in robotic systems.

**[0011]** Another object of the present invention is to provide a sensing system capable of sensing touch.

**[0012]** Another object of the present invention is to provide a sensing system with reduced power consumption.

[0013] Another object of the present invention is to provide a sensing system wherein it is detected whether it is subjected to a certain force.

[0014] Another object of the present invention is to provide a sensing system wherein application point and area of the force applied is detected.

[0015] Another object of the present invention is to provide a sensing system wherein the pressure applied is detected.

[0016] Yet another object of the present invention is to provide a sensing system capable of detecting the forces applied in vertical direction to the sensor as well as the combined forces.

**Description of the Drawings**

[0017] Illustrative embodiments of the sensing system according to the present invention are illustrated in the enclosed drawings, in which:

Figure 1 is a side view of the sensing system.

Figure 2 is a perspective view of an exemplary embodiment of the sensing system.

Figure 3 is a perspective view of an exemplary embodiment of the sensing system as used.

Figure 4 is a side view of another exemplary embodiment of the sensing system.

Figure 5 is a side view of another exemplary embodiment of the sensing system as used.

Figure 6 is a side view of another exemplary embodiment of the sensing system.

[0018] All the parts illustrated in the drawings are individually assigned a reference numeral and the corresponding terms of these numbers are listed as follows:

Sensing system	(S)
Intermediate layer	(1)
Light source	(2)
Image sensor	(3)
Upper layer	(4)
First fiber optic bundle	(5a)
Second fiber optic bundle	(5b)
Data link	(6)
Pattern	(7)
Outer layer	(8)

Elastic element	(9)
Obstacle	(10)
Distance element	(11)

### **Description of the Invention**

**[0019]** With the advanced robot technology, senses such as seeing, hearing, touching can be detected by sensor systems. Particularly, in exploration robots used to explore those areas that are dangerous for humans or not possible for humankind to arrive, the characteristics of the areas that are being explored can be detected accurately by means of the said sensor systems. Therefore, with the present invention, there is provided a sensing system capable of sensing touch.

**[0020]** The sensing system (S) according to the present invention, as illustrated in figures 1-6, comprises at least an intermediate layer (1); at least a upper layer (4) located on the intermediate layer (1); at least one light source (2) located under the intermediate layer (1) (distant to the upper layer (4)); at least one image sensor (3) (i.e. a CCD, CMOS sensor etc.) located under the intermediate layer (1) (distant to the upper layer (4)); at least a first fiber optic bundle (5a) comprising a plurality of fiber optic cables positioned such that a tips of which is facing to the light source (2) and other tips of which is facing to the said intermediate layer (1), and transmitting the light obtained from the light source (2) to the upper layer (4) located on the intermediate layer (1); at least a second fiber optic bundle (5b) comprising a plurality of fiber optic cables, a tips of which is paired with at least one pixel of the image sensor (3) and other tips of which is positioned facing to the said intermediate layer (1), and transmitting the image of the upper layer (4) located on the intermediate layer (1) to the image sensor (3); at least one control unit (not shown) which analyzes the image captured by the image sensor (3) using image processing techniques so as to calculate a force applied on the intermediate layer (1); and at least a data link (6) for data communication between the image sensor (3) and the control unit. Said data link (6) may be a wired connection or a wireless connection.

**[0021]** In a preferred embodiment of the invention, said upper layer (4) comprises at least a pattern (7), as shown in figures 2 and 3. The pattern (7) preferably having a squared, chess board shape deforms towards the intermediate layer (1), when exposed to a force, as shown in figure 3. An image frame of the upper layer (4) captured by the image sensor (3) is processed in the said control unit in order to determine in which area the pattern (7) has deformed and to what extent and how, and accordingly the force and pressure applied on the intermediate layer (1) is calculated.

**[0022]** According to the invention, said upper layer (4) comprises a material that changes color with force. In an illustrative embodiment, the upper layer (4) comprises a polarized film. If a force is applied on the polarized film, color changes are observed in the film based on the

intensity of the force applied. Since the image frame of the upper layer (4) captured by the image sensor (3) is analyzed by the control unit using image processing techniques, the extent of color change in the polarized film is detected. As the said color change and area of color change is associated with the force applied on the upper layer (4), the extent of force and pressure applied through the upper layer (4) onto the intermediate layer (1) is also calculated.

**[0023]** In another preferred embodiment of the invention, the upper layer (4) comprises a piezochromic material. Piezochromic materials change color with pressure. Said color change varies depending on the pressure applied. In this embodiment, since the image frame of the upper layer (4) captured by the image sensor (3) is analyzed by the control unit using image processing techniques, color change in the piezochromic material, area of color change and thus the extent of the force and pressure applied through the upper layer (4) onto the intermediate layer (1) are calculated. Piezochromic materials may be reversible (which returns to its original color when the force applied thereon is removed) or irreversible (which does not return its original color when the force applied thereon is removed). In a preferred embodiment of the invention, the piezochromic material used in the sensing system (S) is reversible. Thus, when the force applied on the intermediate layer (1) is removed, piezochromic material returns to its original color and when a different force is applied on the intermediate layer (1), the newly-applied force is also detected. In an alternative embodiment, said upper layer (4) comprises a first layer positioned at its side close to the surrounding environment and preferably containing a reversible piezochromic material (or any one of other types of top surfaces), and a second layer positioned at its side distant to the surrounding environment and containing irreversible piezochromic material. In this embodiment, when a force is externally applied on the intermediate layer (1), a force and pressure is applied on the second layer as well. However, when a force higher than the envisaged force is applied on the intermediate layer (1), a force higher than the threshold value is imposed on the second layer and the color of the second layer permanently changes due to the irreversible piezochromic material thereof. Thus, it is detected whether a force higher than the envisaged force is applied on the intermediate layer (1) or not, as well as the magnitude of the force applied based on the color change of the second layer.

**[0024]** In another preferred embodiment of the invention, the upper layer (4) comprises at least an outer layer (8) which is elastic and light-proof, at least an elastic element (9) positioned under the outer layer (8) and which is transparent and preferably in the form of a gel, and a plurality of (for example, at least in two rows) obstacles (10) positioned in the elastic element (9) and which are in the form of a light-proof particle such that its color is different from the outer layer (8), as shown in figures 4 and 5. As shown in figure 5, when a force is applied through the upper layer (4) onto the intermediate layer (1), said outer layer (8) pushes the obstacles (10) to right and left sides and approaches to the intermediate layer (1). As a result of this movement, color changes are seen in the image frame of the upper layer (4) captured by the image sensor (3). By analyzing the said image frame by the control unit using image processing techniques, the extent of the color change is determined. Thus, the amount of force applied through the upper layer (4) onto the intermediate layer (1) is calculated.

**[0025]** In another preferred embodiment of the invention, the said upper layer (4) comprises a phosphor and/or any other material that stores a part of the light in itself but proceeds to emit light when the light coming from the light source is cut off. In this embodiment, the said light source (2) is activated at certain intervals in order to increase energy of the phosphor and/or similar material. Thus, even if the light source (2) is switched off, phosphor and/or similar material emits light for a certain period of time. In this embodiment, when a force is applied through the upper layer (4) onto the intermediate layer (1), the brightness of a section of the image frame of the upper layer (4) captured by the image sensor (3) which is subjected to force is higher than those sections which are not subjected to force. In the said image frame, brightness of different pixels is compared so that the force applied through the upper layer (4) on the intermediate layer (1) may be calculated.

**[0026]** In an alternative embodiment of the invention, said upper layer (4) partially transmits light (for example, a mirror film or a fine porous structure like a veil). As known, such structures normally transmit light but if an opaque object blocking transmission of light is placed behind same, it reflects light back. In this embodiment, light beams received from the light source (2), which are transmitted through the intermediate layer (1) onto the upper layer (4) via the first fiber optic bundle (5a), are normally transmitted to the surrounding environment (and an image of the surrounding environment is present in the image captured by the image sensor (3)). However, if an object is placed on the intermediate layer (1), light beams pass through the upper layer (4) and impinge onto the object and are reflected back from the object. An image of the said object is also present in the image frame captured by the image sensor (3). The image frame captured by the image sensor (3) is analyzed by the control unit using image processing techniques so that the force applied through the upper layer (4) onto the intermediate layer (1) may be calculated.

**[0027]** In another alternative embodiment of the invention, the first fiber optic bundle (5a), and/or the second fiber optic bundle (5b) are multi-piece bundles. In this embodiment, the first fiber optic bundle (5a) and/or the second fiber optic bundle (5b) comprises a first section including a plurality of fiber optic cables; a second section including a plurality of fiber optic cables; and a carrier fiber optic cable, to end of which is connected a tip of each fiber optic cables in the said first section and to another end of which is connected a tip of each fiber optic cable in the said second section, whose diameter is larger than that of the fiber optic cables in the first section and the second section, and which transmits the lights carried by the fiber optic cables in the first section to the fiber optic cables in the second section and the lights carried by the fiber optic cables in the second section to the fiber optic cables in the first section. In this way, in the embodiments wherein the length of the fiber optic cables must be long, it will be sufficient that one or a limited number of fiber optic cables (carrier fiber) is long, instead of a high number of fiber optic cables. In another embodiment of the carrier fiber, the diameter of the said carrier fiber optic cable is lower than that of the first section and the second section. In this embodiment, in order to have an exact pairing of each fiber optic cable in the first section with each fiber optic cable in the second section (i.e. to ensure that the light beams coming from different fiber optic cables do not intervene with each other), the first optic bundle (5a) and/or the second fiber optic bundle (5b) also comprise at least two optic elements, each

interposed between the carrier fiber optic cable and the first section, and between the carrier fiber optic cable and the second section. The said optic elements prevent the light beams flowing through the carrier fiber optic cable from intervening with each other.

**[0028]** In an alternative embodiment of the invention shown in figure 6, the sensing system comprises at least two distance elements (11), positioned between the said upper layer (4) and the intermediate layer (1), and which maintain the upper layer (4) and the intermediate layer (1) spaced from each other. In this embodiment, said upper layer (4) may either be elastic, or may be rigid.

**[0029]** In the sensing system (S) according to the present invention, light beams received from the light source (2) are passed through the intermediate layer (1) and onto the upper layer (4) via the first fiber optic bundle (5a). An image of the upper layer (4) is transmitted to the image sensor by means of the second fiber optic bundle (5b). Here, when a force is applied through the upper layer (4) onto the intermediate layer (1), an image frame of the form (and/or pattern (7)) change, color change or brightness change of the top surface (4) captured by the image sensor (3) is analyzed by the control unit using image processing techniques, so that the force applied through the upper layer (4) onto the intermediate layer (1) may be calculated. Furthermore, thanks to the displacement area represented by the area of color change in the image obtained, the pressure applied in any direction (for example, transversal angles) is calculated. Furthermore, with the detection of a change in a pattern (7) of the upper layer (4), the forces applied on the upper layer (4) from different angles (e.g. right angles) as well as their direction may also be detected.

## **REFERENCES CITED IN THE DESCRIPTION**

### Cited references

This list of references cited by the applicant is for the reader's convenience only. It does not form part of the European patent document. Even though great care has been taken in compiling the references, errors or omissions cannot be excluded and the EPO disclaims all liability in this regard.

### **Patent documents cited in the description**

- [US2010155579A1 \[0003\]](#)
- [WO2014011126A1 \[0004\] \[0004\]](#)
- [US4547668A \[0005\]](#)

- WO2005029028A1 [0006]

**Non-patent literature cited in the description**

- **BUYUKSAHIN UTKU et al.** Multi point, high sensitive tactile sensing module for robots and devices PROCEEDINGS OF IEEE SENSORS 2014, 2014, 366-369 [0007]
- **LANG P ED - CHERITI A et al.** Design and prototyping of a fiber optic tactile array CANADIAN CONFERENCE ON ELECTRICAL AND COMPUTER ENGINEERING, 2008 (CCECE 2008), 2008, 978-1-4244-1642-4373-376 [0007]
- **PETER KAMPMANN et al.** Integration of Fiber-Optic Sensor Arrays into a Multi-Modal Tactile Sensor Processing System for Robotic End-Effectors SENSORS, 2014, vol. 14, 46854-6876 [0007]

## ET BERØRINGS- OG TRYKFØLESYSTEM MED FORSKELLIGE ØVRE LAG

## PATENTKRAV

1. Et følesystemfølesystem (S), der registrerer berøring, som omfatter:
  - mindst et mellemlag (1);
  - 5 - mindst et øverste lag (4), der er placeret på mellemlaget (1);
  - mindst en lyskilde (2) placeret under mellemlaget (1);
  - mindst en billedsensor (3) placeret under mellemlaget (1);
  - mindst et første bundt af optiske fibre (5a), der omfatter en flerhed af optiske fiberkabler, der er placeret således, at en af dets spidser vender mod  
10 lyskilden (2) og andre af dets spidser vender mod det nævnte mellemlag (1), og som transmitterer det lys, der opnås fra lyskilden (2), til det øverste lag (4), der er placeret på mellemlaget (1);
  - mindst et andet bundt af optiske fibre (5b), der omfatter en flerhed af optiske fiberkabler, hvoraf en af dets spidser er parret med mindst én pixel i billedsensoren  
15 (3) og andre af dets spidser er placeret over for mellemlaget (1), og som overfører billedet af det øverste lag (4), der er placeret på mellemlaget (1), til billedsensoren (3);
  - mindst en styreenhed, der analyserer det billede, som er optaget af billedsensoren (3), ved hjælp af billedbehandlingsteknikker til beregning af en kraft, der påføres mellemlaget (1), og  
20 - mindst en dataforbindelse (6) til datakommunikation mellem billedsensoren (3) og styreenheden

**kendetegnet ved, at** det nævnte øverste lag (4) omfatter en polariseret film eller et piezokromt materiale som materiale, der skifter farve ved tryk.

2. Et følesystem (S) i henhold til krav 1, **kendetegnet ved, at** det nævnte  
25 øverste lag (4) omfatter mindst et mønster (7).

3. Et følesystem (S) i henhold til krav 2, **kendetegnet ved, at** det nævnte mønster (7) har form af et skakbræt.
4. Et følesystem (S) i henhold til krav 1, **kendetegnet ved, at** det nævnte piezokromiske materiale er reversibelt.
- 5 5. Et sensorisk system (S) i henhold til krav 1, **kendetegnet ved, at** det nævnte øverste lag (4) omfatter et første lag, der er placeret på dets side tæt på det omgivende miljø, og et andet lag, der er placeret på dets side fjernt fra det omgivende miljø, og som indeholder et irreversibelt piezokromt materiale.
6. Et følesystem (S) i henhold til krav 5, **kendetegnet ved, at** det nævnte  
10 første lag omfatter et reversibelt piezokromt materiale.
7. Et følesystem (S) i henhold til krav 1, **kendetegnet ved, at** det øverste lag (4) omfatter mindst et ydre lag (8); mindst et elastisk element (9) placeret under det ydre lag (8); og en flerhed af hindringer (10) placeret i det elastiske element (9), og som er i form af en lysbestandig partikel, således at dens farve er  
15 forskellig fra det ydre lag (8).
8. Et følesystem (S) i henhold til krav 7, **kendetegnet ved, at** det elastiske element (9) er i form af en gel.

# DRAWINGS

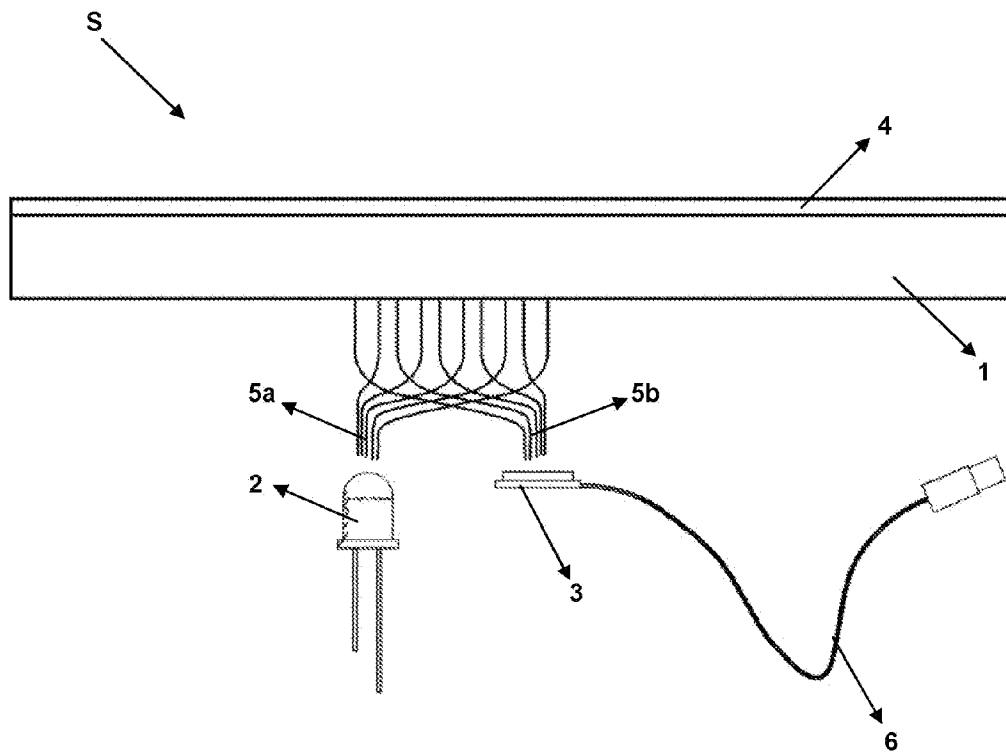

Figure - 1

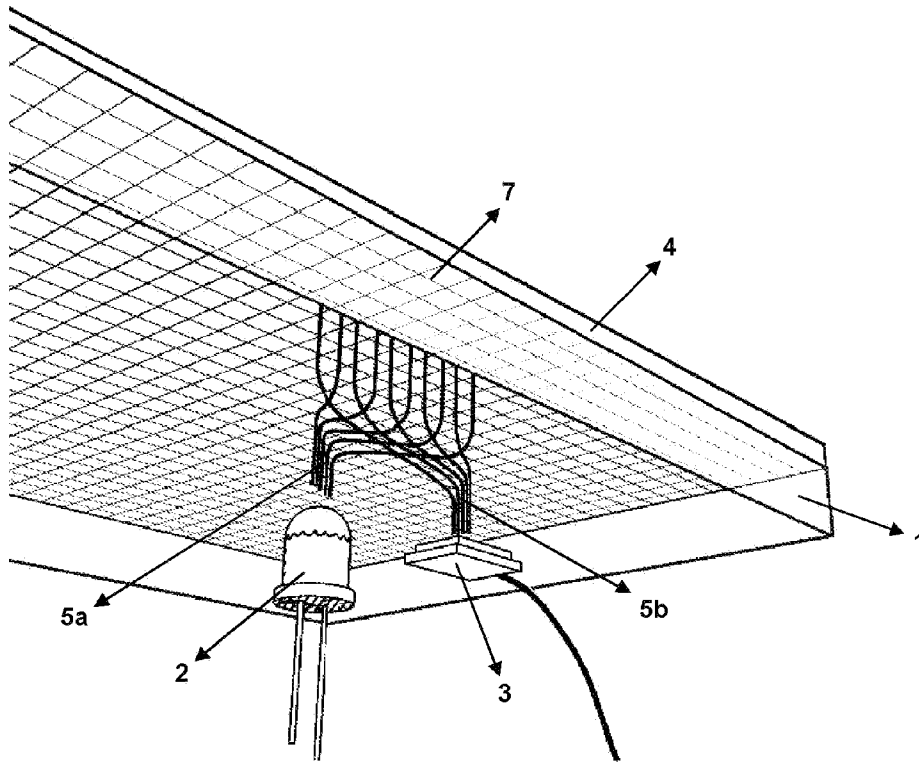

Figure - 2

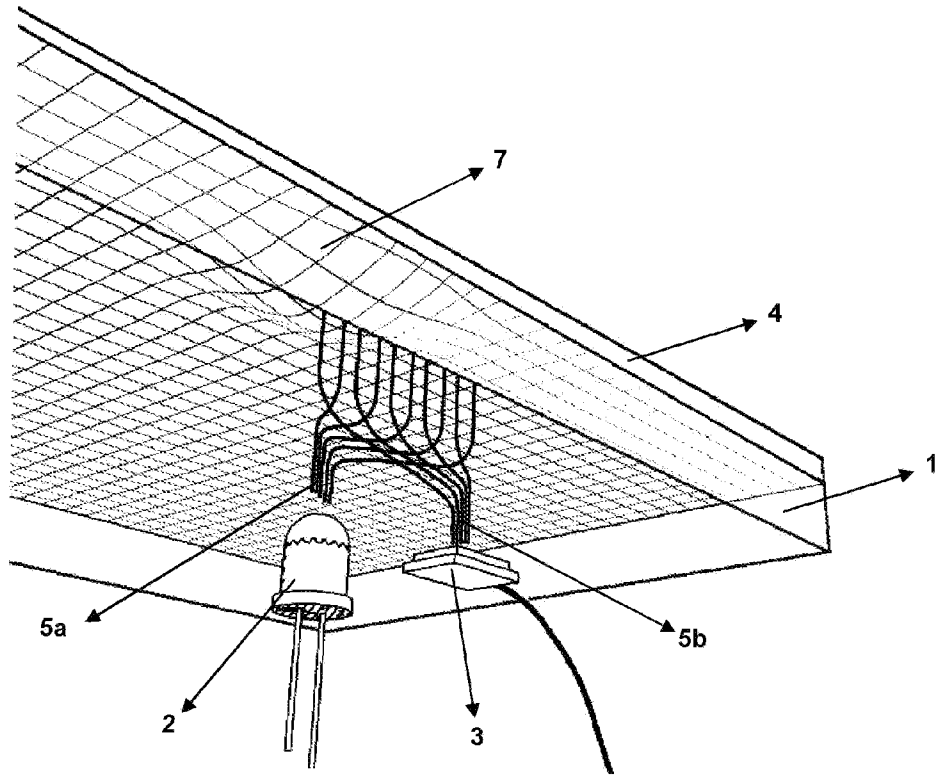

Figure - 3

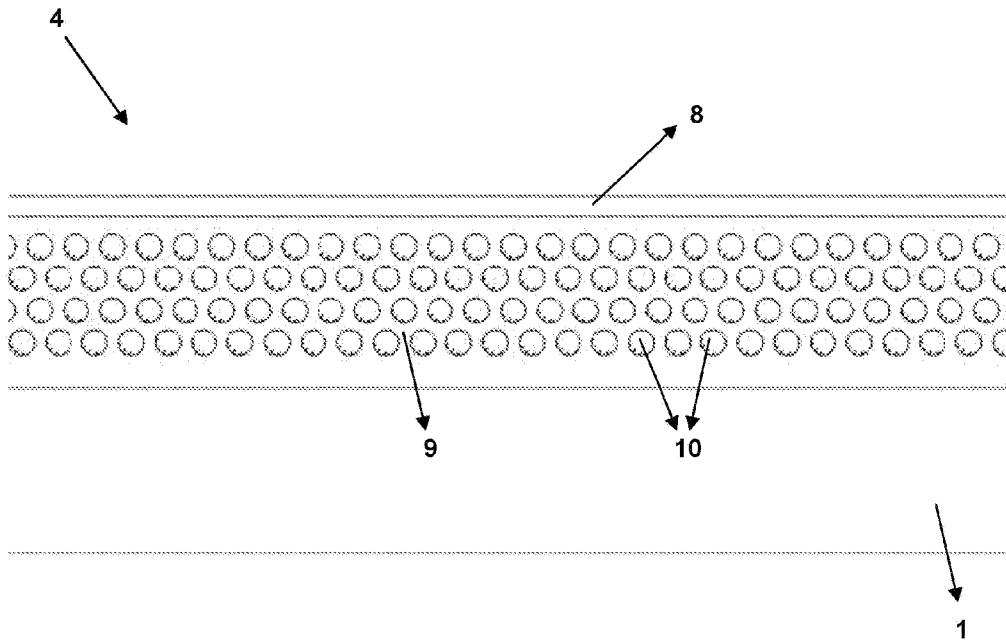

Figure - 4

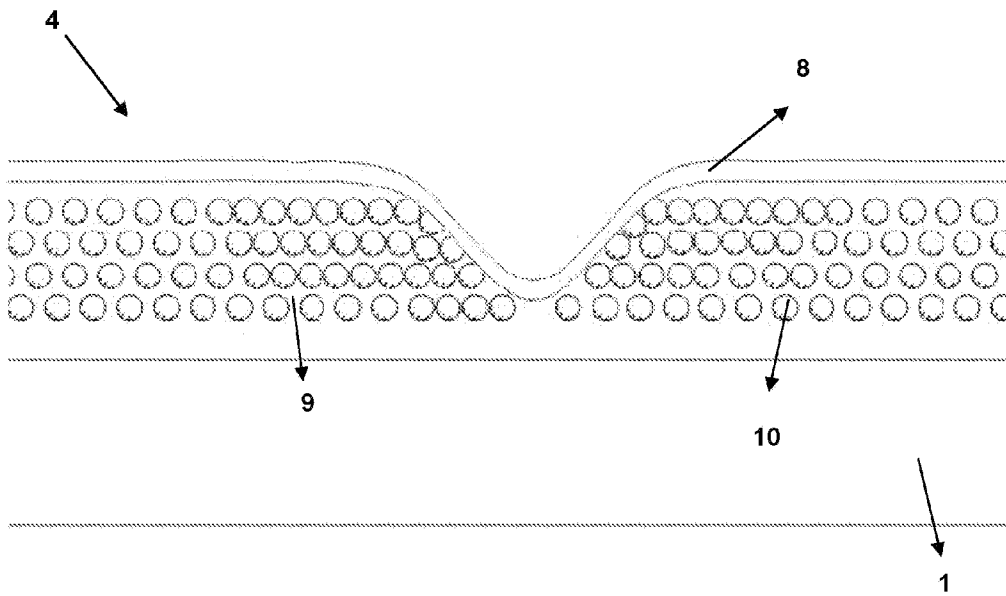

Figure - 5

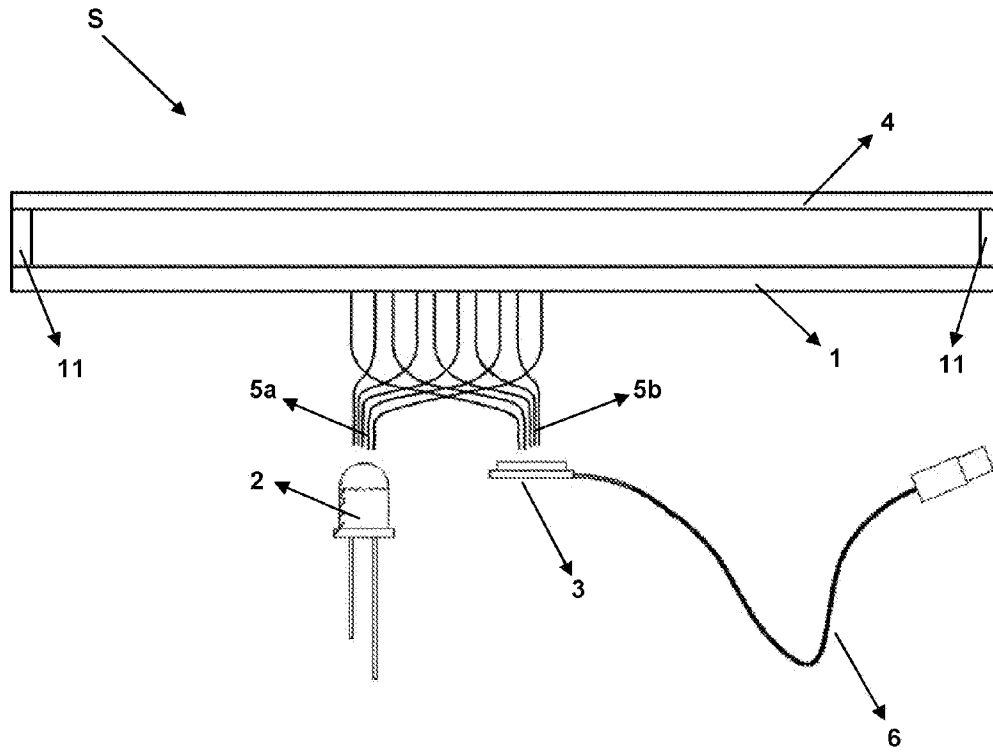

Figure - 6