



(12) **United States Design Patent**  
**Ashman-Stauss et al.**

(10) **Patent No.:** **US D799,033 S**  
(45) **Date of Patent:** **\*\* \*Oct. 3, 2017**

(54) **CATHETER HANDLE**  
(71) Applicant: **W. L. Gore & Associates, Inc.**,  
Newark, DE (US)  
(72) Inventors: **Jennifer Ashman-Stauss**, Cincinnati,  
OH (US); **Mark Bates**, Westwood, MA  
(US); **Daniel S. Cole**, Flagstaff, AZ  
(US); **Nathan L. Friedman**, Flagstaff,  
AZ (US); **Justin W. Sokel**, Flagstaff,  
AZ (US); **Damien Vizcarra**, Pasadena,  
CA (US)

D328,788 S \* 8/1992 Sagae ..... D24/129  
5,181,508 A \* 1/1993 Poole, Jr. .... A61M 16/0463  
128/203.12  
5,207,648 A 5/1993 Gross  
5,250,038 A 10/1993 Melker et al.  
D351,227 S 10/1994 Patton et al.  
D353,197 S \* 12/1994 Hawks ..... D24/112  
5,437,626 A 8/1995 Cohen et al.  
D383,538 S 9/1997 Erskine et al.  
5,846,221 A 12/1998 Snoke et al.  
D407,488 S 3/1999 Injev  
6,203,507 B1 3/2001 Wadsworth et al.  
D440,310 S \* 4/2001 Laks ..... D24/112

(Continued)

(73) Assignee: **W. L. Gore & Associates, Inc.**,  
Newark, DE (US)  
(\* ) Notice: This patent is subject to a terminal dis-  
claimer.  
(\*\*) Term: **14 Years**  
(21) Appl. No.: **29/522,820**

**FOREIGN PATENT DOCUMENTS**

WO 2014026028 A1 2/2014

**OTHER PUBLICATIONS**

Absolute Pro Vascular Self-Expanding Stent System, Product Bro-  
chure: Abbot Vascular USA, 2006, Abbott Laboratories, copyright  
2006-20.

(Continued)

*Primary Examiner* — David Muller

(22) Filed: **Apr. 2, 2015**  
(51) **LOC (10) Cl.** ..... **24-02**  
(52) **U.S. Cl.**  
USPC ..... **D24/130**  
(58) **Field of Classification Search**  
USPC ..... D24/127-131, 112-114, 133, 186;  
606/181, 185; 604/264, 523-528, 272,  
604/187, 158, 164.01-164.11, 181, 184,  
604/227; 600/101, 139, 143;  
128/200.24, 207.14, 207.15  
CPC ..... A61M 25/00; A61M 39/00; A61M 27/00;  
A61M 25/0043; A61M 25/0067; A61M  
25/0097  
See application file for complete search history.

(57) **CLAIM**

An ornamental design for a catheter handle, as shown and  
described.

**DESCRIPTION**

FIG. 1 is a three-quarter front isometric view of a catheter  
handle.  
FIG. 2 is a three-quarter rear isometric view thereof.  
FIG. 3 is a top plan view thereof.  
FIG. 4 is a bottom plan view thereof.  
FIG. 5 is a left side view thereof.  
FIG. 6 is a right side view thereof.  
FIG. 7 is a rear view thereof; and,  
FIG. 8 is a front view thereof.

(56) **References Cited**  
**U.S. PATENT DOCUMENTS**

D323,889 S \* 2/1992 Wyatt ..... D24/129  
D327,320 S 6/1992 Bryant

**1 Claim, 7 Drawing Sheets**

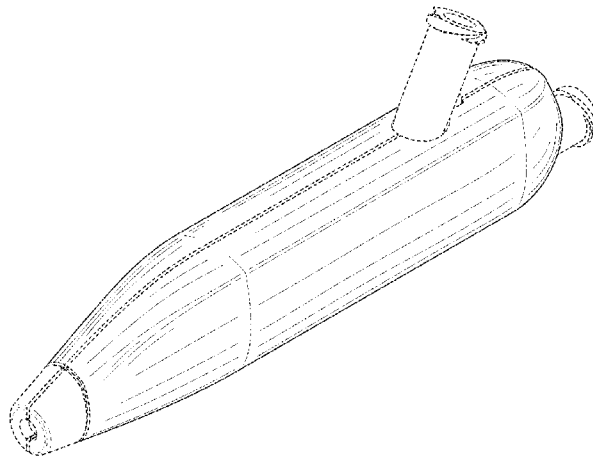

(56)

References Cited

U.S. PATENT DOCUMENTS

6,217,564 B1 4/2001 Peters et al.  
 6,267,754 B1 7/2001 Peters  
 D449,104 S \* 10/2001 Baker ..... D24/112  
 6,508,789 B1 1/2003 Sinnott et al.  
 6,508,807 B1 1/2003 Peters  
 6,599,265 B2 7/2003 Bon  
 6,605,075 B1 8/2003 Burdulis  
 D482,447 S \* 11/2003 Harding ..... D24/129  
 D506,828 S \* 6/2005 Layne ..... D24/129  
 D518,175 S 3/2006 Hardin, Jr. et al.  
 7,413,543 B2 8/2008 Ohno et al.  
 7,497,853 B2 3/2009 Fischer et al.  
 7,566,316 B2 7/2009 McGuckin et al.  
 D606,190 S 12/2009 Pruitt et al.  
 7,637,932 B2 12/2009 Bolduc et al.  
 7,731,708 B2 6/2010 Haarala et al.  
 D634,007 S \* 3/2011 Zinger ..... D24/129  
 D648,851 S 11/2011 Copeland et al.  
 D654,583 S 2/2012 Lee-Sepsick  
 D661,388 S 6/2012 Clark  
 D663,832 S 7/2012 Essinger et al.  
 D704,336 S \* 5/2014 Chon ..... D24/133  
 D715,921 S \* 10/2014 Wan ..... D24/112  
 D720,850 S \* 1/2015 Hsia ..... D24/130  
 D748,245 S \* 1/2016 Petersen ..... D24/113  
 2003/0149422 A1 8/2003 Muller  
 2004/0097903 A1 5/2004 Raulerson  
 2004/0133185 A1 7/2004 Nash et al.  
 2005/0070878 A1 3/2005 Triplett et al.  
 2005/0209582 A1 9/2005 Quinn et al.  
 2008/0200901 A1 8/2008 Rasmussen et al.  
 2008/0319420 A1 12/2008 Rosenman et al.  
 2009/0234328 A1 9/2009 Cox et al.  
 2009/0287188 A1 11/2009 Golden et al.  
 2010/0016838 A1 1/2010 Butts et al.  
 2010/0100074 A1 4/2010 Smith et al.  
 2010/0274227 A1 10/2010 Khairkahan et al.  
 2010/0331823 A1 12/2010 Blanchard  
 2011/0238147 A1 9/2011 Bennett et al.  
 2013/0204206 A1 8/2013 Morgan et al.

2013/0253469 A1 9/2013 Freed  
 2013/0304036 A1 11/2013 Kimmel et al.  
 2014/0180257 A1 6/2014 Zinn

OTHER PUBLICATIONS

Amphirion Deep Infrapopliteal OTW+RX PTA Balloon Catheter 0.014", Product Brochure, Medtronic.  
 Biotronik's New Length Pulsar-18 Peripheral Arterial Stent Now Available. News Release, <http://medicalbuy.net/2012/11/biotroniks-lengthy-pulsar-18-peripheral-arterial-stent/>.  
 Complete SE Vascular Self-Expanding Stent Product Details, Medtronic, Peripheral Therapies International for Healthcare Professionals. <http://www.peripheral.medtronicendovascu.com>.  
 Complete SE Vascular: Complete SE-Technical Specifications, Medtronic Peripheral Therapies International for Healthcare Professionals, <http://www.peripheral.medtronicendovascu.com>.  
 Cordis S.M.A.R.T.® Control™ Nitinol Stent System, Product Brochure, Cordis Europe, 2007, 4 pages.  
 E\*Luminexx® Biliary Stent: Instructions for Use. Bard, Peripheral Vascular B05691 Vers 6/11-09.  
 EverFlex™ Self-expanding Peripheral Stent with Entrust™ Delivery System, Product Brochure, (supradesup-selfexpanding-peripheral-stent-with-entrustsupradesup-delivery-system).  
 LifeStent Vascular Stent Systems, Product Brochure, Bard Peripheral Vascular, © Copyright 2011, C. R. Bard, Inc., 2 pages.  
 Misago®—Self-expanding peripheral stent, Product Brochure, Terumo International Systems, <http://www.terumo-europe.com/en-emea/peripheral-intervention/peripheral-stents>, 8 pg.  
 Sinus-Superflex-635 Self Expanding Nitinol Stent System, Product Brochure, Optimed, May 2014, 6 pages.  
 Supera Interwoven Self-Expanding Nitinol Stent Transhepatic Biliary System, Product Brochure, IDEV Technologies (<http://www.farmpd.com/medical-equipment-product-development/i>).  
 The Bard Luminexx Product Brochure, Vascular News—New Products (VN21) Bard (Europe), Mar. 15, 2004, 1 page.  
 Tsunami® Peripheral—Balloon-expandable stent, Product Brochure, Terumo International Systems, <http://www.terumo-europe.com/en-emea/peripheral-intervention/peripheral-stents>.

\* cited by examiner

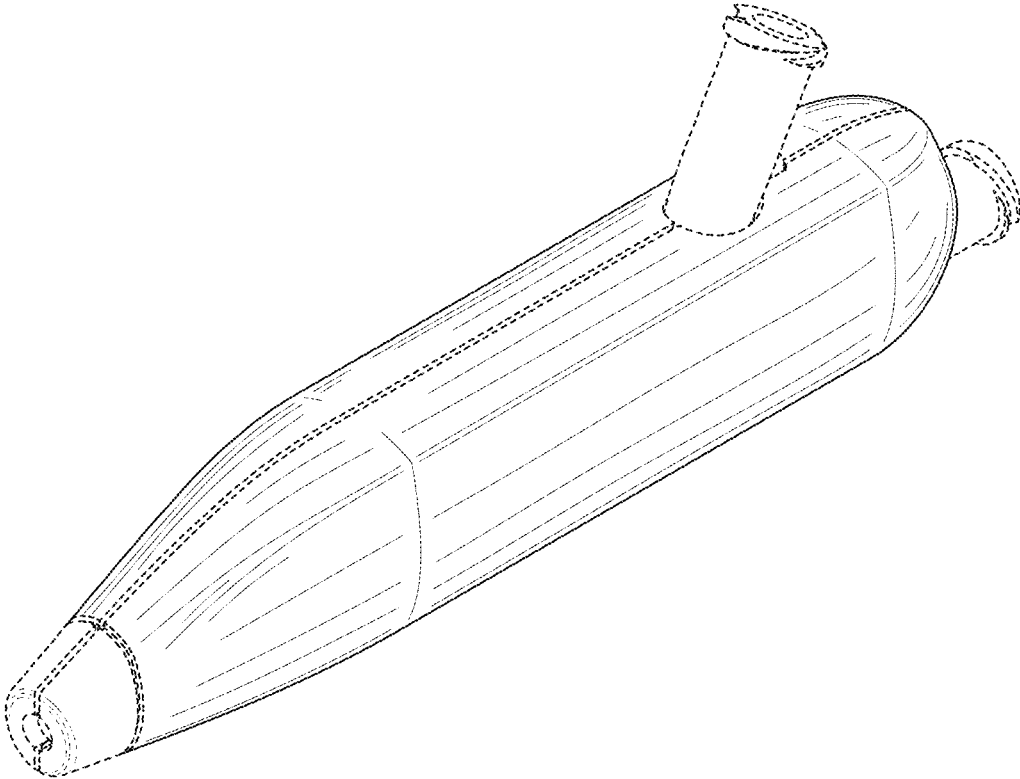

FIG. 1

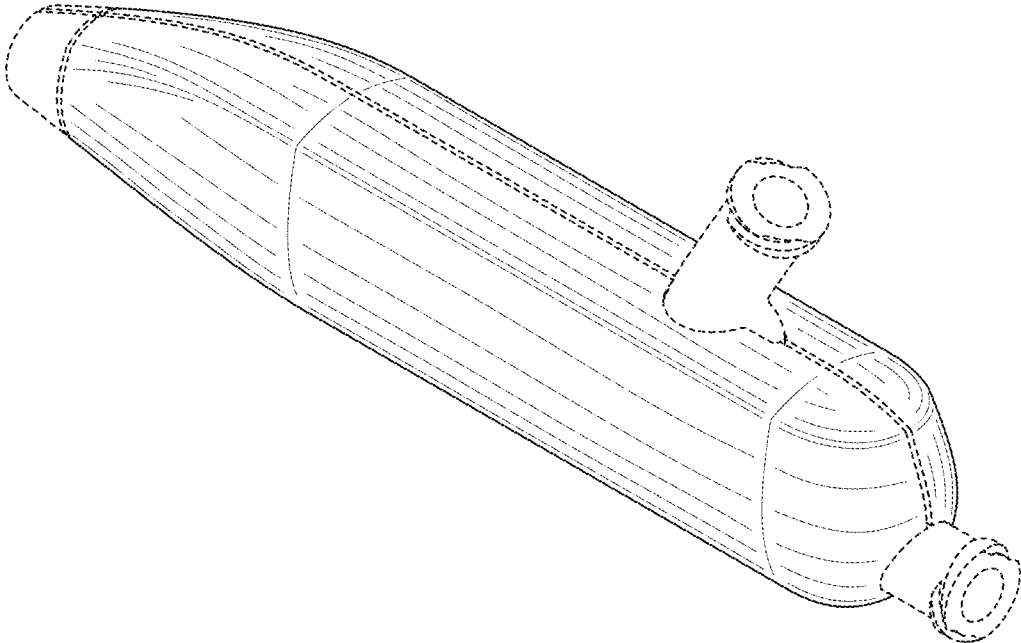

FIG. 2

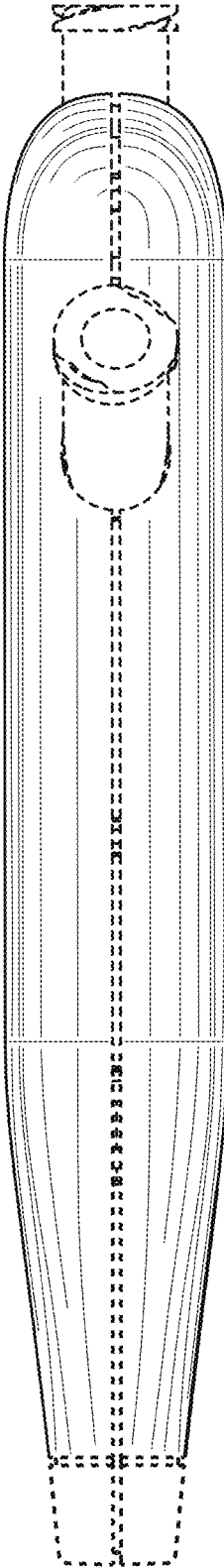

FIG. 3

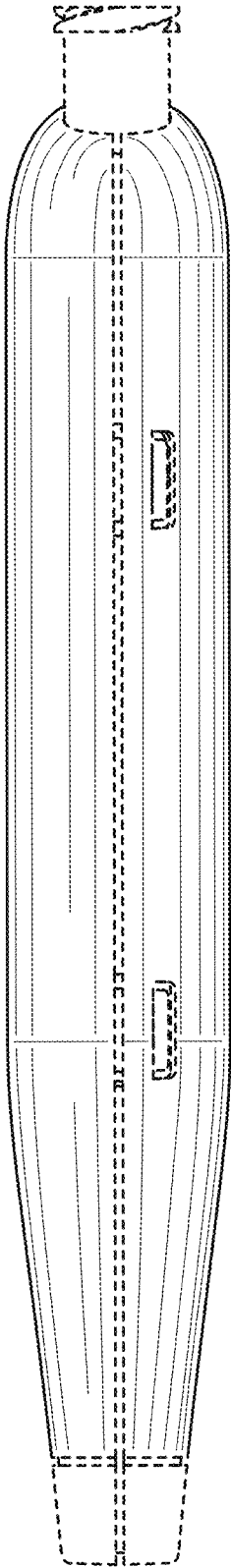

FIG. 4

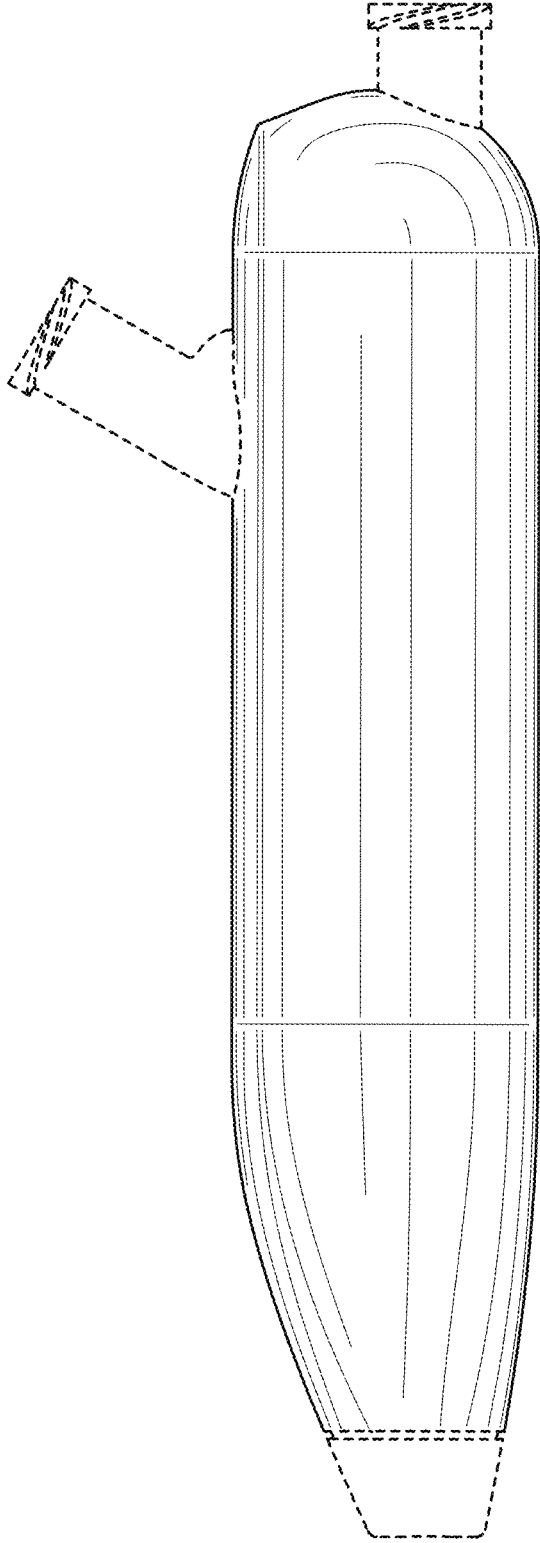

FIG. 5

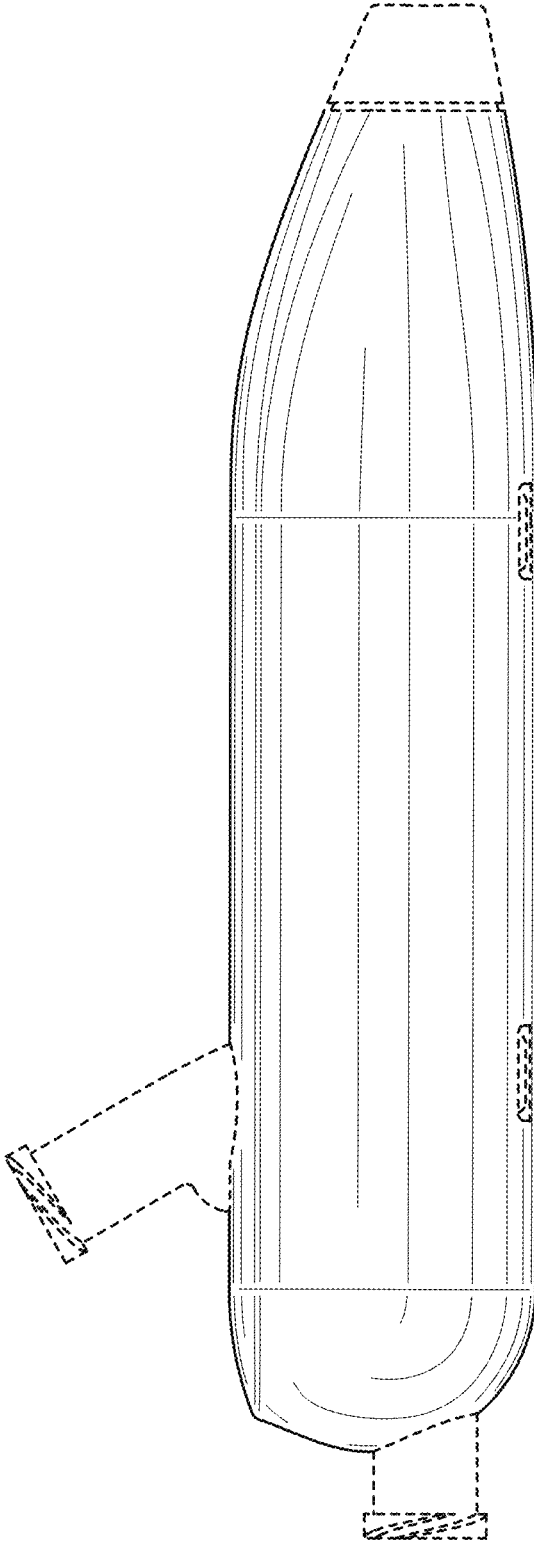

FIG. 6

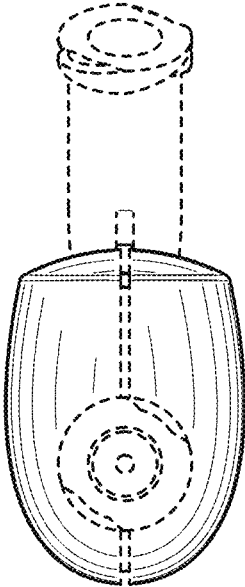

FIG. 7

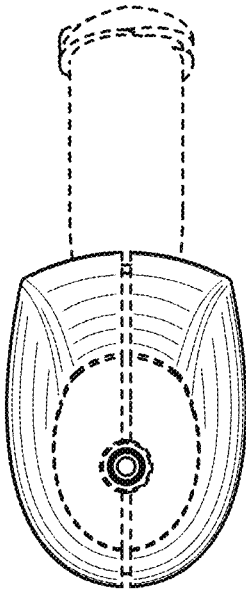

FIG. 8