

J. E. KEA.

Self-Operating Switches.

No. 134,478.

Patented Dec. 31, 1872.

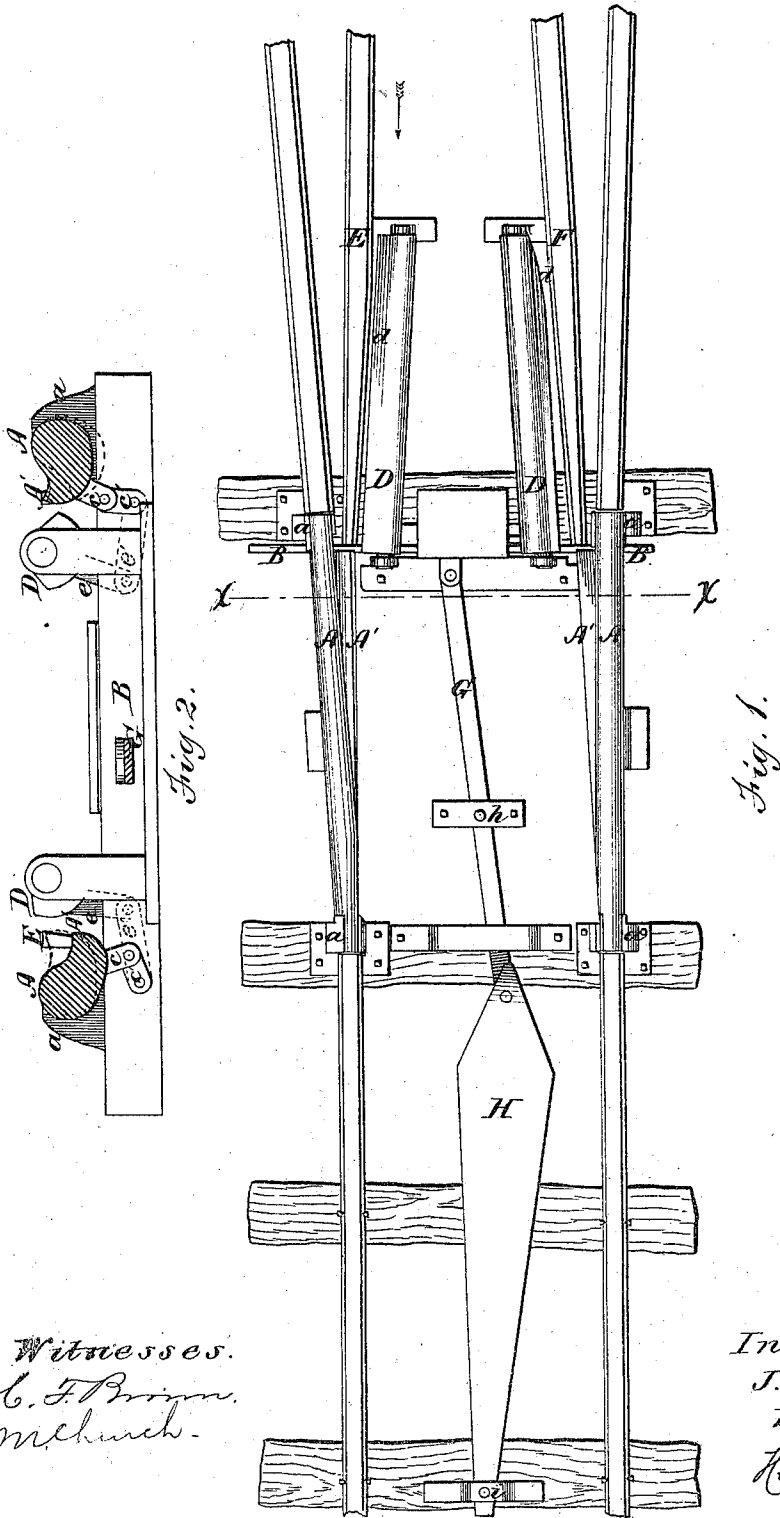

Witnesses.  
C. F. Brown.  
Mechanic.

Inventor.  
J. E. Kea.  
by his Attys.  
Hill & Ellsworth.

# UNITED STATES PATENT OFFICE.

JAMES E. KEA, OF PHILADELPHIA, PENNSYLVANIA.

## IMPROVEMENT IN SELF-OPERATING SWITCHES.

Specification forming part of Letters Patent No. 134,478, dated December 31, 1872.

### *To all whom it may concern:*

Be it known that I, JAMES E. KEA, of the city and county of Philadelphia and State of Pennsylvania, have invented a new and Improved Automatic Railroad Switch; and I do hereby declare the following to be a full and exact description of the same, reference being had to the accompanying drawing forming part of this specification, in which—

Figure 1 is a plan view, and Fig. 2 is a transverse vertical section in the line *x x*.

Similar letters of reference in the accompanying drawing indicate the same parts.

This invention has for its object to improve the construction of rolling-rail switches, in respect of, first, the means for causing the wheels of the engine to roll the rails into the required position in advance of the train; second, the means for causing a guide on the engine to roll the rails into the required position in advance of the train; and, third, the means for automatically locking the rails when thus rolled into the required position. To this end the invention consists, first, in the combination of rotating guide-rails placed between the main rails and in position to be acted on by engine-wheels, with the rolling switch-rails, and intermediate means for communicating the motion of the guide-rails to the switch-rails; second, in the combination of a compound lever placed between the main rails and in position to be acted on by a guide on the engine, with the rolling switch-rails and intermediate means for operating the latter by the compound lever; third, in the combination of the rolling switch-rails with a reciprocating rod placed crosswise of and beneath them, and toggle-links connecting said rails with said bar; all of which I will now proceed to describe.

In the drawing, A are the switch-rails, having their ends placed in boxes *a*, which admit of the rolling of the rails and at the same time hold them securely in place. Each of the rails A has a supplementary rail, A', and each supplementary rail has an arm, *c*, extending downward from its larger end. B is the reciprocating rod placed beneath the rails A, held in position by any suitable means, and connected by links *c'* with the arm *c*. One of the rails A' forms part of the main track, and the other of

the side track, and the same is true of the rails A, so that each rail A is complementary to one of the rails A'. Hence it is necessary to the completion of either of the tracks shown in the drawing that the rail forming the supplement of the main switch-rail of that track should be turned down out of the way, and that the rail forming the complement of said main switch-rail should be turned up. Such turning is effected by moving the rod B either way, and this can be done by hand, if necessary. At the same time the arm *c* and link *c'* appertaining to that rail A' which is turned up come into the same line and into line with the strain of the passing train on the rail A', and therefore lock said rail securely against such strain. D are guide-rails mounted in boxes between the rails E F. Each rail D has a groove, *d*, in its upper surface on the side next the contiguous rail E or F, and at the end furthest from the rod B. Each rail D has also an arm, *e*, extending downward from its ungrooved end, which arms are connected by links *e'* with the rod B. The rails D should be so placed that one of the grooves *d* is up and the other down at the same time, and also so placed that the rail D having its groove turned down is next to the rail A' that is turned up, and vice versa. Hence when a train is approaching in the direction of the arrow, along the track that is complete, it does not strike either rail D, but when the train is approaching in the same direction along the incomplete track, the engine-wheel strikes the upturned groove *d* of one of the rails D and turns that rail down, and at the same time, through the medium of the arms *e e'*, rod B, and arms *c c'*, completes the track in advance of the train by raising the depressed rail A' and depressing the raised rail A'. Therefore this arrangement dispenses with the services of a switch-tender and guards against the train running off the track. On the other side of the rod B from the rails D, and between the main rails, is a compound lever G H, one end of the part G being pivoted to the rod B and the other end pivoted to the plate H, and the part G being pivoted at *h*. The other end of the raised plate H is jointed at *i*. This plate has inclined edges, and is intended to be used in combination

with a guide on the engine, which can be put down to either side of the plate H and made use of by the engineer to direct his train to either track, as he may desire, by rolling the rails A A' through the medium of the compound lever G H, rod B, and arms *c c'*.

What I claim as new is—

1. The combination of rolling switch-rails A, reciprocating rod B, and toggle-levers *c c'*, in the manner described, and for the purpose of locking the switch-rails.

2. The combination of switch-rails A, rod B, and levers *c c'* with rolling guide-rails D and

links *c c'*, in the manner described, and for the purpose of causing the wheels of the engine to roll the switch-rails.

3. The combination of switch-rails A, rod B, and levers *c c'* with the compound lever G H, in the manner described, and for the purpose of causing a guide on the engine to roll the switch-rails.

JAMES E. KEA.

Witnesses:

SAML. P. JONES, Jr.,  
M. F. JONES.