

(No Model.)

4 Sheets—Sheet 1.

A. FOUCHER.  
TYPE FOUNDRY MACHINE.

No. 526,569.

Patented Sept. 25, 1894.

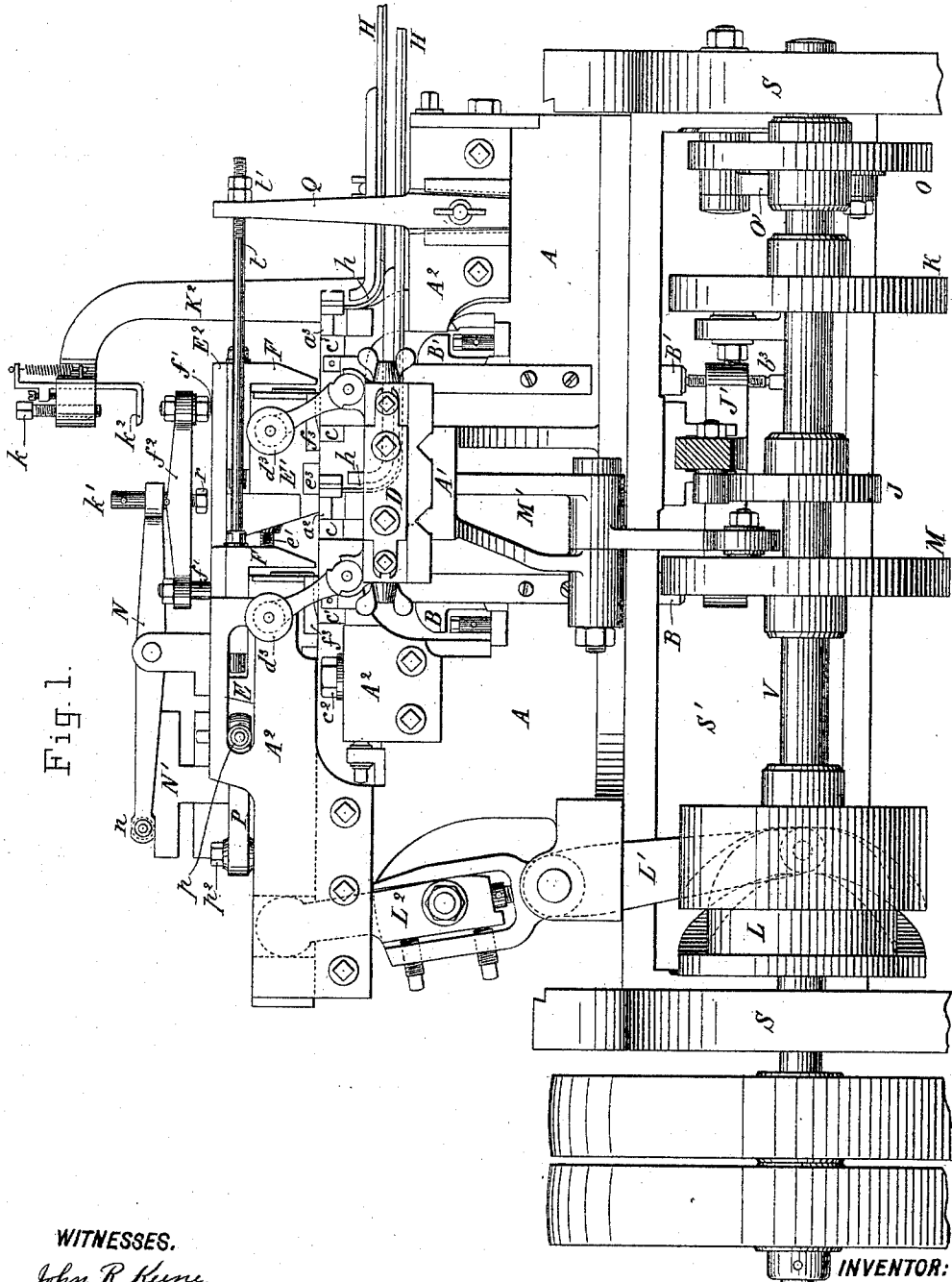

Fig. 1.

WITNESSES.

*John R. Keene.*

*John Locke*

INVENTOR:

*Auguste Foucher*

BY

*Munn & Co*

ATTORNEYS.



A. FOUCHER.  
TYPE FOUNDRY MACHINE.

No. 526,569.

Patented Sept. 25, 1894.

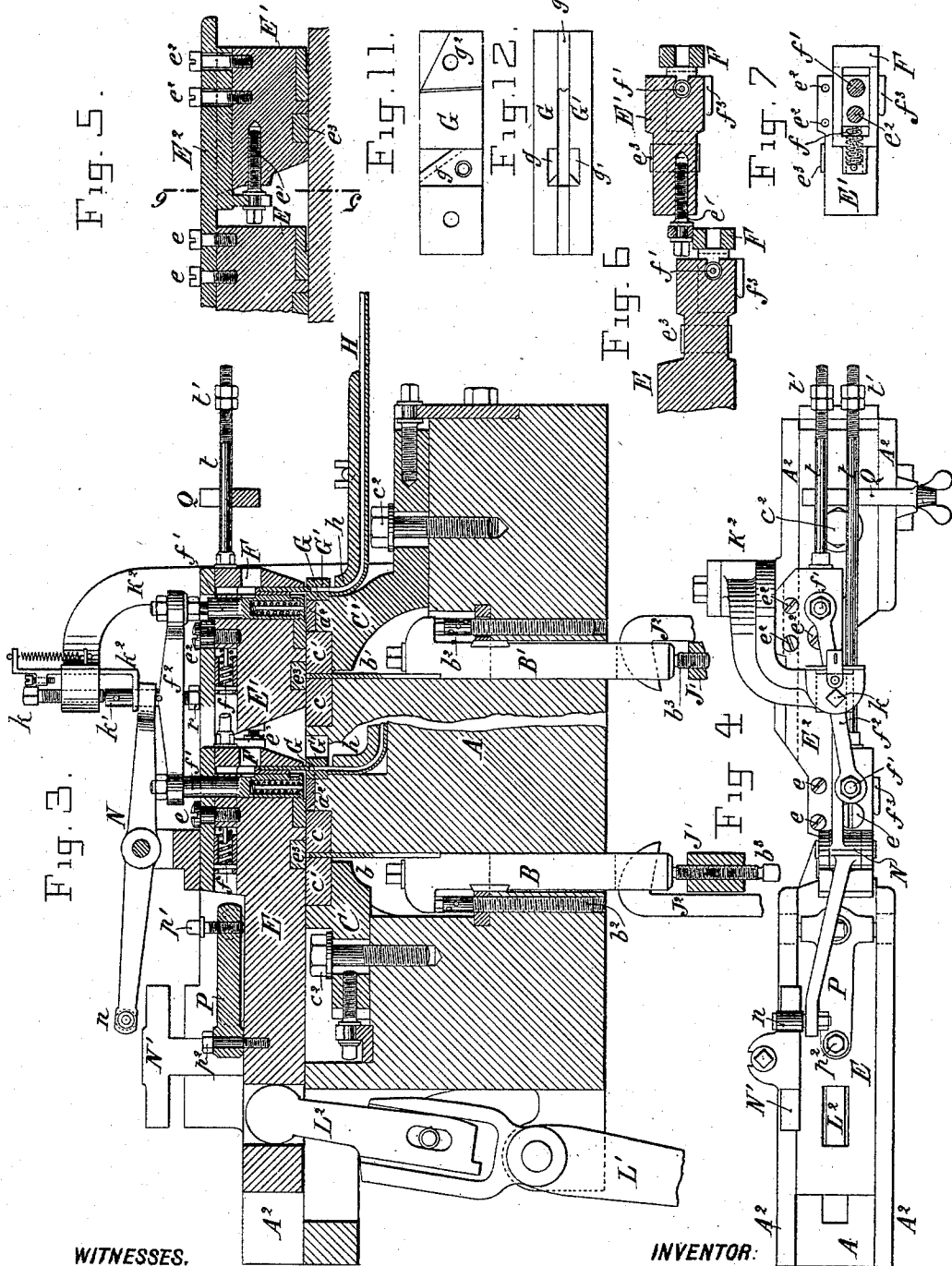

WITNESSES.

*John R. Keene*  
*John L. Latta*

INVENTOR:

*Auguste Foucher*  
*Munn & Co*

BY

ATTORNEYS.

A. FOUCHER.  
TYPE FOUNDRY MACHINE.

No. 526,569.

Patented Sept. 25, 1894.

Fig. 10.

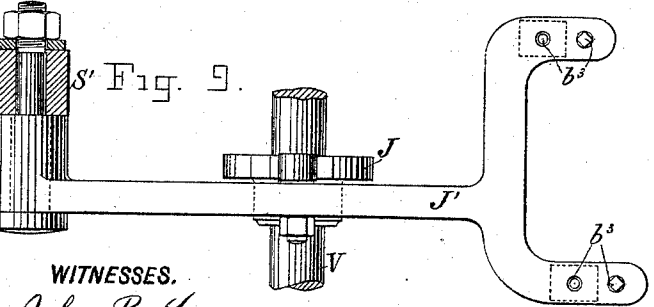
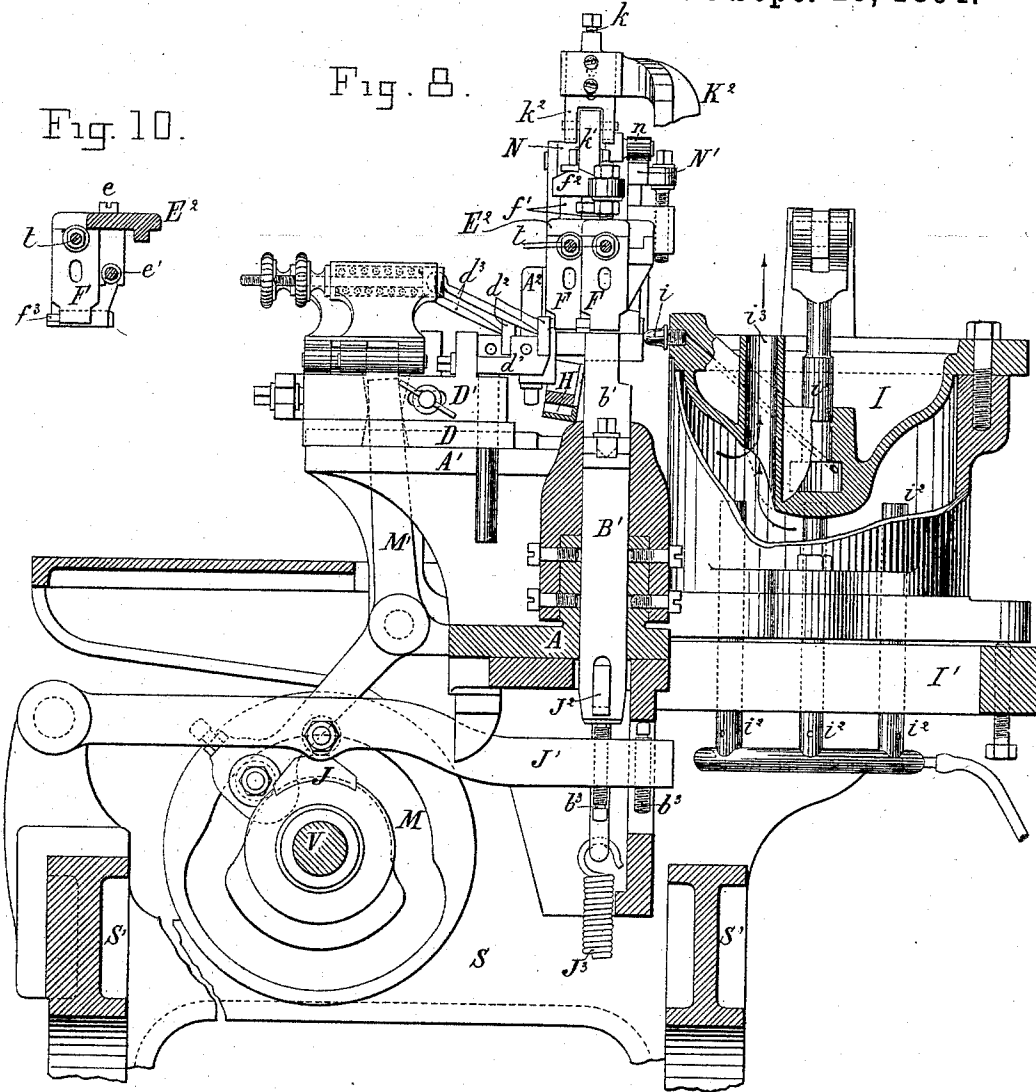

WITNESSES.

*John R. Keene*

*John Lotka*

INVENTOR:

*Auguste Foucher*

BY

*Munn & Co*

ATTORNEYS.

# UNITED STATES PATENT OFFICE.

AUGUSTE FOUCHER, OF PARIS, FRANCE.

## TYPE-FOUNDING MACHINE.

SPECIFICATION forming part of Letters Patent No. 526,569, dated September 25, 1894.

Application filed May 26, 1893. Serial No. 475,651. (No model.)

To all whom it may concern:

Be it known that I, AUGUSTE FOUCHER, machinist, of 71 Boulevard Voltaire, Paris, France, have invented new and useful Improvements in Type-Founding Machines, of which the following is a full, clear, and exact description.

My invention relates to type-founding machines in which the types are cast and dressed singly and particularly the machine forming the subject of former Letters Patent of the United States, dated the 22d day of March, 1887, No. 359,779.

The invention consists of certain features of construction and combinations of parts that will be hereinafter described and claimed.

Reference is to be had to the accompanying drawings, forming part of this specification, wherein—

Figure 1 represents a front elevation, Fig. 2 a plan with the top carriage omitted, and Fig. 3 a longitudinal section, on line 1—2 Fig. 2, of the improved machine. Fig. 4 is a detail plan of the top carriage. Figs. 5 and 6 show respectively a longitudinal and horizontal section, Fig. 7 a plan, and Fig. 10 a cross-section on line 5—6 Fig. 5, of the end of the top carriage. Fig. 8 is a cross-section of the machine, on line 3—4 Fig. 2, and Fig. 9 a corresponding part plan of same.

The machine framing is composed of standards S, S, connected by top and bottom cross-bars S', S', and in which is mounted the main shaft V for operating the various parts.

A is a fixed bed block in which are fitted to slide two vertically moving carriers B, B', for the sliding followers  $b, b'$  which form the under sides of the mold cavities and discharge the type therefrom, each moving between a pair of steel die blocks  $c, c'$ , forming the lateral sides of the two mold cavities, the die blocks,  $c$  forming the one side of the molds, being fixed to the fixed bed block A and the die blocks  $c'$  forming the other side being fixed to two bed blocks C, C', which are fixed adjustably by bolts  $c^2$  to permit of followers  $b, b'$ , of different thicknesses being used according to the letter being cast. At the front side of the mold cavities are arranged two sprue breakers  $a, a'$ , and opposite these sprue breakers are two cutters  $a^2, a^3$ , for removing the fins which form at the shoulder and edges of the

type body next to the followers  $b, b'$ , the one sprue breaker  $a$  and cutter  $a^2$  being fixed on the bed block A and the other sprue breaker  $a'$  and cutter  $a^3$  upon the adjustable bed block C'. On the front face of the bed block A is cast a bracket arm A' upon which is fitted the bed D of two matrix carriers D' which are adjustable and support the two tables  $d'$  upon which rest the two matrices  $d^2$  which are pressed against the mold by spring rods  $d^3$ .

The carriage E has at its front end an adjustable extension E' connected rigidly to it by a plate E<sup>2</sup> and screws  $e, e^2$ , the position of the extension E' being regulated by means of the adjusting screw  $e'$ . The carriage E and its extension E' each carry the usual parts employed in making the type—viz: a steel top die block  $e^3$  for the corresponding mold cavity, as shown in Fig. 3; a movable jaw F actuated in the one direction by a spring  $f$  for seizing the type on its exit from the mold and in the other direction by a traction rod  $t$  (Fig. 1) for releasing it; an ejector  $f'$  for delivering the type to the dressing or finishing devices, as shown in Fig. 3, the two ejectors  $f'$  being connected by a cross-head  $f^2$  to enable them to be operated simultaneously; a cutter  $f^3$  for removing the fins from the shoulder of the type which project beyond the surfaces of the die blocks  $c, c'$ , when the type is in the mold. The dressing or finishing devices are also duplicated, each consisting of two plates G G' (shown separately on a larger scale in Figs. 11 and 12) held apart by distance blocks and provided with cutters  $g, g'$ , for removing the lateral pins from the shoulder of the type one of the blocks  $g^2$  acting also as a cutter to form the groove between the feet of type and removing the part from which the sprue was broken. The type setting mechanism situated next to the dressing devices is also duplicated, each consisting, as usual, of a guide H curved at its upper end  $h$  serving to range the types in a line as they descend from the slot of the corresponding dressing devices and conduct them to a movable composing stick, forming a prolongation of the guide H. The pump in the melting pot I which is supported as usual upon an oscillating frame I' is provided with two injecting nozzles  $i$ , through which the molten metal is injected into the two molds by the single piston  $i'$ , but

in certain cases as for casting large type, there may be two pumps in the same melting pot, one for each mold. In order to concentrate the heat of the gas jets  $v^2$  around the nozzles  $z$ , the hot gases of combustion are caused to pass out through the three chimneys  $z^3$ .

The mechanism hereinbefore described although in duplicate is all operated by the same driving mechanism, as in the single type-founding machine, the operation being as follows:—The double carriage E, E', receives reciprocating motion from the cam L through the lever L' which has an extensible arm L<sup>2</sup> for varying the stroke of the carriage. The double matrix carrier D receives reciprocating motion from the cam M through the lever M'. The two holders B, B', carrying the mold followers  $b, b'$ , are raised simultaneously by the cam J acting on the lever J', which is forked at its extremity for the purpose, as shown in Fig. 9, and lowered by springs J<sup>3</sup>, connected to the lever J' by hooks J<sup>2</sup>; or the hooks may be connected by a cross bar, and acted on by a single spring J<sup>3</sup>, the downward movement being limited by adjustable screw-stops  $b^2$  and the upward movement by screw-stops  $b^3$ . The two type ejectors  $f'$  are actuated simultaneously by a face cam groove K acting on a lever K' connected to a frame K<sup>2</sup> sliding in vertical guides on the rear face of the mold bed A. The horizontal upper end of frame K<sup>2</sup> carries a screw-stud K which bears upon a stem K' fixed centrally on the cross-head  $f^2$ , and also a lifter fork K<sup>2</sup> for insuring the upward movement of the type ejectors  $f'$  when raised by their respective springs. The two type pushers  $f'$  are further operated simultaneously during the movement of the carriage E by means of a lever N mounted on said carriage and carrying at its tail end a roller  $n$  which rolls upon a raised cam face N' fixed adjustably upon the rear face of the bed block A. The pump piston  $v'$  is operated in the ordinary manner by a cam O acting on a lever O' connected by a rod O<sup>2</sup> with a lever O<sup>3</sup> to which the piston rod  $v'$  is attached for the purpose of raising the same, the downward stroke of the piston being produced by a spring acting on the lever O'.

The action is as follows:—In Figs. 2 and 3 the parts are shown in position for simultaneously casting the two types. The pump piston  $v'$  forces the molten metal into the two mold cavities inclosed by the steel die blocks  $c, c'$ , and  $e^3$ , the followers  $b, b'$ , and the matrices  $d^2$ . The matrix carriers D, D', are then withdrawn from the bed block A, as shown in Fig. 8, so as to disengage the matrices  $d^2$  from the type-faces, whereupon the carriage E, E', moves to the position shown in Fig. 1 during which movement the cutters  $f^3$  remove the pins from the upper edges of the shoulders of the type bodies remaining in their respective molds. In order to insure that this double cutting action may be evenly performed, the carriage E, E', is held down

upon the bed block A by means of an adjustable presser P, pivoted at  $p^2$  to the carriage, provided with a crosshead carrying two friction rollers  $p$  which travel in slots in the fixed cheeks A<sup>2</sup> forming the lateral guides for the carriage, the said rollers being caused to bear against the upper side of the slots by means of a pressure screw  $p'$ . The carriage E on the completion of its backward movement brings the two jaws F above the two mold cavities, into position for seizing the types, said jaws being opened by the nuts  $t'$  of rods  $t$  striking against a fixed abutment Q. At this moment, the mold followers  $b, b'$ , are raised and lift the two types out of their molds and enter them between the jaws F. Immediately afterward the carriage E, E', again moves forward and returns to the position shown in Fig. 3, during which movement the friction roller  $n$  rides upon the raised part of cam surface N' and the opposite end of lever N bears upon the crosshead  $f^2$ , so as to cause the type ejectors  $f'$  to simultaneously press downward upon types in the jaws F. During their forward traverse the two types come in contact with the sprue breakers  $a, a'$ , which break off the sprue or jet, at same time that the two cutters  $a^2, a^3$ , remove the fins from the under side of the type-bodies. The type-bodies having been trimmed on the two sides, it only remains to trim them on the top and bottom faces and to form the groove in the base. These two operations are performed simultaneously, when the carriage E, E', is in the position shown in Fig. 3, by the downward movement of the frame K<sup>2</sup> causing the screw-stud  $k$  to abut against the upper end of stem  $k'$  and the type-ejectors  $f'$  to descend, thus pushing the types out of the jaws F into the slots between the blocks G, G', where the lateral fins are removed by the cutters  $g, g'$ , and the groove cut in the base by the cutter  $g^2$ . The two types will then be finished, and the operation is repeated on the return of the parts to the position shown in Fig. 2. During the injection of the metal, the frame K<sup>2</sup> remains lowered and exerts pressure upon the double carriage E, E', through the screw-stud  $r$  screwed into the cross-head  $f^2$  and bearing upon the plate E<sup>2</sup>, so as to hold the two top die blocks  $e^3$  in contact with the lateral die blocks  $c, c'$ . The finished types are pushed in succession through the slots between G, G', into the guide channels  $h, H$ , and are set up in line in two movable composing sticks placed at the ends of the guides.

It will be observed that the whole of the above described operations are performed in duplicate in the present machine, in the same manner as they are performed singly in the ordinary single machine, the extent of motion of piston  $v'$ , carriage E, E', matrix carriers D, D', slides B, B', and bar K<sup>2</sup>, being the same as in said single machines. This result is obtained by arranging the duplicated parts of the machine in different longitudinal vertical planes. Thus, the second mold is situated

in a different vertical plane from the first one and not in the same line therewith, and similarly the part E' is in a different plane to the part E of the carriage, as shown in Figs. 2, 3, and 4, and particularly Fig. 6 and the matrices and injection nozzles and the blocks G, G', are arranged correspondingly, the two guide channels H, h, being arranged one below and one in front of the other in the manner of the steps of a staircase. This arrangement in echelon of the duplicated parts enables the strokes of the moving parts to remain unchanged, and so permits of obtaining, in the same time, two cast and finished types, instead of one. Moreover, it enables all parts of the machine to be overlooked by the operator, who can thus readily superintend the working.

I claim—

1. In a type-founding machine for founding two types simultaneously, the combination of two type molds, and of two sets of type finishing mechanism corresponding respectively to the two molds, the two molds and their respective sprue-breaking, body dressing and finishing mechanisms being similarly constructed and arranged the one in sequence to the other but echeloned in different vertical parallel planes, the corresponding moving parts of the two molds and finishing mechanisms being rigidly coupled together so as to be moved simultaneously in

the same directions, as and for the purpose specified.

2. In a type-founding machine for founding two types at once, the combination, with two type molds, and two sets of type-finishing mechanism corresponding respectively to the two molds, the type molds and type-finishing mechanisms being arranged in sequence in different vertical planes and their moving parts being coupled as described, of two type-setting or composing sticks likewise arranged in different vertical planes corresponding to the planes in which the molds are situated and also arranged in different horizontal planes, substantially as specified.

3. In a type-founding machine for founding two types simultaneously, comprising two type molds and two sets of type-finishing mechanism corresponding respectively to the two molds, the type molds and type-finishing mechanism being arranged in sequence in different vertical planes and their moving parts being coupled as described, the combination, with said coupled parts, of a single actuating shaft and a single set of mechanism transmitting motion therefrom to the several coupled parts, substantially as specified.

Dated this 1st day of May, 1893.

AUGUSTE FOUCHER.

Witnesses:

EMILIE HOUARD,  
JULES MATHIEU.