



(51) International Patent Classification:

A24F 47/00 (2006.01) A61M 15/00 (2006.01)
A61M 15/06 (2006.01)

(21) International Application Number:

PCT/IB2019/052319

(22) International Filing Date:

21 March 2019 (21.03.2019)

(25) Filing Language:

English

(26) Publication Language:

English

(30) Priority Data:

18164070.7 26 March 2018 (26.03.2018) EP

(71) Applicant: PHILIP MORRIS PRODUCTS S.A.
[CH/CH]; Quai Jeanrenaud 3, 2000 Neuchâtel (CH).

(72) Inventors: SANNA, Daniele; Quai Jeanrenaud 3, 2000 Neuchâtel (CH). D'AMBRA, Gianpaolo; Via Fratelli Rosselli 4, 40069 Zola Predosa (IT). CAMPITELLI, Genaro; Quai Jeanrenaud 3, 2000 Neuchâtel (CH). CAPO, Silvia; Via Fratelli Rosselli 4, 40069 Zola Predosa (IT). SPADARO, Fabiana; Quai Jeanrenaud 3, 2000 Neuchâtel (CH).

(81) Designated States (unless otherwise indicated, for every kind of national protection available): AE, AG, AL, AM, AO, AT, AU, AZ, BA, BB, BG, BH, BN, BR, BW, BY, BZ, CA, CH, CL, CN, CO, CR, CU, CZ, DE, DJ, DK, DM, DO, DZ, EC, EE, EG, ES, FI, GB, GD, GE, GH, GM, GT, HN, HR, HU, ID, IL, IN, IR, IS, JO, JP, KE, KG, KH, KN, KP, KR, KW, KZ, LA, LC, LK, LR, LS, LU, LY, MA, MD, ME, MG, MK, MN, MW, MX, MY, MZ, NA, NG, NI, NO, NZ, OM, PA, PE, PG, PH, PL, PT, QA, RO, RS, RU, RW, SA,

SC, SD, SE, SG, SK, SL, SM, ST, SV, SY, TH, TJ, TM, TN, TR, TT, TZ, UA, UG, US, UZ, VC, VN, ZA, ZM, ZW.

(84) Designated States (unless otherwise indicated, for every kind of regional protection available): ARIPO (BW, GH, GM, KE, LR, LS, MW, MZ, NA, RW, SD, SL, ST, SZ, TZ, UG, ZM, ZW), Eurasian (AM, AZ, BY, KG, KZ, RU, TJ, TM), European (AL, AT, BE, BG, CH, CY, CZ, DE, DK, EE, ES, FI, FR, GB, GR, HR, HU, IE, IS, IT, LT, LU, LV, MC, MK, MT, NL, NO, PL, PT, RO, RS, SE, SI, SK, SM, TR), OAPI (BF, BJ, CF, CG, CI, CM, GA, GN, GQ, GW, KM, ML, MR, NE, SN, TD, TG).

Published:

— with international search report (Art. 21(3))



WO 2019/186337 A1

(54) Title: INHALER WITH APERTURED POROUS SUPPORT ELEMENT

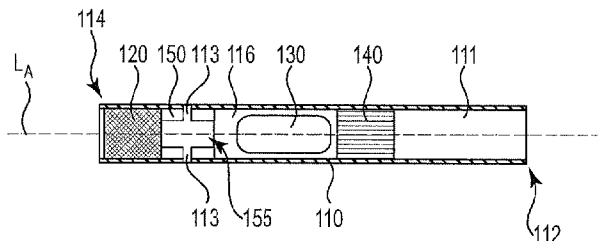

FIG. 2

(57) Abstract: An inhaler article includes a body extending from a mouthpiece end to a distal end with an endpiece element at the distal end. A capsule cavity is defined within the body and extends a cavity length. An air inlet region is between the endpiece element and the capsule cavity. The air inlet region has an air inlet and an air passageway extending from the air inlet to the capsule cavity. The air passageway has an inner diameter less than an inner diameter of the capsule cavity. A porous support element defines a downstream end of the capsule cavity. The porous support element includes one or more apertures extending the length of the porous support element.

INHALER WITH APERTURED POROUS SUPPORT ELEMENT

This disclosure relates to an inhaler article that includes a porous support element that includes one or more apertures.

5 Dry powder inhalers are not always fully suitable to provide dry powder particles to the lungs at inhalation or air flow rates that are within conventional smoking regime inhalation or air flow rates. Dry powder inhalers may be complex to operate or may involve moving parts. Dry powder inhalers often strive to provide an entire dry powder dose in a single breath. In addition, these complex dry powder inhalers are difficult to or produce at high speeds.

10 It would be desirable to provide an inhaler article that is formed of materials that form current cigarette configurations. It would be desirable to provide an inhaler article that may be assembled at high speeds. It would also be desirable to provide an inhaler article that has a form that is easy to hold and is familiar to a user, similar to a conventional cigarette. It would also be desirable to provide an inhaler article that is convenient to use by a consumer.

15 Various aspects of the disclosure relate to an inhaler article having a porous support element downstream of the capsule cavity and defining a proximal end of the capsule cavity. The porous support element is configured to confine and support a capsule at the proximal end of the capsule cavity during inhalation and rotation of the capsule. The porous support element defines one or more apertures to allow dry particles from the capsule to pass efficiently through the porous support element apertures during inhalations. The apertures are preferably located
20 about the outer perimeter of the porous support element. The porous support element may be formed of a recyclable and environmentally friendly material.

In one aspect of the disclosure, an inhaler article includes a body extending along a longitudinal axis from a mouthpiece end to a distal end with an endpiece element at the distal end. A capsule cavity is defined within the body and extends along the longitudinal axis a cavity
25 length. An air inlet region is between the endpiece element and the capsule cavity. The air inlet region has an air inlet and an air passageway extending from the air inlet to the capsule cavity. The air passageway has an inner diameter less than an inner diameter of the capsule cavity. A porous support element defines a downstream end of the capsule cavity. The porous support element is formed of a porous material. The porous support element extends along a
30 longitudinal axis a length. The porous support element includes one or more apertures extending the length of the porous support element. A mouthpiece air channel extends from the capsule cavity, through the porous support element to the mouthpiece end.

In another aspect of the disclosure, an inhaler system includes, the inhaler article described herein, and a capsule disposed within the capsule cavity of the inhaler article. The capsule contains particles having a mass median aerodynamic diameter of about 15 micrometres or less, about 10 micrometres or less, about 5 micrometres or less, or in a range from about 0.5 micrometres to about 15 micrometres, or in a range from about 1 micrometres to about 10 micrometres, or in a range from about 5 micrometres to about 10 micrometres.

In one or more aspects, the porous support element is formed of cellulose acetate material or a polylactic acid material. The cellulose acetate material and the polylactic acid material form a fiber mesh or plug of fiber material.

In one or more aspects, the porous support element includes two, three, four, five, six, or seven apertures. The apertures may be linear or curve-linear extending along the length of the porous support element. The apertures may define a helical feature along the length of the porous support element.

In one or more aspects, the porous support element includes two or more apertures along an outer diameter of the porous support element. The porous support element may further include a central aperture coincident with the center of the porous support element. The porous support element may not further include a central aperture coincident with the center of the porous support element.

In one or more aspects, the endpiece element may substantially prevent or inhibit air from entering the inhaler article from the distal end. In some embodiments, the endpiece element may prevent air from entering the inhaler article through the distal end.

In one or more aspects, the air passageway may include an inner diameter smaller than an inner diameter of the capsule cavity. The inner diameter of the air passageway may be in a range from about 2 mm to about 4.5 mm, or from about 3 mm to about 4 mm.

In one or more aspects, the air inlet region induces a vortex of inhalation air airflow into the capsule cavity. The air inlet region includes a vortex tunnel that induces a vortex of inhalation air airflow into the capsule cavity. The vortex tunnel has an inner diameter that is less than an inner diameter of the capsule cavity. The vortex tunnel may have an inner diameter of about 2 mm to about 4.5 mm. The inner diameter of the vortex tunnel may be in a range from about 3 mm to about 4 mm.

In one or more aspects, the body of the inhaler article has an outer diameter that may be substantially constant from the distal end to the mouthpiece end. The outer diameter of the body may be in a range from about 6 mm to about 10 mm, or from about 7 mm to about 8 mm.

5 In one or more aspects, the endpiece may extend longitudinally along the longitudinal axis of the body of the inhaler article. The endpiece may have a length in a range from about 5 mm to about 10 mm, and the vortex capsule cavity may extend longitudinally along the longitudinal axis of the body a length in a range from about 15 mm to about 25 mm.

In one or more aspects, the system may include a capsule containing pharmaceutically active particles comprising nicotine.

10 In one or more aspects, the system may include a capsule further containing a second population of flavor particles.

In one or more aspects, the system may further include a piercing element removably engageable with the inhaler article to activate the capsule. As used herein "activating" a capsule refers to opening a capsule, such as by piercing, to enable particles contained within the capsule to be released. The endpiece element may be configured to be pierced by the piercing element when activating the capsule.

Advantageously, the inhaler article may be formed of materials used to assemble conventional cigarettes. In addition, the inhaler article define a form similar to a conventional cigarette. This may enable high speed assembly or manufacture of the inhaler article.

20 Advantageously, rotation of the capsule may provide a uniform entrainment of a portion or a fraction of pharmaceutically active particles from the capsule over two or more, or five or more, or ten or more inhalations or "puffs" by a consumer. Advantageously, the inhaler article may be formed of biodegradable materials.

The inhaler article described herein may provide dry powder to the lungs at inhalation or air flow rates that are within conventional smoking regime inhalation or air flow rates. A consumer may take a plurality of inhalations or "puffs" where each "puff" delivers a fractional amount of dry powder contained within a capsule contained within the capsule cavity. This inhaler article may have a form similar to a conventional cigarette and may mimic the ritual of conventional smoking. This inhaler may be simple to manufacture and convenient to use by a consumer.

30

Air flow management through the capsule cavity may cause the capsule to rotate during inhalation and consumption. The capsule contains pharmaceutically active particles and optionally particles comprising flavour (also referred to as "flavour particles). Rotation of the pierced capsule may suspend and aerosolize the pharmaceutically active particles released from the pierced capsule into the inhalation air moving through the inhaler article. The flavour particles may be larger than the pharmaceutically active particles and may assist in transporting the pharmaceutically active particles into the lungs of the user while the flavour particles preferentially remain in the mouth or buccal cavity of the user. The pharmaceutically active particles and optional flavor particles may be delivered with the inhaler article at inhalation or air flow rates that are within conventional smoking regime inhalation or air flow rates.

The phrase "resistance to draw" or "RTD" refers to the static pressure difference between the two ends of a specimen when it is traversed by an air flow under steady conditions in which the volumetric flow is 17.5 millilitres per second at the output end. The RTD of a specimen can be measured using the method set out in ISO Standard 6565:2002.

The term "porous" refers to a material containing pores. In particular porous refers to a non-woven fiber material that is formed of a fiber matrix defining pores. The porous material has a "resistance to draw" or "RTD" that is greater than about 20 mm water.

The term "aperture" refers to a macroscopic void that is defined by bulk porous material. The aperture has a "resistance to draw" or "RTD" that is less than about 1 mm water.

The term "nicotine" refers to nicotine and nicotine derivatives such as free-base nicotine, nicotine salts and the like.

The term "flavourant" or "flavour" refers to organoleptic compounds, compositions, or materials that alter and are intended to alter the taste or aroma characteristics of nicotine during consumption or inhalation thereof. The term "flavourant" or "flavour" preferably refers to compounds disclosed in the Flavor & Extract Manufacturers Association (FEMA) Flavor Ingredient Library and in particular in the GRAS Flavoring Substances publications 3 to 27, for example, see Hall, R.L. & Oser, B.L., Food Technology, February 1965 pg. 151-197, and in the GRAS flavoring substances 27 S.M. Cohen et al., Food Technology Aug. 2015 pg. 40-59, and intervening GRAS Flavoring Substances publications 4 to 26. For the purpose of this disclosure, nicotine is not considered as a flavourant or flavour.

The inhaler article described herein may be combined with a piercing element or piercing device to deliver the pharmaceutically active particles to a consumer. The piercing element or piercing device may be separated from or not form a portion of the inhaler article. A plurality of these inhaler articles may be combined with a piercing element or piercing device to form a kit.

5 An inhaler article, according to the disclosure, includes a body extending along a longitudinal axis from a mouthpiece end to a distal end. An endpiece element is located at the distal end. A capsule cavity is defined within the body and extends along the longitudinal axis. A mouthpiece air channel extends from the capsule cavity to the mouthpiece end. An air inlet region is between the endpiece element and the capsule cavity. The air inlet region has an air inlet and an air passageway extending from the air inlet to the capsule cavity. A porous support element defines a downstream end of the capsule cavity. The porous support element is formed of a porous material. The porous support element extends along a longitudinal axis a length. The porous support element includes one or more apertures extending the length of the porous support element. A mouthpiece air channel extends from the capsule cavity, through the porous support element to the mouthpiece end.

10

15

The body of the inhaler article, or the "inhaler body", may have any suitable shape. The inhaler body may be elongate. In other words, the inhaler body may have a length that is substantially greater than the other dimensions of the inhaler body. The inhaler body may have a substantially uniform outer diameter along its length. The inhaler body may have any suitable transverse cross-sectional shape. For example, the transverse cross-section may be circular, elliptical, square or rectangular. The inhaler body may have a circular cross-section that may be uniform along the length of the inhaler body, forming an elongated cylindrical body.

20

The body of the inhaler article, or "inhaler body" may resemble a smoking article or conventional cigarette in size and shape. The inhaler body may have an elongated cylindrical body extending along the longitudinal axis of the inhaler article. The inhaler body may have a substantially uniform outer diameter along the length of the elongated cylindrical body. The inhaler body may have a circular cross-section that may be uniform along the length of the elongated cylindrical body.

25

The inhaler body may have an outer diameter in a range from about 6 mm to about 10 mm, or from about 7 mm to about 10 mm, or about 7 mm to about 9 mm, or about 8 mm. The inhaler body may have a length (along the longitudinal axis) in a range from about 40 mm to

30

about 100 mm, or from about 50 mm to about 80 mm, or about 60 mm to about 80 mm, or 65 mm.

The inhaler body may be formed of a polymeric or cellulosic material, or any other suitable material. The inhaler body may be formed of a biodegradable material. The inhaler
5 body may be formed of paperboard or cardboard. The inhaler body may have a uniform thickness along its length. The inhaler body may have a thickness in a range from about 1 mm to about 2 mm.

The inhaler body may form a unitary construction where the body extends continuously from the endpiece element to the mouthpiece end. The endpiece element, air inlet region,
10 capsule cavity (and capsule if present), porous support element and mouthpiece air channel may be serially disposed within the inhaler body. In other words, endpiece element, air inlet region, capsule cavity (and capsule if present), porous support element and mouthpiece air channel may be arranged end to end along the longitudinal axis of the inhaler body.

The inhaler body may be formed of two portions, a first portion and a second portion.
15 The first portion and the second portion may be axially aligned in serial abutting relationship and joined together to form the inhaler body. A wrapper may be utilized to join the first portion and a second portion together. The wrapper may be a biodegradable material. The wrapper may be a paper wrapper.

The first portion may contain the mouthpiece or mouthpiece air channel, and porous
20 support element. The second portion may contain the capsule cavity (and capsule if present), air inlet region, and endpiece element.

In some embodiments, the inhaler body may be formed of three portions, or more than three portions. The three portions, or more than three portions may be axially aligned in serial abutting relationship and joined together to form the inhaler body. A wrapper may be utilized to
25 join the three portions, or more than three portions together.

The porous support element is a non-woven fibre element that includes one or more apertures extending the longitudinal length of the porous support element. The bulk porous (non-woven fibre element) material forming the porous support element defines the one or more apertures extending the longitudinal length of the porous support element. The one or more
30 apertures are configured and placed on or within the porous support element to enhance dry particle delivery from the capsule in the capsule cavity, across the porous support element, to

the mouthpiece end, during each inhalation event. The one or more apertures are configured and placed on or within the porous support element to minimize particle recirculation near or across the porous support element. These features may improve the delivery of the dry particles to the mouthpiece or enhance the emptying of the dry particles from the inhaler during
5 inhalations.

The one or more apertures may extend linearly along the longitudinal length of the porous support element. The one or more apertures may extend curve-linearly along the longitudinal length of the porous support element. The one or more apertures may extend helically along the longitudinal length of the porous support element. The one or more apertures
10 may extend linearly and parallel with and along the longitudinal axis of the porous support element. Preferably the one or more apertures may extend along the outer diameter of the porous support element.

The porous support element may have a length that extends along the longitudinal axis of the inhaler body. The porous support element may have any suitable length, such as
15 between about 5 mm to about 10 mm. The porous support element may substantially fill the inner diameter of the inhaler body (including the porous support element apertures). The porous support element may have an outer diameter sufficient to form a friction fit with the inner diameter of the inhaler body. The porous support element may have an outer diameter in a range from about 7 mm to about 8 mm.

The apertures defined by the porous support element may make up at least about 40%,
20 or in a range from about 15% to about 60% of a circular cross-sectional surface area of the porous support element. The apertures defined by the porous support element may make up a range from about 25% to about 60% of a circular cross-sectional surface area of the porous support element. The apertures defined by the porous support element may make up a range
25 from about 35% to about 60% of a circular cross-sectional surface area of the porous support element. The apertures defined by the porous support element may make up a range from about 45% to about 60% of a circular cross-sectional surface area of the porous support element. The apertures defined by the porous support element may make up a range from about 25% to about 50% of a circular cross-sectional surface area of the porous support
30 element.

The apertures defined by the porous support element may have an axial cross-sectional lateral length in a range from about 0.5 to about 5 mm. The apertures defined by the porous

support element may have an axial cross-sectional lateral length in a range from about 1 to about 4 mm. The apertures defined by the porous support element may have an axial cross-sectional lateral length in a range from about 1.5 to about 3 mm.

5 The porous support element includes two, three, four, five, six, or seven apertures. The apertures may be linear or curve-linear extending along the length of the porous support element. The apertures may define a helical feature along the length of the porous support element.

10 The porous support element may include two, or more apertures that are defined on all sides by the bulk porous material of the porous support element. The apertures may have any curved or polygonal shape. The apertures may have a circular shape. The apertures may have an elliptical shape. The apertures may have a rectangular shape. The apertures may have a triangular shape.

15 The porous support element may include two, or more apertures that define an outer diameter of the porous support element. These outer diameter apertures may have a scalloped, or semi-circular shape. The porous support element may include two or more apertures along an outer diameter of the porous support element. The porous support element may include two, three, four, five, six, or more apertures along an outer diameter of the porous support element. These outer diameter apertures may be equally spaced about the outer diameter of the porous support element. The porous support element may further include a central aperture coincident with the center of the porous support element. The porous support element may not further include a central aperture coincident with the center of the porous support element. The apertures may define a helical feature along the length of the porous support element and along the outer surface of the porous support element.

25 The porous support element may be formed from a non-woven fibre plug of cellulose acetate material. The bulk plug of cellulose acetate material may have a "resistance to draw" in a range from about 10 to about 50 mm water, or in a range from about 30 to about 75 mm water. The bulk plug of cellulose acetate material may have a denier in a range from about 3.4 to about 8, or from about 3.7 to about 7, or from about 4 to about 6.

30 The porous support element may be formed from both a non-woven fibre plug of cellulose acetate material and polylactic acid material.

An endpiece element may be disposed within the distal or endpiece end of the inhaler body. The endpiece element is configured to restrict or prevent airflow through the distal or endpiece end of the body of the inhaler article. The endpiece element is configured to encourage airflow to enter the inhaler body through air inlets along the sidewall of the body, as described below, preferentially over air flowing through the endpiece element.

Where the endpiece element permits some air to enter the inhaler body through the distal end, the endpiece element has a generally high resistance to draw (RTD). The endpiece element may have an RTD of greater than about 30 mm water, or greater than about 50 mm water, or greater than about 75 mm water, or greater than 100 mm water, or greater than 200 mm water, or in a range from 30 mm water to 100 mm water.

The endpiece element may extend longitudinally along the longitudinal axis of the inhaler body. The endpiece element may have a length in a range from about 5 mm to about 10 mm.

The endpiece element may be formed of any suitable material. For example, the endpiece element may be formed of viscose paper. The endpiece element may be formed of fibers forming a tow material, or a plug of tow material. The endpiece element may be formed of a biodegradable material. The endpiece element may be formed of cellulose or cellulose acetate. The endpiece element may be formed of an acetate tow. The endpiece element may be formed of a cellulose tow. The endpiece element may be formed of an acetate and cellulose tow. The endpiece element may be formed of cellulose and viscose paper.

The endpiece element may form a cylindrical plug of material that may fill the distal end of the inhaler article body. This cylindrical plug of material may be a tow material. The cylindrical plug of material may be cellulose or cellulose acetate materials. The cylindrical plug of material may be acetate tow. The cylindrical plug of material may be cellulose tow. The cylindrical plug of material may be an acetate and cellulose tow. The cylindrical plug of material may be cellulose and viscose paper. In one or more aspects, the endpiece element may be formed of cellulose or acetate, fibers or tow, or viscose paper.

The endpiece element may be pierceable. A piercing element such as a rigid elongate needle, may pierce the endpiece element and pass through the vortex tunnel to contact a capsule within the capsule cavity and form a hole in the capsule. Particles contained within the capsule may then exit the hole formed by the piercing element during use of the inhaler article.

In some embodiments, the endpiece element may at least partially reseal once the piercing element is withdrawn from the endpiece element.

An air inlet region is positioned between the endpiece element and the capsule cavity. The air inlet region may abut the endpiece element. The air inlet region may be axially aligned and in serial arrangement with the endpiece element. The air inlet region may form an upstream or distal end or boundary of the capsule cavity.

The air inlet region includes an air passageway extending from the air inlet to the capsule cavity. The air passageway has an inner diameter less than an inner diameter of the capsule cavity. The air passageway may have an inner diameter in a range from about 60% to about 25% of the outer diameter of the air inlet region or the inner diameter of the body or the inner diameter of the capsule cavity, or the air passageway inner diameter may be in a range from about 50% to about 35% of the outer diameter of the air inlet region or of the inner diameter of the body or the inner diameter of the capsule cavity. The air passageway may have an inner diameter in a range from about 2 mm to about 4.5 mm. The capsule cavity may have an inner diameter of about 7 mm to about 8 mm.

The air inlet region may be configured to initiate a "swirling" or vortex of inhalation air into the capsule cavity. The air inlet region may include two more air inlets spaced around the circumference of the inhaler body. In one more aspects, the air inlet region includes a vortex tunnel. The vortex tunnel is configured to induce swirling or induce a vortex of inhalation airflow through the capsule cavity of the inhaler. The vortex tunnel may define an open cylinder where the air passageway extends substantially co-axially along the axis of the cylinder. The air passageway may have an inner diameter less than an inner diameter of the capsule cavity. The axis of this open cylinder may be co-extensive with the longitudinal axis of the inhaler article body. The vortex tunnel may extend longitudinally along the longitudinal axis of the inhaler article body a length that is greater than an inner diameter of the vortex tunnel.

The vortex tunnel may include an air inlet in fluid communication with the air passageway. The air passageway may define an inner passageway of the open cylinder. The air passageway is defined by the inner diameter or the vortex tunnel. The inner diameter of the vortex tunnel is less than an inner diameter of the inhaler body. The inner diameter of the vortex tunnel is less than an inner diameter of the capsule cavity.

The air inlet provides an opening for air to enter the air passageway or open cylinder from outside the inhaler article. The air inlet may extend through a sidewall (or thickness) of the

vortex tunnel. In some embodiments, the air inlet extends through the body of the inhaler article. In some embodiments, the body of the inhaler article also comprises an air inlet. The air inlet of the body of the inhaler article may be aligned with the air inlet of the vortex tunnel. Where the vortex tunnel comprises more than one air inlet, the body of the inhaler article may comprise a
5 complimentary number of air inlets, each air inlet of the inhaler body being aligned with or registered with an air inlet of the vortex tunnel.

The vortex tunnel may have an outer diameter in contact with the inner diameter of the body. The vortex tunnel may have an inner diameter in a range from about 60% to about 25% of the outer diameter of the vortex tunnel or the inner diameter of the body or the inner diameter of
10 the capsule cavity, or the vortex tunnel inner diameter may be in a range from about 50% to about 35% of the outer diameter of the vortex tunnel or of the inner diameter of the body or the inner diameter of the capsule cavity. The vortex tunnel may have a length greater than the inner diameter of the vortex tunnel. In other words, the inner diameter of the vortex tunnel may be narrow or thin relative to the outer diameter of the vortex tunnel.

The vortex tunnel may have an outer diameter substantially equal to the inner diameter
15 of the inhaler article body. The vortex tunnel may have an inner diameter that is less than the outer diameter of a capsule disposed within the capsule cavity. The vortex tunnel may have an outer diameter of about 7 mm to about 8 mm. The capsule cavity may have an inner diameter of about 7 mm to about 8 mm. The vortex tunnel may have an inner diameter of about 2 mm to
20 about 4.5 mm, or from about 3 mm to about 4 mm. The vortex tunnel may have a wall thickness in a range from about 2 mm to about 3 mm. The vortex tunnel may extend longitudinally along the longitudinal axis of the inhaler article body a length in a range from about 5 mm to about 10 mm.

The air inlet may meet or enter the air passageway of the vortex tunnel at a tangent to at
25 least one of the surfaces (inner diameter of the vortex tunnel) and the air passageway. In particular the air inlet may extend substantially at a tangent to the axis of the inhaler body. The vortex tunnel may include two air inlets in communication with the air passageway. The vortex tunnel may include two opposing air inlets entering the open cylinder at a tangent to the inner diameter of the open cylinder. Providing one or two opposing air inlets at a tangent to the inner
30 diameter of the open cylinder induces a swirling or vortex air flow pattern within the capsule cavity of the inhaler body.

The one or more air inlet(s) may have any suitable or useful shape. The one or more air inlet(s) may have a cylindrical shape or circular cross-section. The one or more air inlet(s) may have a diameter in a range from about 0.8 mm to about 1.2 mm, or about 1 mm. The one or more air inlet(s) may be formed by mechanical puncturing or by laser perforation.

5 The air inlet region or vortex tunnel may be formed of any useful material. For example, the air inlet region or vortex tunnel may be formed of cellulose acetate tow. The air inlet region or vortex tunnel may be formed of paperboard or cardboard. The air inlet region or vortex tunnel may be formed of a polymeric material.

10 The vortex tunnel may be constructed from a hollow cellulose acetate tube (may be referred to as "HAT"). The vortex tunnel may be formed of a hollow cellulose acetate tube or open cylinder of cellulose acetate tow. Paper may line at least one of the inner diameter and outer diameter of the vortex tunnel. The vortex tunnel may be formed of an open cylinder of cellulose acetate tow with paper lining the inner diameter. The vortex tunnel may be formed of an open cylinder of cellulose acetate tow with paper lining the outer diameter. The vortex tunnel
15 may be formed of an open cylinder of cellulose acetate tow with paper lining both the inner diameter and outer diameter of this vortex tunnel (may be referred to as a "diffuser plug").

20 The capsule cavity may be immediately downstream from the air inlet region or vortex tunnel. The capsule cavity may abut the air inlet region or vortex tunnel. The capsule cavity may be axially aligned and in serial arrangement with the air inlet region or vortex tunnel. The air inlet region or vortex tunnel may form an upstream or distal end or boundary of the capsule cavity.

25 The capsule cavity may define a cylindrical space configured to contain a capsule. The capsule cavity may define a space configured to receive a capsule having an obround or rounded rectangular shape. The capsule cavity may have a substantially uniform or uniform diameter along the length of the capsule cavity. The capsule cavity may have a circular transverse cross-section along the length of the capsule cavity. The capsule cavity may have a cylindrical shape. The configuration of the capsule cavity relative to the capsule may allow the capsule to rotate with stability within the capsule cavity. The longitudinal axis of the capsule may rotate with stability about the longitudinal axis of the inhaler body during inhalation.

30 Stable rotation refers to the longitudinal axis of the inhaler body being substantially parallel with the axis of rotation of the capsule. Stable rotation may refer to the absence of procession of the rotating capsule. Preferably the longitudinal axis of the inhaler body may be

substantially coextensive with the axis of rotation of the capsule. Stable rotation of the capsule may provide a uniform entrainment of a portion of pharmaceutically active particles from the capsule over two or more, or five or more, or ten or more “puffs” by a consumer.

5 The capsule cavity may have a fixed cavity length bounded on an upstream or distal end by the air inlet region and bounded on the downstream end by the porous support element. The capsule cavity may have a cavity length of about at least about 110% to less than about 200% of a length of the capsule contained therein, or from about 120% to about 130% of the capsule length, or about 125% of the capsule length. The cavity length may be in a range from about 15 mm to about 25 mm and the capsule length may be in a range from about 14 to about 18 mm,
10 or the cavity length may be about 20 mm and the capsule length may be about 16 mm.

The capsule cavity has a cavity inner diameter, orthogonal to the longitudinal axis, and the capsule has a capsule outer diameter. The capsule outer diameter may be in a range from about 80% to about 99% of the cavity inner diameter, or capsule outer diameter may be in a range from about 85% to about 95% of the cavity inner diameter, or capsule outer diameter may
15 be about 90% of the cavity inner diameter. The capsule outer diameter may be in a range from about 5.4 mm to about 6.4 mm and the cavity inner diameter may be in a range from about 6 mm to about 7 mm.

The capsule cavity may be bounded on an upstream distal side by the air inlet region and bounded on a downstream or mouthpiece side by the porous support element. The air inlet
20 region and porous support element may cooperate to contain the capsule longitudinally within the capsule cavity. The porous support element may fill the inner diameter of the elongated inhaler body. The porous support element may allow air flow to exhibit a uniform airflow along the cross-section of the elongated inhaler body through the porous support element. The porous support element may function as a diffuser to reduce turbulence effects or edge effects and
25 ensure or maintain the desired air flow pattern through the capsule cavity. The porous support element may support a capsule inside the capsule cavity during activation of the capsule, such as by providing a support for the capsule as a piercing element is received in the inhaler article at the distal end and pierces the capsule to activate the capsule.

A capsule may be sealed within the inhaler article prior to consumption. For transport
30 and storage, the inhaler article may be contained within a sealed or airtight container or bag. The inhaler article may include one or more peelable seal layers to cover the one or more air inlet channels or the air outlet or mouthpiece of the inhaler article. This may ensure the inhaler

articles maintain appropriate hygiene and freshness or may prevent the capsule from drying out and becoming hard or friable.

The capsule may rotate about its longitudinal or central axis when air is drawn through the inhaler article. The capsule may be formed of an airtight material that substantially contains the particles inside the capsule. The capsule may be configured to be pierced or punctured by a piercing element when the capsule is within the capsule cavity. The piercing element may be separate or combined with the inhaler article. The capsule may be formed of any suitable material. The capsule may be formed of a metallic or polymeric material that serves to keep contaminants out of the capsule but may be pierced or punctured by a piercing element prior to consumption to enable the release of the pharmaceutically active particles from within the capsule. The capsule may be formed of a polymer material. The polymer material may be hydroxypropylmethylcellulose (HPMC). The capsule may be any suitable size. The capsule may be a size 1 to size 4 capsule, or a size 3 capsule, or a size 2 capsule.

The system may comprise a separate piercing element, such as a metal or rigid needle. The piercing element may form a single aperture through the capsule received in the capsule cavity. The piercing element may be configured to pass through the endpiece element and through the air passageway of the vortex tunnel into the capsule cavity. Preferably, the endpiece element is resealable after the piercing element has been withdrawn from the inhaler article, to enhance the swirling or vortex of inhalation air through the capsule cavity. In some embodiments, the inhaler article may comprise a resealable element for sealing the endpiece element after the piercing element has been withdrawn from the inhaler article.

The capsule contains a dry powder comprising pharmaceutically active particles and optionally flavour particles. The capsule may contain a predetermined amount of dry powder. The capsule may contain enough dry powder to provide at least 2 inhalations or "puffs", or at least about 5 inhalations or "puffs", or at least about 10 inhalations or "puffs". The capsule may contain enough dry powder to provide from about 5 to about 35 inhalations or "puffs", or from about 8 to about 25 inhalations or "puffs". Each inhalation or "puff" releases an approximate or substantially equal or equivalent amount of dry powder into the inhalation air stream.

The capsule may contain a dry powder about 50% to about 95% by weight pharmaceutically active particles and from 50% to 5% by weight flavour particles, or from 70% to about 90% by weight pharmaceutically active particles and from 30% to 10% by weight

flavour particles. The capsule may contain from 30 mg to 70 mg of dry powder, or from 40 mg to 60 mg of dry powder.

Preferably, the capsule contains pharmaceutically active nicotine particles and flavour particles. The capsule may contain a dry powder about 50% to about 95% by weight nicotine particles and from 50% to 5% by weight flavour particles, or from 70% to about 90% by weight nicotine particles and from 30% to 10% by weight flavour particles. The capsule may contain from 30 mg to 70 mg of dry powder, or from 40 mg to 60 mg of dry powder. The nicotine particles may contain from about 1% to about 10% effective nicotine, or from about 3% to about 7% effective nicotine, or about 5% effective nicotine.

When flavour particles are blended or combined with the pharmaceutically active particles within the capsule, the flavour particles are present in an amount that provides the desired flavour to each inhalation or "puff" delivered to the user.

The pharmaceutically active particles may have any useful size distribution for inhalation delivery preferentially into the lungs of a user. The capsule may include other particles than the pharmaceutically active particles. The pharmaceutically active particles and the other particles form a powder system.

The powder system may have at least about 40% or at least about 60%, or at least about 80%, by weight of the powder system comprised in pharmaceutically active particles having a particle size of about 10 micrometres or less, or 5 micrometers or less, or in a range from about 1 micrometer to about 3 micrometres.

The powder system may have at least about 40% or at least about 60%, or at least about 80%, by weight of the powder system comprised in pharmaceutically active particles having a particle size of about 10 micrometres or less, or 5 micrometers or less, or in a range from about 1 micrometer to about 3 micrometres.

The pharmaceutically active particles may have a mass median aerodynamic diameter of about 5 micrometres or less, or in a range from about 0.5 micrometres to about 4 micrometres, or in a range from about 1 micrometres to about 3 micrometres or in a range from about 1.5 micrometres to about 2.5 micrometres. The mass median aerodynamic diameter is preferably measured with a cascade impactor.

The particles comprising nicotine may have a mass median aerodynamic diameter of about 5 micrometres or less, or in a range from about 0.5 micrometres to about 4 micrometres, or in a range from about 1 micrometres to about 3 micrometres or in a range from about 1.5 micrometres to about 2.5 micrometres. The mass median aerodynamic diameter is preferably measured with a cascade impactor.

The particles comprising flavour may have a mass median aerodynamic diameter of about 20 micrometres or greater, or about 50 micrometres or greater, or in a range from about 50 to about 200 micrometres, or from about 50 to about 150 micrometres. The mass median aerodynamic diameter is preferably measured with a cascade impactor.

The dry powder may have a mean diameter of about 60 micrometres or less, or in a range from about 1 micrometres to about 40 micrometres, or in a range from about 1.5 micrometres to about 25 micrometres. The mean diameter refers to the mean diameter per mass and is preferably measured by laser diffraction, laser diffusion or an electronic microscope.

Preferably the pharmaceutically active particles are nicotine particles. Nicotine in the powder system or nicotine particles is preferably a pharmaceutically acceptable free-base nicotine, or nicotine salt or nicotine salt hydrate. Useful nicotine salts or nicotine salt hydrates include nicotine pyruvate, nicotine citrate, nicotine aspartate, nicotine lactate, nicotine bitartrate, nicotine salicylate, nicotine fumarate, nicotine mono-pyruvate, nicotine glutamate or nicotine hydrochloride, for example. The compound combining with nicotine to form the salt or salt hydrate may be chosen based on its expected pharmacological effect.

The nicotine particles preferably include an amino acid. Preferably the amino acid is leucine such as, L-leucine. Providing an amino acid such as L-leucine with the particles comprising nicotine, may reduce adhesion forces of the particles comprising nicotine and may reduce attraction between nicotine particles and thus reduce agglomeration of nicotine particles.

Similarly, adhesion forces to particles comprising flavour is also reduced thus agglomeration of pharmaceutically active particles with flavour particles is also reduced. The powder system described herein thus may be a free-flowing material and possess a stable relative particle size of each powder component even when the pharmaceutically active particles and the flavour particles are combined.

The powder system may include flavour particles. The flavour particles may have any useful size distribution for inhalation delivery selectively into the mouth or buccal cavity of a user.

The powder system may have at least about 40%, or at least about 60%, or at least about 80%, by weight of the flavour particles of the powder system comprised in particles having a particle size of about 20 micrometres or greater. The powder system may have at least about 40% or at least about 60%, or at least about 80%, by weight of the flavour particles of the powder system comprised in particles having a particle size of about 50 micrometres or greater. The powder system may have at least about 40% or at least about 60%, or at least about 80%, by weight of the flavour particles of the powder system comprised in particles having a particle size in a range from about 50 micrometer to about 150 micrometres. Flavourants or flavours may be provided as a solid flavour (at room temperature of about 22 degrees centigrade and one atmosphere pressure) and may include flavour formulations, flavour-containing materials and flavour precursors. The flavourant may include one or more natural flavourants, one or more synthetic flavourants, or a combination of natural and synthetic flavourants. Flavourants as described herein are organoleptic compounds, compositions, or materials that are selected and utilized to alter or are intended to alter the taste or aroma characteristics of the pharmaceutically active or nicotine component during consumption or inhalation thereof.

Flavourants or flavours refer to a variety of flavour materials of natural or synthetic origin. They include single compounds and mixtures. The flavour or flavourant has flavour properties that may enhance the experience of the pharmaceutically active or nicotine component during consumption. The flavour may be chosen to provide an experience similar to that resulting from smoking a combustible smoking article. For example, the flavour or flavourant may enhance flavour properties such as mouth fullness and complexity. Complexity is generally known as the overall balance of the flavour being richer without dominating single sensory attributes. Mouth fullness is described as perception of richness and volume in the mouth and throat of the consumer.

Suitable flavours include, but are not limited to, any natural or synthetic flavour, such as tobacco, smoke, menthol, mint (such as peppermint and spearmint), chocolate, licorice, citrus and other fruit flavours, gamma octalactone, vanillin, ethyl vanillin, breath freshener flavours, spice flavours such as cinnamon, methyl salicylate, linalool, bergamot oil, geranium oil, lemon oil, and ginger oil, and the like.

Other suitable flavours may include flavour compounds selected from the group consisting of an acid, an alcohol, an ester, an aldehyde, a ketone, a pyrazine, combinations or blends thereof and the like. Suitable flavour compounds may be selected, for example, from the group consisting of phenylacetic acid, solanone, megastigmatrienone, 2-heptanone, 5 benzylalcohol, cis-3-hexenyl acetate, valeric acid, valeric aldehyde, ester, terpene, sesquiterpene, nootkatone, maltol, damascenone, pyrazine, lactone, anethole, iso-s valeric acid, combinations thereof, and the like.

Further specific examples of flavours may be found in the current literature, and are well-known to the person skilled in the art of flavouring, i.e. of imparting an odor or taste to a product.

10 The flavourant may be a high potency flavourant, and may be used and detected at levels that would result in less than 200 parts per million in inhalation air flow. Examples of such flavourants are key tobacco aroma compounds such as beta-damascenone, 2-ethyl-3,5-dimethylpyrazine, phenylacetaldehyde, guaiacol, and furaneol. Other flavourants may only be sensed by humans at higher concentration levels. These flavourants, which are referred to 15 herein as the lower potency flavourants, are typically used at levels that results in orders of magnitude higher amounts of flavourant released into the inhalation air. Suitable lower potency flavourants include, but are not limited to, natural or synthetic menthol, peppermint, spearmint, coffee, tea, spices (such as cinnamon, clove and ginger), cocoa, vanilla, fruit flavours, chocolate, eucalyptus, geranium, eugenol and linalool.

20 The particles comprising flavour may include a compound to reduce adhesion forces or surface energy and resulting agglomeration. The flavour particle may be surface modified with an adhesion reducing compound to form a coated flavour particle. One preferred adhesion reducing compound may be magnesium stearate. Providing an adhesion reducing compound such as magnesium stearate with the flavour particle, especially coating the flavour particle, 25 may reduce adhesion forces of the particles comprising flavour and may reduce attraction between flavour particles and thus reduce agglomeration of flavour particles. Thus agglomeration of flavour particles with pharmaceutically active or particles may also be reduced. The powder system described herein thus may possess a stable relative particle size of the particles comprising pharmaceutically active or and the particles comprising flavour even when 30 the pharmaceutically active or particles and the flavour particles are combined. The powder system preferably free-flowing.

Conventional formulations for dry powder inhalation typically contain carrier particles that serve to increase the fluidization of the active particles since the active particles may be too small to be influenced by simple airflow through an inhaler. These powder systems typically require carrier particles. These carrier particles may be a saccharide such as lactose or mannitol that have a particle size greater than about 50 micrometres. The carrier particles may be utilized to improve dose uniformity by acting as a diluent or bulking agent in a formulation. These conventional formulations typically require high speed inhalation airflows and degglomeration elements and sieve elements to achieve a particle size that will enter the pulmonary system. Inhalation airflow boosting elements, degglomeration elements, and sieve elements add complexity and cost of the dry powder inhaler.

The powder system utilized with the dry powder inhaler of the invention may be carrier-free or substantially carrier-free. Being carrier-free or substantially carrier-free may allow the dry powder and to be inhaled and the pharmaceutically active particles be delivered to the user's lungs at inhalation or airflow rates that are similar to typical smoking regime inhalation or airflow rates. Preferably any carrier-like particles are limited to the flavour particles or flavour component of the dry power system.

The dry powder system may be combined in a single capsule. As described above, the dry powder system may each have reduced adhesion forces that result in a stable powder formulation where the particle size of each component does not substantially change when combined.

The inhaler and inhaler system may be less complex and have a simplified airflow path as compared to conventional dry powder inhalers. Advantageously, rotation of the capsule within the inhaler body aerosolizes the pharmaceutically active particles or powder system and may assist in maintaining a free-flowing powder. Thus, the inhaler article may not require the elevated inhalation rates typically utilized by conventional inhalers to deliver the pharmaceutically active particles described above deep into the lungs.

The inhaler article may use a flow rate of less than about 5 L/min or less than about 3 L/min or less than about 2 L/min or about 1.6 L/min. Preferably, the flow rate may be in a range from about 1 L/min to about 3 L/min or from about 1.5 L/min to about 2.5 L/min. Preferably, the inhalation rate or flow rate may be similar to that of Health Canada smoking regime, that is, about 1.6 L/min.

The inhaler may be used by a consumer like smoking a conventional cigarette or vaping an electronic cigarette. Such smoking or vaping may be characterized by two steps: a first step during which a small volume containing the full amount of nicotine desired by the consumer is drawn into the mouth cavity, followed by a second step during which this small volume comprising the aerosol comprising the desired amount of nicotine is further diluted by fresh air and drawn deeper into the lungs. Both steps are controlled by the consumer. During the first inhalation step the consumer may determine the amount of nicotine to be inhaled. During the second step, the consumer may determine the volume for diluting the first volume to be drawn deeper into the lungs, maximizing the concentration of active agent delivered to the airway epithelial surface. This smoking mechanism is sometimes called "puff-inhale-exhale".

The dry powder utilized with the dry powder inhaler of the invention may eliminate or substantially reduce any exhalation of pharmaceutically active particles during the "exhale" phase. Preferably nearly all, or at least about 99% or at least about 95% or at least 90% of the pharmaceutically active particle has a particle size that is delivered to the lungs but are not small enough to be exhaled by tidal breathing. This pharmaceutically active particle size may be in a range from about 0.75 micrometers to about 5 micrometers, or from 0.8 micrometers to about 3 micrometers, or from 0.8 micrometers to about 2 micrometers.

All scientific and technical terms used herein have meanings commonly used in the art unless otherwise specified. The definitions provided herein are to facilitate understanding of certain terms used frequently herein.

The terms "upstream" and "downstream" refer to relative positions of elements of the inhaler described in relation to the direction of inhalation air flow as it is drawn through the body of the inhaler from a distal end portion or air inlet region to the mouthpiece portion.

As used herein, the singular forms "a", "an", and "the" encompass embodiments having plural referents, unless the content clearly dictates otherwise.

As used herein, "or" is generally employed in its sense including "and/or" unless the content clearly dictates otherwise. The term "and/or" means one or all of the listed elements or a combination of any two or more of the listed elements.

As used herein, "have", "having", "include", "including", "comprise", "comprising" or the like are used in their open-ended sense, and generally mean "including, but not limited to". It

will be understood that “consisting essentially of”, “consisting of”, and the like are subsumed in “comprising,” and the like.

The words “preferred” and “preferably” refer to embodiments of the invention that may afford certain benefits, under certain circumstances. However, other embodiments may also be preferred, under the same or other circumstances. Furthermore, the recitation of one or more preferred embodiments does not imply that other embodiments are not useful and is not intended to exclude other embodiments from the scope of the disclosure, including the claims.

FIG. 1 is a perspective view of an illustrative inhaler article.

FIG. 2 is a cross-sectional schematic diagram of the illustrative inhaler article of **FIG. 1** along the longitudinal axis.

FIG. 3 is a cross-sectional schematic diagram of an illustrative air inlet region along the axial axis.

FIG. 4 cross-sectional schematic diagram of an illustrative apertured porous support member along the axial axis.

FIG. 5 cross-sectional schematic diagram of another illustrative apertured porous support member along the axial axis.

FIG. 6 cross-sectional schematic diagram of another illustrative apertured porous support member along the axial axis.

FIG. 7 cross-sectional schematic diagram of another illustrative apertured porous support member along the axial axis.

FIG. 8 cross-sectional schematic diagram of another illustrative apertured porous support member along the axial axis.

FIG. 9 side elevation schematic diagram of an illustrative apertured porous support member along the longitudinal axis.

The schematic drawings are not necessarily to scale and are presented for purposes of illustration and not limitation. The drawings depict one or more aspects described in this

disclosure. However, it will be understood that other aspects not depicted in the drawing fall within the scope and spirit of this disclosure.

FIG. 1 and **FIG. 2** illustrate an exemplary inhaler article **100**. **FIG. 2** is a cross-sectional schematic diagram of the illustrative inhaler article **100** of **FIG. 1** along the longitudinal axis L_A . **FIG. 3** is a cross-sectional schematic diagram of the illustrative air inlet region or vortex tunnel **150** along the longitudinal axis L_A . The inhaler article **100** includes a body **110** extending along a longitudinal axis L_A from a mouthpiece end **112** to a distal end **114** and a capsule cavity **116** defined within the body **110**.

A mouthpiece air channel **111** extends from the capsule cavity **116** to the mouthpiece end **112**. An endpiece element **120** is disposed within the distal end **114** and extends to a vortex tunnel **150**. The endpiece element **120** is configured to restrict or prevent airflow through the endpiece element **120**. In this embodiment, the endpiece element **120** is formed of a body of cellulose acetate tow, having a high resistance to draw (RTD) of at least 100 mm water per millimeter.

The air inlet region or vortex tunnel **150** is disposed within the body **110** and extends to the capsule cavity **116**. The vortex tunnel **150** has an inner diameter D_1 defined by an inner surface **152** and an outer diameter D_2 defined by an outer surface **151**. The inner diameter D_1 defined by an inner surface **152** forms an air passageway **155** in the form of an open cylinder. The vortex tunnel **150** may include two air inlets or air channels **113** extending from the vortex tunnel **150** outer surface **151** to the air passageway **155**. The vortex tunnel **150** includes two air inlets **113** in communication with the air passageway **155**, at opposite sides of the inhaler article **100**. The two opposing air inlets **113** extend substantially linearly between the outer surface **151** of the vortex tunnel **150** and the inner surface **152**, to the air passage **155** at a tangent to the inner D_1 diameter of the open cylinder **155**. The openings of the two opposing air inlets **113** at the inner surface **152** are not aligned, and in particular, in this embodiment the two opposing air inlets **113** extend in substantially parallel directions, along axis that extend on opposite sides of the central longitudinal axis L_A of the vortex tunnel **150** and the inhaler article **100**. Providing two opposing air inlets **113** at a tangent to the inner diameter D_1 of the open cylinder **155** induces a swirling or vortex air flow pattern within the capsule cavity **116** of the inhaler body **110**.

The air inlet region or vortex tunnel **150** and the porous support element **140** bound the capsule cavity **116**. A capsule **130** may be disposed within the cavity **116**. The capsule **130**

contains particles comprising pharmaceutically active particles, such as nicotine. The air inlet region or vortex tunnel **150** and the porous support element **140** cooperate to contain the capsule **130** longitudinally within the capsule cavity **116**. The mouthpiece end **112** is illustrated having a recessed end where the body **110** bounds an open space at the mouthpiece end **112**.
5 Alternatively the porous support element **140** can extend to the mouthpiece end **112** to fill the entire mouthpiece end **112**. The capsule **130** has an axis of rotation in the capsule cavity is coextensive with the longitudinal axis L_A .

FIG. 4 cross-sectional schematic diagram of an illustrative apertured porous support member **140** along the axial axis. **FIG. 5** cross-sectional schematic diagram of another illustrative apertured porous support member **140** along the axial axis. **FIG. 6** cross-sectional schematic diagram of another illustrative apertured porous support member **140** along the axial axis. **FIG. 7** cross-sectional schematic diagram of another illustrative apertured porous support member **140** along the axial axis. **FIG. 8** cross-sectional schematic diagram of another illustrative apertured porous support member **140** along the axial axis. **FIG. 9** side elevation schematic diagram of an illustrative apertured porous support member **140** along the longitudinal axis L_A .
10
15

FIG. 4 illustrates a single circular aperture **142** that is co-incident with the longitudinal axis L_A of the porous support member **140**. The porous material **141** defines the single aperture **142**. The single aperture **142** has a diameter that is less than the diameter of the capsule contained within the capsule cavity.
20

FIG. 5 illustrates a pig nose aperture configuration of the porous support member **140**. This configuration defines two circular apertures **142**. The porous material **141** defines both apertures **142**.

FIG. 6 illustrates three intersecting triangles configuration of the porous support member **140**. This configuration defines three triangular apertures **142** that intersect at a vertex. The porous material **141** defines all three apertures **142**.
25

FIG. 7 illustrates six semi-circular apertures **142** spaced about the outer diameter of the porous support member **140**. The porous material **141** defines a portion of all six apertures **142**. No apertures are defined within the center portion of the porous support member **140**.

FIG. 8 illustrates six semi-circular apertures **142** spaced about the outer diameter of the porous support member **140**. The porous material **141** defines a portion of all six apertures **142**.
30

A center aperture **142** is defined within the center portion of the porous support member **140**. This porous support member **140** configuration may illustrate a preferred porous support member **140** configuration.

FIG. 9 illustrates a side elevation view of **FIG. 7** or **FIG. 8** where the six semi-circular apertures **142** spaced about the outer diameter of the porous support member **140** form a helical pattern along the longitudinal axis L_A of the porous support member **140**. In other aspects, the six semi-circular apertures **142** spaced about the outer diameter of the porous support member **140** form a linear pattern that is parallel with and along the longitudinal axis L_A of the porous support member **140**.

A separate piercing element (not shown) may be utilized by a consumer to pierce the endpiece element **120** and puncture the capsule **130** contained within the capsule cavity **116**. The piercing element may be withdrawn from the inhaler article **100** and endpiece element **120** before a user or consumer draws on the inhaler article **100**. A consumer may then draw on the inhaler article **100** to utilize the inhaler. Although the piercing element creates an opening in the endpiece element **120**, this is typically a small opening that may re-seal and does not significantly reduce or maintains the resistance to draw of the endpiece element **120**. In some embodiments, the endpiece element **120** reseals itself after the piercing element has been withdrawn from the endpiece element **120**.

CLAIMS:

1. An inhaler article comprising:
 - a body extending along a longitudinal axis from a mouthpiece end to a distal end;
 - 5 an endpiece element at the distal end;
 - a capsule cavity defined within the body and extending along the longitudinal axis a cavity length;
 - an air inlet region between the endpiece element and the capsule cavity, the air inlet region having an air inlet and an air passageway extending from the air inlet to the
 - 10 capsule cavity, the air passageway comprising an inner diameter less than an inner diameter of the capsule cavity;
 - a porous support element defining a downstream end of the capsule cavity, the porous support element formed of a porous material, the porous support element extending along a longitudinal axis a length, the porous support element comprises one or
 - 15 more apertures extending the length of the porous support element;
 - a mouthpiece air channel extending from the capsule cavity, through the porous element to the mouthpiece end.

2. The inhaler article according to claim 1, wherein the porous support element apertures
- 20 form helical features along the length of the support element.

3. The inhaler article according to claim 1 or 2, wherein the porous support element is formed of a polylactic acid material or cellulose acetate material.

- 25 4. The inhaler article according to any preceding claim, wherein the porous support element comprises two apertures, or three apertures, or four apertures, or five apertures, or six apertures, or seven apertures.

5. The inhaler article according to any preceding claim, wherein the porous support
- 30 element comprises the two or more apertures along an outer diameter of the porous support element.

6. The inhaler article according to any preceding claim, wherein the porous support element has a centre region co-incident with the longitudinal axis and the centre region includes an aperture.
- 5
7. The inhaler article according to any one of claims 1 to 5, wherein the porous support element has a centre region co-incident with the longitudinal axis and the centre region does not include an aperture.
- 10 8. The inhaler article according to any one of claims 1 to 6, wherein the porous support element has a centre region co-incident with the longitudinal axis and the centre region includes an aperture and four or more apertures along an outer diameter of the porous support element.
- 15 9. The inhaler article according to any one of claims 4 to 5, wherein the two or more apertures are equally spaced from each other along an outer diameter of the porous support element.
- 20 10. The inhaler article according to any preceding claim, wherein the one or more apertures define at least about 40%, or in a range from about 15% to about 60% of a circular cross-sectional surface area of the porous support element.
11. The inhaler article according to any preceding claim, wherein the air inlet region includes a vortex tunnel that induces a vortex of inhalation airflow into the capsule cavity.
- 25 12. An inhaler system comprising, the inhaler article according to any one of the preceding claims, and a capsule disposed within the capsule cavity of the inhaler article, the capsule containing pharmaceutically active particles, the pharmaceutically active particles having a mass median aerodynamic diameter of about 5 micrometres or less, or in a range from about

0.5 micrometres to about 4 micrometres, or in a range from about 1 micrometres to about 3 micrometres.

13. The system according to claim 12, wherein the capsule contains pharmaceutically active particles comprising nicotine.

14. The system according to claim 12 or claim 13, wherein the capsule further contains a second population of flavour particles having a mass median aerodynamic diameter of about 20 micrometres or greater, or about 50 micrometres or greater, or in a range from about 50 to about 200 micrometres, or from about 50 to about 150 micrometres.

15. The system according to any one of claims 12 to 14, wherein the system further comprises a piercing element removably engageable with the inhaler article to activate the capsule and wherein the endpiece element is configured to be pierced by the piercing element when activating the capsule.

16. The inhaler article according to any preceding claim, wherein the inner diameter of the air passageway is about 2 mm to about 4.5 mm and is less than an inner diameter of the capsule cavity.

20

17. The inhaler article according to claim 11, wherein the vortex tunnel comprises an inner diameter that is less than an inner diameter of the capsule cavity.

18. The inhaler article according to claim 17, wherein the inner diameter of the vortex tunnel is about 2 mm to about 4.5 mm that is less than an inner diameter of the capsule cavity.

25

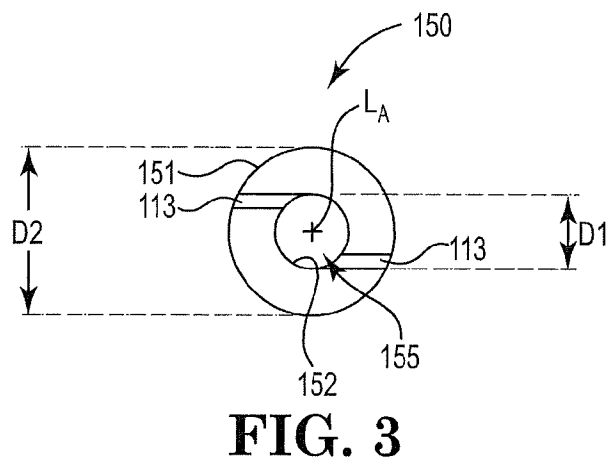
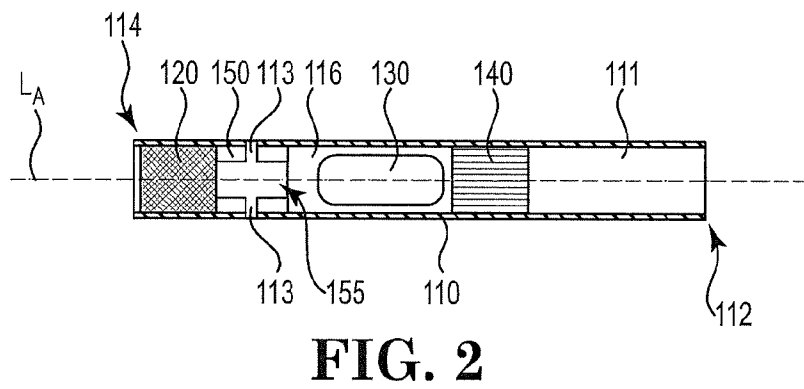
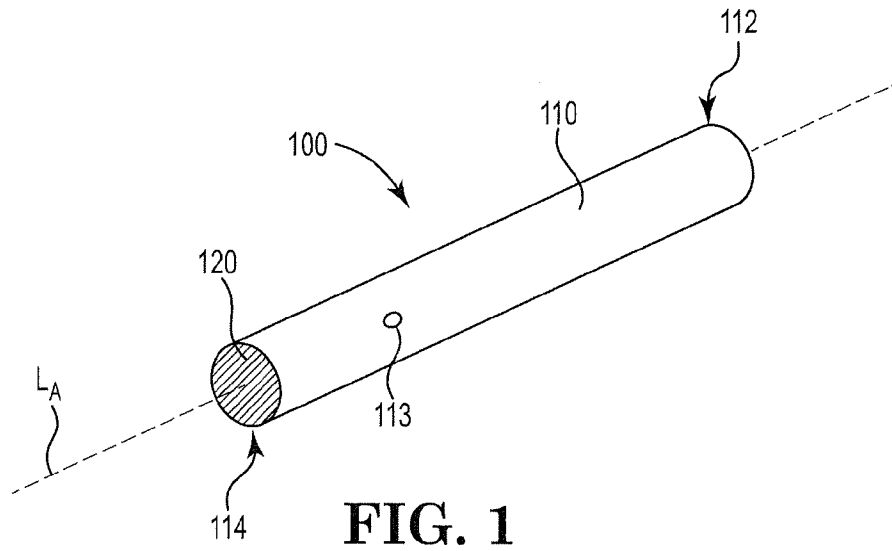

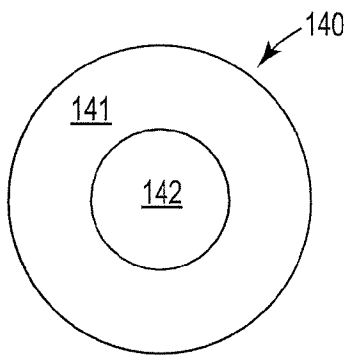

FIG. 4

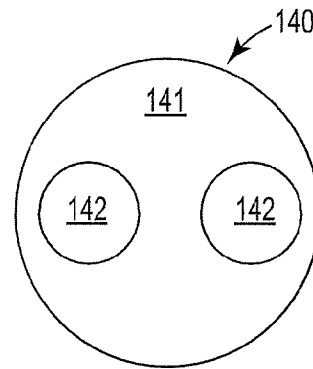

FIG. 5

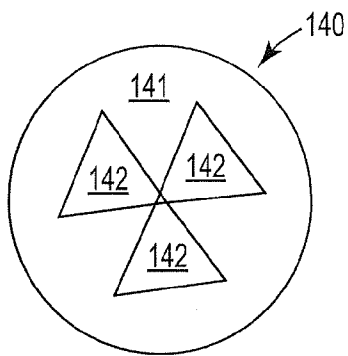

FIG. 6

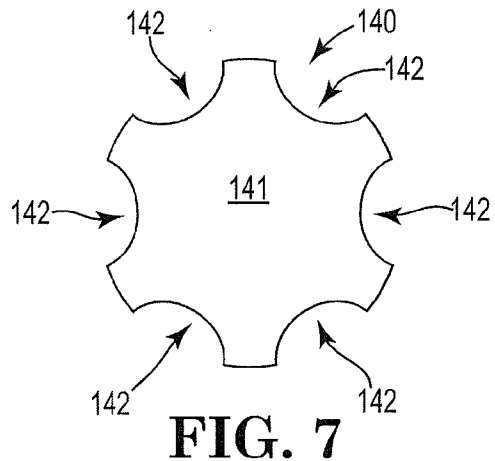

FIG. 7

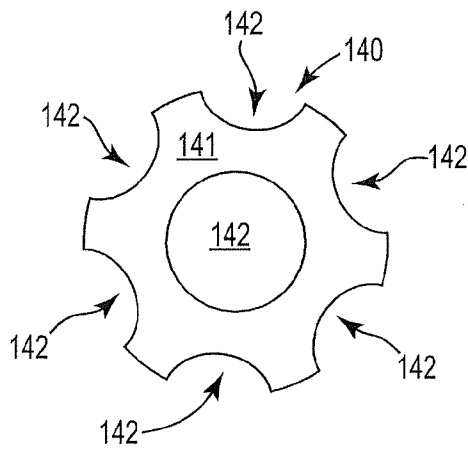

FIG. 8

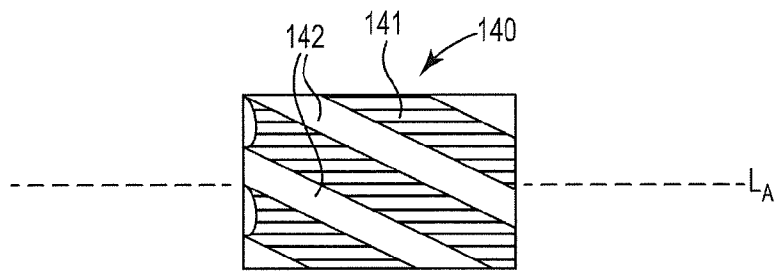

FIG. 9

INTERNATIONAL SEARCH REPORT

International application No
PCT/IB2019/052319

A. CLASSIFICATION OF SUBJECT MATTER
INV. A24F47/00 A61M15/06 A61M15/00
ADD.
According to International Patent Classification (IPC) or to both national classification and IPC

B. FIELDS SEARCHED
Minimum documentation searched (classification system followed by classification symbols)
A24F A61M
Documentation searched other than minimum documentation to the extent that such documents are included in the fields searched

Electronic data base consulted during the international search (name of data base and, where practicable, search terms used)
EPO-Internal, WPI Data

C. DOCUMENTS CONSIDERED TO BE RELEVANT		
Category*	Citation of document, with indication, where appropriate, of the relevant passages	Relevant to claim No.
Y	WO 2017/109626 A1 (PHILIP MORRIS PRODUCTS SA [CH]) 29 June 2017 (2017-06-29) figure 1 and 2 page 3, paragraph 31 - page 4, paragraph 25 page 5, line 3 - line 12 page 11, line 1 - line 4 page 12, line 14 - line 26 -----	1-15
Y	WO 2017/109678 A1 (PHILIP MORRIS PRODUCTS SA [CH]) 29 June 2017 (2017-06-29) figures 1-3 page 2, line 21 - page 3, line 5 page 4, line 27 - page 5, line 18 page 8, line 11 - line 21 page 12, line 18 - page 13, line 26 ----- -/--	1-15

Further documents are listed in the continuation of Box C.

See patent family annex.

* Special categories of cited documents :

"A" document defining the general state of the art which is not considered to be of particular relevance	"T" later document published after the international filing date or priority date and not in conflict with the application but cited to understand the principle or theory underlying the invention
"E" earlier application or patent but published on or after the international filing date	"X" document of particular relevance; the claimed invention cannot be considered novel or cannot be considered to involve an inventive step when the document is taken alone
"L" document which may throw doubts on priority claim(s) or which is cited to establish the publication date of another citation or other special reason (as specified)	"Y" document of particular relevance; the claimed invention cannot be considered to involve an inventive step when the document is combined with one or more other such documents, such combination being obvious to a person skilled in the art
"O" document referring to an oral disclosure, use, exhibition or other means	"&" document member of the same patent family
"P" document published prior to the international filing date but later than the priority date claimed	

Date of the actual completion of the international search 17 June 2019	Date of mailing of the international search report 28/06/2019
--	---

Name and mailing address of the ISA/ European Patent Office, P.B. 5818 Patentlaan 2 NL - 2280 HV Rijswijk Tel. (+31-70) 340-2040, Fax: (+31-70) 340-3016	Authorized officer Cecchini, Stefano
--	--

INTERNATIONAL SEARCH REPORT

International application No
PCT/IB2019/052319

C(Continuation). DOCUMENTS CONSIDERED TO BE RELEVANT		
Category*	Citation of document, with indication, where appropriate, of the relevant passages	Relevant to claim No.
Y	EP 0 387 222 A1 (DRACO AB [SE]) 12 September 1990 (1990-09-12) figure 1 and 2 column 4, line 2 - line 5 -----	2
Y	WO 2014/049494 A1 (PHILIP MORRIS PROD [CH]) 3 April 2014 (2014-04-03) figures 1-3 and 6 page 9, line 7 - line 8 -----	2
Y	US 4 069 819 A (VALENTINI LUIGI ET AL) 24 January 1978 (1978-01-24) passages of the description relating to figure 5; figure 5 column 2, line 15 - line 23 column 3, line 11 - line 16 -----	5,6,8,9, 11
A	WO 2018/007887 A1 (PHILIP MORRIS PRODUCTS SA [CH]) 11 January 2018 (2018-01-11) the whole document -----	1-18
A	EP 0 388 621 A1 (PHIDEA SRL [IT]) 26 September 1990 (1990-09-26) the whole document -----	1-18
A	WO 2004/091705 A1 (NEKTAR THERAPEUTICS [US]; DUNKLEY MIKE [GB] ET AL.) 28 October 2004 (2004-10-28) the whole document -----	1-18

INTERNATIONAL SEARCH REPORT

Information on patent family members

International application No

PCT/IB2019/052319

Patent document cited in search report	Publication date	Patent family member(s)	Publication date	
WO 2017109626	A1	29-06-2017	AU 2016379094 A1	21-06-2018
			BR 112018011496 A2	04-12-2018
			CA 3008211 A1	29-06-2017
			CN 108463262 A	28-08-2018
			EP 3393560 A1	31-10-2018
			JP 2019506914 A	14-03-2019
			KR 20180097534 A	31-08-2018
			PH 12018501143 A1	21-01-2019
			SG 11201805072P A	30-07-2018
			US 2018369517 A1	27-12-2018
			WO 2017109626 A1	29-06-2017
WO 2017109678	A1	29-06-2017	AU 2016376033 A1	28-06-2018
			BR 112018010830 A2	27-11-2018
			CA 3008996 A1	29-06-2017
			CN 108430551 A	21-08-2018
			EP 3393565 A1	31-10-2018
			JP 2019508015 A	28-03-2019
			KR 20180096611 A	29-08-2018
			PH 12018501199 A1	28-01-2019
			SG 11201805204W A	30-07-2018
			US 2019001084 A1	03-01-2019
			WO 2017109678 A1	29-06-2017
EP 0387222	A1	12-09-1990	AT 91911 T	15-08-1993
			AU 613264 B2	25-07-1991
			CA 2028830 A1	08-09-1990
			DE 69002353 D1	02-09-1993
			DE 69002353 T2	02-12-1993
			DK 0387222 T3	30-08-1993
			EP 0387222 A1	12-09-1990
			ES 2042267 T3	01-12-1993
			IE 64129 B1	12-07-1995
			JP 2927541 B2	28-07-1999
			JP H03504457 A	03-10-1991
			KR 0135309 B1	23-04-1998
			NO 175289 B	20-06-1994
			PT 93347 A	07-11-1990
			SE 466684 B	23-03-1992
			US 5331953 A	26-07-1994
			WO 9010470 A1	20-09-1990
WO 2014049494	A1	03-04-2014	CN 104780794 A	15-07-2015
			EP 2900093 A1	05-08-2015
			JP 2015530106 A	15-10-2015
			JP 2018174938 A	15-11-2018
			KR 20150064731 A	11-06-2015
			RU 2015115911 A	20-11-2016
			SG 11201502459X A	29-04-2015
			UA 116451 C2	26-03-2018
			US 2015257439 A1	17-09-2015
			WO 2014049494 A1	03-04-2014
US 4069819	A	24-01-1978	NONE	
WO 2018007887	A1	11-01-2018	AU 2017293424 A1	08-11-2018
			CA 3022612 A1	11-01-2018
			CN 109219462 A	15-01-2019

INTERNATIONAL SEARCH REPORT

Information on patent family members

International application No PCT/IB2019/052319

Patent document cited in search report		Publication date		Patent family member(s)	Publication date
				EP 3481472 A1	15-05-2019
				KR 20190026656 A	13-03-2019
				SG 11201811746T A	30-01-2019
				WO 2018007887 A1	11-01-2018
EP 0388621	A1	26-09-1990		AT 79284 T	15-08-1992
				DE 69000249 D1	17-09-1992
				DE 69000249 T2	11-03-1993
				DK 0388621 T3	02-11-1992
				EP 0388621 A1	26-09-1990
				ES 2034781 T3	01-04-1993
				IT 1228459 B	19-06-1991
				US 4995385 A	26-02-1991
WO 2004091705	A1	28-10-2004		AT 549051 T	15-03-2012
				AU 2004229446 A1	28-10-2004
				CA 2520032 A1	28-10-2004
				CY 1113859 T1	27-07-2016
				DK 1610850 T3	25-06-2012
				EP 1610850 A1	04-01-2006
				ES 2383367 T3	20-06-2012
				JP 4943838 B2	30-05-2012
				JP 2006522663 A	05-10-2006
				KR 20050114720 A	06-12-2005
				MX PA05010842 A	30-03-2006
				PL 1610850 T3	30-11-2012
				PT 1610850 E	15-06-2012
				SI 1610850 T1	28-09-2012
				US 2005150492 A1	14-07-2005
				US 2009260623 A1	22-10-2009
				WO 2004091705 A1	28-10-2004