



US00D972722S

(12) **United States Design Patent** (10) **Patent No.:** **US D972,722 S**  
**Gray** (45) **Date of Patent:** **\*\* Dec. 13, 2022**

(54) **SLIDE CLAMP**

OTHER PUBLICATIONS

(71) Applicant: **DEKA Products Limited Partnership**,  
Manchester, NH (US)

U.S. Appl. No. 29/651,489, filed Aug. 16, 2018, Application Pub-  
lication USD0917045S.

(Continued)

(72) Inventor: **Larry B. Gray**, Merrimack, NH (US)

*Primary Examiner* — Nathan M Johnston

(73) Assignee: **DEKA Products Limited Partnership**,  
Manchester, NH (US)

(74) *Attorney, Agent, or Firm* — James D. Wyninegar, Jr.

(\*\*) Term: **15 Years**

(57) **CLAIM**

(21) Appl. No.: **29/817,071**

The ornamental design for a slide clamp, as shown and  
described.

(22) Filed: **Nov. 29, 2021**

**Related U.S. Application Data**

(62) Division of application No. 29/774,892, filed on Mar.  
19, 2021, now Pat. No. Des. 937,413, which is a  
(Continued)

**DESCRIPTION**

(51) **LOC (13) Cl.** ..... **24-02**

FIG. 1 is a front, top, and right-side perspective view of the  
slide clamp, which may be used to occlude a fluid line within  
the slot, showing our new design;

(52) **U.S. Cl.**

FIG. 2 is a front elevation view thereof;

USPC ..... **D24/129**; D24/143

FIG. 3 is a back elevational view thereof;

(58) **Field of Classification Search**

FIG. 4 is a right-side elevational view thereof;

USPC ..... D8/71-74, 394-399, 59; 248/63, 72,  
248/74.1, 689, 124.2; 81/487, 385, 386,

FIG. 5 is a left-side elevational view thereof;

(Continued)

FIG. 6 is a top plan view thereof;

(56) **References Cited**

FIG. 7 is a bottom plan view thereof;

**U.S. PATENT DOCUMENTS**

FIG. 8 is a front, top, and right-side perspective view of  
another embodiment of a slide clamp, showing our new  
design;

2,245,774 A 6/1941 Gregorek  
4,248,401 A \* 2/1981 Mittleman ..... A61M 39/287  
24/130

FIG. 9 is a front elevation view thereof;

(Continued)

FIG. 10 is a back elevational view thereof;

**FOREIGN PATENT DOCUMENTS**

EP 1778338 B1 11/2011  
WO WO2013095459 A9 6/2013

FIG. 11 is a right-side elevational view thereof;

(Continued)

FIG. 12 is a left-side elevational view thereof;

FIG. 13 is a top plan view thereof; and,

FIG. 14 is a bottom plan view thereof.

The ornamental design which is claimed is shown in solid  
lines in the drawings. The broken lines show portions of the  
slide clamp that form no part of the claimed design.

**1 Claim, 14 Drawing Sheets**

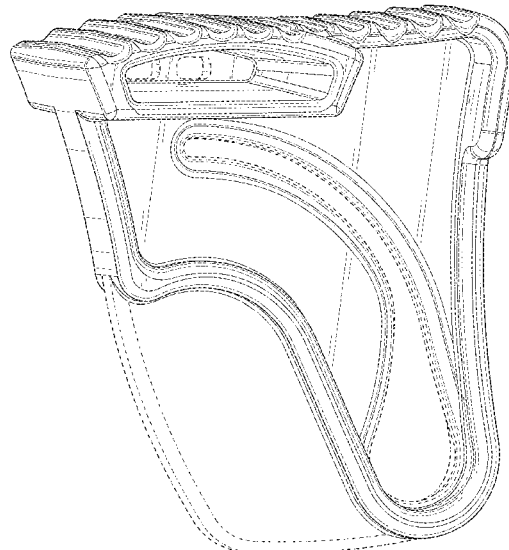

**Related U.S. Application Data**

division of application No. 29/651,489, filed on Aug. 16, 2018, now Pat. No. Des. 917,045.

(58) **Field of Classification Search**

USPC ..... 81/388-390; 269/3, 4, 6, 143, 165, 240, 269/243, 246-249, 254 R, 147-149; 29/256, 257, 276; 408/103, 104-109; D24/128, 133, 143, 129, 135  
 CPC .... A61M 39/287; A61M 39/28; A61M 39/00; Y10T 24/44906; Y10T 24/3918  
 See application file for complete search history.

(56) **References Cited**

U.S. PATENT DOCUMENTS

4,307,869 A \* 12/1981 Mittleman ..... A61M 39/287  
 128/205.17  
 4,434,963 A \* 3/1984 Russell ..... A61M 39/287  
 251/7  
 4,714,463 A 12/1987 Archibald et al.  
 5,026,019 A 6/1991 Biekart et al.  
 5,290,239 A 3/1994 Classey et al.  
 5,437,635 A 8/1995 Fields et al.  
 5,437,642 A 8/1995 Thill et al.  
 5,480,386 A 1/1996 Brohy et al.  
 5,518,378 A 5/1996 Neftel et al.  
 5,741,125 A 4/1998 Neftel et al.  
 5,827,262 A 10/1998 Neftel et al.  
 5,853,398 A 12/1998 Lal et al.  
 5,968,014 A 10/1999 Neftel et al.  
 6,117,115 A 9/2000 Hill et al.  
 6,261,262 B1 7/2001 Briggs et al.  
 6,364,279 B1 4/2002 Neftel et al.  
 6,776,152 B2 8/2004 Gray et al.  
 6,840,492 B1 1/2005 Boyne-Aitken  
 7,124,996 B2 10/2006 Clarke et al.  
 D556,940 S 12/2007 Gajewski et al.  
 7,303,175 B2 12/2007 Smith et al.  
 7,329,248 B2 2/2008 Raulerson et al.  
 7,350,761 B1 4/2008 Stuart et al.  
 7,419,133 B2 9/2008 Clarke et al.  
 7,530,968 B2 5/2009 Gonnelli et al.  
 7,648,627 B2 1/2010 Beden et al.  
 7,806,887 B2 10/2010 Raulerson et al.  
 7,934,912 B2 5/2011 Voltenburg, Jr. et al.  
 8,062,008 B2 11/2011 Voltenburg, Jr. et al.  
 8,083,503 B2 12/2011 Voltenburg, Jr. et al.  
 8,109,898 B2 2/2012 Wolff  
 8,142,653 B2 3/2012 Beden et al.  
 8,257,066 B2 9/2012 Kasai et al.  
 8,328,763 B2 12/2012 Traversaz  
 8,361,053 B2 1/2013 Gonnelli et al.  
 8,366,921 B2 2/2013 Beden et al.  
 8,377,293 B2 2/2013 Beden et al.  
 8,435,408 B2 5/2013 Beden et al.  
 8,469,933 B2 6/2013 Zhang et al.  
 8,679,075 B2 3/2014 Lurvey et al.  
 8,721,883 B2 5/2014 Lauer  
 8,821,443 B2 9/2014 Levesque et al.  
 9,017,297 B2 4/2015 Travis et al.  
 D728,779 S 5/2015 Sabin et al.  
 9,028,456 B2 5/2015 Kasai et al.  
 D735,319 S 7/2015 Sabin et al.  
 D736,370 S 8/2015 Sabin et al.  
 9,101,709 B2 8/2015 Beden et al.  
 9,151,646 B2 10/2015 Kamen et al.  
 D745,661 S 12/2015 Collins et al.  
 D749,206 S 2/2016 Johnson et al.  
 D751,689 S 3/2016 Peret et al.  
 D751,690 S 3/2016 Peret et al.  
 D752,209 S 3/2016 Peret et al.  
 9,272,129 B2 3/2016 Howlett et al.  
 9,283,370 B2 3/2016 Travis et al.  
 9,295,778 B2 3/2016 Kamen et al.  
 D754,065 S 4/2016 Gray et al.

D756,386 S 5/2016 Kendler et al.  
 D758,399 S 6/2016 Kendler et al.  
 D760,288 S 6/2016 Kendler et al.  
 D760,289 S 6/2016 Kendler et al.  
 9,364,394 B2 6/2016 Demers et al.  
 9,372,486 B2 6/2016 Peret et al.  
 9,377,015 B2 6/2016 Traversaz et al.  
 D760,782 S 7/2016 Kendler et al.  
 D760,888 S 7/2016 Gill et al.  
 9,400,873 B2 7/2016 Kamen et al.  
 9,408,966 B2 8/2016 Kamen  
 D767,756 S 9/2016 Sabin  
 9,435,455 B2 9/2016 Peret et al.  
 D768,716 S 10/2016 Kendler et al.  
 9,465,919 B2 10/2016 Kamen et al.  
 9,488,200 B2 11/2016 Kamen et al.  
 D774,645 S 12/2016 Gill et al.  
 9,518,958 B2 12/2016 Wilt et al.  
 9,636,455 B2 5/2017 Kamen et al.  
 9,649,436 B2 5/2017 Capone et al.  
 D789,516 S 6/2017 Gill et al.  
 9,675,756 B2 6/2017 Kamen et al.  
 9,677,555 B2 6/2017 Kamen et al.  
 9,687,417 B2 6/2017 Demers et al.  
 D792,963 S 7/2017 Gill  
 9,700,672 B2 7/2017 Capone et al.  
 D795,424 S 8/2017 Sloss  
 D795,805 S 8/2017 Gray et al.  
 9,719,964 B2 8/2017 Blumberg, Jr.  
 9,724,465 B2 8/2017 Peret et al.  
 9,724,466 B2 8/2017 Peret et al.  
 9,724,467 B2 8/2017 Peret et al.  
 9,730,731 B2 8/2017 Langenfeld et al.  
 9,744,300 B2 8/2017 Kamen et al.  
 9,746,093 B2 8/2017 Peret et al.  
 9,746,094 B2 8/2017 Peret et al.  
 9,759,343 B2 9/2017 Peret et al.  
 9,759,369 B2 9/2017 Gray et al.  
 9,772,044 B2 9/2017 Peret et al.  
 D799,025 S 10/2017 Johnson et al.  
 D801,519 S 10/2017 Sabin et al.  
 9,789,247 B2 10/2017 Kamen et al.  
 D802,118 S 11/2017 Peret et al.  
 D803,386 S 11/2017 Sabin et al.  
 D803,387 S 11/2017 Bodwell et al.  
 D804,017 S 11/2017 Sabin  
 9,808,572 B2 11/2017 Kamen et al.  
 D805,183 S 12/2017 Sabin et al.  
 9,856,990 B2 1/2018 Peret et al.  
 D813,376 S 3/2018 Peret et al.  
 D814,021 S 3/2018 Sabin  
 D815,730 S 4/2018 Collins et al.  
 D816,685 S 5/2018 Kendler et al.  
 D816,829 S 5/2018 Peret et al.  
 D817,479 S 5/2018 Sabin et al.  
 D817,480 S 5/2018 Sabin et al.  
 9,968,730 B2 5/2018 Blumberg, Jr. et al.  
 9,976,665 B2 5/2018 Peret et al.  
 10,044,791 B2 8/2018 Kamen et al.  
 10,082,241 B2 9/2018 Janway et al.  
 10,088,346 B2 10/2018 Kane et al.  
 10,108,785 B2 10/2018 Kamen et al.  
 10,113,660 B2 10/2018 Peret et al.  
 10,126,267 B2 11/2018 Blumberg, Jr.  
 10,185,812 B2 1/2019 Kamen et al.  
 10,202,970 B2 2/2019 Kamen et al.  
 10,202,971 B2 2/2019 Kamen et al.  
 10,220,135 B2 3/2019 Kamen et al.  
 10,228,683 B2 3/2019 Peret et al.  
 10,242,159 B2 3/2019 Kamen et al.  
 10,245,374 B2 4/2019 Kamen et al.  
 10,265,463 B2 4/2019 Biasi et al.  
 10,288,057 B2 5/2019 Kamen et al.  
 10,316,834 B2 6/2019 Kamen et al.  
 D854,145 S 7/2019 Collins  
 10,380,321 B2 8/2019 Kamen et al.  
 10,391,241 B2 8/2019 Desch et al.  
 D860,437 S 9/2019 Collins  
 10,426,517 B2 10/2019 Langenfeld et al.

(56)	<b>References Cited</b>		2013/0131608 A1	5/2013	Davis et al.	
			2013/0177455 A1	7/2013	Kamen	
	U.S. PATENT DOCUMENTS		2013/0177476 A1*	7/2013	Hlavinka .....	F16L 3/12 422/28
10,436,342 B2	10/2019	Peret et al.	2013/0182381 A1	7/2013	Gray	
10,453,157 B2	10/2019	Kamen et al.	2013/0184676 A1	7/2013	Kamen	
10,468,132 B2	11/2019	Kamen et al.	2013/0188040 A1	7/2013	Kamen	
10,471,402 B2	11/2019	Demers et al.	2013/0191513 A1	7/2013	Kamen	
10,478,261 B2	11/2019	Demers et al.	2013/0197693 A1	8/2013	Kamen	
10,488,848 B2	11/2019	Peret et al.	2013/0204188 A1	8/2013	Kamen	
10,507,319 B2	12/2019	Haury et al.	2013/0253442 A1	9/2013	Travis et al.	
10,561,787 B2	2/2020	Kamen et al.	2013/0272773 A1	10/2013	Kamen	
10,563,681 B2	2/2020	Kamen et al.	2013/0281965 A1	10/2013	Kamen	
10,571,070 B2	2/2020	Gray et al.	2013/0310990 A1	11/2013	Peret et al.	
10,655,779 B2	5/2020	Janway et al.	2013/0317753 A1	11/2013	Kamen	
10,670,182 B2	6/2020	Janway et al.	2013/0317837 A1	11/2013	Ballantyne	
10,718,445 B2	7/2020	Yoo	2013/0336814 A1	12/2013	Kamen	
10,722,645 B2	7/2020	Kamen et al.	2013/0339049 A1	12/2013	Blumberg, Jr.	
10,739,759 B2	8/2020	Peret et al.	2013/0346108 A1	12/2013	Kamen	
10,753,353 B2	8/2020	Kamen et al.	2014/0165703 A1	6/2014	Wilt	
10,761,061 B2	9/2020	Wilt et al.	2014/0180711 A1	6/2014	Kamen	
10,839,953 B2	11/2020	Kamen et al.	2014/0188076 A1	7/2014	Kamen	
10,844,970 B2	11/2020	Peret et al.	2014/0188516 A1	7/2014	Kamen	
D905,848 S	12/2020	Sloss et al.	2014/0195639 A1	7/2014	Kamen	
10,857,293 B2	12/2020	Kamen et al.	2014/0227021 A1	8/2014	Kamen	
10,872,685 B2	12/2020	Blumberg, Jr. et al.	2014/0234144 A1	8/2014	Traversaz et al.	
10,876,868 B2	12/2020	Kane et al.	2014/0318639 A1	10/2014	Peret	
10,894,638 B2	1/2021	Peret et al.	2014/0343492 A1	11/2014	Kamen	
10,911,515 B2	2/2021	Biasi et al.	2015/0002667 A1	1/2015	Peret et al.	
D914,195 S	3/2021	Gray et al.	2015/0002668 A1	1/2015	Peret et al.	
D914,196 S	3/2021	Gray et al.	2015/0002677 A1	1/2015	Peret et al.	
D914,197 S	3/2021	Gray et al.	2015/0033823 A1	2/2015	Blumberg, Jr.	
D917,045 S	4/2021	Gray	2015/0040987 A1*	2/2015	Reichert .....	A61M 5/16813 137/1
D918,396 S	5/2021	Gray et al.				
10,994,074 B2	5/2021	Blumberg, Jr. et al.	2015/0154364 A1	6/2015	Biasi et al.	
11,024,409 B2	6/2021	Kamen et al.	2015/0157791 A1	6/2015	Desch et al.	
11,024,419 B2	6/2021	Kamen et al.	2015/0165105 A1	6/2015	Beden et al.	
11,109,934 B2	9/2021	Demers et al.	2015/0238228 A1	8/2015	Langenfeld et al.	
11,129,933 B2	9/2021	Kamen et al.	2015/0257974 A1	9/2015	Demers et al.	
D937,413 S	11/2021	Gray	2015/0314083 A1	11/2015	Blumberg, Jr. et al.	
11,164,672 B2	11/2021	Kamen et al.	2015/0332009 A1	11/2015	Kane et al.	
11,179,688 B2	11/2021	Demers et al.	2016/0000996 A1	1/2016	Faulhaber et al.	
11,210,611 B2	12/2021	Kamen et al.	2016/00055397 A1	2/2016	Peret et al.	
11,217,340 B2	1/2022	Desch et al.	2016/0055649 A1	2/2016	Peret et al.	
11,227,687 B2	1/2022	Kamen et al.	2016/0061641 A1	3/2016	Peret et al.	
D943,736 S	2/2022	Sloss et al.	2016/0063353 A1	3/2016	Peret et al.	
11,244,745 B2	2/2022	Kamen et al.	2016/0073063 A1	3/2016	Peret et al.	
11,295,846 B2	4/2022	Kamen et al.	2016/0084434 A1	3/2016	Janway et al.	
11,328,803 B2	5/2022	Kamen et al.	2016/0097382 A1	4/2016	Kamen et al.	
11,339,887 B2	5/2022	Peret et al.	2016/0131272 A1	5/2016	Yoo	
11,339,918 B2	5/2022	Gray et al.	2016/0151560 A1	6/2016	Toro et al.	
11,348,674 B2	5/2022	Kamen et al.	2016/0151561 A1	6/2016	Toro et al.	
2004/0186445 A1	9/2004	Raulerson et al.	2016/0151562 A1	6/2016	Magers et al.	
2005/0277890 A1*	12/2005	Stewart .....	2016/0151567 A1	6/2016	Howlett et al.	
		G16H 20/17 604/189	2016/0158437 A1	6/2016	Biasi et al.	
2006/0011873 A1*	1/2006	Clarke .....	2016/0179086 A1	6/2016	Peret et al.	
		F16K 7/066 251/4	2016/0184510 A1	6/2016	Kamen et al.	
2006/0129110 A1	6/2006	Smith et al.	2016/0203292 A1	7/2016	Kamen et al.	
2006/0224128 A1*	10/2006	Lurvey .....	2016/0262977 A1	9/2016	Demers et al.	
		A61M 5/14228 604/250	2016/0319850 A1	11/2016	Kamen et al.	
2007/0135794 A1	6/2007	Raulerson et al.	2016/0346056 A1	12/2016	Demers et al.	
2009/0204075 A1*	8/2009	Simpson .....	2016/0346484 A1	12/2016	Abal	
		A61M 5/162 604/151	2016/0362234 A1	12/2016	Peret et al.	
2009/0254034 A1	10/2009	Beck et al.	2017/0011202 A1	1/2017	Kamen et al.	
2010/0040481 A1	2/2010	Wolff	2017/0045478 A1	2/2017	Wilt et al.	
2011/0313789 A1	12/2011	Kamen et al.	2017/0136227 A1	5/2017	Davis et al.	
2012/0004624 A1*	1/2012	Brown .....	2017/0216516 A1	8/2017	Dale et al.	
		A61M 39/287 604/250	2017/0224909 A1	8/2017	Kamen et al.	
2012/0035581 A1*	2/2012	Travis .....	2017/0259230 A1	9/2017	Demers et al.	
		A61M 39/28 604/500	2017/0266378 A1	9/2017	Kamen et al.	
2012/0061310 A1	3/2012	Beden et al.	2017/0268497 A1	9/2017	Kamen et al.	
2012/0156097 A1	6/2012	Beden et al.	2017/0284968 A1	10/2017	Blumberg, Jr.	
2012/0181225 A1	7/2012	Weis	2017/0296745 A1	10/2017	Kamen et al.	
2012/0181226 A1	7/2012	Lauer	2017/0303969 A1	10/2017	Langenfeld et al.	
2012/0181231 A1	7/2012	Beden et al.	2017/0321841 A1	11/2017	Gray et al.	
2012/0185267 A1	7/2012	Kamen	2017/0333623 A1	11/2017	Kamen et al.	
2013/0118961 A1	5/2013	Beden et al.	2017/0335988 A1	11/2017	Peret et al.	
2013/0118970 A1	5/2013	Beden et al.	2018/0038501 A1	2/2018	Peret et al.	
			2018/0066648 A1	3/2018	Kamen et al.	

(56)

## References Cited

## U.S. PATENT DOCUMENTS

2018/0080605	A1	3/2018	Janway et al.
2018/0106246	A1	4/2018	Kamen et al.
2018/0128259	A1	5/2018	Kamen et al.
2018/0187782	A1	7/2018	Slaby et al.
2018/0221643	A1	8/2018	Hetchler et al.
2018/0224012	A1	8/2018	Peret et al.
2018/0228964	A1	8/2018	Blumberg, Jr. et al.
2018/0252359	A1	9/2018	Janway et al.
2018/0278676	A1	9/2018	Kamen et al.
2019/0009018	A1	1/2019	Kamen et al.
2019/0033104	A1	1/2019	Kane et al.
2019/0041362	A1	2/2019	Blumberg, Jr.
2019/0049029	A1	2/2019	Peret et al.
2019/0134298	A1	5/2019	Kamen et al.
2019/0139640	A1	5/2019	Kamen et al.
2019/0154026	A1	5/2019	Kamen et al.
2019/0170134	A1	6/2019	Kamen et al.
2019/0175821	A1	6/2019	Kamen et al.
2019/0179289	A1	6/2019	Peret et al.
2019/0189272	A1	6/2019	Kamen et al.
2019/0219047	A1	7/2019	Kamen et al.
2019/0249657	A1	8/2019	Kamen et al.
2019/0298913	A1	10/2019	Biasi et al.
2019/0316948	A1	10/2019	Karol et al.
2019/0328964	A1	10/2019	Desch et al.
2019/0341146	A1	11/2019	Kamen et al.
2019/0365421	A1	12/2019	Langenfeld et al.
2020/0025305	A1	1/2020	Peret et al.
2020/0051190	A1	2/2020	Kamen et al.
2020/0054823	A1	2/2020	Baier et al.
2020/0066388	A1	2/2020	Kamen et al.
2020/0070113	A1	3/2020	Demers et al.
2020/0078127	A1	3/2020	Demers et al.
2020/0171241	A1	6/2020	Kamen et al.
2020/0173469	A1	6/2020	Kamen et al.
2020/0182400	A1	6/2020	Gray et al.
2020/0278078	A1	9/2020	Janway et al.
2020/0292127	A1	9/2020	Janway et al.
2020/0347949	A1	11/2020	Yoo
2020/0371497	A1	11/2020	Peret et al.
2020/0386220	A1	12/2020	Kamen et al.
2020/0393414	A1	12/2020	Wilt et al.
2021/0023296	A1	1/2021	Langenfeld et al.
2021/0062929	A1	3/2021	Peret et al.
2021/0065867	A1	3/2021	Kamen et al.
2021/0085858	A1	3/2021	Kamen et al.
2021/0098102	A1	4/2021	Blumberg, Jr. et al.
2021/0116271	A1	4/2021	Kane et al.
2021/0125719	A1	4/2021	Peret et al.
2021/0252211	A1	8/2021	Shafferkoetter et al.
2021/0287790	A1	9/2021	Kamen et al.
2021/0304864	A1	9/2021	Kamen et al.
2021/0308366	A1	10/2021	Kamen et al.
2021/0365849	A1	11/2021	Kamen et al.
2021/0378777	A1	12/2021	Demers et al.
2022/0008649	A1	1/2022	Kamen et al.
2022/0044796	A1	2/2022	Kamen et al.
2022/0062541	A1	3/2022	Kamen et al.
2022/0122002	A1	4/2022	Kamen et al.
2022/0122710	A1	4/2022	Desch et al.
2022/0130536	A1	4/2022	Kamen et al.
2022/0143564	A1	5/2022	Demers et al.

## FOREIGN PATENT DOCUMENTS

WO	WO2013096713	A2	6/2013
WO	WO2013096718	A2	6/2013
WO	WO2013096722	A2	6/2013
WO	WO2013096909	A2	6/2013
WO	WO2013176770	A2	11/2013
WO	WO2013177357	A1	11/2013
WO	WO2014100557	A2	6/2014
WO	WO2014100571	A2	6/2014
WO	WO2014100658	A1	6/2014
WO	WO2014100687	A2	6/2014
WO	WO2014100736	A2	6/2014
WO	WO2014100744	A2	6/2014
WO	WO2014144557	A2	9/2014
WO	WO2015017275	A1	2/2015

## OTHER PUBLICATIONS

U.S. Appl. No. 29/702,135, filed Aug. 16, 2019.  
U.S. Appl. No. 29/774,892, filed Mar. 19, 2021, Application Publication USD0937413S.

\* cited by examiner

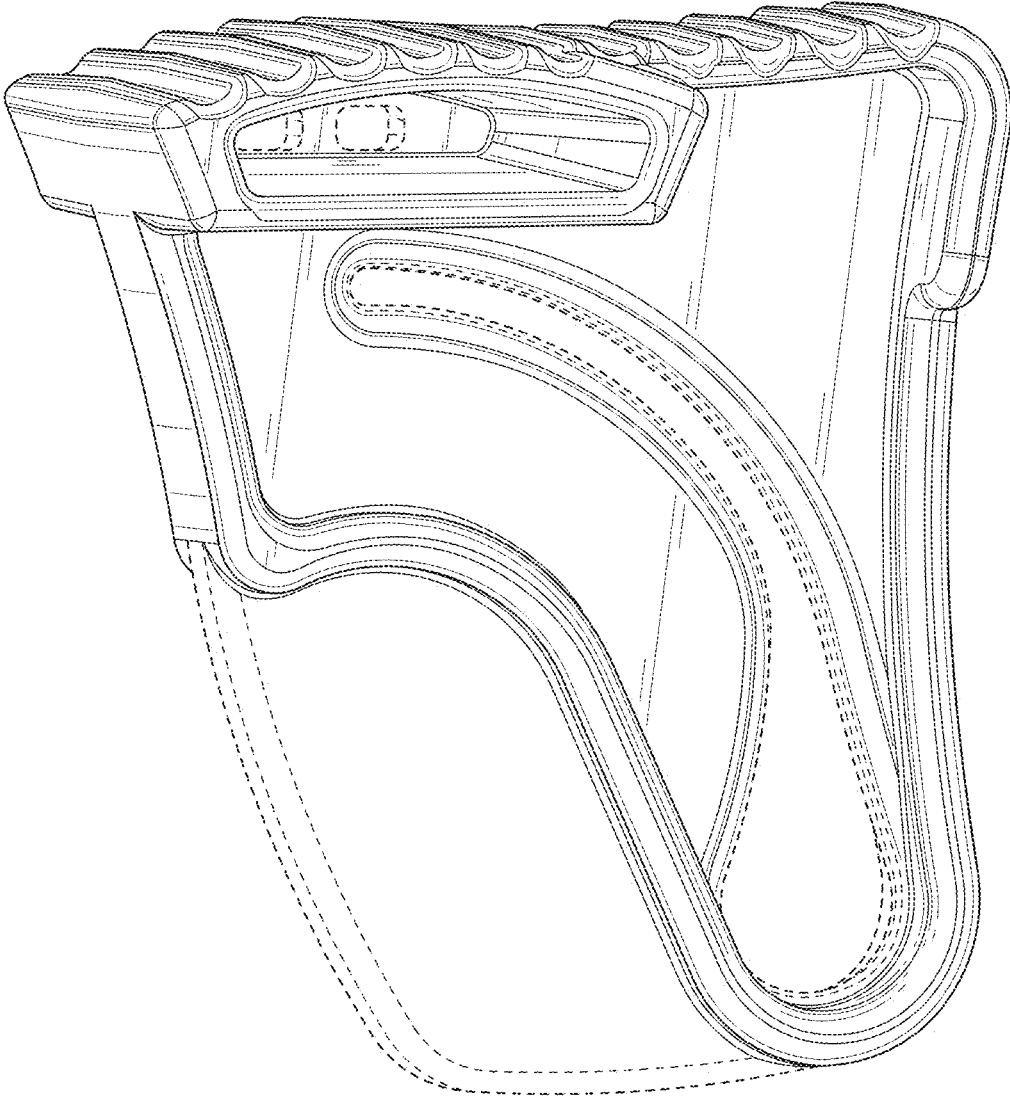

FIG. 1

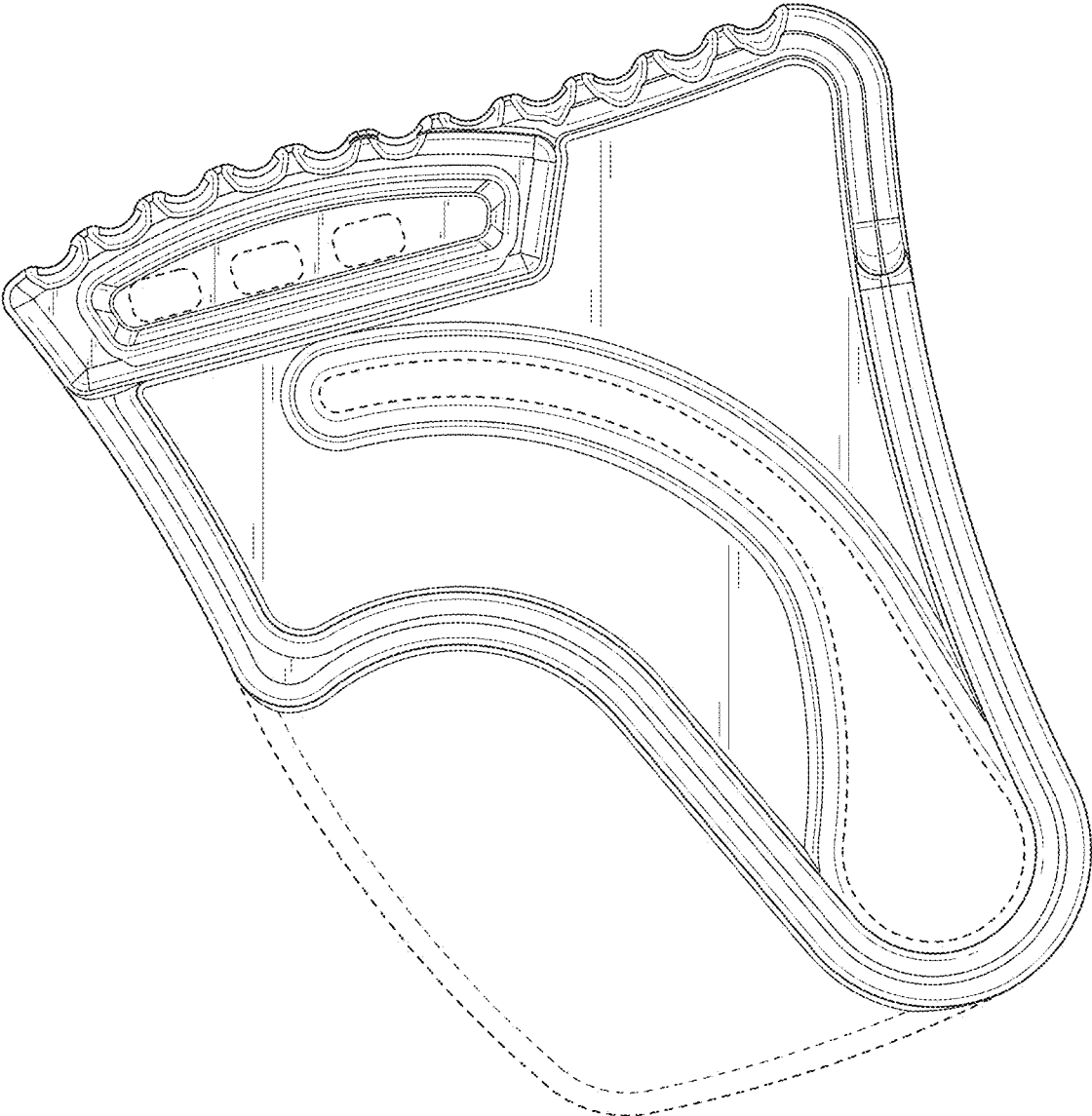

FIG. 2

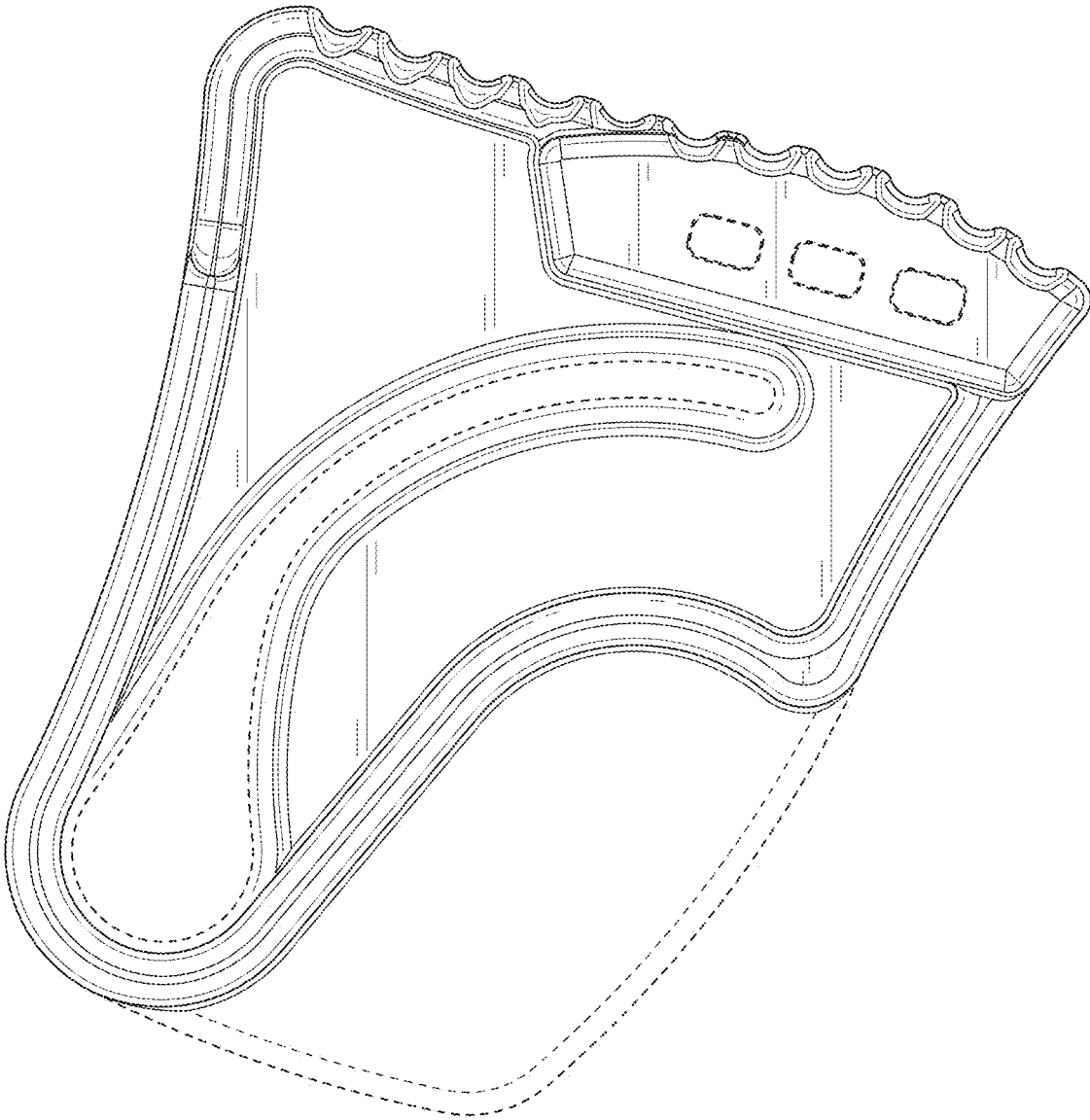

FIG. 3

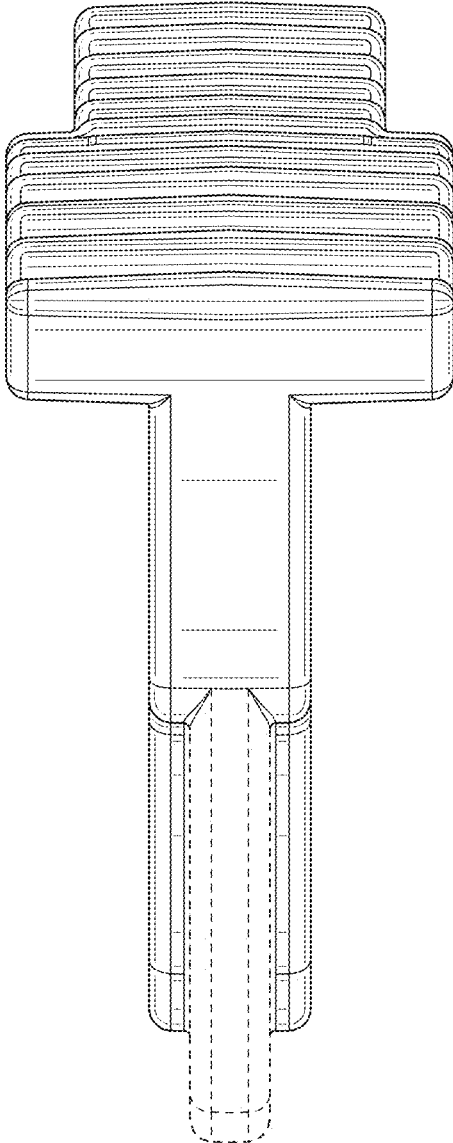

FIG. 4

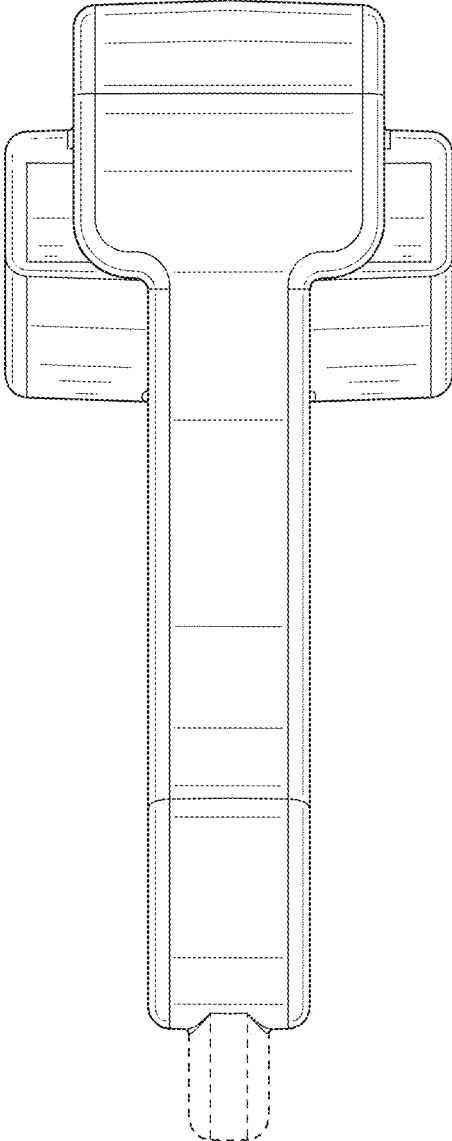

FIG. 5

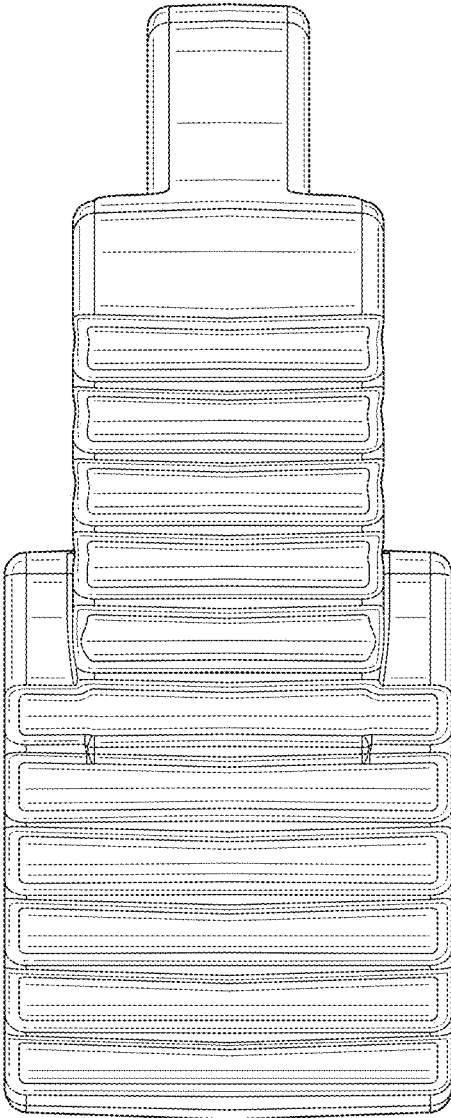

FIG. 6

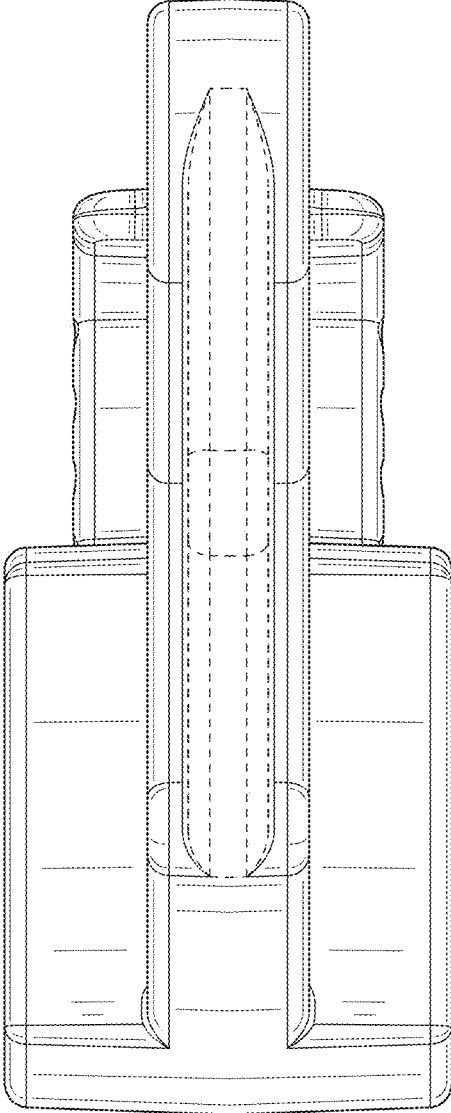

FIG. 7

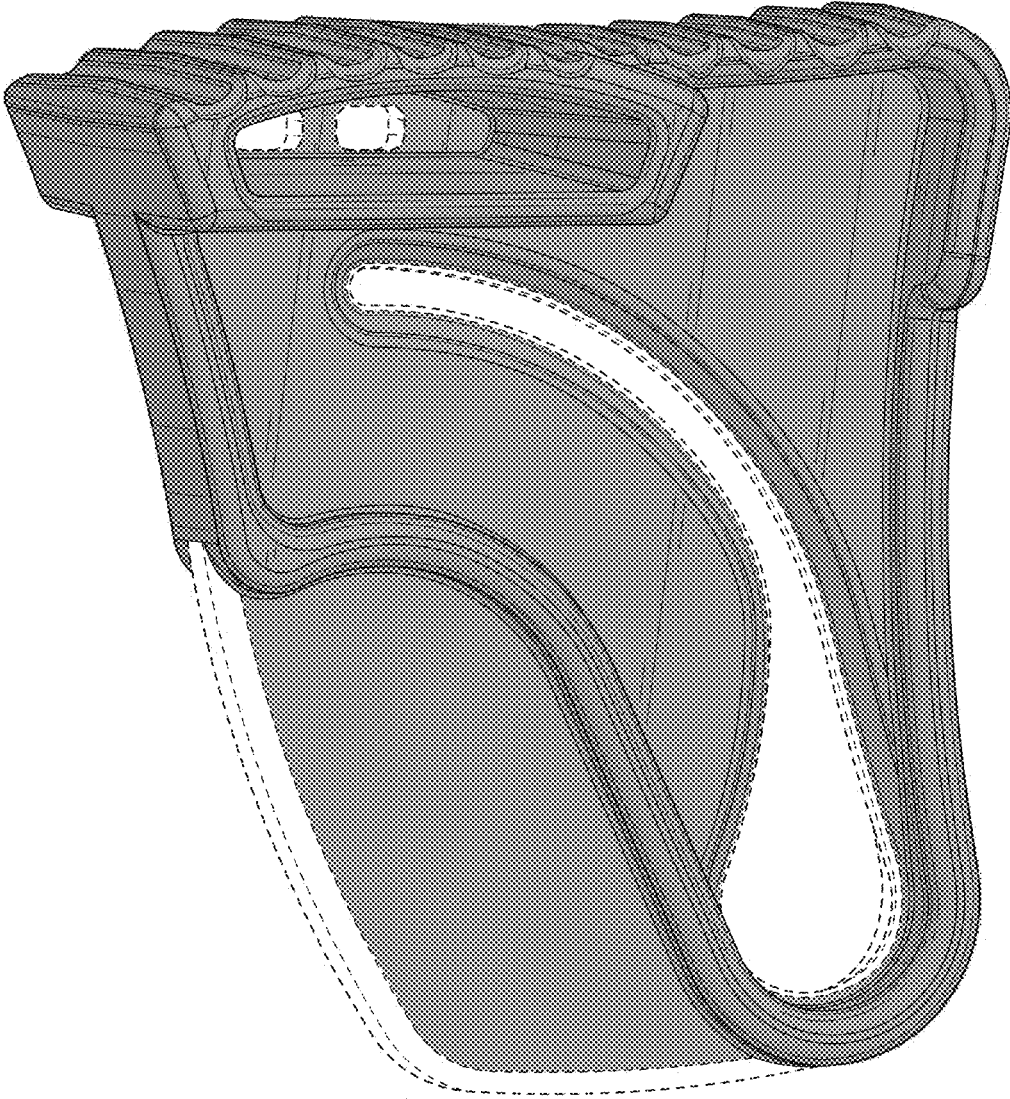

FIG. 8

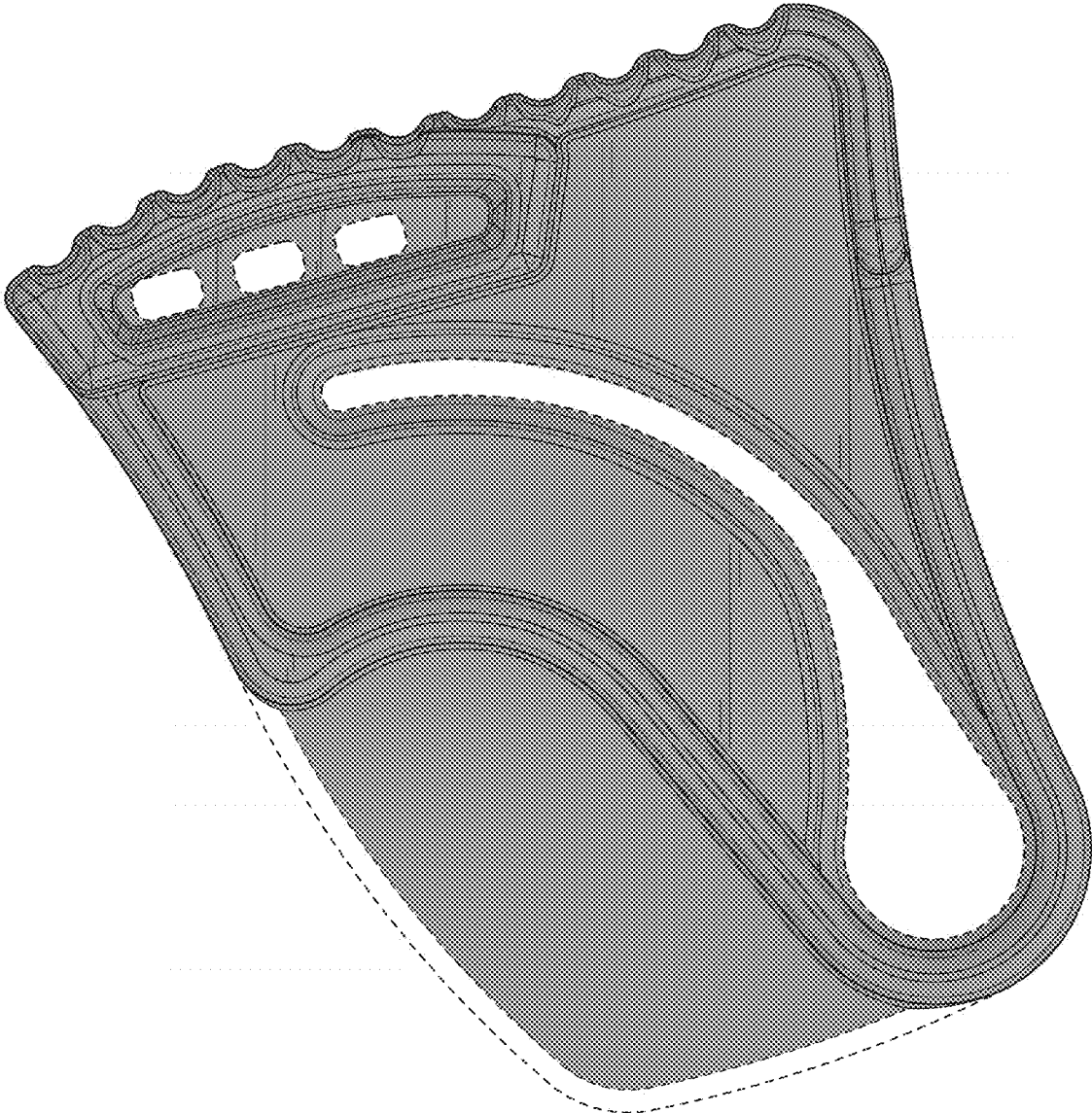

FIG. 9

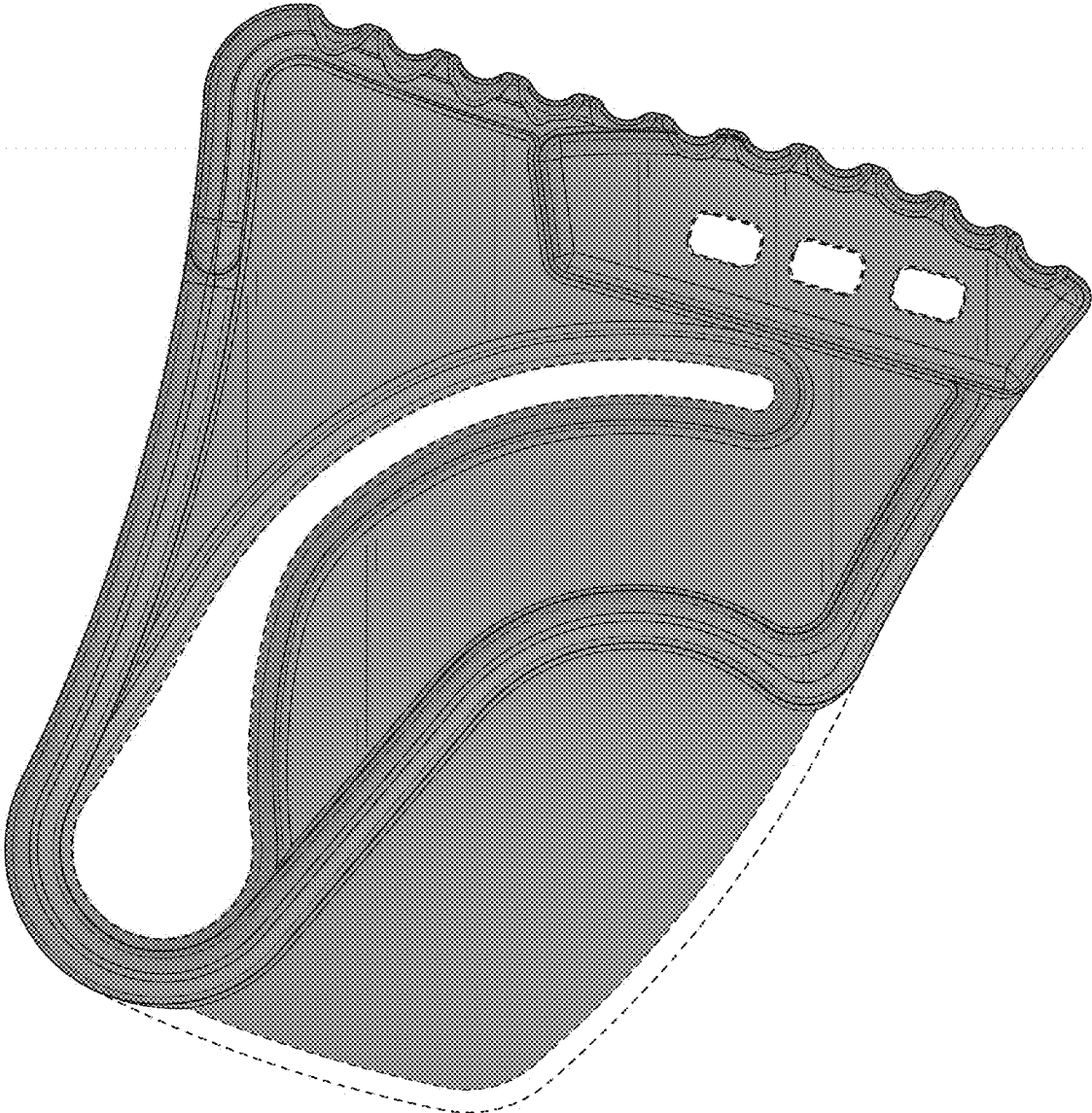

FIG. 10

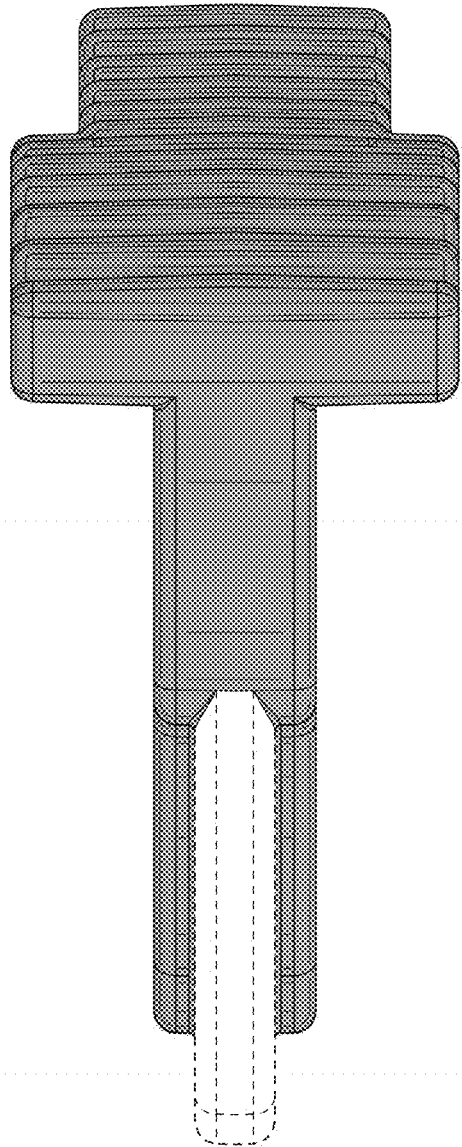

FIG. 11

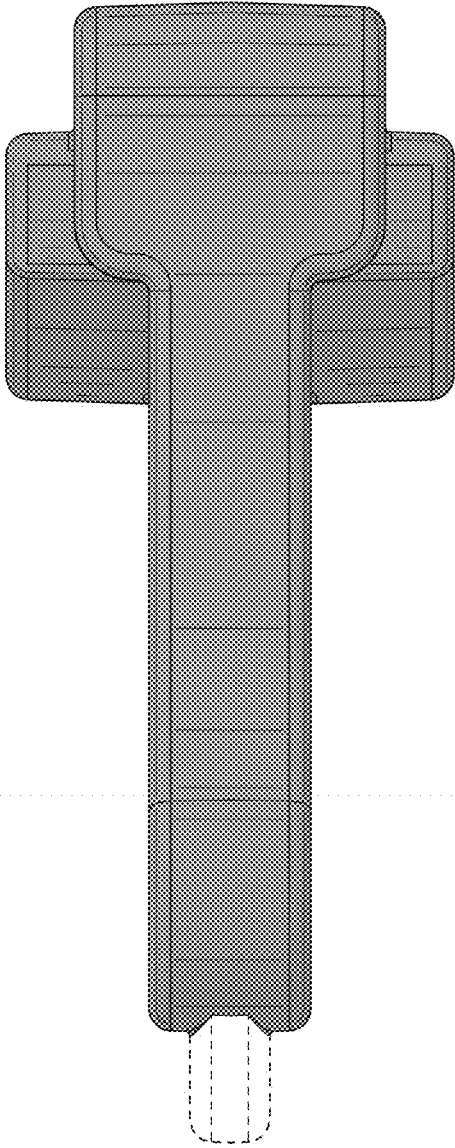

FIG. 12

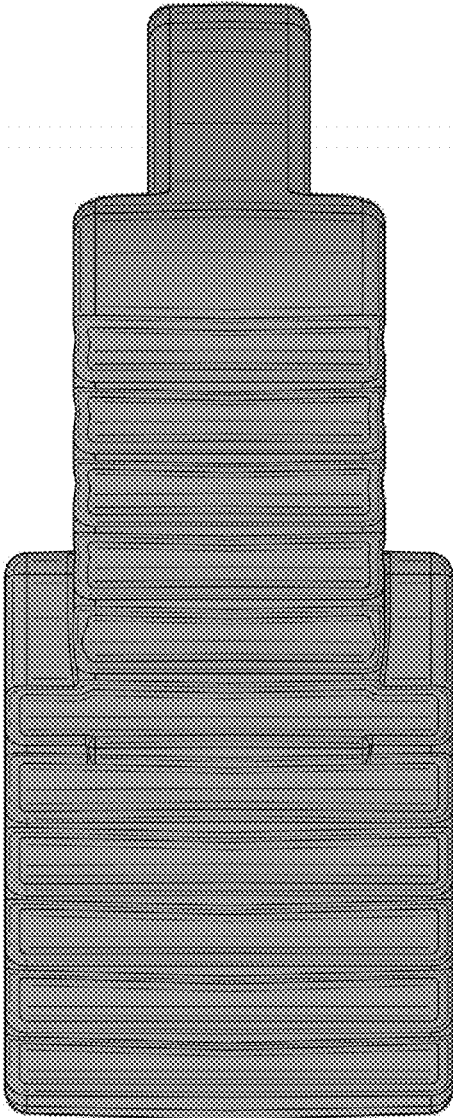

FIG. 13

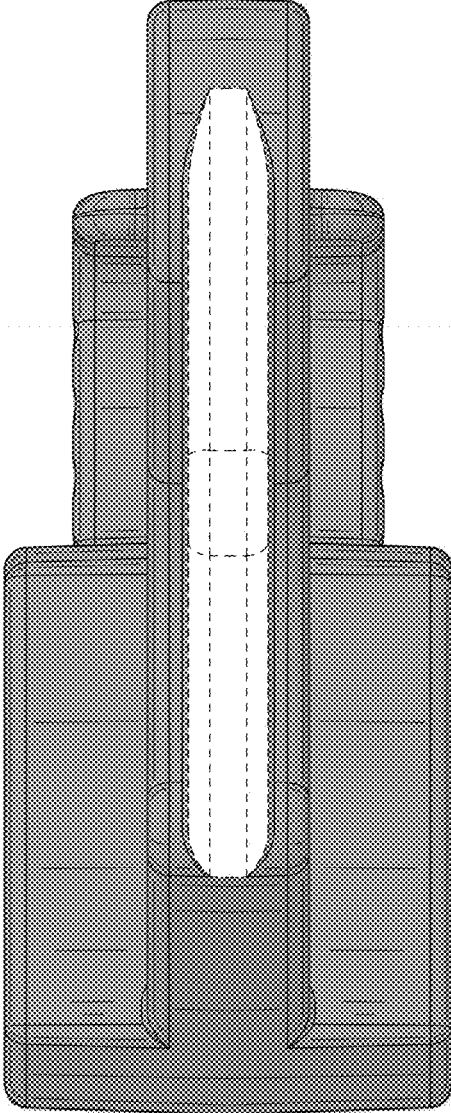

FIG. 14