

(19) World Intellectual Property Organization  
International Bureau



(43) International Publication Date  
26 April 2007 (26.04.2007)

PCT

(10) International Publication Number  
**WO 2007/046565 A1**

(51) International Patent Classification:  
*F01P 5/10* (2006.01)

(21) International Application Number:  
PCT/KR2005/003507

(22) International Filing Date: 21 October 2005 (21.10.2005)

(25) Filing Language: English

(26) Publication Language: English

(71) Applicant (for all designated States except US): **MYUNG HWA IND. CO., LTD.** [KR/KR]; Technical Research Institute, 273, Bugok-dong, Nam-gu, Ulsan 680-110 (KR).

(72) Inventor; and

(75) Inventor/Applicant (for US only): **OH, Tae Sung** [KR/KR]; 706-808, Jugong Apt., Gojan 2-dong, Danwon-gu, Ansan-si, Gyeonggi-do 425-724 (KR).

(74) Agent: **CHANG & HAN PATENT & LAW FIRM**; 1007, 10Fl. Woolim e-Biz Center 2, 184-1, Guro-dong, Guro-gu, Seoul 152-848 (KR).

(81) Designated States (unless otherwise indicated, for every kind of national protection available): AE, AG, AL, AM, AT, AU, AZ, BA, BB, BG, BR, BW, BY, BZ, CA, CH, CN, CO, CR, CU, CZ, DE, DK, DM, DZ, EC, EE, EG, ES, FI, GB, GD, GE, GH, GM, HR, HU, ID, IL, IN, IS, JP, KE, KG, KM, KP, KZ, LC, LK, LR, LS, LT, LU, LV, LY, MA, MD, MG, MK, MN, MW, MX, MZ, NA, NG, NI, NO, NZ, OM, PG, PH, PL, PT, RO, RU, SC, SD, SE, SG, SK, SL, SM, SY, TJ, TM, TN, TR, TT, TZ, UA, UG, US, UZ, VC, VN, YU, ZA, ZM, ZW.

(84) Designated States (unless otherwise indicated, for every kind of regional protection available): ARIPO (BW, GH, GM, KE, LS, MW, MZ, NA, SD, SL, SZ, TZ, UG, ZM, ZW), Eurasian (AM, AZ, BY, KG, KZ, MD, RU, TJ, TM), European (AT, BE, BG, CH, CY, CZ, DE, DK, EE, ES, FI, FR, GB, GR, HU, IE, IS, IT, LT, LU, LV, MC, NL, PL, PT, RO, SE, SI, SK, TR), OAPI (BF, BJ, CF, CG, CI, CM, GA, GN, GQ, GW, ML, MR, NE, SN, TD, TG).

Published:

— with international search report

For two-letter codes and other abbreviations, refer to the "Guidance Notes on Codes and Abbreviations" appearing at the beginning of each regular issue of the PCT Gazette.

(54) Title: METHOD OF MANUFACTURING WATER PUMP IMPELLER ASSEMBLY USING INJECTION MOLD

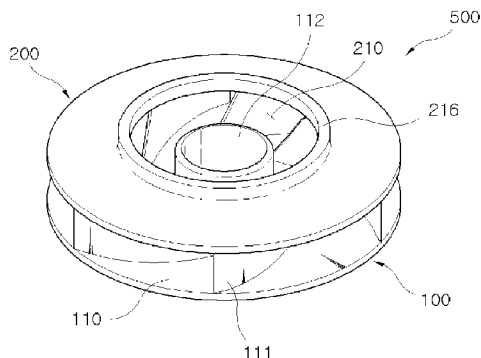

(57) Abstract: The present invention relates to a method of manufacturing an impeller assembly using an injection mold. The method includes: arranging a bottom mold plate, a first slide core, a second slide core, and a top mold plate in the injection mold for injection-molding the impeller assembly; separating the top mold plate from the impeller assembly; moving the first slide core in an outward direction by the core inclined pin connected to the top mold plate while the top mold plate is separated; pushing the impeller assembly by the bottom pin of the bottom mold plate and separating the impeller assembly from the bottom mold plate thereby; and moving the second slide core in an outward direction through the pulling pin which is moved together with the slide core driving plate in an outward direction.

WO 2007/046565 A1

## Description

# METHOD OF MANUFACTURING WATER PUMP IMPELLER ASSEMBLY USING INJECTION MOLD

### Technical Field

- [1] The present invention relates to a water pump for vehicle; and, more particularly, to a method of manufacturing an impeller assembly forcedly circulating coolant.

### Background Art

- [2] A water pump for vehicle's engine is a device that forcedly circulates coolant inside the engine. Such a water pump includes an impeller, a mechanical seal, a driving bearing and a body. The water pump for the engine receives rotational energy from an engine crankshaft or an electric motor and transforms the rotational energy to kinetic energy of coolant through vanes of the impeller to forcedly circulating the coolant.
- [3] FIG. 1 shows a water pump impeller used to forcedly circulate coolant according to the related art.
- [4] Referring to FIG. 1, the water pump impeller 50 according to the related art includes: a top impeller member 20 having a boss 12 and a plurality of vanes; and a bottom impeller member 30 having a circular hole at a center. At the center of the boss 12, a through hole is formed and the plurality of vanes is radially formed from the boss 12.
- [5] Theses top and bottom impeller members 20 and 30 are separately manufactured pressing cold rolling steel plates and then the top impeller member 20 and the bottom impeller member 30 are integrally assembled. In order to assemble the top and bottom impeller members 20 and 30, the center of the boss 12 in the top impeller member 20 and the center of the circular hole 13 in the bottom impeller member 30 are matched, and the top impeller member 20 and the bottom impeller member 30 are welded together.
- [6] A flow of coolant inside an impeller when the water pump impeller is manufactured pressing the cold rolling steel plate is not shown in drawings.
- [7] But, as a result of experiment, we understand that the inflow coolant runs against the vanes at a coolant inflow region. Furthermore, a whirlpool arises at a side of the vane in a coolant outflow region. And the whirlpool also arises at a coolant inflow region.
- [8] Water pump impellers currently used in vehicles are generally manufactured by welding cold rolling steel plates. Because of the structural limitations of pressing the cold rolling steel plate, a design of a vane also has limited conditions. Therefore, the conventional water pump impeller has hydraulic losses caused by leakage between the

vanes, collision of the vanes and the inflow coolant, and the whirlpool because of the limited design conditions of the vane. Accordingly, the efficiency of the conventional water pump is degraded.

## **Disclosure of Invention**

### **Technical Problem**

- [9] It is, therefore, an object of the present invention to provide a method of manufacturing an impeller assembly to reduce hydraulic losses caused by collision between vanes and inflow coolant and a whirlpool and to prevent leakages between vanes by forming vanes of the impeller assembly to having an optimized shape.

### **Technical Solution**

- [10] In accordance with an aspect of the present invention, there is provided a method of manufacturing an impeller assembly for a water pump impeller of a vehicle using an injection mold, the method including: arranging a bottom mold plate having a bottom pin for pushing the impeller assembly, a first slide core having a slide core driving plate at one side, a second slide core having multiple surfaces slidably and horizontally coupled to the first slide core, and a top mold plate having a core inclined pin for moving the first slide core in an outward direction from the impeller assembly in the injection mold for injection-molding the impeller assembly, wherein the second slide core has a pulling pin connected to the first slide core that is moved with the first slide core and a guide hole for receiving the pulling pin; injecting an injection material into the injection mold and solidifying the injection material; separating the top mold plate from the impeller assembly; moving the first slide core in an outward direction by the core inclined pin connected to the top mold plate while the top mold plate is separated; pushing the impeller assembly by the bottom pin of the bottom mold plate and separating the impeller assembly from the bottom mold plate thereby; and moving the second slide core in an outward direction through the pulling pin which is moved together with the slide core driving plate in an outward direction.

- [11] The impeller assembly may include an impeller having a circular plate and a shroud, where a boss having a through hole is formed at a center of the circular plate, and a plurality of vanes is radially disposed from the boss at one side of the circular plate with an inclination of 20° to 30°, and the shroud is disposed over the vanes to face the circular plate.

- [12] The impeller assembly may be made of an engineering plastic material.

- [13] A thickness of the vane may be gradually thinner toward to an outer edge.

### **Advantageous Effects**

- [14] A method of manufacturing a water pump impeller using an injection mold according to the present invention provides following advantageous effects.

[15] At first, hydraulic loss of coolant in the impeller assembly is reduced, and power loss of the water pump for vehicle's engine is reduced by forming vanes having an optimized shape. Therefore, the efficiency of the water pump is improved, and the vehicle's output is also improved.

[16] Secondly, the reliability of impeller is improved by integrally manufacturing the impeller assembly using the injection mold. Therefore, quality of product is improved.

### **Brief Description of the Drawings**

[17] The above and other features and advantages of the present invention will become more apparent by describing in detail exemplary embodiments thereof with reference to the attached drawings in which:

[18] FIG. 1 is an exploded perspective view of a water pump impeller according to the related art;

[19] FIGS. 2 and 3 are a perspective view and a plan view of a water pump impeller according to a preferred embodiment of the present invention;

[20] FIG. 4 is a cross-sectional view of an injection mold used to a method of manufacturing the water pump impeller shown in FIG. 2;

[21] FIGS. 5 through 7 cross-sectional views for describing extracting of the water pump impeller from the injection mold shown in FIG. 4;

### **Best Mode for Carrying Out the Invention**

[22] Hereinafter, a method of manufacturing a water pump impeller assembly for a vehicle using an injection mold will be described in more detail with reference to the accompanying drawings.

[23] FIG. 2 is a perspective view of a water pump impeller according to an embodiment of the present invention, and FIG. 3 is a plan view of the water pump impeller shown in FIG. 2.

[24] Referring to FIG. 2, the impeller assembly 500 includes an impeller 100 and a shroud 200 made of engineering plastic material.

[25] The impeller 100 includes: a circular plate 110 having a boss 112 formed on a center; and a plurality of vanes 111 formed at one side of the circular plate 110. The plurality of vanes 111 is radially formed from the boss 112 with a predetermined angle bended in a direction of the boss 12.

[26] The shroud 200 includes a circular hole 210 and a circular pipe member 216. The circular hole 210 is formed at the center of the shroud 200, and the circular pipe member 216 is projected from the circular hole 210 in a one side direction as long as a predetermined length.

[27] Referring to FIG. 3, the vanes are formed with a vane inflow angle 230 of 23° at a region where a coolant inflow region 210 meets the vane 11, wherein the vane inflow

angle 230 is formed of the vane 111 and the tangential line thereof. The vane is also formed with a vane outflow angle 240 of 25° at a region where a circumference surface of the circular plate 110 meets the vane 111, wherein the vane outflow angle 240 is formed of the vane and the tangential line of the circular plate 110.

[28] The thickness of the vane 111 becomes gradually thinner as closing to the circumference of the circular plate 110. That is, the vane 111 is formed to have a thinner thickness at the circumference of the circular plate 110 than the thickness at the boss 112.

[29] In the present embodiment, the vane inflow angle 230 and the vane outflow angle 240 are 23° and 25°, respectively. However, the vane inflow angle and the vane outflow angle in a range of 20° to 30° may give same results according to simulations.

[30] FIG. 4 is a cross-sectional view of an inject mold used to a method of manufacturing the impeller assembly shown in FIG. 2 according to an embodiment of the present invention.

[31] Referring to FIG. 4, the inject mold 600 includes a top mold plate 310, a slide core driving plate 300 and a bottom mold plate 320.

[32] The top mold plate 310 includes an injection hole 370 to receive injecting material to form the impeller assembly 500. The injecting material injected through the injection hole 370 flows into an inside of the injection mold 600 through a gate 380.

[33] The slide core driving plate 300 is jointed to a first slide core 330, and the first slide core 300 and a second slide core 340 are slidably and horizontally coupled each other.

[34] A pulling pin 350 is formed in the first slide core 330 and a guide hole 351 is formed in the second slide core 340. The pulling pin 350 is inserted into the guide hole 351.

[35] The bottom mold plate 320 includes a core inclined hole 391 to guide a core inclined pin 390 coupled to the top mold plate 310. A bottom pin 360 is mounted at a bottom of the impeller assembly 500.

[36] FIGS 5 through 7 are cross-sectional views of an injection mold for describing extracting the impeller assembly having a under cut from the injection mold.

[37] Referring to FIG. 4, an injecting material is injected into the injection mold 600 through the injection hole 370, and the injected material is solidified to form the impeller assembly 500. If the top mold plate 310 is moved to be separated from the formed impeller assembly 500 as shown in FIG. 5, the core inclined pin 390 connected to the top mold plate 310 is shifted in a same direction of the top mold plate 310 and the first slide code 330 connected to the core inclined pin 390 is moved to the outward direction of the impeller assembly 500 by the inclined surface of the core inclined pin 390.

[38] After then, the bottom bin 360 formed on the bottom mold plate 320 pushes the

impeller assembly 500 to separate the impeller assembly 500 from the bottom mold plate 320. That is, the first slide core 330 is shifted in the outward direction from the impeller assembly 500 by the inclined surface of the core incline pin 390 while the core incline pin 390 of the top mold plate 310 is moved. When the first slide core 330 is shifted, an empty space is formed in the impeller assembly 500 by the shifted first slide core 330. Accordingly, the impeller assembly 500 is pushed by the bottom pin 360 as much as the formed empty space, and the impeller assembly 500 is separated from the bottom mold plate 320 thereby.

- [39] That is, when the slide core driving plate 300 is moved, the first slide core 330 connected to the slide core driving plate 300 is also moved in the same direction of the moved slide core driving plate 300. Herein, the pulling pin 350 is moved along the guide hole 351 formed in the second slide core 340. The second slide core 340 is pulled by the pulling pin 350 in order to move in an outward direction from the impeller assembly 500.
- [40] A flow of coolant in the impeller assembly according to the present invention is now shown, but we understand, as a experiment result, that the collusion between the vanes and the flow of coolant around the coolant inflow region are reduced, the whirlpool is not occurred around the coolant outflow region. And the hydraulic loss is minimized by the impeller assembly according to the present invention, which includes vanes having the optimized shape and angles. That is, the efficiency of the water pump is maximally optimized.
- [41] Since the shroud is disposed to cover entire surface of the impeller, the leakage between the vanes 111 is reduced.
- [42] As described above, the impeller assembly manufactured using the injection mold according to the present invention includes the vanes having the optimized shape and angle. Accordingly, the hydraulic loss caused by the collusion between the vanes and the flow of coolant and the whirlpools is reduced. Furthermore, the reliability of the impeller assembly is improved since the impeller assembly is manufactured by integrally forming the impeller and the shroud without welding the shroud and the impeller.
- [43] While the present invention has been particularly shown and described with reference to exemplary embodiments thereof, it will be understood by those of ordinary skill in the art that various changes in form and details may be made therein without departing from the spirit and scope of the present invention as defined by the following claims.
- [44]

## Claims

- [1] A method of manufacturing an impeller assembly for a water pump impeller of a vehicle using an injection mold, the method comprising:  
arranging a bottom mold plate having a bottom pin for pushing the impeller assembly, a first slide core having a slide core driving plate at one side, a second slide core having multiple surfaces slidably and horizontally coupled to the first slide core, and a top mold plate having a core inclined pin for moving the first slide core in an outward direction from the impeller assembly in the injection mold for injection-molding the impeller assembly, wherein the second slide core has a pulling pin connected to the first slide core that is moved with the first slide core and a guide hole for receiving the pulling pin;  
injecting an injection material into the injection mold and solidifying the injection material;  
separating the top mold plate from the impeller assembly;  
moving the first slide core in an outward direction by the core inclined pin connected to the top mold plate while the top mold plate is separated;  
pushing the impeller assembly by the bottom pin of the bottom mold plate and separating the impeller assembly from the bottom mold plate thereby; and  
moving the second slide core in an outward direction through the pulling pin which is moved together with the slide core driving plate in an outward direction.
- [2] The method of claim 1, wherein the impeller assembly includes an impeller having a circular plate and a shroud, where a boss having a through hole is formed at a center of the circular plate, and a plurality of vanes is radially disposed from the boss at one side of the circular plate with an inclination of 20° to 30°, and the shroud is disposed over the vanes to face the circular plate.
- [3] The method of claim 1, wherein the impeller assembly is made of an engineering plastic material.
- [4] The method of any one of claims 2 and 3, wherein a thickness of the vane is gradually thinner toward to an outer edge.

[Fig. 1]

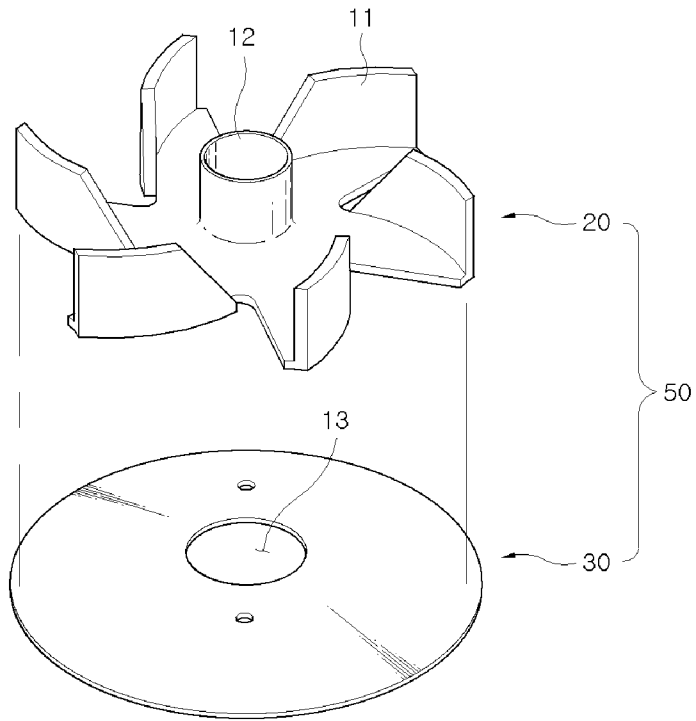

[Fig. 2]

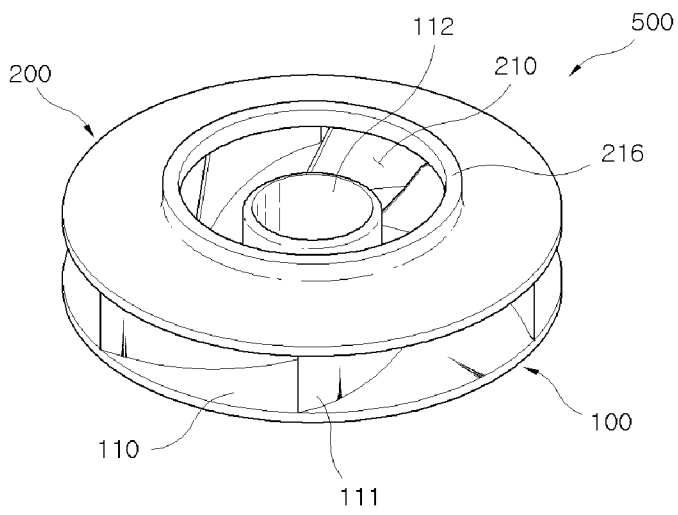

[Fig. 3]

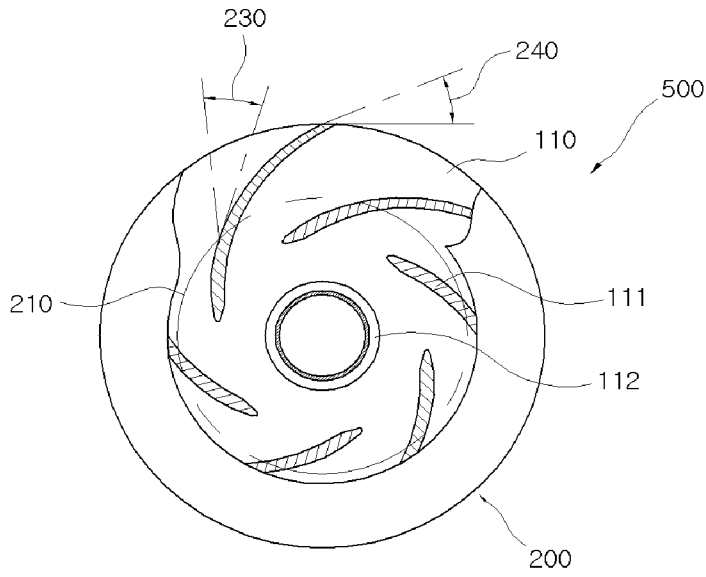

[Fig. 4]

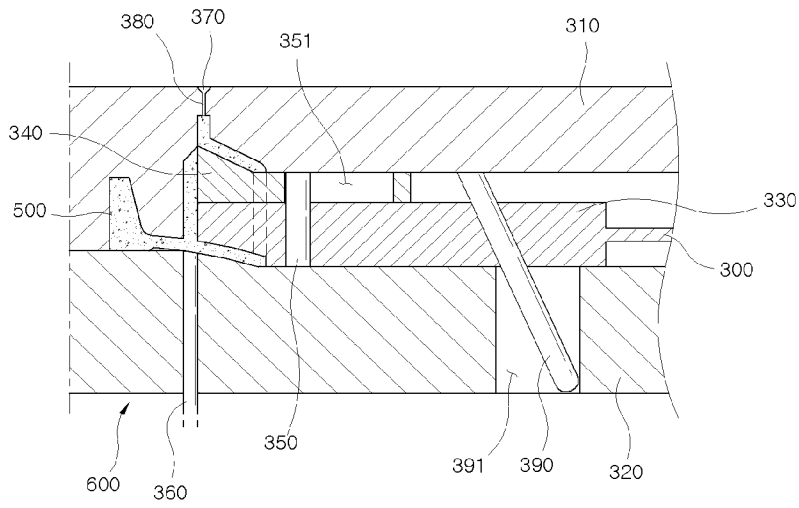

[Fig. 5]

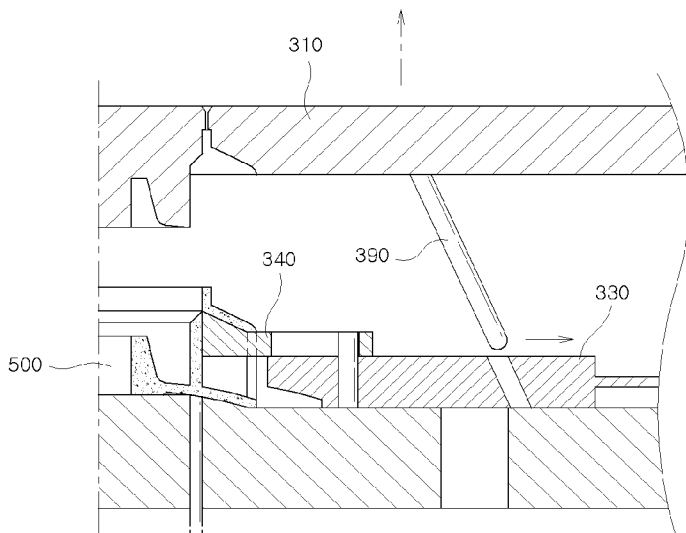

[Fig. 6]

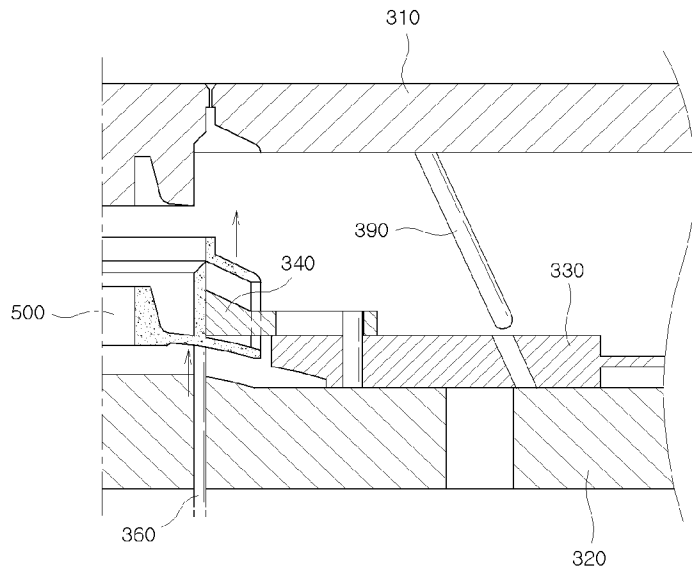

[Fig. 7]

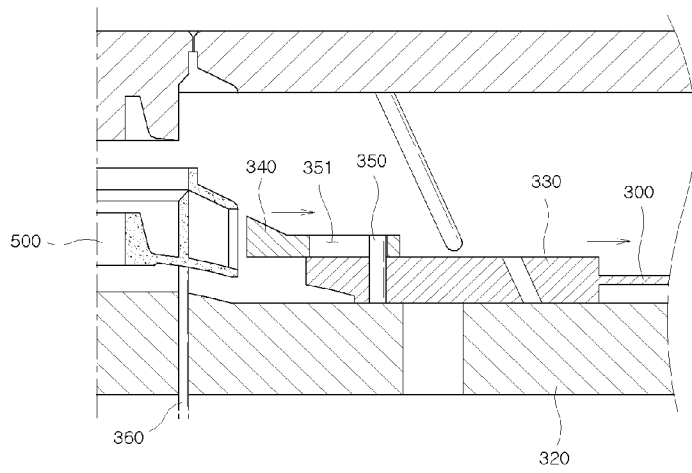

# INTERNATIONAL SEARCH REPORT

International application No.  
PCT/KR2005/003507

<b>A. CLASSIFICATION OF SUBJECT MATTER</b>				
<i>F01P 5/10(2006.01)i</i>				
According to International Patent Classification (IPC) or to both national classification and IPC				
<b>B. FIELDS SEARCHED</b>				
Minimum documentation searched (classification system followed by classification symbols) IPC 8: B21C, B21D, B22D, B29C, F04D				
Documentation searched other than minimum documentation to the extent that such documents are included in the fields searched  KR, JP IPC as above				
Electronic data base consulted during the international search (name of data base and, where practicable, search terms used)  eKIPASS(KIPO internal)				
<b>C. DOCUMENTS CONSIDERED TO BE RELEVANT</b>				
Category*	Citation of document, with indication, where appropriate, of the relevant passages	Relevant to claim No.		
X	KR 10-0508683 B1 (Myong Hwa Ind. Co., Ltd.) 17 August 2005 See claim 1-4	1-4		
A	JP 2003-35296 A (Daikin Ind. Ltd.) 7 February 2003 See the Abstract and Fig.2	1		
A	JP 2003-39498 A (Japan Crown Cork Co.Ltd.) 13 February 2003 See page 3 and Fig. 1	1		
<input type="checkbox"/> Further documents are listed in the continuation of Box C. <span style="margin-left: 100px;"><input checked="" type="checkbox"/> See patent family annex.</span>				
<table style="width: 100%; border: none;"> <tr> <td style="width: 50%; border: none; vertical-align: top;">                     * Special categories of cited documents:                      "A" document defining the general state of the art which is not considered to be of particular relevance                      "E" earlier application or patent but published on or after the international filing date                      "L" document which may throw doubts on priority claim(s) or which is cited to establish the publication date of citation or other special reason (as specified)                      "O" document referring to an oral disclosure, use, exhibition or other means                      "P" document published prior to the international filing date but later than the priority date claimed                 </td> <td style="width: 50%; border: none; vertical-align: top;">                     "T" later document published after the international filing date or priority date and not in conflict with the application but cited to understand the principle or theory underlying the invention                      "X" document of particular relevance; the claimed invention cannot be considered novel or cannot be considered to involve an inventive step when the document is taken alone                      "Y" document of particular relevance; the claimed invention cannot be considered to involve an inventive step when the document is combined with one or more other such documents, such combination being obvious to a person skilled in the art                      "&amp;" document member of the same patent family                 </td> </tr> </table>			* Special categories of cited documents: "A" document defining the general state of the art which is not considered to be of particular relevance "E" earlier application or patent but published on or after the international filing date "L" document which may throw doubts on priority claim(s) or which is cited to establish the publication date of citation or other special reason (as specified) "O" document referring to an oral disclosure, use, exhibition or other means "P" document published prior to the international filing date but later than the priority date claimed	"T" later document published after the international filing date or priority date and not in conflict with the application but cited to understand the principle or theory underlying the invention "X" document of particular relevance; the claimed invention cannot be considered novel or cannot be considered to involve an inventive step when the document is taken alone "Y" document of particular relevance; the claimed invention cannot be considered to involve an inventive step when the document is combined with one or more other such documents, such combination being obvious to a person skilled in the art "&" document member of the same patent family
* Special categories of cited documents: "A" document defining the general state of the art which is not considered to be of particular relevance "E" earlier application or patent but published on or after the international filing date "L" document which may throw doubts on priority claim(s) or which is cited to establish the publication date of citation or other special reason (as specified) "O" document referring to an oral disclosure, use, exhibition or other means "P" document published prior to the international filing date but later than the priority date claimed	"T" later document published after the international filing date or priority date and not in conflict with the application but cited to understand the principle or theory underlying the invention "X" document of particular relevance; the claimed invention cannot be considered novel or cannot be considered to involve an inventive step when the document is taken alone "Y" document of particular relevance; the claimed invention cannot be considered to involve an inventive step when the document is combined with one or more other such documents, such combination being obvious to a person skilled in the art "&" document member of the same patent family			
Date of the actual completion of the international search  03 JULY 2006 (03.07.2006)		Date of mailing of the international search report  <b>03 JULY 2006 (03.07.2006)</b>		
Name and mailing address of the ISA/KR Korean Intellectual Property Office 920 Dunsan-dong, Seo-gu, Daejeon 302-701, Republic of Korea Facsimile No. 82-42-472-7140		Authorized officer  SONG, Jay Wook  Telephone No. 82-42-481-5487  		

# INTERNATIONAL SEARCH REPORT

Information on patent family members

International application No.

PCT/KR2005/003507

Patent document cited in search report	Publication date	Patent family member(s)	Publication date
KR 10-0508683 B1	17-08-2005	None	
JP 2003-35296 A	07-02-2003	None	
JP 2003-39498 A	13-02-2003	None	