

Nov. 6, 1934.

E. ROOS

1,979,843

COLLAPSIBLE TABLE

Filed Jan. 19, 1933

2 Sheets-Sheet 1

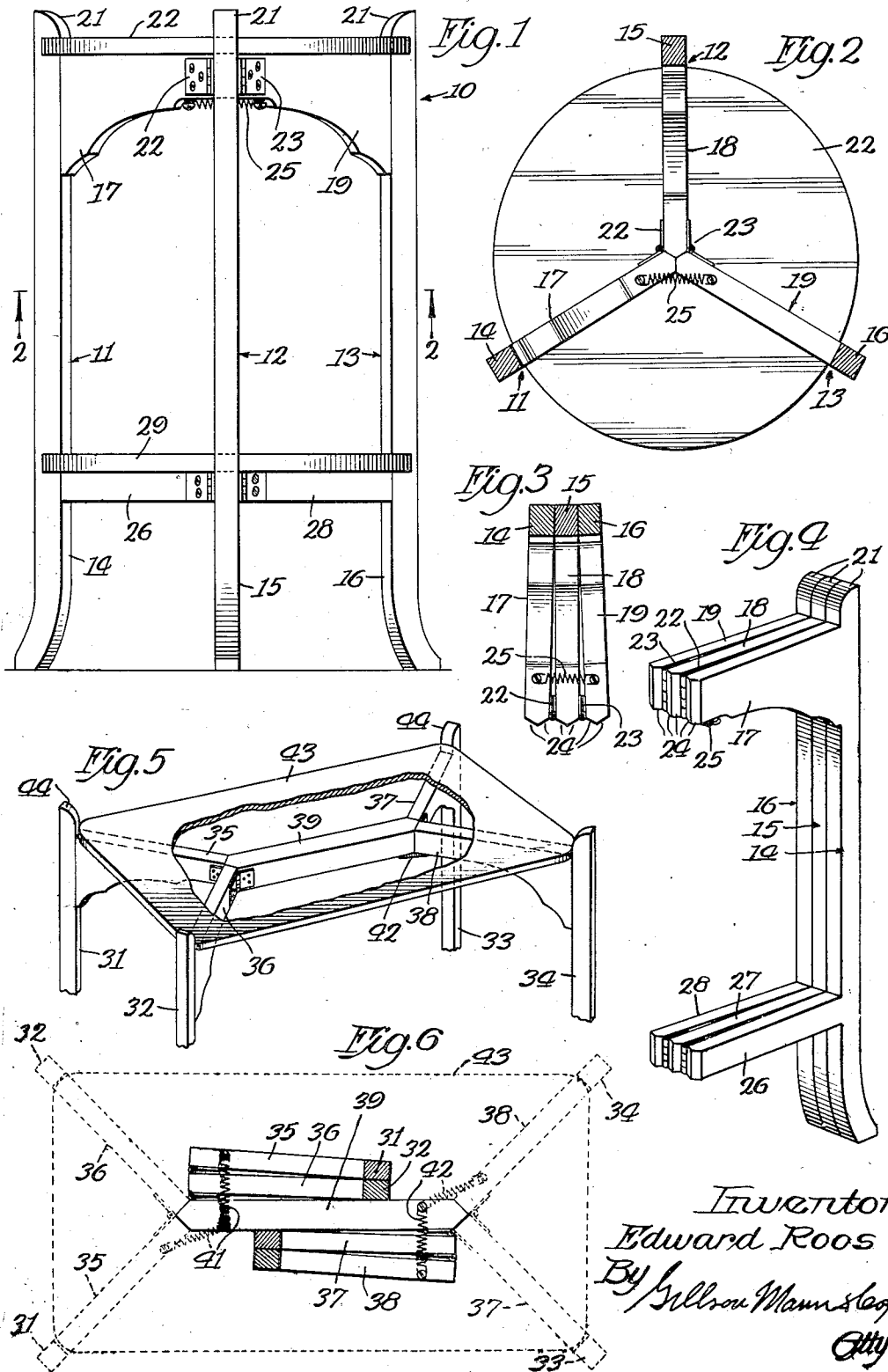

Inventor
Edward Roos
By *William Mann & Co.*
Attys

Nov. 6, 1934.

E. ROOS

1,979,843

COLLAPSIBLE TABLE

Filed Jan. 19, 1933

2 Sheets-Sheet 2

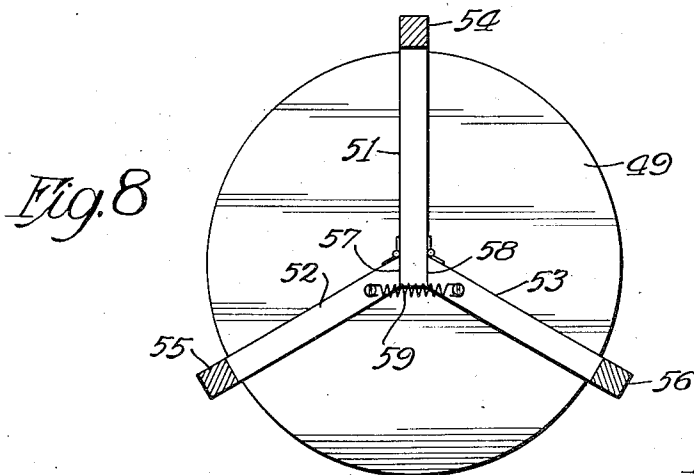
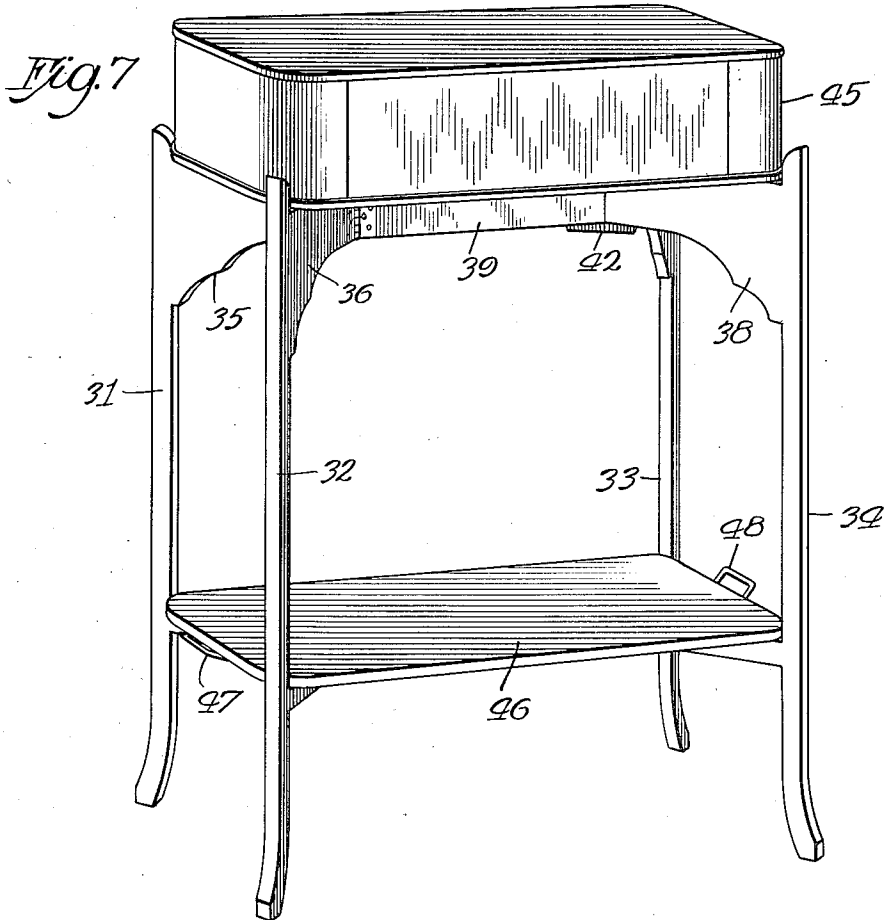

Inventor:
Edward Roos
By Gillson, Mann & Co., Attys.

UNITED STATES PATENT OFFICE

1,979,843

COLLAPSIBLE TABLE

Edward Roos, River Forest, Ill.

Application January 19, 1933, Serial No. 652,495

5 Claims. (Cl. 45—117)

This invention relates to stands or tables and, more particularly, to foldable or collapsible stands, supports or tables for temporary use.

The principal object of the invention is the provision of a collapsible structure that may be readily collapsed to occupy a minimum space and when extended may be employed for numerous uses such as a card table, a book or magazine support, general utility table, and the like.

Another object of the invention is the provision of a new and useful supporting frame structure that may be readily extended or collapsed and which is provided with novel means for resiliently holding the structure in either operative or inoperative position.

A further object of the invention is the provision of a new and improved collapsible support that is provided with a novel arrangement whereby when the parts are moved past a predetermined position in one direction, they will automatically fold and when moved past this position in the opposite direction, they will be automatically moved to operative or supporting position.

A still further object of the invention is the provision of a new and improved collapsible support or stand that is inexpensive to manufacture, easily assembled, ornamental in appearance, easily extended or collapsed, and when in collapsed position occupies a minimum amount of storage space.

Other and further objects and advantages of the invention will appear from the following description, taken in connection with the accompanying drawings, in which

Fig. 1 is a side elevation of one form of the device;

Fig. 2 is a section on the line 2—2 of Fig. 1;

Fig. 3 is a section of the support similar to that shown in Fig. 2, but showing the same in folded position;

Fig. 4 is a perspective view of supports shown in folded position;

Fig. 5 is a perspective view of a modified form of construction with parts broken away;

Fig. 6 is a plan view of a support showing the same in folded position with parts in section and showing the table in extended position in dotted lines.

Fig. 7 is a perspective view of a modified form of construction; and

Fig. 8 is a view similar to Fig. 2, but showing the modified form of construction.

It is often desirable at card parties and other forms of entertainment in clubs, halls, churches,

hotels, private homes and other buildings, that additional tables, stands and the like be provided for the convenience of guests. Inasmuch as these tables or stands are not in continuous use, they must be stored when not required. It is common practice to provide collapsible tables and stands for this purpose but these devices have heretofore either been expensive or they have been flimsy and unstable. The present invention seeks to remedy these deficiencies by the provision of a table or stand which is inexpensive to manufacture, firm, strong and well constructed and which may be collapsed to occupy a minimum of space while in storage.

Referring now to the drawings, the reference character 10 designates generally one form of a table constructed in accordance with the present invention. In this form of construction, the table is circular and comprises a plurality of supports on which the table top is mounted. As shown, three supports 11, 12 and 13 are employed, the same being arranged 120° apart. The supports 11, 12 and 13 comprise standards or legs 14, 15 and 16 having the laterally extending arms or cross members 17, 18 and 19, respectively.

The standards 14, 15 and 16 may each extend above the laterally extending arms or cross members, as shown at 21, for retaining the table top 22 thereon, as will presently appear.

Suitable means are provided whereby the supports may be collapsed or folded upon each other. Any suitable means may be employed for this purpose.

In the form of construction shown, the inner ends of the arms 17, 18 and 19 are hinged together. The arms 14 and 16 are connected to opposite sides to the inner end of the arm 15 by the hinges 22 and 23, respectively. The inner or meeting ends of the arms 14, 15 and 16 are each beveled on both sides, as shown at 24, whereby when the supports are in operative position, the beveled edges will engage each other, the meeting edges being spaced 120° apart.

It is desirable that means be provided for resiliently holding the support in either its extended or collapsed position. In the form of construction shown, which is by way of example only, a coil spring 25 is employed for this purpose. The spring 25 has its ends anchored to the arms 14 and 16, respectively, at such points, and the spring is of such length, that it is under tension when the supports are extended as shown in Fig. 2 and also when they are collapsed, as shown in Fig. 3. In moving the supports from the position shown in Fig. 3 to the extended posi-

tion shown in Fig. 2, as soon as the spring 25 passes dead center it will tend to move the supports to their operative or extended position. After the supports have been extended, the table top 22 can then be placed in position on the arms and the table is ready for use. The top 22 is shown as being circular in Figs. 1 and 2, but it is evident it may be of any suitable or desirable form.

10 In order to strengthen the table, cross members 26, 27 and 28 similar to the arms 17, 18 and 19 may be employed. If desired, a plurality of shelves or trays 29 may be supported beneath the top 22. As shown, the arms 26, 27 and 28 support the additional shelf or tray 29. By multiplying the number of cross members or arms, additional shelves or trays may be supported.

When the device is to be used as a card table or where a table with an angular top is desired, an additional support may be employed as shown in Fig. 5. In this form of construction, the supports 31, 32, 33 and 34 are provided with arms or cross members 35, 36, 37 and 38 which are similar to or identical with the corresponding arms 17, 18 and 19 of the device previously described. A connecting bar 39 is employed for connecting the cross members at one end of the table to those at the other end thereof. As shown, the cross member 35 is hinged to the cross member 36 which in turn is hinged to the one end of the connecting bar 39 and at the other end of said bar the cross member 37 is connected to said bar and the cross member 38 is connected to the cross member 37. A spring 41 is attached to the cross member 35 and the bar 39 and a spring 42 connects the bar 39 to the cross member 38, as in the previous construction. It will be noted that the cross bar 39 corresponds to one of the cross members in Fig. 2.

40 By lengthening or shortening the bar 39, or by lengthening or shortening the cross members 35, 36, 37 and 38 or by varying the angles formed by the cross members, tables of various dimensions may be constructed. The angle of the meeting faces of the bar and cross members may also be varied in order to change the arrangement of the supporting members, if it is desired to do so. By providing additional cross members and connecting bars, additional shelves or plates may be supported beneath the top 43. When it is desired to use the device, the cross members are moved to the dotted line position shown in Fig. 6, the supports are placed on the floor and the top 43 is placed in position on the cross members and connecting bar inwardly of the extensions 44 of the standards or legs 31, 32, 33 and 34.

If desired, the extensions of the table legs may be in the form of dowels or projections for engaging in corresponding recesses formed in the lower surface of the table top. Or, the top may have openings or recesses for receiving the upwardly extending portions of the legs. In either case, the table top could be enlarged.

65 In small apartments, flats, and the like where space is limited, it is desirable that the furniture used shall be convertible whereby a minimum number of pieces may be employed for serving various uses in the home.

70 In Figs. 7 and 8, there is shown a modified form of construction whereby the device may be converted into a vanity stand, or card table and the like.

75 In the form of the construction shown in Fig. 7, the arrangement of the supports is substantial-

ly the same as that disclosed in Figs. 5 and 6, but instead of employing a shelf or top, as shown at 43, in Fig. 5, a removable vanity case, or box, 45, is substituted therefor. A tray 46 is removably supported on the lower arms. When it is desired to use the device as a table, the case 45 and tray 46 are interchanged.

80 Preferably, though not necessarily, the tray 46 is provided with handles 47 and 48 for convenience in moving and carrying the same. When used as a table, the tray 46 is preferably inverted.

85 When not in use, the case 45 and tray 46 are removed and the supports collapsed, as shown in Fig. 6 of the drawings. The parts can then be stored away in any convenient space.

90 In Fig. 8 is shown a construction in which the vanity case or box 49 is circular instead of rectangular as in Fig. 7. In this form of construction, the arms 51, 52 and 53 of the supporting legs 54, 55 and 56, respectively, are hinged together in a slightly different manner from that disclosed in Figs. 2 and 5.

95 In this form of construction, the arms 52 and 53 are hinged to the sides of the arm 51 and the inner ends of said arms 52 and 53 are bevelled, as at 57 and 58, so that when in operative position, the legs 54, 55 and 56 will be at substantially the same angular distance apart.

100 The arms 52 and 53 are connected by a spring 59 in substantially the same manner as that disclosed in Fig. 2, so that the supports will be held in either operative or inoperative position.

105 It is thought from the foregoing taken in connection with the accompanying drawings that the construction and operation of my device will be apparent to those skilled in the art, and that changes in size, shape, proportion and details of construction may be made without departing from the spirit and scope of the appended claims.

I claim as my invention:

115 1. In a collapsible table, a plurality of upright supports, cross bars connected to said supports, hinges for connecting said cross bars together whereby said bars and supports may be folded together and springs with one terminal attached to one cross bar and the other terminal attached to another cross bar for holding the cross bars in either extended or collapsed position.

120 2. In a collapsible table, a table top, a plurality of legs, means for supporting said top from said legs, hinges for connecting said means together and about which said means may be moved, and spring means movable to opposite sides of said hinges for holding said legs in either folded or extended position, said top being removably mounted on said legs.

125 3. In a collapsible table, a plurality of supports, each support comprising a leg and a cross member, a connecting bar, means at each end of said bar for hingedly connecting the same to the adjacent supports and a spring at each end of said bar connected to said bar and to one of said cross members and movable to opposite sides of said means for holding said supports in either operative, distended position or in their collapsed, inoperative position.

130 4. In a device of the class described, a plurality of supporting legs, an arm extending inwardly from the upper portion of each leg below the upper end thereof, a transverse member, means for hinging the arms at each end of said transverse member to said transverse member, and a vanity box supported on said arms inwardly of the upper ends of said legs, a plurality of arms extending inwardly from an intermediate por- 135

tion of said supporting legs, a tray supported by
 said arms at each end of said transverse member,
 one of said springs being connected to said trans-
 verse member and to one of said arms at one side
 5 of said device and the other spring being connect-
 ed to said transverse member and to an arm at
 the other side of said device, said springs mov-
 able to opposite side of the hinging means where-
 10 by said arms are held by said springs in both ex-
 panded and collapsed position and the arms at
 one end of said member will be held in collapsed
 position at one side of said member and the arms
 at the other end of said member will be held in
 collapsed position on the opposite side thereof.

5. In combination, a table top, a plurality of
 supporting elements including hinged members
 for supporting said top, hinges for connecting
 said members together, said supporting members
 engaging said top and a spring secured directly
 to said hinged members and movable to one po-
 sition to one side of said hinges for automatically
 extending said members to top supporting posi-
 tion and movable to the opposite side of said
 hinges for holding said members in collapsed po-
 sition.

EDWARD ROOS.

15	90
20	95
25	100
30	105
35	110
40	115
45	120
50	125
55	130
60	135
65	140
70	145
75	150