



US 20040060265A1

(19) **United States**

(12) **Patent Application Publication**

Boeckle et al.

(10) **Pub. No.: US 2004/0060265 A1**

(43) **Pub. Date: Apr. 1, 2004**

(54) **CONTROLLING THE FLOW OF A POWDER**

Related U.S. Application Data

(75) Inventors: **Andrew J. Boeckle**, Belmont, CA (US); **Dale W. Ploeger**, Menlo Park, CA (US); **Derrick J. Parks**, Belmont, CA (US); **Diane Brannigan**, Belmont, CA (US)

(60) Provisional application No. 60/392,076, filed on Jun. 27, 2002.

Publication Classification

(51) **Int. Cl.⁷ B65B 1/08**
(52) **U.S. Cl. 53/476; 53/473; 141/67; 141/71**

Correspondence Address:
NEKTAR THERAPEUTICS
150 INDUSTRIAL ROAD
SAN CARLOS, CA 94070 (US)

(57) **ABSTRACT**

An apparatus for filling a receptacle with a powder comprises a hopper adapted to contain a powder pharmaceutical formulation, the hopper comprising an outlet. A vibratable member is positioned in, on, or near the hopper so that the vibratable member is spaced from powder in the hopper, and the vibratable member is capable of fluidizing the powder in the hopper. Powder flowing through the outlet under the control of the vibratable member flows into a receptacle or into a transfer chamber for transport to a receptacle.

(73) Assignee: **Nektar Therapeutics**, San Carlos, CA

(21) Appl. No.: **10/609,132**

(22) Filed: **Jun. 26, 2003**

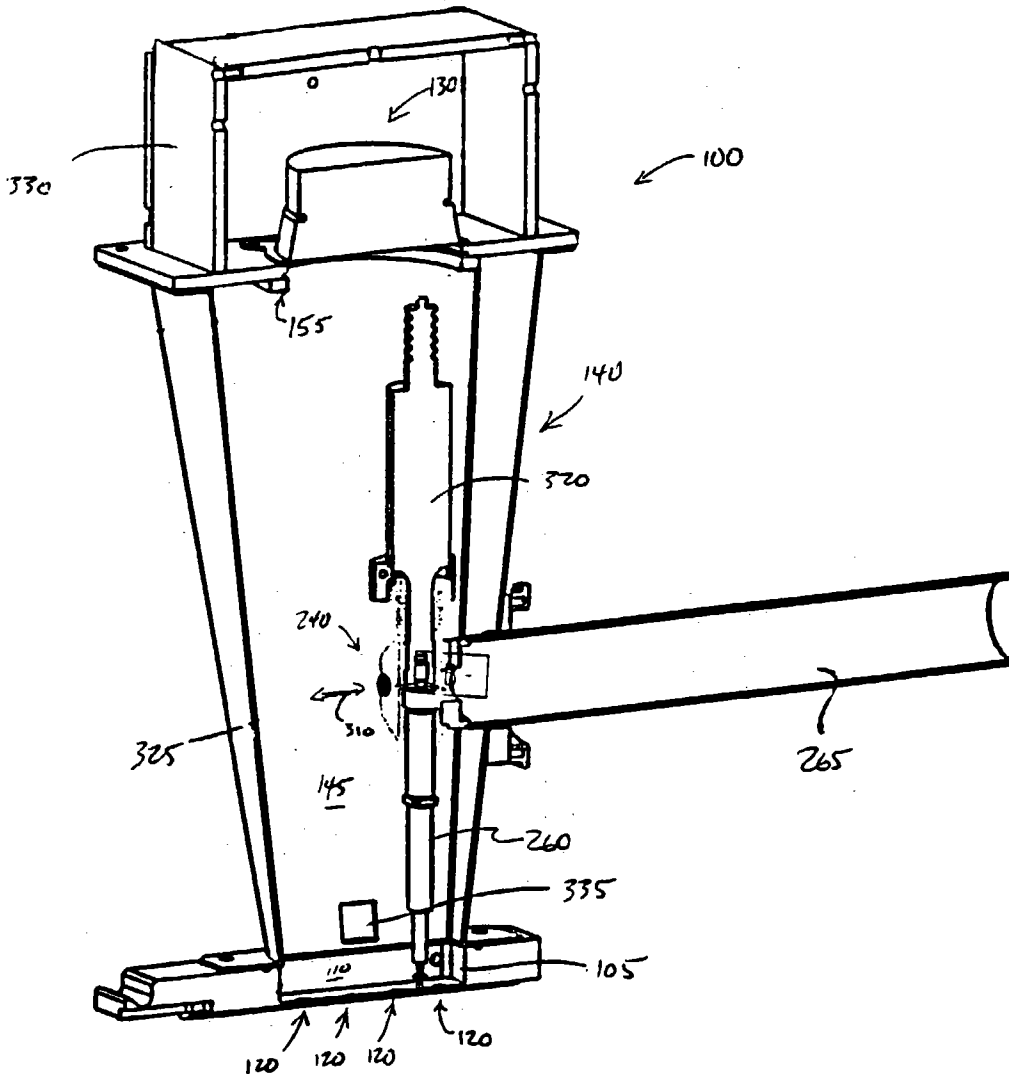

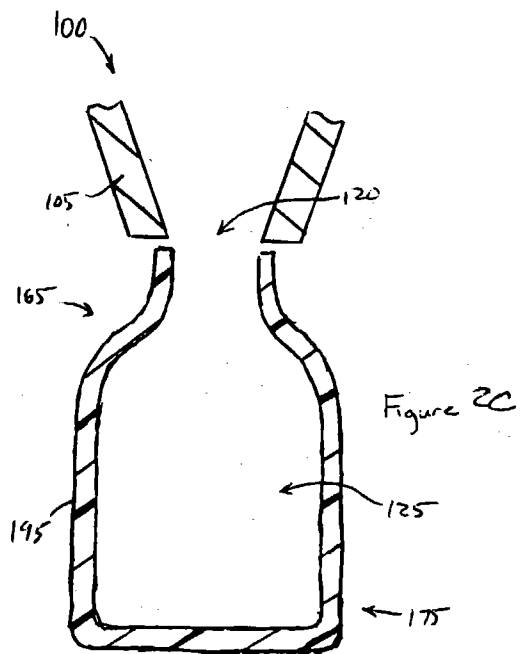
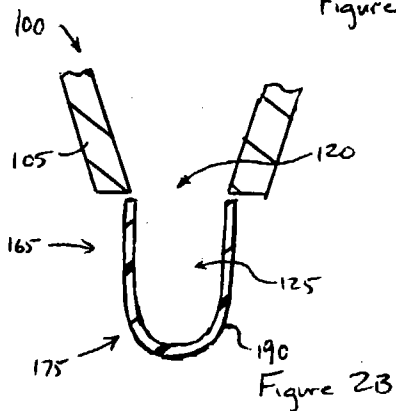
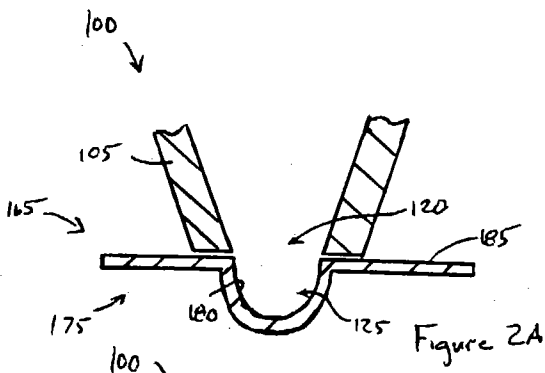
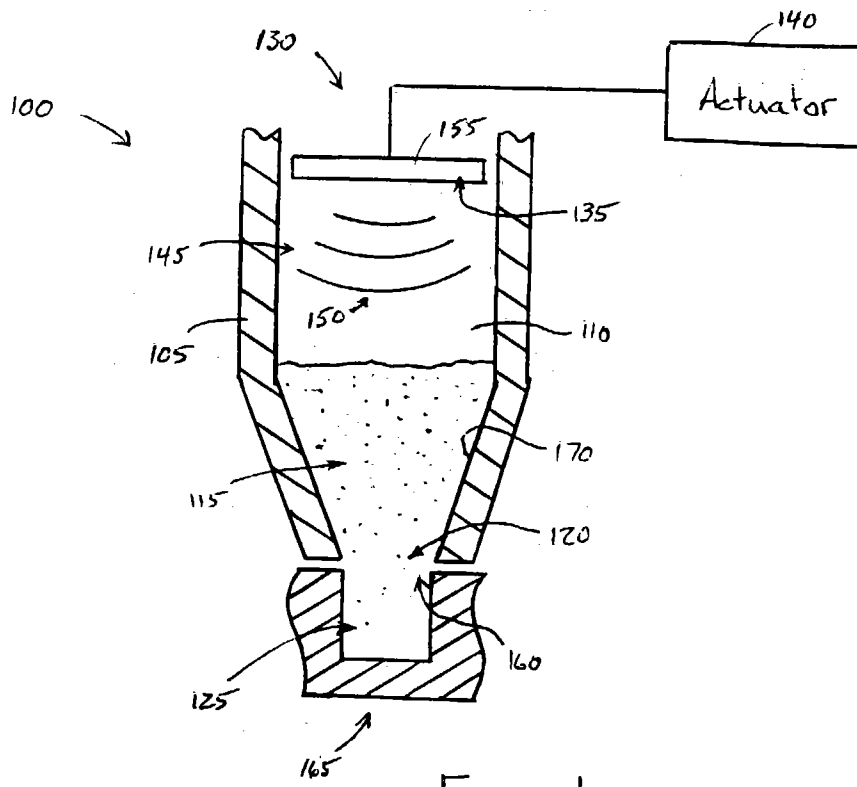

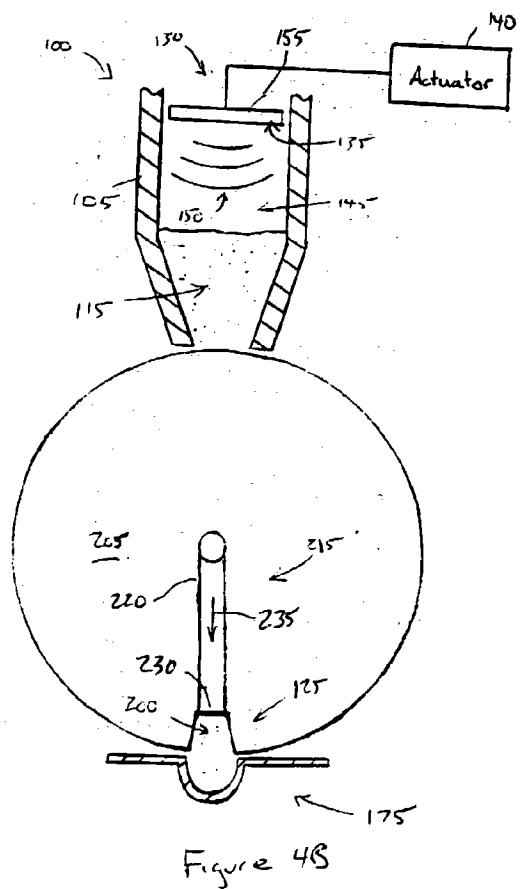
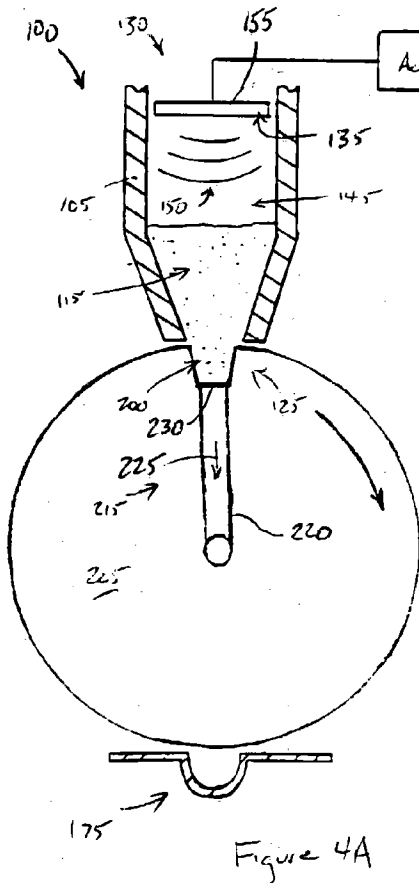
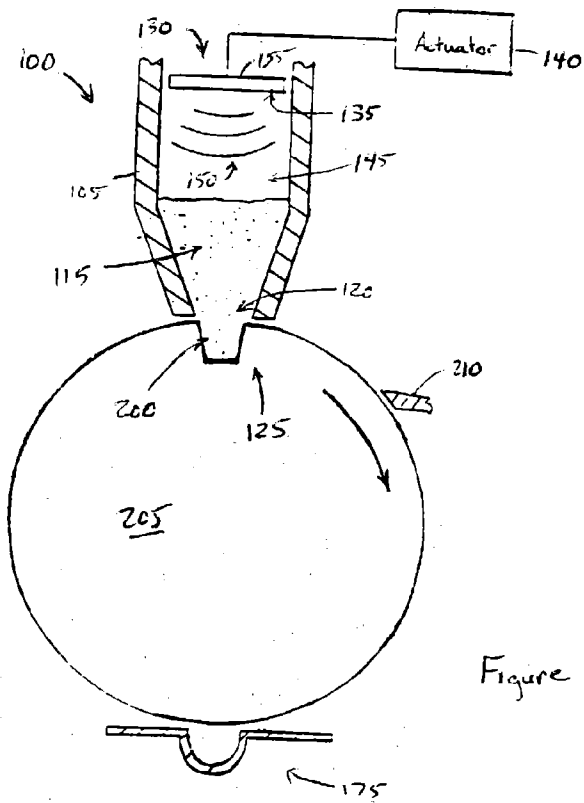

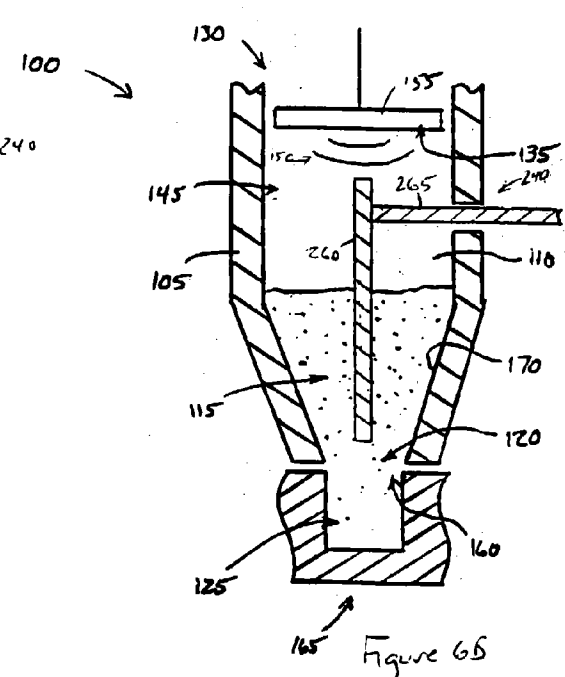
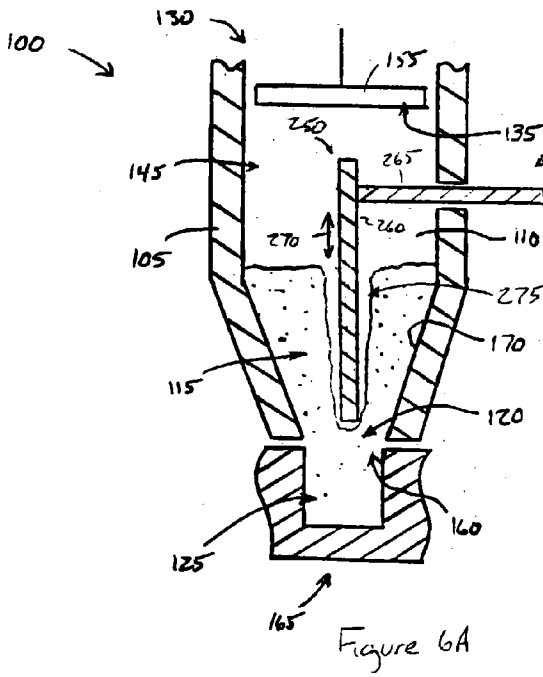
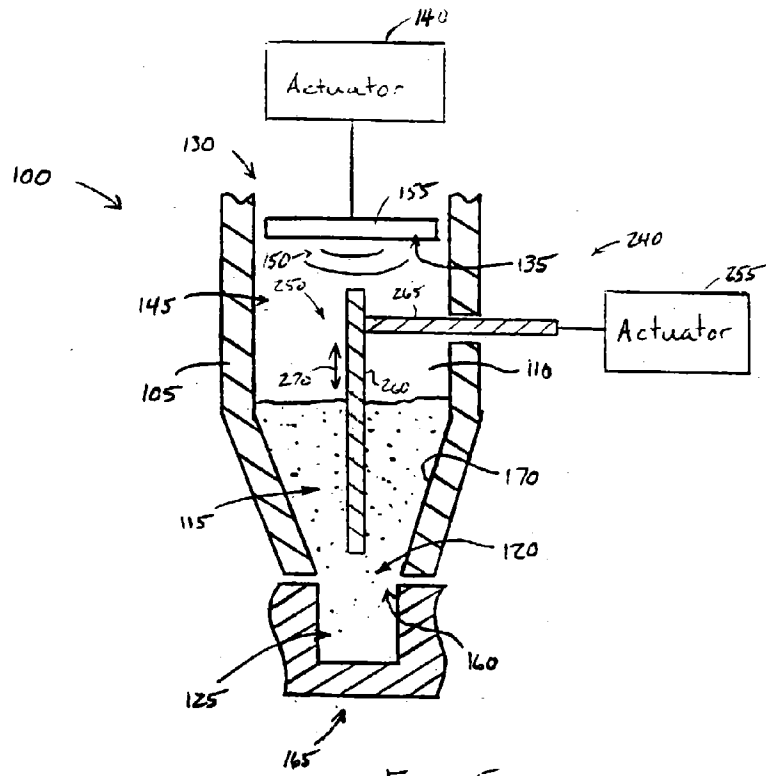

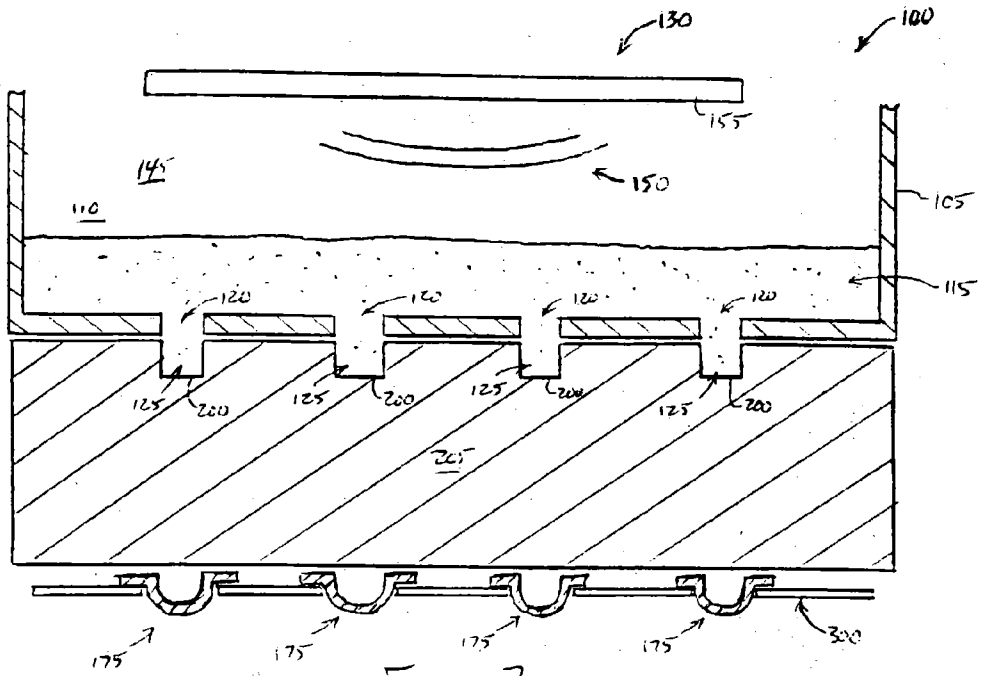

Figure 7

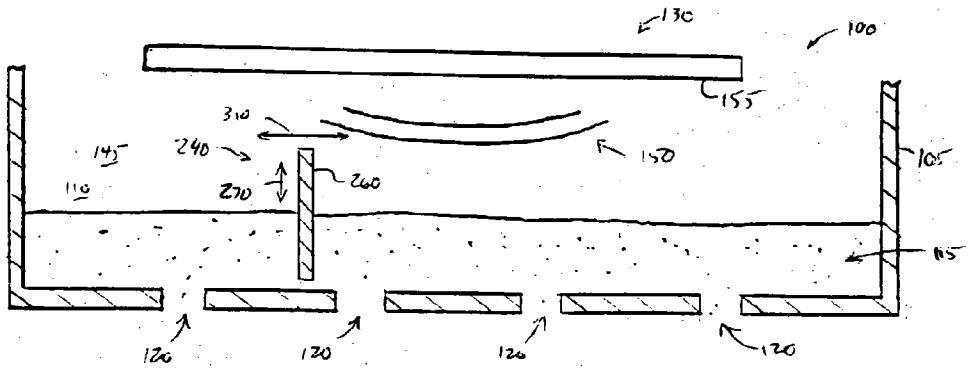

Figure 8A

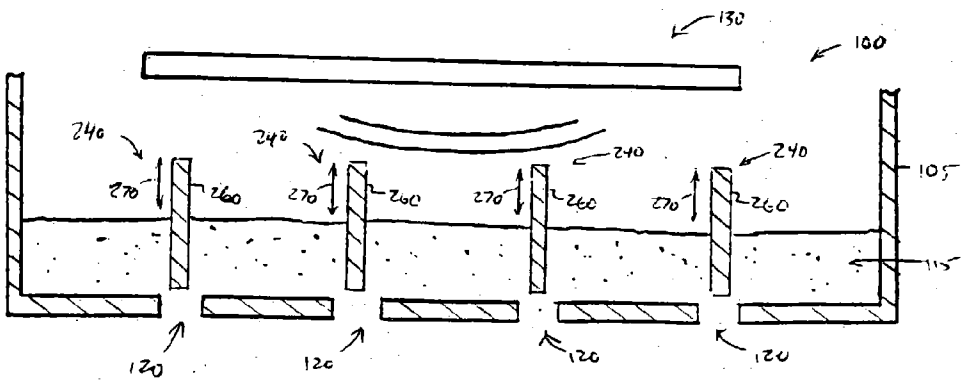

Figure 8B

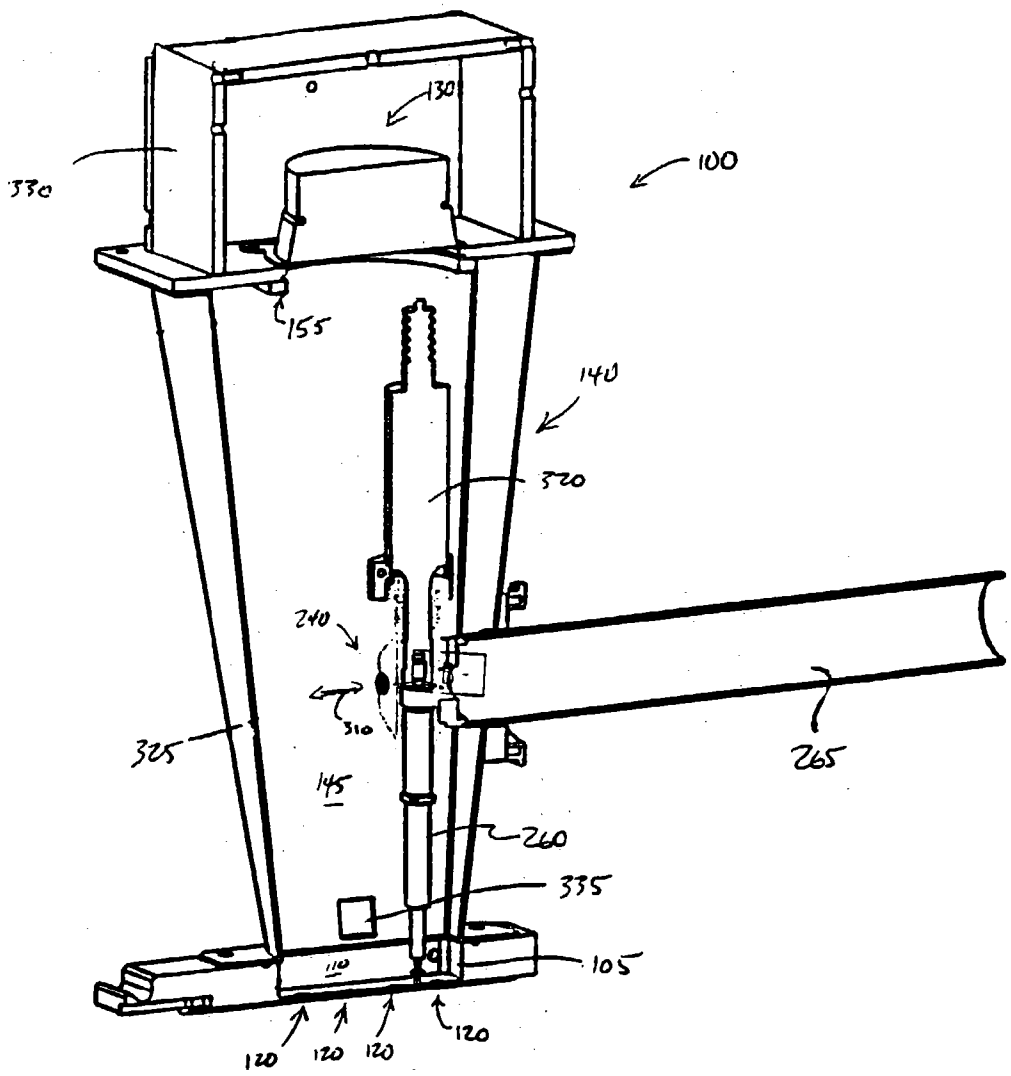

Figure 9

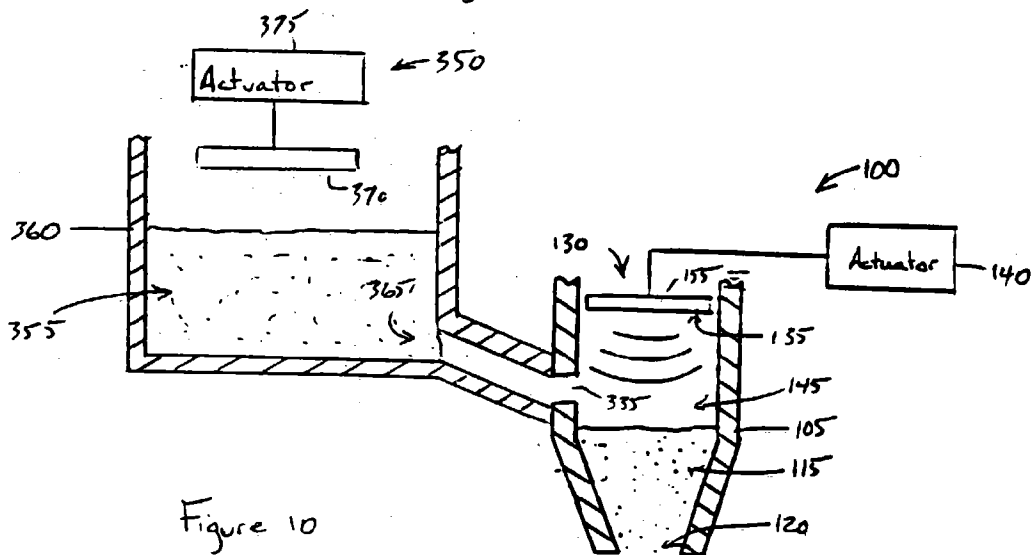

Figure 10

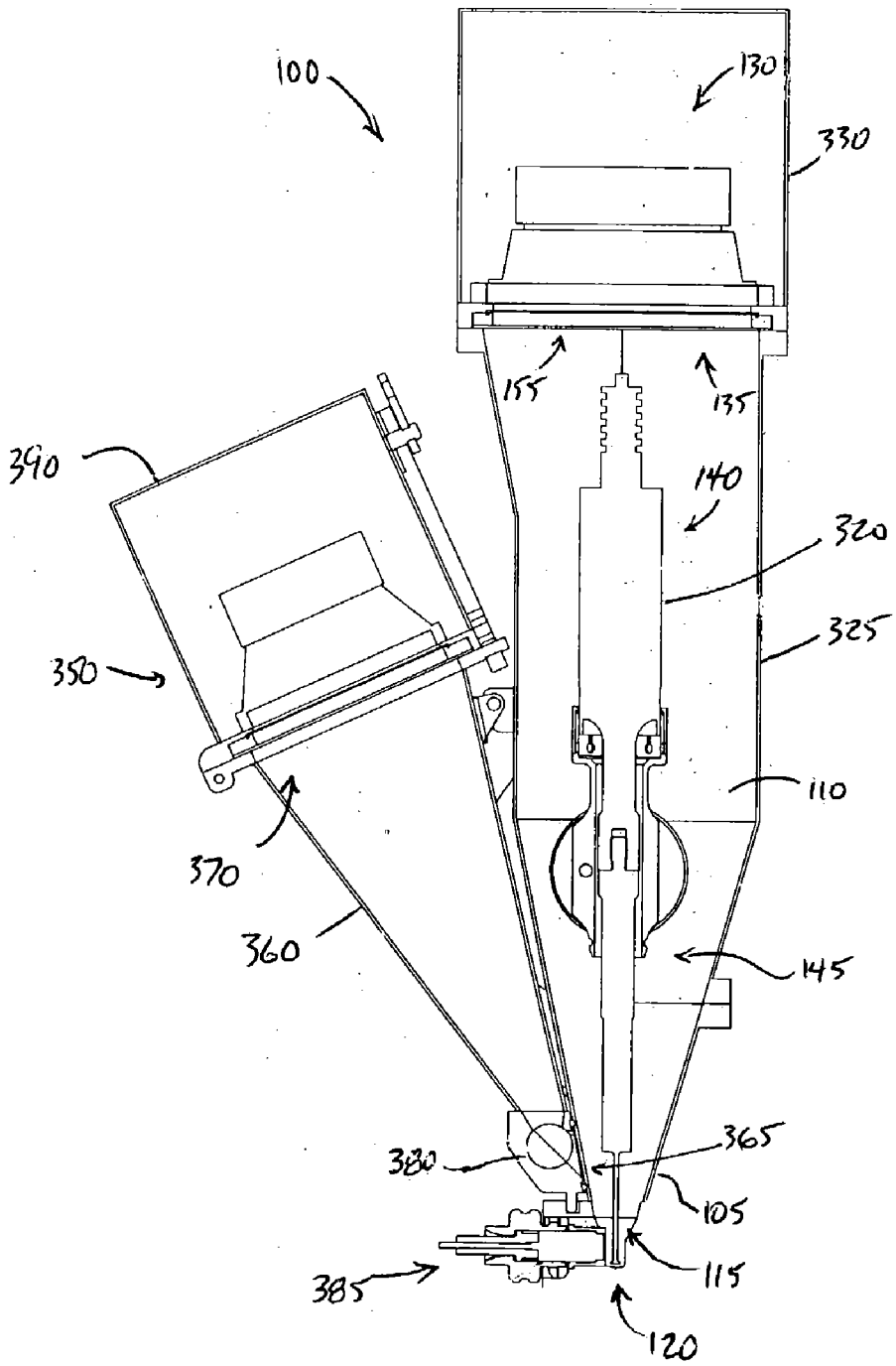

Figure 11

CONTROLLING THE FLOW OF A POWDER

[0001] This application claims the benefit of U.S. Provisional Patent Application Serial No. 60/392,076, filed on Jun. 27, 2002, which is incorporated herein by reference in its entirety.

BACKGROUND

[0002] The need for effective therapeutic treatment of patients has resulted in the development of a variety of techniques for delivering a pharmaceutical formulation to a patient. One traditional technique involves the oral delivery of a pharmaceutical formulation in the form of a pill, capsule, or the like. Inhaleable drug delivery, where an aerosolized pharmaceutical formulation is orally or nasally inhaled by a patient to deliver the formulation to the patient's respiratory tract, has also proven to be an effective manner of delivery. In one inhalation technique, a pharmaceutical formulation is delivered deep within a patient's lungs where it may be absorbed into the blood stream. In another inhalation technique, a pharmaceutical formulation is delivered to a targeted region in the respiratory tract to provide local treatment to the region. Many types of inhalation devices exist including devices that aerosolize a dry powder pharmaceutical formulation.

[0003] The pharmaceutical formulation is often packaged so that it may be made easily available to a user. For example, a dose or a portion of a dose may be stored between layers of a multi-layered package, conventionally referred to as a blister or blister pack. Typically, a cavity is formed in a lower layer, the pharmaceutical formulation is deposited within the cavity, and an upper layer is sealed onto the lower layer, such as by heating and/or compressing the layers, to secure the pharmaceutical formulation within the cavity. Alternatively, the dose may be stored in a capsule that is to be swallowed or from which the pharmaceutical formulation may be aerosolized. Other packages, such as bottles, vials, and the like, may also be used to store the pharmaceutical formulation.

[0004] It is often difficult to effectively fill packages with the pharmaceutical formulation. For example, during a powder filling process, it is difficult to sufficiently fluidize the powder and/or to maintain consistent flow properties of the powder. Poorly controlled powder flow can result in inconsistently filled packages. For example, the fill mass may vary from package to package thereby affecting the dose to be delivered to a patient for a unit dose package or resulting in too many or too few doses being packaged in a multi-dose package. Additionally, the packing characteristics of a powder in a package may vary as a result of inconsistent powder flow during the filling process.

[0005] Therefore, it is desirable to be able to control the flow of a powder, particularly a powder pharmaceutical formulation. It is further desirable to be able to control the flow of a powder pharmaceutical formulation so that a package may be effectively and consistently filled with the pharmaceutical formulation. It is still further desirable to control the flow of a pharmaceutical formulation in a manner that reduces any adverse effects on the pharmaceutical formulation.

SUMMARY

[0006] The present invention satisfies these needs. In one aspect of the invention the flow of powder from a hopper is controlled in an improved manner.

[0007] In another aspect of the invention, an apparatus for filling a chamber comprises a hopper adapted to contain a powder pharmaceutical formulation, the hopper comprising an outlet. The apparatus also comprises a disturbance member capable of disturbing a medium within the hopper, the disturbance of the medium being sufficient to control the flow of powder through the outlet. The chamber may be filled by powder flowing through the outlet and into the chamber.

[0008] In another aspect of the invention, an apparatus for filling a chamber comprises a hopper adapted to contain a powder pharmaceutical formulation, the hopper comprising an outlet. The apparatus also comprises a vibratable member positioned in, on, or near the hopper so that the vibratable member is spaced from powder in the hopper, the vibratable member being capable of fluidizing the powder in the hopper. The chamber may be filled with powder flowing through the outlet and into the chamber.

[0009] In another aspect of the invention, a method of filling a chamber comprises providing a powder pharmaceutical formulation in a hopper; disturbing a medium in the hopper to fluidize the powder; and passing the powder through an outlet and into the chamber.

[0010] In another aspect of the invention, a method of filling a chamber comprises providing a powder pharmaceutical formulation; vibrating a member spaced from the powder to fluidize the powder; and passing the powder through an outlet and into the chamber.

[0011] In another aspect of the invention, a pharmaceutical package is made by a process comprising providing a receptacle; filling the receptacle with a powder pharmaceutical formulation that has been fluidized by a fluidization member spaced from the powder; and sealing the receptacle to secure the powder pharmaceutical formulation therein.

DRAWINGS

[0012] These features, aspects, and advantages of the present invention will become better understood with regard to the following description, appended claims, and accompanying drawings which illustrate exemplary features of the invention. However, it is to be understood that each of the features can be used in the invention in general, not merely in the context of the particular drawings, and the invention includes any combination of these features, where:

[0013] FIG. 1 is a schematic sectional side view of a powder filling apparatus of the invention;

[0014] FIGS. 2A through 2C are schematic sectional side views of various receptacles that may be filled using the powder filling apparatus of the invention;

[0015] FIG. 3 is a schematic sectional side view of another version of a powder filling apparatus;

[0016] FIGS. 4A and 4B are schematic sectional side views of the operation of another version of a powder filling apparatus;

[0017] FIG. 5 is a schematic sectional side view of another version of a powder filling apparatus;

[0018] FIGS. 6A and 6B are schematic sectional side views of the powder filling apparatus of FIG. 5 during a powder filling process;

[0019] FIG. 7 is a schematic sectional front view of a multiple chamber powder filling apparatus;

[0020] FIGS. 8A and 8B are schematic sectional front views of other versions of multiple chamber powder filling apparatus;

[0021] FIG. 9 is a schematic cut-away view showing the interior of a version of a powder filling apparatus;

[0022] FIG. 10 is a schematic sectional side view of a powder filling apparatus together with a bulk powder container; and

[0023] FIG. 11 is a more detailed schematic sectional side view of a version of a powder filling apparatus with a bulk powder container.

DESCRIPTION

[0024] The present invention relates to controlling the flow of a powder, such as by controlling the flow of powder during a package filling process. Although the process is illustrated in the context of packaging a powder pharmaceutical formulation, the present invention can be used in other processes and should not be limited to the examples provided herein.

[0025] A powder filling apparatus 100 according to the present invention is shown schematically in FIG. 1. The powder filling apparatus 100 comprises a hopper 105 having a reservoir 110 capable of containing a bed of powder 115, such as a powder pharmaceutical formulation. The hopper 105, which may be of any suitable size and shape, comprises an outlet 120 through which fluidized powder may flow. A chamber 125 may be positioned in proximity to the outlet 120 so that powder flowing through the outlet 120 will flow into the chamber 125 to fill the chamber 125.

[0026] A powder fluidizer 130 may be positioned in, on, or near the hopper 105. The powder fluidizer 130 comprises a disturbance member 135 that provides a disturbance within the hopper 105. In one version, the disturbance member 135 may be actuated by an actuator 140 to cause a disturbance within the hopper 105 to control the flow of powder 115 in the hopper 105. For example, the disturbance member 135 may disturb a medium 145, such as air or other gas, that is in the hopper 105 in such a manner that the disturbed medium 145 may cause fluidization of the powder 115. Accordingly, at least a portion of the disturbance member 135 may be positioned so that it is separated from the powder 115 by the medium 145.

[0027] The powder fluidizer 130 may be used to control a powder filling process within the hopper 105. In one version, the powder fluidizer 130 may operate continuously or periodically in short intervals to maintain the powder 115 in a constantly fluidized state. In this version, powder 115 may flow through the outlet 120 until the hopper 105 is empty or until the chamber 125 is filled. In another version, the powder fluidizer 130 may control the timing of the flow of powder 115 and/or may control the amount of powder 115 that flows through the outlet 120 of the hopper 105 and into the chamber 125. For example, the outlet 120 in the hopper 105 may be sufficiently small that undisturbed powder 115 does not flow through the outlet 120 or does not consistently flow through the outlet 120. When it is desired for the powder 115 to flow into the chamber 125, the actuator 140

causes the disturbance member 135 to disturb the medium 145 and thereby fluidize the powder 115 to allow the powder 115 to flow through the outlet 120 and into the chamber 125. When the chamber 125 is sufficiently filled, the actuator 140 may cause the disturbance to stop or be reduced, thereby reducing the amount of powder 115 flowing through the outlet 120, for example by terminating the flow of powder through the outlet 120.

[0028] In one version, the powder fluidizer 130 provides a disturbance within the hopper 105, and the disturbance comprises vibrations 150. The disturbance member 135 may comprise a vibratable object, such as a membrane 155, within, on or near the hopper 105, the membrane 155 being capable of vibrating when excited by the actuator 140 to produce vibrations. The vibrating membrane 155 disturbs the medium 145. For example, as the membrane 155 moves in a downward direction, the portion of the medium 145 immediately in front is compressed causing a slight increase in pressure, it then moves back past its rest position and causes a reduction in the pressure. The process may continue so that one or more waves of alternating high and low pressure are radiated away from the membrane 155. The waves contact the powder 115 and the resulting impact is sufficient to at least momentarily fluidize the powder 115.

[0029] The frequency of the vibrations 150 may be selected to fluidize a particular powder 115 and/or to best suit a particular filling process. In one particular version, the vibrations 150 may be in the audible range. In yet another version, the membrane 155 may vibrate at a frequency in a non-audible range to lessen operator annoyance. The vibration may be at any frequency, or multiple frequencies, that desirably fluidizes or otherwise controls the flow of the powder 115. For example, in the version shown in FIG. 1, the membrane 155 may vibrate at one or more frequencies comprising a frequency of from about 10 Hz to about 1000 Hz, more preferably from about 90 Hz to about 500 Hz, more preferably from about 100 Hz to about 200 Hz, and most preferably at about 120 Hz. In one version, the frequency may be selectable. For example, through experimentation or modeling, a particularly desirable frequency for a particular configuration and/or powder may be selected, such as a frequency that is determined through experimentation or analysis to cause a resonance within the hopper 105.

[0030] The chamber 125 comprises an opening 160 positionable in relation to the outlet 120 in the hopper 105 to receive powder flowing from the hopper 105 through the outlet 120. In one version, such as the version shown in FIG. 1, the opening 160 into the chamber 125 is substantially the same shape and size and as the outlet 120 to prevent excessive amounts of powder 115 from getting trapped between the hopper 105 and a member 165 that contains or supports the chamber 125. As also shown in the version of FIG. 1, the hopper 105 may comprise converging side walls 170 that provide a convergent flow path towards the outlet 120 for the powder 115. The convergent flow path allows for increased reservoir volume in the hopper 105. In another version, the chamber opening 160 and the outlet 120 may be differently sized. For example, the outlet 120 may be smaller than the opening 160 when it is desirable to fill a relatively large chamber with a precisely controlled amount of powder 115 or when it is not desirable to provide a mechanism for precisely positioning the chamber 125 beneath the outlet

120. Alternatively, the opening **160** may be smaller than the outlet **120** when it is desirable to use the hopper **105** to fill varying sizes of chambers **125** or in situations where the loss of powder **115** to spaces between the hopper **105** and the member **165** is not of critical concern.

[0031] The chamber **125** may be within a receptacle **175** used to store the powder **115**. For example, the receptacle **175** may be in the form of primary or secondary packaging used to store a powder pharmaceutical formulation. In one version, the receptacle **175** comprises a multi-layered package, conventionally referred to as a blister or blister pack, and the chamber **125** is within the multi-layered package. As shown in **FIG. 2A**, powder **115** flows from the hopper **105** to a cavity **180** in a lower layer **185** of the multi-layered package. An upper layer (not shown) may then be sealed onto the lower layer **185**, such as by heating and/or compressing the layers, to secure the powder within the cavity **180**, as described for example in U.S. Pat. No. 5,865,012 and in U.S. patent application Ser. No. 10/301,820, filed on Nov. 20, 2002, both of which are incorporated herein by reference in their entireties. In one version, the multi-layered package may comprise a lower layer comprising a metal containing layer, such as a layer comprising aluminum, and/or an upper layer comprising a metal containing layer. The metal containing layers may be sufficiently thick to substantially prevent a significant amount of moisture from passing therethrough. For example, the metal containing layers may be from about 10 μm to about 100 μm , and more preferably from about 20 μm to about 80 μm . The lower layer and the upper layer may be sealed together by a layer of sealing material, such as a layer of lacquer that may be from about 1 μm to about 20 μm . In another version, the receptacle **175** comprises a capsule, such as a capsule that is to be swallowed or from which the pharmaceutical formulation may be aerosolized, and the chamber **125** is within the capsule. As shown in **FIG. 2B**, a first portion **190** of a capsule is positioned to receive powder flowing through the outlet **120** of the hopper. After filling, a second portion (not shown) may be placed over the first portion **190** to form the a capsule shape and to contain the powder within the capsule, as described in U.S. Pat. No. 4,247,066, U.S. Pat. No. 4,864,876, U.S. Pat. No. 6,357,490, and in the PCT application WO 00/07572 published on Feb. 17, 2000, all of which are incorporated herein by reference in their entireties. In another version, as shown in **FIG. 2C**, the chamber **125** may be within a container **195**, such as a bottle, vial or the like. For example, in this version, the container **195** may be used to contain multiple doses of a powder pharmaceutical formulation, such as a container described in U.S. Pat. No. 4,524,769 which is incorporated herein by reference in its entirety.

[0032] In another version, the chamber **125** may be a transfer chamber **200** that transfers powder that flows from the hopper **115** into the transfer chamber **200** to another chamber, such as a chamber within a package **175**. For example, as shown in **FIG. 3**, the transfer chamber **200** may be provided in a movable member **205**. The transfer chamber **200** receives powder from the hopper **115** when in a filling position as shown in **FIG. 3**. The movable member **205** then transports the transfer chamber **200** to a position in proximity to the package **175** where at least a portion of the contents of the transfer chamber **200** may be emptied into the package **175**. The transport chamber **200** may be sized so that it contains a predetermined amount of powder. For

example, the transport chamber **200** may be sized to collect a dose of a powder pharmaceutical formulation, and the accurate dose may be delivered to the package **175**. A doctor blade **210** may be provided to scrape off any excess powder in the transport chamber **200**.

[0033] In the version shown in **FIGS. 4A and 4B**, a powder transfer assistance mechanism **215** is provided. In one version, the powder transfer assistance mechanism **215** comprises a channel **220** in communication with the transfer chamber **200**. The channel **220** is connectable to a source of suction when the transfer chamber **200** is in the powder collecting position shown in **FIG. 4A**. In this way, suction **225** can be provided to the transfer chamber **200** to assist in collecting powder **115** within the transfer chamber **200**. A filter **230** may be provided in the transfer chamber **200** to prevent powder **115** from being suctioned into the channel **220**. For example, the filter may comprise apertures having a diameter of from about 0.10 micrometers to about 0.65 micrometers, most preferably about 0.65 micrometers. When the transfer chamber **200** is moved to a powder ejecting position as shown in **FIG. 4B**, the channel **220** may be connectable to a source of pressurized gas to create pressure **235** within the channel **220** to cause the powder in the transfer chamber **200** to be ejected into the receptacle **175**. An example of a powder transfer assistance mechanism is described in U.S. Pat. No. 5,826,633, which is incorporated herein by reference in its entirety.

[0034] The powder filling apparatus **100** provides for an advantageous powder filling process. One such advantage is that there is a reduction in the amount of physical contact between powder in the hopper **105** and other objects. This reduced contact can be useful in preventing undesirable conditions in the powder pharmaceutical formulation. For example, excessive physical contact can in some situations cause one or more of the following situations: formation of aggregates, increased electrostatic interactions, denaturation, and reduced aerosol performance. Though these undesirable effects have been prevented or compensated for in costly and encumbering manners, the reduction of the amount of direct physical contact provides a particularly simplified and useful alternative.

[0035] In another version, the powder filling apparatus **100** comprises a powder fluidizer **130** of the type discussed above in combination with an additional powder fluidizing member. For example, as shown in **FIG. 5**, the powder filling apparatus may comprise a second powder fluidizer **240**. The second powder fluidizer **240** comprises a powder fluidizing member **250** and an actuator **255** that drives the powder fluidizing member **250** to in a manner that fluidizes the powder **115** in the hopper **105**. For example, the powder fluidizing member **250** may be a member that directly contacts the powder **115**, and the movement of the fluidizing member **250** causes the powder **115** to fluidize. In the version shown, the powder fluidizing member **250** comprises a rod **260** that extends downwardly into the bed of powder **115**. A holding arm **265** holds the rod **260** in the hopper **105**. The actuator **255** may be connected to drive the arm **265** to drive the rod **260** or may be connected directly to the rod **260**, such as by being connected between the rod **260** and the arm **265**. The fluidization of powder in this manner is described in U.S. Pat. No. 6,182,712 which is incorporated herein by reference in its entirety. The rod **260** may be caused to vibrate by the actuator **240**. For example,

as shown in FIG. 5, the rod may have a distal end that is positionable near the outlet 120, and the actuator 240 may drive the rod in an up and down motion 270 to fluidize the powder to cause it to flow through the outlet 120 and into the chamber 125. In one particular version, the rod 260 may be attached to a motor, such as a piezoelectric motor, and is vibrated at a frequency of from about 1000 Hz to about 180,000 Hz, more preferably from about 10,000 Hz to about 40,000 Hz, and most preferably from about 15,000 Hz to about 25,000 Hz. Additionally or alternatively, the rod 260 may be vibrated or moved in another direction, such as laterally or rotationally. In another version, the additional powder fluidizing member may comprise a stirrer or other fluidizing mechanism.

[0036] The powder fluidizer 130 and second powder fluidizer 240 may work in tandem or alone to fluidize powder 115 in the hopper 105. For example, as shown in FIG. 5, the powder fluidizer 130 may be actuated concurrently with the second powder fluidizer 240 to simultaneously generate vibrations 150 in the medium 145 and to directly vibrate 270 the powder 115. For some powders this combined action provides superior fluidization capabilities. In another version, the powder fluidizer 130 and the second powder fluidizer 240 may be actuated at different times or actuated in a manner to supplement one another. For example, as shown in FIGS. 6A and 6B, the powder fluidizer 130 may serve to supplement the action of the second powder fluidizer 240. As shown in FIG. 6A, for some powders, the vibration of the rod 260 may be sufficient for a chamber 125 to be filled but may also result in the formation of one or more voids 275 in the area in proximity to the rod 260. After the void 275 has been created, vibration of the rod 260 would have little fluidization capability. To fill the void 275, the powder fluidizer 130 may be actuated, as shown in FIG. 6B. The disturbance to the medium 145 is sufficient to cause the powder 115 to again contact the rod 260 so that the rod 260 may again be vibrated to fluidize the powder 115. The powder fluidizer 130 and/or the second powder fluidizer 240 may operate continuously to maintain the powder 115 in a continuously fluidized condition during the filling of multiple chambers 125 through the outlet 120. Alternatively, the powder fluidizer 130 and/or the second powder fluidizer 240 may operate only when it is desired to have the powder 115 fluidized, and the outlet 120 may be sized such that the powder does not substantially flow through the outlet 120 in the absence of such operation of the fluidizers.

[0037] In one version, as shown in FIG. 7, the powder filling apparatus 100 is configured to simultaneously fill a plurality of chambers 125. In this version the hopper 105 comprises a plurality of outlets 120, such as two, three, four, or more. The powder fluidizer 130 is positioned to fluidize the powder 115 in the hopper 105 across all of the outlets 120. In the version shown in FIG. 7, the powder flowing through an outlet 120 passes into a transfer chamber 200 in a moveable member 205, which in this version is a rotatable member. When the transfer chamber 200 is filled, the moveable member 205 is rotated from the filling position shown in the figure to an ejecting position where the transfer chambers 200 are positioned above respective receptacles 175. The receptacles 175 are supported by a platform 300. The platform 300 may be moveable relative to the moveable member 205 so as to be able to bring the receptacles 175 into the position shown in FIG. 7 and to take the receptacles 175 away after they are filled, at which time the transfer cham-

bers 200 are moved back to their filling positions. This process may continue until a desired number of receptacles have been filled. In one version, the platform 300 may be a moveable and indexable plate having openings for receiving receptacles. In another version, the platform 300 may be a belt on a roller system.

[0038] FIGS. 8A and 8B show versions of a powder filling apparatus 100 capable of simultaneously filling a plurality of chambers 120 and comprising a powder fluidizer 130 and a second powder fluidizer 240. In the version of FIG. 8A, the second powder fluidizer 240 comprises a rod 260 that may be vibrated in an up and down direction 270. In addition, a mechanism is provided that allows the rod 260 to translate laterally 310 across each of the openings. An exemplary translation mechanism is described in aforementioned U.S. Pat. No. 6,182,71.2 which is incorporated herein by reference, as discussed above. In the version of FIG. 8B, a plurality of vibrating rods 260 are provided. For example, a rod 260 may be associated with a respective outlet 120.

[0039] A detailed view of an embodiment of a powder filling apparatus in accordance with the version of FIG. 8A is shown in FIG. 9. In this version, a powder fluidizer 130 and a second powder fluidizer 240 are used to control the flow of powder in the hopper through a plurality of outlets 120. The rod 260 of the second powder fluidizer is connected to a piezoelectric actuator or motor 320 to cause the rod 260 to vibrate up and down. A mechanism, such as a screw drive, is provided within the arm 265 that causes the rod 260 to translate 310 across the hopper 105. A first enclosure 325 and a second enclosure 330 are provided to maintain desirable conditions within the powder filling apparatus 100. For example, for some powders, such as powder pharmaceutical formulations, it may be desirable to maintain a clean or sterile environment for the powder. It may also be desirable to maintain a certain relative humidity within enclosures, particularly when filling powders that undergo a change when subjected to significant amounts of moisture. One or more of the enclosures may comprise, for example, a medical grade stainless steel, engineering polymer, PVC, or the like. In one version, multiple powder fluidizers 130 may be provided within the second enclosure. This may be advantageous when very large hoppers 105 are utilized. An inlet 335 through the enclosure 325 allows for the introduction of bulk powder into the hopper 105.

[0040] At least a portion of the powder fluidizer 130 may be housed within the second enclosure 330. In one version, the membrane 155 may be a portion of a speaker cone from a conventional audio speaker. The speaker is connected to a function generator that can provide power and frequency ranges to the speaker through an amplifier. As the speaker cone vibrates, fluidizing sound is created. The speaker cone may comprise, for example, a 3 inch woofer, a 4 inch woofer, a 6.5 inch woofer, or the like. In another version, the powder fluidizer may comprise a membrane that is spaced from the speaker cone so that when the speaker cone vibrates, the membrane is caused to vibrate. This configuration may be useful in maintaining a controlled environment within the hopper 105 in that the speaker may be housed completely within the second enclosure 330 and is not directly exposed to the hopper 105.

[0041] Additionally or alternatively, a bulk powder fluidizer 350 may be provided to fluidize bulk powder 355

contained in a bulk powder container **360**. The bulk powder container **360** may be used to supply powder to the hopper **105**, as shown in **FIG. 10**. In this version, the bulk powder container **360** comprises an outlet **365** that is in communication with the inlet **335** into the hopper **105**. The bulk powder fluidizer **350**, which may comprise a membrane **370** and actuator **375** similar to those described above, is actuated when it is desired to fluidize the bulk powder **355** to cause it to flow through the outlet **365** and into the hopper **105**. This actuation may be continuous so that a small amount of powder is continuously being supplied to the hopper **105** at about the rate that powder is flowing through the one or more outlets **120** in the hopper **105**. Alternatively, the actuation may be periodic. In one version, the bulk powder fluidizer **350** may be actuated when the level of the powder in the hopper **105** falls below a predetermined level. This may involve manual actuation or a level sensor, such as a capacitive sensor, may be provided to allow for automatic refilling. A gate or valve may also be provided near the inlet **335**.

[0042] A powder filling apparatus **100** incorporating the features of the version of **FIGS. 9 and 10** is shown in **FIG. 11**. In this version, a valve **380**, is provided to selectively introduce powder for the bulk powder container **360** into the hopper **115**. In this version, the valve **380** is opened when the level of the powder bed **115** in the hopper **105** falls below a predetermined level. The bed level is detected by a capacitive sensor **385** operatively positioned to generate a signal when the bed level falls below the predetermined height. The signal is provided to a controller which controls the opening and closing of the valve **380**. Alternatively or additionally, a laser sensor may be utilized. In the version shown, a second enclosure **390** is also provided for at least a portion of the bulk powder fluidizer **350**.

[0043] The powder filling apparatus **100** has been found to fill powder into receptacles in an improved manner. The powder filling apparatus **100** is particularly effective in filling fine dry powders into unit dose receptacles. For example, Table 1 shows a comparison of filling a fine dry, powder pharmaceutical formulation, Powder A, using a prior art powder filler and using a powder filling apparatus **100** according to the present invention. The prior art powder filler is described in U.S. Pat. No. 6,182,712. The powder filling apparatus **100** shown in present **FIG. 11** with a transfer chamber as shown in **FIGS. 4A and 4B** was used for the comparison. In the Table, N represents the number of receptacles filled; SD represents the standard deviation; and RSD represents the relative standard deviation. As can be seen, in each of five separate runs, the prior art system was unable to match the filling consistency of the powder filling apparatus **100**. In fact, in even the best run using the prior art system, the filling range was more than twice the range using the powder filling apparatus **100** of the present invention.

TABLE 1

Filler Used	N	SD (mg)	RSD (%)	Mean Fill Mass (mg)	Range (mg)
Prior Art Powder Filler, Run 1	404	0.11	1.5	7.52	1.2
Prior Art Powder Filler, Run 2	264	0.18	2.5	7.55	1.94
Prior Art Powder Filler, Run 3	491	0.16	2.1	7.52	1.11
Prior Art Powder Filler, Run 4	488	0.15	2.0	7.51	1.39
Prior Art Powder Filler, Run 5	356	0.32	4.3	7.50	1.99
Present Powder Filler 100	288	0.08	1.1	7.50	0.55

[0044] The powder filling apparatus **100** of the present invention has also shown universal adaptability for filling various powders. The powder filling apparatus **100** shown in present **FIG. 11** with a transfer chamber as shown in **FIGS. 4A and 4B** was used for a comparison of different powders, and the results are shown in Table 2. Six different powders were filled into unit dose receptacles. The powders were of varying size, compositions, active agents, excipients, and properties. However, as can be seen from the data, very consistent filling was achieved with each of the powders. Very low RSD's were achieved for each of the powders. In addition, the powder filling apparatus **100** demonstrated the ability to consistently fill both small and large doses into a receptacle.

TABLE 2

Powder Filled Using Present Powder Filler 100	N	SD (mg)	RSD (%)	Mean Fill Mass (mg)	Range (mg)
Powder A	288	0.08	1.1	7.50	0.59
Powder B	120	0.03	0.9	4.06	0.16
Powder C	60	0.06	1.2	4.90	0.28
Powder D	270	0.91	1.8	50.09	4.90
Powder E	89	0.55	1.1	51.32	3.04
Powder F	30	0.18	1.8	10.09	0.82

[0045] A computer controller may be provided to control the actuation of the bulk powder fluidizer **350** and/or to control the actuation of the powder fluidizer **130** and/or the second powder fluidizer **240**. The controller may control the operation of the entire powder filling apparatus **100**. The controller may be a single controller device or may be a plurality of controller devices that may be connected to one another or a plurality of controller devices that may be connected to different components of the packaging apparatus **100**.

[0046] In one embodiment, the controller comprises electronic hardware including electrical circuitry comprising integrated circuits that is suitable for operating or controlling the powder filling apparatus **100**. Generally, the controller is adapted to accept data input, run algorithms, produce useful output signals, and may also be used to detect data signals from one or more sensors and other device components, and to monitor or control the process in the powder filling apparatus **100**. However, the controller may merely perform one of these tasks. In one version, the controller may comprise one or more of (i) a computer comprising a central processor unit (CPU) which is interconnected to a memory system with peripheral control components, (ii) application specific integrated circuits (ASICs) that operate particular components of the powder filling apparatus **100** or operate a particular process, and (iii) one or more controller interface boards along with suitable support circuitry. Typical CPUs include the PowerPC™, Pentium™, and other such processors. The ASICs are designed and preprogrammed for particular tasks, such as retrieval of data and other information from the powder filling apparatus **100** and/or operation of particular device components. Typical support circuitry includes for example, coprocessors, clock circuits, cache, power supplies and other well known components that are in communication with the CPU. For example, the CPU often operates in conjunction with a random access memory (RAM), a read-only memory (ROM) and other storage

devices well known in the art. The RAM can be used to store the software implementation of the present invention during process implementation. The programs and subroutines of the present invention are typically stored in mass storage devices and are recalled for temporary storage in RAM when being executed by the CPU.

[0047] The software implementation and computer program code product of the present invention may be stored in a memory device, such as an EPROM, and called into RAM during execution by the controller. The computer program code may be written in conventional computer readable programming languages, such as for example, assembly language, C, C++, Pascal, or native assembly. Suitable program code is entered into a single file, or multiple files, using a conventional text editor and stored or embodied in a computer-usable medium, such as a memory of the computer system. If the entered code text is in a high level language, the code is compiled to a compiler code which is linked with an object code of precompiled windows library routines. To execute the linked and compiled object code, the system user invokes the object code, causing the computer system to load the code in memory to perform the tasks identified in the computer program.

[0048] In one version, the controller may comprise a microprocessor or ASIC of sufficiently small size and power consumption to be housed on or in the powder filling apparatus **100**. For example, suitable microprocessors for use as a local microprocessor include the MC68HC711E9 by Motorola, the PIC16C74 by Microchip, and the 82930AX by Intel Corporation. The microprocessor can include one microprocessor chip, multiple processors and/or co-processor chips, and/or digital signal processor (DSP) capability.

[0049] In one particularly useful implementation, the powder filling apparatus **100** may be used to fill a pharmaceutical receptacle, such as a blister, capsule, vial, bottle, or the like, with a powder pharmaceutical formulation. For example, the powder filling apparatus **100** has proven to be particularly advantageous in filling dry powder inhaleable pharmaceutical formulations into receptacles from which the pharmaceutical formulation may be aerosolized for inhalation by a user. For example, when in a powdered form, the powder may be initially stored in the sealed package, which is opened prior to aerosolization of the powder, as described in U.S. Pat. No. 5,785,049, U.S. Pat. No. 5,415,162, and U.S. patent application Ser. No. 09/583,312. Alternatively the powder may be contained in a capsule, as described in U.S. Pat. No. 4,995,385, U.S. Pat. No. 3,991,761, U.S. Pat. No. 6,230,707, and PCT Publication WO 97/27892, the capsule being openable before, during, or after insertion of the capsule into an aerosolization device. In either the bulk, blister, capsule, or the like form, the powder may be aerosolized by an active element, such as compressed air, as described in U.S. Pat. No. 5,458,135, U.S. Pat. No. 5,785,049, and U.S. Pat. No. 6,257,233, or propellant, as described in U.S. patent application Ser. No. 09/556,262, filed on Apr. 24, 2000, and entitled "Aerosolization Apparatus and Methods", and in PCT Publication WO 00/72904. Alternatively the powder may be aerosolized in response to a user's inhalation, as described for example in the aforementioned U.S. patent application Ser. No. 09/583,312 and U.S. Pat. No. 4,995,385. All of the above references being incorporated herein by reference in their entireties.

[0050] The pharmaceutical formulation may comprise an active agent. The active agent described herein includes an agent, drug, compound, composition of matter or mixture thereof which provides some pharmacologic, often beneficial, effect. This includes foods, food supplements, nutrients, drugs, vaccines, vitamins, and other beneficial agents. As used herein, the terms further include any physiologically or pharmacologically active substance that produces a localized or systemic effect in a patient. An active agent for incorporation in the pharmaceutical formulation described herein may be an inorganic or an organic compound, including, without limitation, drugs which act on: the peripheral nerves, adrenergic receptors, cholinergic receptors, the skeletal muscles, the cardiovascular system, smooth muscles, the blood circulatory system, synaptic sites, neuroeffector junctional sites, endocrine and hormone systems, the immunological system, the reproductive system, the skeletal system, pulmonary system, autacid systems, the alimentary and excretory systems, the histamine system, and the central nervous system. Suitable active agents may be selected from, for example, hypnotics and sedatives, psychic energizers, tranquilizers, respiratory drugs, anticonvulsants, muscle relaxants, antiparkinson agents (dopamine antagonists), analgesics, anti-inflammatories, antianxiety drugs (anxiolytics), appetite suppressants, antimigraine agents, muscle contractants, anti-infectives (antibiotics, antivirals, antifungals, vaccines) antiarthritics, antimalarials, antiemetics, antiepileptics, bronchodilators, cytokines, growth factors, anti-cancer agents, antithrombotic agents, antihypertensives, cardiovascular drugs, antiarrhythmics, antioxidants, anti-asthma agents, hormonal agents including contraceptives, sympathomimetics, diuretics, lipid regulating agents, antiandrogenic agents, antiparasitics, anticoagulants, neoplastics, antineoplastics, hypoglycemics, nutritional agents and supplements, growth supplements, antienteritis agents, vaccines, antibodies, diagnostic agents, and contrasting agents. The active agent, when administered by inhalation, may act locally or systemically.

[0051] The active agent may fall into one of a number of structural classes, including but not limited to small molecules, peptides, polypeptides, proteins, polysaccharides, steroids, proteins capable of eliciting physiological effects, nucleotides, oligonucleotides, polynucleotides, fats, electrolytes, and the like.

[0052] Examples of active agents suitable for use in this invention include but are not limited to one or more of calcitonin, amphotericin B, erythropoietin (EPO), Factor VIII, Factor IX, ceredase, cerezyme, cyclosporin, granulocyte colony stimulating factor (GCSF), thrombopoietin (TPO), alpha-1 proteinase inhibitor, elcatonin, granulocyte macrophage colony stimulating factor (GM-CSF), growth hormone, human growth hormone (HGH), growth hormone releasing hormone (GHRH), heparin, low molecular weight heparin (LMWH), interferon alpha, interferon beta, interferon gamma, interleukin-1 receptor, interleukin-2, interleukin-1 receptor antagonist, interleukin-3, interleukin-4, interleukin-6, luteinizing hormone releasing hormone (LHRH), factor IX, insulin, pro-insulin, insulin analogues (e.g., monoacylated insulin as described in U.S. Pat. No. 5,922,675, which is incorporated herein by reference in its entirety), amylin, C-peptide, somatostatin, somatostatin analogs including octreotide, vasopressin, follicle stimulating hormone (FSH), insulin-like growth factor (IGF), insulinotropin, macrophage colony stimulating factor (M-CSF), nerve

growth factor (NGF), tissue growth factors, keratinocyte growth factor (KGF), glial growth factor (GGF), tumor necrosis factor (TNF), endothelial growth factors, parathyroid hormone (PTH), glucagon-like peptide thymosin alpha 1, IIb/IIIa inhibitor, alpha-1 antitrypsin, phosphodiesterase (PDE) compounds, VLA-4 inhibitors, bisphosphonates, respiratory syncytial virus antibody, cystic fibrosis transmembrane regulator (CFTR) gene, deoxyribonuclease (Dnase), bactericidal/permeability increasing protein (BPI), anti-CMV antibody, 13-cis retinoic acid, macrolides such as erythromycin, oleandomycin, troleandomycin, roxithromycin, clarithromycin, davercin, azithromycin, flurithromycin, dirithromycin, josamycin, spiramycin, midecamycin, leucomycin, miocamycin, rokitamycin, andazithromycin, and swinolide A; fluoroquinolones such as ciprofloxacin, ofloxacin, levofloxacin, trovafloxacin, alatrofloxacin, moxifloxacin, norfloxacin, enoxacin, grepafloxacin, gatifloxacin, lomefloxacin, sparfloxacin, temafloxacin, pefloxacin, amifloxacin, fleroxacin, tosufloxacin, prulifloxacin, irloxacin, pazufloxacin, clinafloxacin, and sitafloxacin, aminoglycosides such as gentamicin, netilmicin, paramecin, tobramycin, amikacin, kanamycin, neomycin, and streptomycin, vancomycin, teicoplanin, rampolanin, mideplanin, colistin, daptomycin, gramicidin, colistimethate, polymyxins such as polymixin B, capreomycin, bacitracin, penems; penicillins including penicillinase-sensitive agents like penicillin G, penicillin V, penicillinase-resistant agents like methicillin, oxacillin, cloxacillin, dicloxacillin, floxacillin, nafcillin; gram negative microorganism active agents like ampicillin, amoxicillin, and hetacillin, cillin, and galampicillin; antipseudomonal penicillins like carbenicillin, ticarcillin, azlocillin, mezlocillin, and piperacillin; cephalosporins like cefpodoxime, cefprozil, ceftbuten, ceftizoxime, ceftriaxone, cephalothin, cephapirin, cephalixin, cephadrine, cefoxitin, cefamandole, cefazolin, cephaloridine, cefaclor, cefadroxil, cephaloglycin, cefuroxime, ceforanide, cefotaxime, cefatrizine, cephacetrile, cefepime, cefixime, cefonicid, cefoperazone, cefotetan, cefinetazole, ceftazidime, loracarbef, and moxalactam, monobactams like aztreonam; and carbapenems such as imipenem, meropenem, pentamidine isethionate, albuterol sulfate, lidocaine, metaproterenol sulfate, beclomethasone dipropionate, triamcinolone acetamide, budesonide acetone, fluticasone, ipratropium bromide, flunisolide, cromolyn sodium, ergotamine tartrate and where applicable, analogues, agonists, antagonists, inhibitors, and pharmaceutically acceptable salt forms of the above. In reference to peptides and proteins, the invention is intended to encompass synthetic, native, glycosylated, unglycosylated, pegylated forms, and biologically active fragments and analogs thereof.

[0053] Active agents for use in the invention further include nucleic acids, as bare nucleic acid molecules, vectors, associated viral particles, plasmid DNA or RNA or other nucleic acid constructions of a type suitable for transfection or transformation of cells, i.e., suitable for gene therapy including anti sense. Further, an active agent may comprise live attenuated or killed viruses suitable for use as vaccines. Other useful drugs include those listed within the Physician's Desk Reference (most recent edition).

[0054] The amount of active agent in the pharmaceutical formulation will be that amount necessary to deliver a therapeutically effective amount of the active agent per unit dose to achieve the desired result. In practice, this will vary widely depending upon the Particular agent, its activity, the

severity of the condition to be treated, the patient population, dosing requirements, and the desired therapeutic effect. The composition will generally contain anywhere from about 1% by weight to about 99% by weight active agent, typically from about 2% to about 95% by weight active agent, and more typically from about 5% to 85% by weight active agent, and will also depend upon the relative amounts of additives contained in the composition. The compositions of the invention are particularly useful for active agents that are delivered in doses of from 0.001 mg/day to 100 mg/day, preferably in doses from 0.01 mg/day to 75 mg/day, and more preferably in doses from 0.10 mg/day to 50 mg/day. It is to be understood that more than one active agent may be incorporated into the formulations described herein and that the use of the term "agent" in no way excludes the use of two or more such agents.

[0055] The pharmaceutical formulation may comprise a pharmaceutically acceptable excipient or carrier which may be taken into the lungs with no significant adverse toxicological effects to the subject, and particularly to the lungs of the subject. In addition to the active agent, a pharmaceutical formulation may optionally include one or more pharmaceutical excipients which are suitable for pulmonary administration. These excipients, if present, are generally present in the composition in amounts ranging from about 0.01% to about 95% percent by weight, preferably from about 0.5 to about 80%, and more preferably from about 1 to about 60% by weight. Preferably, such excipients will, in part, serve to further improve the features of the active agent composition, for example by providing more efficient and reproducible delivery of the active agent, improving the handling characteristics of powders, such as flowability and consistency, and/or facilitating manufacturing and filling of unit dosage forms. In particular, excipient materials can often function to further improve the physical and chemical stability of the active agent, minimize the residual moisture content and hinder moisture uptake, and to enhance particle size, degree of aggregation, particle surface properties, such as rugosity, ease of inhalation, and the targeting of particles to the lung. One or more excipients may also be provided to serve as bulking agents when it is desired to reduce the concentration of active agent in the formulation.

[0056] Pharmaceutical excipients and additives useful in the present pharmaceutical formulation include but are not limited to amino acids, peptides, proteins, non-biological polymers, biological polymers, carbohydrates, such as sugars, derivatized sugars such as alditols, aldonic acids, esterified sugars, and sugar polymers, which may be present singly or in combination. Suitable excipients are those provided in WO 96/32096, which is incorporated herein by reference in its entirety. The excipient may have a glass transition temperature (T_g) above about 35° C., preferably above about 40° C., more preferably above 45° C., most preferably above about 55° C.

[0057] Exemplary protein excipients include albumins such as human serum albumin (HSA), recombinant human albumin (rHA), gelatin, casein, hemoglobin, and the like. Suitable amino acids (outside of the dileucyl-peptides of the invention), which may also function in a buffering capacity, include alanine, glycine, arginine, betaine, histidine, glutamic acid, aspartic acid, cysteine, lysine, leucine, isoleucine, valine, methionine, phenylalanine, aspartame, tyrosine, tryptophan, and the like. Preferred are amino acids

and polypeptides that function as dispersing agents. Amino acids falling into this category include hydrophobic amino acids such as leucine, valine, isoleucine, tryptophan, alanine, methionine, phenylalanine, tyrosine, histidine, and proline. Dispersibility-enhancing peptide excipients include dimers, trimers, tetramers, and pentamers comprising one or more hydrophobic amino acid components such as those described above.

[0058] Carbohydrate excipients suitable for use in the invention include, for example, monosaccharides such as fructose, maltose, galactose, glucose, D-mannose, sorbose, and the like; disaccharides, such as lactose, sucrose, trehalose, cellobiose, and the like; polysaccharides, such as raffinose, melezitose, maltodextrins, dextrans, starches, and the like; and alditols, such as mannitol, xylitol, maltitol, lactitol, xylitol sorbitol (glucitol), pyranosyl sorbitol, myoinositol and the like.

[0059] The pharmaceutical formulation may also include a buffer or a pH adjusting agent, typically a salt prepared from an organic acid or base. Representative buffers include organic acid salts of citric acid, ascorbic acid, gluconic acid, carbonic acid, tartaric acid, succinic acid, acetic acid, or phthalic acid, Tris, tromethamine hydrochloride, or phosphate buffers.

[0060] The pharmaceutical formulation may also include polymeric excipients/additives, e.g., polyvinylpyrrolidones, derivatized celluloses such as hydroxymethylcellulose, hydroxyethylcellulose, and hydroxypropylmethylcellulose, Ficolls (a polymeric sugar), hydroxyethylstarch, dextrates (e.g., cyclodextrins, such as 2-hydroxypropyl- β -cyclodextrin and sulfobutylether- β -cyclodextrin), polyethylene glycols, and pectin.

[0061] The pharmaceutical formulation may further include flavoring agents, taste-masking agents, inorganic salts (for example sodium chloride), antimicrobial agents (for example benzalkonium chloride), sweeteners, antioxidants, antistatic agents, surfactants (for example polysorbates such as "TWEEN 20" and "TWEEN 80"), sorbitan esters, lipids (for example phospholipids such as lecithin and other phosphatidylcholines, phosphatidylethanolamines), fatty acids and fatty esters, steroids (for example cholesterol), and chelating agents (for example EDTA, zinc and other such suitable cations). Other pharmaceutical excipients and/or additives suitable for use in the compositions according to the invention are listed in "Remington: The Science & Practice of Pharmacy", 19th ed., Williams & Williams, (1995), and in the "Physician's Desk Reference", 52nd ed., Medical Economics, Montvale, N.J. (1998), both of which are incorporated herein by reference in their entireties.

[0062] "Mass median diameter" or "MMD" is a measure of mean particle size, since the powders of the invention are generally polydisperse (i.e., consist of a range of particle sizes). MMD values as reported herein are determined by centrifugal sedimentation, although any number of commonly employed techniques can be used for measuring mean particle size. "Mass median aerodynamic diameter" or "MMAD" is a measure of the aerodynamic size of a dispersed particle. The aerodynamic diameter is used to describe an aerosolized powder in terms of its settling behavior, and is the diameter of a unit density sphere having the same settling velocity, generally in air, as the particle.

The aerodynamic diameter encompasses particle shape, density and physical size of a particle. As used herein, MMAD refers to the midpoint or median of the aerodynamic particle size distribution of an aerosolized powder determined by cascade impaction.

[0063] In one version, the powdered formulation for use in the present invention includes a dry powder having a particle size selected to permit penetration into the alveoli of the lungs, that is, preferably 10 μm mass median diameter (MMD), preferably less than 7.5 μm , and most preferably less than 5 μm , and usually being in the range of 0.1 μm to 5 μm in diameter. The delivered dose efficiency (DDE) of these powders may be greater than 30%, more preferably greater than 40%, more preferably greater than 50% and most preferably greater than 60% and the aerosol particle size distribution is about 1.0-5.0 μm mass median aerodynamic diameter (MMAD), usually 1.5-4.5 μm MMAD and preferably 1.5-4.0 μm MMAD. These dry powders have a moisture content below about 10% by weight, usually below about 5% by weight, and preferably below about 3% by weight. Such powders are described in WO 95/24183, WO 96/32149, WO 99/16419, and WO 99/16422, all of which are all incorporated herein by reference in their entireties.

[0064] Although the present invention has been described in considerable detail with regard to certain preferred versions thereof, other versions are possible, and alterations, permutations and equivalents of the version shown will become apparent to those skilled in the art upon a reading of the specification and study of the drawings. For example, the relative positions of the elements in the expedients for carrying out the relative movements may be changed. Also, the various features of the versions herein can be combined in various ways to provide additional versions of the present invention. Furthermore, certain terminology has been used for the purposes of descriptive clarity, and not to limit the present invention. For example, the use of the terms such as "up" and "down" and "first" and "second" may be reversed in the specification. Therefore, the appended claims should not be limited to the description of the preferred versions contained herein and should include all such alterations, permutations, and equivalents as fall within the true spirit and scope of the present invention.

What is claimed is:

1. An apparatus for filling a chamber, the apparatus comprising:

a hopper adapted to contain a powder pharmaceutical formulation, the hopper comprising an outlet; and

a disturbance member capable of disturbing a medium within the hopper, the disturbance of the medium being sufficient to control the flow of powder through the outlet,

whereby the chamber may be filled by powder flowing through the outlet and into the chamber.

2. An apparatus according to claim 1 wherein the medium comprises a gas.

3. An apparatus according to claim 1 wherein the medium comprises air.

4. An apparatus according to claim 1 wherein the disturbance member is a vibratable member capable of generating vibrations within the hopper.

5. An apparatus according to claim 4 wherein the vibratable member comprises a membrane.

6. An apparatus according to claim 5 wherein the membrane is adapted to vibrate at a frequency selected to fluidize the powder.

7. An apparatus according to claim 5 wherein the membrane is adapted to vibrate at a frequency selected to cause resonance within the container.

8. An apparatus according to claim 1 wherein the vibratable member is adapted to vibrate at a frequency of from about 10 Hz to about 1000 Hz.

9. An apparatus according to claim 1 further comprising a powder vibrating member.

10. An apparatus according to claim 9 wherein the powder vibrating member comprises a member adapted to vibrate in contact with the powder.

11. An apparatus according to claim 9 wherein the powder vibrating member has a longitudinal axis and wherein the powder vibrating member vibrates in a direction parallel to the longitudinal axis.

12. An apparatus according to claim 1 wherein the chamber is a chamber in a receptacle.

13. An apparatus according to claim 12 wherein the receptacle is a blister pack.

14. An apparatus according to claim 12 wherein the receptacle is a capsule.

15. An apparatus according to claim 1 further comprising the chamber and wherein the chamber is adapted to transport the powder to a receptacle.

16. An apparatus according to claim 15 wherein the chamber is a metering chamber.

17. An apparatus according to claim 15 wherein the chamber is in a rotatable member.

18. An apparatus according to claim 17 wherein the rotatable member is rotatable between a powder receiving position and a powder ejecting position.

19. An apparatus according to claim 1 wherein the hopper comprises an enclosure having side walls.

20. An apparatus according to claim 19 wherein the hopper comprises a cover and wherein the vibratable member comprises a membrane in proximity to the cover.

21. An apparatus according to claim 19 wherein the hopper comprises a cover and wherein the cover comprises the vibratable member.

22. An apparatus for filling a chamber, the apparatus comprising:

a hopper adapted to contain a powder pharmaceutical formulation, the hopper comprising an outlet; and

a vibratable member positioned in, on, or near the hopper so that the vibratable member is spaced from powder in the hopper, the vibratable member being capable of fluidizing the powder in the hopper,

whereby the chamber may be filled with powder flowing through the outlet and into the chamber.

23. An apparatus according to claim 22 wherein the vibratable member comprises a membrane.

24. An apparatus according to claim 23 wherein the membrane is adapted to vibrate at a frequency selected to fluidize the powder.

25. An apparatus according to claim 22 further comprising a second vibratable member.

26. An apparatus according to claim 25 wherein the second vibratable member comprises a member adapted to contact the powder.

27. An apparatus according to claim 25 wherein the second vibratable member has a longitudinal axis and wherein the second vibratable member vibrates in a direction parallel to the longitudinal axis.

28. An apparatus according to claim 22 wherein the chamber comprises a receptacle.

29. An apparatus according to claim 22 further comprising the chamber and wherein the chamber is adapted to transport the powder to a receptacle.

30. An apparatus according to claim 29 wherein the chamber is a metering chamber.

31. A method of filling a chamber, the method comprising:

providing a powder pharmaceutical formulation in a hopper;

disturbing a medium in the hopper to fluidize the powder; and

passing the powder through an outlet and into the chamber.

32. A method according to claim 31 wherein the medium comprises a gas.

33. A method according to claim 31 wherein the medium comprises air.

34. A method according to claim 31 comprising disturbing the medium by generating vibrations within the medium.

35. A method according to claim 34 wherein the vibrations are generated by vibrating a membrane.

36. A method according to claim 35 wherein the membrane is adapted to vibrate at a frequency selected to fluidize the powder so that the powder will pass through the outlet.

37. A method according to claim 36 wherein the membrane is vibrated at a frequency of from about 10 Hz to about 1000 Hz.

38. A method according to claim 31 further comprising vibrating a member that is in contact with the powder.

39. A method according to claim 31 wherein the chamber comprises a receptacle and further comprising sealing the receptacle.

40. A method according to claim 31 further comprising transferring the powder from the chamber to a receptacle.

41. A method according to claim 31 comprising rotating the chamber from a powder receiving position to a powder ejecting position.

42. A method of filling a chamber, the method comprising:

providing a powder pharmaceutical formulation;

vibrating a member spaced from the powder to fluidize the powder; and

passing the powder through an outlet and into the chamber.

43. A method according to claim 42 wherein the member is a membrane.

44. A method according to claim 43 wherein the membrane is adapted to vibrate at a frequency selected to fluidize the powder so that the powder will pass through the outlet.

45. A method according to claim 42 wherein the powder is vibrated at a frequency of from about 10 Hz to about 1000 Hz.

46. A method according to claim 42 further comprising vibrating a second member, the second member being in contact with the powder.

47. A pharmaceutical package made by a process comprising:

providing a receptacle;

filling the receptacle with a powder pharmaceutical formulation that has been fluidized by a fluidization member spaced from the powder; and

sealing the receptacle to secure the powder pharmaceutical formulation therein.

48. A pharmaceutical package according to claim 47 wherein the receptacle comprises a blister package.

49. A pharmaceutical package according to claim 48 wherein the blister package comprises a lower layer comprising a cavity.

50. A pharmaceutical package according to claim 49 wherein the blister package comprises an upper layer that is sealable onto the lower layer.

51. A pharmaceutical package according to claim 50 wherein at least one of the layers comprises a metal.

52. A pharmaceutical package according to claim 50 wherein both layers comprise a metal.

53. A pharmaceutical package according to claim 47 wherein the receptacle is at least a portion of a capsule.

54. A pharmaceutical package according to claim 47 wherein the receptacle is at least a portion of vial.

55. A pharmaceutical package according to claim 47 wherein the receptacle is a bottle.

56. A pharmaceutical package according to claim 47 wherein the package is made by a process further comprising metering the powder in a metering chamber before filling the receptacle.

57. A pharmaceutical package according to claim 56 wherein the package is made by a process further comprising rotating the metering chamber.

58. A pharmaceutical package according to claim 47 wherein the package is made by a process wherein the pharmaceutical formulation is also fluidized by a vibrating member in contact with the powder.

* * * * *