

(19)



(11)

EP 3 315 736 B1

(12)

EUROPEAN PATENT SPECIFICATION

(45) Date of publication and mention of the grant of the patent:
18.12.2019 Bulletin 2019/51

(51) Int Cl.:
F01L 1/44^(2006.01)

(21) Application number: **17198441.2**

(22) Date of filing: **26.10.2017**

(54) **ENDOTHERMIC ENGINE WITH IMPROVED DISTRIBUTION SYSTEM**

ENDOTHERMER MOTOR MIT VERBESSERTEM VERTEILUNGSSYSTEM

MOTEUR ENDOTHERMIQUE À SYSTÈME DE DISTRIBUTION AMÉLIORÉ

(84) Designated Contracting States:
**AL AT BE BG CH CY CZ DE DK EE ES FI FR GB
GR HR HU IE IS IT LI LT LU LV MC MK MT NL NO
PL PT RO RS SE SI SK SM TR**

(30) Priority: **26.10.2016 IT 201600108158**

(43) Date of publication of application:
02.05.2018 Bulletin 2018/18

(73) Proprietor: **Crosetta, Luca
36027 Rosà, Vicenza (IT)**

(72) Inventor: **Crosetta, Luca
36027 Rosà, Vicenza (IT)**

(74) Representative: **Mitola, Marco
Jacobacci & Partners S.p.A.
Piazza Mario Saggin, 2
35131 Padova (IT)**

(56) References cited:
**FR-A1- 2 764 937 GB-A- 191 220 861
US-A- 1 951 759**

Remarks:

The file contains technical information submitted after the application was filed and not included in this specification

EP 3 315 736 B1

Note: Within nine months of the publication of the mention of the grant of the European patent in the European Patent Bulletin, any person may give notice to the European Patent Office of opposition to that patent, in accordance with the Implementing Regulations. Notice of opposition shall not be deemed to have been filed until the opposition fee has been paid. (Art. 99(1) European Patent Convention).

DescriptionSCOPE

[0001] The present invention relates to an internal combustion engine and aims to improve one of the most critical aspects of any internal combustion engine for which a certain amount of air, i.e. volumetric/pumping efficiency, is necessary.

[0002] In particular, in conventional engines, both Otto cycle and diesel cycle, the passage of air for combustion and its expansion is regulated by reciprocating poppet valves which, for obvious constructive and geometric reasons, generate significant bottlenecks and obstacles, thus limiting the amount of entering and exiting air, thus forcing the engine to work more for the expulsion of combustion gases.

[0003] The solution proposed in this patent has as its main scope high performance engines or high/very high-power engines where, for various reasons, both constructive and regulatory (as in the case of sporting applications), it is not possible to further increase the power delivered by means of known systems. This does not mean that the present invention may not also be applied to more conventional engines, even for non-sports applications, in order to increase the volumetric and/or pumping efficiency of the endothermic propulsion system.

PRIOR ART

[0004] As is well known, the prior art in engine applications is undoubtedly represented by the numerous sports applications where the maximum power possible is required. Depending on the formula or category, the relevant technical regulation almost always sets limits to reduce or make it more difficult to obtain high powers: limits on maximum engine displacement, cylinders, intake restrictors, maximum supercharge pressure, maximum fuel capacity, and the like. Increasing, therefore, the engine's efficiency leads an increase in the available power.

[0005] Without going too far into the details, the most commonly adopted technical solution (and at times imposed by the regulation itself, as in the case of F1) consists in the use of four valves per cylinder with a circular cross-section with alternate axial movement, actuated by a suitable distribution system that may be either a cam mechanism or, in more sophisticated cases, pneumatic, hydraulic or electrical. In the conventional engine, two valves are used for intake and two for exhaust.

[0006] High-performance engines maximize the passage area by means of high-diameter, large "raised" valves with "aggressive" phasing (wide cross phase). This all clearly has physical and constructive limits determined by the space available on the engine head (bore of the cylinder) and the structural resistance of the valves themselves, especially at high engine rotation speeds,

and thus at very high accelerations and inertias to which the same valves are subjected in the continuous inversions of rectilinear motion.

5 PRESENTATION OF THE INVENTION

[0007] In light of the foregoing, it is apparent that the known solutions, in order to increase the volumetric and pumping efficiency, employ supercharger systems which, while having a number of advantages in terms of performance, also involve a multitude of disadvantages in terms of constructive complexity, costs and tuning. The need is therefore perceived to resolve the drawbacks and limitations cited with reference to the known art. Such requirement is satisfied by an endothermic engine according to claim 1.

DESCRIPTION OF THE DRAWINGS

20 **[0008]** Further features and advantages of the present invention will become more understandable from the following description of the preferred and non-limiting embodiments thereof, wherein:

25 figure 1 represents a partial sectional view of an endothermic engine comprising a partial dual distribution intake system (DDP-A) according to a possible embodiment of the present invention;

30 figure 2 is a partial sectional view of an endothermic engine comprising a partial dual distribution exhaust system (DDP-S) according to a possible embodiment of the present invention;

35 figures 3a, 3b represent partial sectional views of an endothermic engine comprising a full dual distribution system (DDI) according to possible embodiments of the present invention;

40 figures 4-11 represent partial sectional views of a sequence of phases of a complete intake-exhaust cycle of an endothermic engine comprising a full dual distribution system (DDI) according to a possible embodiment of the present invention.

45 **[0009]** The elements or parts of elements in common between the embodiments described hereinafter will be indicated at the same numerical references.

DETAILED DESCRIPTION

50 **[0010]** With reference to the aforementioned figures, a total schematic view of an endothermic engine according to the present invention is collectively indicated at 4.

[0011] For the purposes of the present invention, the type, power and/or displacement of the endothermic engine, as well as the type of vehicle, motorcycle, watercraft or aircraft to which it is intended, are not relevant, even though, as described, the present invention is preferably, but not exclusively, for automotive, motorcycling or other disciplines involving the use of an endothermic engine.

[0012] The endothermic engine 4 comprises at least one cylinder 8 which houses and drives, according to a reciprocating rectilinear motion, a piston 12 operatively connected to a drive shaft according to a connecting rod/crank mechanism 16, in a known manner.

[0013] The cylinder 8 is provided with at least one first main intake valve 20 and at least one first main exhaust valve 24, each adapted to close the access to the cylinder 8 and inserted at least partially in a relevant first main manifold 28. Typically, the first main intake and exhaust valves 20, 24 are poppet valves, provided with reciprocating rectilinear motion. The actuation of said poppet valves is usually achieved by camshafts 32, in a known manner.

[0014] According to the present invention, at least one of said first main intake and/or exhaust valves 20,24 is fluidically connected to a first main manifold 28 that forks into an intake channel 36 intercepted by a secondary intake valve 40 and into an exhaust channel 44 intercepted by a secondary exhaust valve 48.

[0015] The intake channel 36 is fluidically connected to an intake system of the engine (not shown) and the exhaust channel 44 is fluidically connected to an exhaust system of the engine (not shown).

[0016] It should be noted that depending on the type of cylinder configuration/architecture of the engine (whether in-line, V, Boxer and the like), the intake channel 36 (or intake channels 36) and the exhaust channel 44 (or exhaust channels 44) may be shared, for example, by each cylinder bank of the engine.

[0017] Generally, an intake system is typically an air duct that draws air from the outside environment and conducts it into the combustion chamber through said intake channel 36 of the first main manifold 28, after filtering the air. The filter may be placed, for example, in a suitable filter box upstream of the first main manifold 28.

[0018] For example, said exhaust system comprises one or more combustion gas collectors that are introduced into an expansion compartment which may, for example, contain one or more treatment devices for combustion gases prior to introducing them into the atmosphere. The combustion gas treatment may also be absent, for example, from vehicles intended for competitions.

[0019] Advantageously, the secondary intake and exhaust valves 40,48 are kinematically connected in synchronism with the respective first main intake and/or exhaust valve 20,24 so as to cyclically allow the additional entry of air into the cylinder 8 through the intake channel 36, connected to the first main exhaust valve 24, at least partially simultaneously with the inlet of air from the first main intake valve 20, and/or to allow the additional exit of combustion gases from the cylinder 8 through the exhaust channel 44, connected to the first main intake valve 20, at least partially simultaneously with the exit of combustion gases through the first main exhaust valve 24.

[0020] The present invention provides, as better described below, the possibility of using a secondary dis-

tribution, comprising the aforementioned intake and exhaust valves 40,48 upstream of the primary distribution comprising the intake and exhaust valves 20,24.

[0021] Such solution may be achieved by a partial dual distribution intake system (DDP-A; figure 1), by a partial dual distribution exhaust system (DDP-S; figure 2) and by a full dual distribution system (DDI, figure 3).

[0022] In particular, according to a first embodiment, in said partial dual distribution intake system (DDP-A; figure 1), the first main intake valve 20 is fluidically connected to a main intake duct 52, while the first main exhaust valve 24 is fluidically connected to a first main manifold 28 that forks into an intake channel 36 intercepted by a secondary intake valve 40 and into an exhaust channel 44, intercepted by a secondary exhaust valve 48.

[0023] Said secondary intake and exhaust valves 40,48 are kinematically connected in synchronism with the first main intake valve 20 so as to cyclically allow the additional entry of air in the cylinder 8 through the intake channel 36, at least partially simultaneously with the entry of air from the first main intake valve 20 through the main intake duct 52, and to allow the exit of combustion gases from the cylinder 8 through the exhaust channel 44.

[0024] In particular, according to a further embodiment, in said partial dual distribution exhaust system (DDP-S; figure 2), the first main exhaust valve 24 is fluidically connected to a second main manifold 56, while the first main exhaust valve 20 is fluidically connected to a first main manifold 28 that forks into an intake channel 36 intercepted by a secondary intake valve 40 and into an exhaust channel 44 intercepted by a secondary exhaust valve 48.

[0025] Said secondary intake and exhaust valves 40,48 are kinematically connected in synchronism with the first main exhaust valve 24 so as to cyclically allow the additional exit of combustion gases from the cylinder 8 through the exhaust channel 44, at least partially simultaneously with the exit of combustion gases from the first main exhaust valve 24 through the second main manifold 56, and to allow the entry of air in the cylinder 8 through the intake channel 36.

[0026] Preferably, the engine 4, as shown, comprises a full dual distribution system (DDI; figure 3) which provides for the use of first main manifolds 28 which engage at both the first main intake valve 20 and the first main exhaust valve 24, each of which forks into an intake channel 36 and into an exhaust channel 44. Therefore, each first main manifold 28 is capable by means of the respective intake and exhaust channels 36,44 to provide an additional inlet air flow and outlet flow for combustion gas with respect to the normal allowed flow of the intake and exhaust valves 20,24.

[0027] The foregoing applies both to engines 4 having two valves per cylinder, i.e. an intake valve and an exhaust valve, and to engines having three, four or even more valves per cylinder. Therefore, for the purposes of the scope of protection of this patent, embodiments having at least two valves per cylinder are protected.

[0028] The figures provided in the patent always show an intake valve and an exhaust valve for convenience and greater intelligibility of the figures.

[0029] A preferred embodiment provides for the application of the present invention to an engine having four valves per cylinder.

[0030] For example (figure 3b), the cylinder 8 is provided with at least one second main intake valve 120 and at least one second main exhaust valve 124, wherein at least one of said second main intake and/or exhaust valves 120, 124 is connected fluidically to a second main manifold 128 which is forked into a second intake channel 136 intercepted by a secondary intake valve 40 and into a second exhaust channel 144 intercepted by a secondary exhaust valve 48.

[0031] The second intake channel 136 is fluidically connected to the intake system of the engine, along with the intake channel 36.

[0032] The second exhaust channel 144 is fluidically connected to the exhaust system of the engine, along with the exhaust channel 44.

[0033] Advantageously, said secondary intake and exhaust valves 40,48 are kinematically connected in synchronism with the respective second main intake 120 and/or exhaust 124 valve so as to cyclically allow the additional entry of air into the cylinder through the second intake channel 136, connected to the second main exhaust valve 124, at least partially simultaneously with the entry of air from the second main intake valve 120, and/or to allow the additional exit of combustion gases from the cylinder through the second exhaust channel 144, connected to the second main intake valve 120, at least partially simultaneously with the exit of combustion gases through the second main exhaust valve 124.

[0034] As seen, the main valves are preferably poppet valves.

[0035] The secondary intake and exhaust valves 40, 48 are preferably rotary valves.

[0036] For example, said rotary valves comprise a cylindrical or spherical body 60 defining an inner channel 64 rotating integrally with the body. Said inner channel 64 has a lumen 68 of a dimension similar to the lumen 72 of the intake channel 36,136 or the exhaust channel 44,144 within which the valve is inserted; in this way, during the rotation of the body 60, the inner channel 64 cyclically passes from an angular orientation where it is at least partially aligned with the related lumen 72 of the intake channel 36,136 or exhaust channel 44,144 at an angular orientation wherein it is totally misaligned with respect to the latter.

[0037] It is evident that the alignment, even partial, is configured as the opening of the rotary valve and allows the incoming air or outgoing exhaust gas to pass through, while the full misalignment is configured as the closing of the rotary valve.

[0038] It should be noted that the outer diameter and the passage diameter of the rotary valves are suitably calibrated and calculated inasmuch as the closing or

opening of the duct depends on their relative ratio.

[0039] The system lends itself to being easily adopted in multi-cylinder engines simply by using a cylinder where the through-holes are properly rotated according to the respective crank angle.

[0040] The rotary valves are not subject to strong pressures because the totality of the sealing work remains dependent on the main valves. Therefore, no particularly sophisticated seals are required.

[0041] According to a possible embodiment, said rotary valves are controlled by a main distribution apparatus of the engine comprising at least one camshaft 32. Preferably, the same camshaft or camshafts 32 control both the main valves 20, 120, 24, 124 and the secondary valves 40, 48.

[0042] For example, the secondary intake and exhaust valves 40, 48 are rotary valves actuated at the same rotational speed of at least one camshaft 32 which controls the actuation of the main valves. In the case of symmetrical rotary valves, the rotation speed of the same could also be reduced to $\frac{1}{2}$ of the camshaft's rotation speed.

[0043] Advantageously, the first and second main manifolds 28, 128 of each main valve 20, 120, 24, 124 are separated so that they do not provide any direct fluidic connection. This avoids the hold time of gas in a shared volume or buffer between the same ducts.

[0044] It should be noted that in the case of an engine with 4 valves per cylinder (typically two intake valves and two exhaust valves), the two main exhaust valves 24 may have a first common duct intercepted by the same secondary exhaust valves 48; only subsequently to such first common duct will the same duct fork into two branches that will each merge into a single valve.

[0045] Preferably, the secondary valves are positioned within the respective manifolds 28 so as to be away from the corresponding intake 20,120 and/or exhaust 24,124 valves at the minimum possible distance, compatible with the construction and cooling requirements.

[0046] Preferably, the secondary valves 40, 48 of a same first main manifold 28 are mutually phased so as to have a cross phase, i.e. at least a partial opening at the same time, so as to facilitate the emptying of the gases inside the same duct.

[0047] In effect, during the exhaust phase, a combustion flow portion may remain trapped in the buffer zone. In order to prevent this air mass from being re-aspirated by the engine, an adequate cross phase is necessary so that the downstream depression of the secondary exhaust valve 48 may empty the buffer.

[0048] In the case of multi-cylinder engines with intake and exhaust ducts shared among the various cylinders, the arrangement of exhaust ducts and phasing of the valves will be suitable in order to avoid that the passive cross phase (i.e. with the main valves closed) coincides with an active exhaust phase (i.e. with the main valves open) of another cylinder having a shared duct.

[0049] Finally, in a known manner, the engine 4 comprises fuel injector devices (not shown) arranged down-

stream of said secondary intake valves 40.

[0050] In effect, since a certain amount of air could pass from the secondary intake valve 40 to the exhaust without passing through the engine 4, in order to assure that the buffer ("overflow") is empty, the fuel should only be injected downstream of the secondary intake valve 40 and only when the exhaust valve is completely (or nearly) closed.

[0051] Preferably, said injector devices are arranged so as to inject the fuel directly into the cylinder; in this way the problem is completely solved.

[0052] The operation of an endothermic engine according to the present invention will now be described.

[0053] It should be noted that the phasing angles, the lifts and the opening/closing angles of the secondary valves are purely indicative and, in this context, serve solely to better define the operation of the present invention.

[0054] Reference will be made to figures 4-11 relating to a sequence of phases of a complete intake-exhaust cycle of an endothermic engine comprising a full dual distribution system (DDI) according to a possible embodiment of the present invention. It is evident that the following also applies to the embodiments of endothermic engines comprising partial dual distribution intake (DDP-A) and/or exhaust (DDP-S) system according to the present invention.

[0055] In particular, figure 4 illustrates the beginning of the intake phase, coinciding with the end of the exhaust phase. The main valves are in the maximum lift state, the secondary rotary intake valves are in the opening state (about 5 degrees), and the secondary rotary exhaust valves are in the opening state (about 25 degrees).

[0056] Figure 5 continues with the intake phase and reaches the end of the exhaust phase. The main valves are in maximum lift state, the secondary rotary intake valves are in opening state (about 25 degrees), while the secondary rotary exhaust valves are in closing state. It should be noted that, in the passage from the exhaust phase to the intake phase, the main valves have remained motionless in the open position, thus maximizing the passage area of the fluids.

[0057] Figure 6 again illustrates the intake phase. In particular, the main valves are in maximum lift state and beginning of closure, the secondary rotary intake valves are in the maximum opening state (in other words, the respective inner channel is aligned parallel to the related intake duct in order to allow the maximum lumen of the air passage), while the secondary rotary exhaust valves are closed. As shown, for the purpose of the closing state, it is sufficient that the inner channel of a valve is not, even partially, aligned with the respective channel wherein the rotary valve is inserted.

[0058] Figure 7 shows the end of the intake phase and the beginning of the compression phase. In particular, the main valves are closed, the secondary rotary intake valves are in the closing phase, open about 25 degrees; however, such position is irrelevant as the main valves

are closed whereby the duct is fluidically separated from the cylinder. The secondary rotary exhaust valves are closed: also in this case their position is irrelevant. Figure 8 illustrates the end of the compression phase. The main valves are closed, the secondary rotary intake valves and the secondary rotary exhaust valves still have an irrelevant position.

[0059] Figure 9 illustrates the end of the expansion phase coinciding with the beginning of the exhaust phase. The main valves are in the opening state, while the secondary rotary intake valves are in the closing state. The secondary rotary exhaust valves are instead in the opening state.

[0060] Figure 10 shows the exhaust phase. In particular the main valves are in the maximum lift state, the secondary rotary intake valves are closed, while the secondary rotary exhaust valves are in the maximum opening state.

[0061] Finally, figure 11 shows the end of the exhaust phase. The main valves are in the maximum lift state, the secondary rotary intake valves are in the opening state, while the secondary rotary exhaust valves are in the closing state (approximately 25 degrees).

[0062] Obviously, the foregoing description refers to the more complex full dual distribution system (DDI), but it may obviously also be extended, with the due omissions, to simpler partial dual distribution intake (DDP-A) and exhaust (DDP-S) solutions.

[0063] As may be appreciated from the description, the endothermic engine according to the invention overcomes the disadvantages of the prior art.

[0064] In particular, the endothermic engine allows the improvement of the volumetric and pumping efficiency with respect to the prior art solutions.

[0065] In the case of a full dual distribution system (DDI), the gas transfer area, both in intake and exhaust, virtually doubles with respect to a standard solution. Even considering the complexity of the system and some loss due to the possible heat exchange with the warmer parts, a conservative estimate could suggest a 10%-15% volumetric increase, as well as a better pumping efficiency in the case of turbocharged engines.

[0066] In the case of a partial dual distribution intake system (DDP-A), the intake passage area virtually doubles, while the exhaust area remains unchanged, the opposite occurs in the case of the partial dual distribution exhaust system (DDP-S). In the first case (DDP-A), only volumetric efficiency is increased: this improvement is certainly notable and useful in case of use on aspirated engines, i.e. not supercharged.

[0067] In any case, the partial dual distribution intake system (DDP-A), with respect to the full dual distribution system (DDI), has greater constructive simplicity, is lighter, and is suitable, as is seen in aspirated engines as well as in those cases where the exhaust outlet of the engine is constrained by constructive or regulatory requirements.

[0068] In the second case of a partial dual distribution

exhaust system (DDP-S), only pumping efficiency is increased: such improvement is notable and useful in turbocharged engines.

[0069] In any case, the partial dual distribution exhaust system (DDP-S), with respect to the full dual distribution system (DDI), has greater constructive simplicity, is lighter, and is suitable, as seen in turbocharged engines.

[0070] A person skilled in the art, in the object of satisfying contingent and specific requirements, may make numerous modifications and variations to the engines described above, all of which are within the scope of the invention as defined by the following claims.

Claims

1. Endothermic engine (4) comprising

- at least one cylinder (8) that receives and guides, according to a reciprocating rectilinear motion, a piston (12) operatively connected to a drive shaft according to a connecting rod/crank mechanism (16), the cylinder (8) being provided with at least one first main intake valve (20) fluidically connected to a first main manifold (28), and at least one first main exhaust valve (24) fluidically connected to a second main manifold (56), wherein

at least one of the first and second main manifold (28, 56) forks into an intake channel (36) and into an exhaust channel (44),

- wherein the intake channel (36) is fluidically connected to an intake system of the engine (4), and the exhaust channel (44) is fluidically connected to an exhaust system of the engine (4), **characterized in that**

the intake channel (36) is intercepted by a secondary intake valve (40) and the exhaust channel (44) is intercepted by a secondary exhaust valve (48),

- said secondary intake and exhaust valves (40,48) being kinematically connected in synchronism with the respective first main intake and/or exhaust valve (20,24) so as to cyclically allow:

- the additional entry of air in the cylinder (8) through the intake channel (36), connected to said first main exhaust valve (24), at least partially simultaneously with the entry of air from said first main intake valve (20), and/or to allow

- the additional exit of combustion gases from the cylinder (8) through the exhaust channel (44), connected to said first main intake valve (20), at least partially simultaneously with the exit of combustion gases through said first main exhaust valve (24).

2. Endothermic engine (4) according to claim 1, where-

in the first main intake valve (20) is fluidically connected to a main intake duct (52), wherein the first main exhaust valve (24) is fluidically connected to a first main manifold (28) that forks into an intake channel (36) intercepted by a secondary intake valve (40) and into an exhaust channel (44) intercepted by a secondary exhaust valve (48),

- said secondary intake and exhaust valves (40,48) being kinematically connected in synchronism with the first main intake valve (20) so as to cyclically allow the additional entry of air in the cylinder (8) through the intake channel (36), at least partially simultaneously with the entry of air from the first main intake valve (20) through the main intake duct (52), and to allow the exit of combustion gases from the cylinder (8) through the exhaust channel (44).

3. Endothermic engine (4) according to claim 1 or 2, wherein the first main exhaust valve (24) is fluidically connected to a second main manifold (56), wherein the first main intake valve (20) is fluidically connected to a first main manifold (28) that forks into an intake channel (36) intercepted by a secondary intake valve (40) and into an exhaust channel (44) intercepted by a secondary exhaust valve (48),

- said secondary intake and exhaust valves (40,48) being kinematically connected in synchronism with the first main exhaust valve (24) so as to cyclically allow the additional exit of combustion gases from the cylinder (8) through the exhaust channel (44), at least partially simultaneously with the exit of combustion gases from the first main exhaust valve (24) through the second main manifold (56), and to allow the entry of air in the cylinder (8) through the intake channel (36).

4. Endothermic engine (4) according to any of the preceding claims, wherein the cylinder (8) is provided with at least one second main intake valve (120) and at least one second main exhaust valve (124),

characterized in that

- at least one of said second main intake and/or exhaust valves (120,124) is fluidically connected to a second main manifold (128) that forks into a second intake channel (136) intercepted by a secondary intake valve (40) and into a second exhaust channel (144) intercepted by a secondary exhaust valve (148),

- wherein the second intake channel (136) is fluidically connected to an intake system of the engine (4) and the exhaust channel is fluidically connected to an exhaust system of the engine (4),

- said secondary intake and exhaust valves (40,48) being kinematically connected in synchronism with the respective second main intake (120) and/or exhaust (124) valve so as to cyclically allow the additional entry of air in the cylinder (8) through the second intake channel (136), connected to the second main exhaust valve (124), at least partially simultaneously with the entry of air from the second main intake valve (120), and/or to allow the additional exit of combustion gases from the cylinder (8) through the second exhaust channel (144), connected to the second main intake valve (120), at least partially simultaneously with the exit of combustion gases through the second main exhaust valve (124).
- 5
- 10
- 15
- 20
- 25
- 30
- 35
- 40
- 45
- 50
- 55
5. Endothermic engine (4) according to any of the preceding claims, wherein the main valves (20,120,24,124) are poppet valves, provided with a reciprocating rectilinear motion, and wherein the secondary valves (40, 48) are rotary valves.
 6. Endothermic engine (4) according to claim 5, wherein said rotary valves (40,48) are controlled by a main distribution apparatus of the engine (4) comprising at least one camshaft (32).
 7. Endothermic engine (4) according to claim 5 or 6, wherein said rotary valves (40,48) comprise a cylindrical or spherical body (60) that delimits an internal channel (64) that rotates integrally with the body (60), said internal channel (64) having a lumen (68) of similar dimension to the lumen (72) of the intake (36, 136) or exhaust (44,144) channel inside of which the valve is inserted, so that, during rotation of the body (60), the internal channel (64) cyclically passes from an angular orientation wherein it is at least partially aligned with the respective lumen (72) of the intake (36,136) or exhaust (44,144) channel to an angular orientation wherein it is totally misaligned with respect to the latter.
 8. Endothermic engine (4) according to any of the preceding claims, in which all the main (20,120,24,124) and secondary (40,48) valves are mechanically connected to the same main distribution apparatus for the respective actuation.
 9. Endothermic engine (4) according to any of the preceding claims, wherein which the secondary valves (40, 48) are rotary valves driven at the same speed of rotation, or at 1/2 of the speed of rotation of at least one camshaft (32) that controls the actuation of the main valves (20,120,24,124).
 10. Endothermic engine (4) according to any of the preceding claims, wherein the first main manifolds (28) of each main valve (20,120,24,124) are separated

from each other so as not to provide any direct fluidic connection.

11. Endothermic engine (4) according to any of the preceding claims, wherein which the secondary valves (40, 48) of a same first main manifold (28) are mutually phased in a suitable manner, so as to facilitate the emptying of the gases inside the first main manifold (28) itself.
12. Endothermic engine (4) according to any of the preceding claims, wherein the secondary valves (40,48) are phased so as to provide an intersection phase, i.e., of at least partial simultaneous opening.
13. Endothermic engine (4) according to any of the preceding claims, wherein the engine (4) comprises fuel injection devices disposed so as to inject the fuel directly into the cylinder (8).

Patentansprüche

1. Ein endothermer Motor (4), der Folgendes umfasst:
 - mindestens einen Zylinder (8), der, gemäß einer hin- und hergehenden geradlinigen Bewegung, einen Kolben (12) aufnimmt und führt, der gemäß eines Verbindungsstangen- / Kurbel-Mechanismus' (16) funktionsfähig mit einer Antriebswelle verbunden ist, wobei der Zylinder (8) mit mindestens einem ersten Haupteinlassventil (20) versehen ist, das mit einem ersten Hauptverteiler (28) fluidisch verbunden ist, und mindestens einem ersten Hauptausslassventil (24), das mit einem zweiten Hauptverteiler (56) fluidisch verbunden ist, wobei
 - mindestens einer der Hauptverteiler eins und zwei (28, 56) in einen Einlasskanal (36) und in einen Auslasskanal (44) abzweigt,
 - wobei der Einlasskanal (36) mit einem Einlasssystem des Motors (4) fluidisch verbunden ist, und der Auslasskanal (44) mit einem Auslasssystem des Motors (4) fluidisch verbunden ist, **dadurch gekennzeichnet, dass** der Einlasskanal (36) durch ein sekundäres Einlassventil (40) unterbrochen wird (*intercepted*) und der Auslasskanal (44) durch ein sekundäres Auslassventil (48) unterbrochen wird,
 - wobei die genannten sekundären Ventile für Einlass- und Auslass (40, 48) kinematisch synchron mit dem jeweiligen ersten Haupteinlass- und/oder Auslassventil (20, 24) verbunden sind, um zyklisch Folgendes zu ermöglichen:
 - den zusätzlichen Lufteintritt in den Zylinder (8) durch den Einlasskanal (36), der mit dem

- genannten ersten Hauptauslassventil (24) verbunden ist, zumindest teilweise gleichzeitig mit dem Lufteintritt aus dem genannten ersten Haupteinlassventil (20), und/oder um Folgendes zu ermöglichen:
- den zusätzlichen Auslass von Verbrennungsgasen aus dem Zylinder (8) durch den Auslasskanal (44), der mit dem genannten ersten Haupteinlassventil (20) verbunden ist, zumindest teilweise gleichzeitig mit dem Auslass von Verbrennungsgasen durch das genannte erste Hauptauslassventil (24).
2. Der endotherme Motor (4) nach Anspruch 1, wobei das erste Haupteinlassventil (20) mit einem Haupteinlasskanal (52) fluidisch verbunden ist, wobei das erste Hauptauslassventil (24) mit einem ersten Hauptverteiler (28) fluidisch verbunden ist, der in einen Einlasskanal (36) zweigt, der von einem sekundären Einlassventil (40) unterbrochen wird, und in einen Auslasskanal (44), der von einem sekundären Auslassventil (48) unterbrochen wird,
- wobei die genannten Ventile für Einlass- und Auslass (40, 48) kinematisch synchron mit dem ersten Haupteinlassventil (20) verbunden sind, um zyklisch den zusätzlichen Eintritt von Luft in den Zylinder (8) durch den Einlasskanal (36) zu ermöglichen, zumindest teilweise gleichzeitig mit dem Eintritt von Luft aus dem ersten Haupteinlassventil (20) durch den Haupteinlasskanal (52), und um den Austritt von Verbrennungsgasen aus dem Zylinder (8) durch den Auslasskanal (44) zu ermöglichen.
3. Der endotherme Motor (4) nach Anspruch 1 oder 2, wobei das erste Hauptauslassventil (24) mit einem zweiten Hauptverteiler (56) fluidisch verbunden ist, wobei das erste Haupteinlassventil (20) mit einem ersten Hauptverteiler (28) fluidisch verbunden ist, der in einen Einlasskanal (36) abzweigt, der von einem sekundären Einlassventil (40) unterbrochen wird, und in einen Auslasskanal (44) abzweigt, der von einem sekundären Auslassventil (48) unterbrochen wird,
- wobei die genannten sekundären Ventile für Einlass- und Auslass (40, 48) kinematisch synchron mit dem ersten Hauptauslassventil (24) verbunden sind, um zyklisch den zusätzlichen Auslass von Verbrennungsgasen aus dem Zylinder (8) durch den Auslasskanal (44), zumindest teilweise gleichzeitig mit dem Austritt von Verbrennungsgasen aus dem ersten Hauptauslassventil (24) durch den zweiten Hauptverteiler (56), zu ermöglichen und den Eintritt von Luft in
- den Zylinder (8) durch den Einlasskanal (36) zu ermöglichen.
4. Der endotherme Motor (4) nach irgendeinem der vorstehenden Ansprüche, wobei der Zylinder (8) mit mindestens einem zweiten Haupteinlassventil (120) und mindestens einem zweiten Hauptauslassventil (124) versehen ist, **dadurch gekennzeichnet, dass**
- mindestens eines der genannten zweiten Ventile für Einlass- und Auslass (120, 124) fluidisch mit einem zweiten Hauptverteiler (128) verbunden ist, der in einen zweiten Einlasskanal (136) abzweigt, der von einem sekundären Einlassventil (40) unterbrochen wird, und in einen zweiten Auslasskanal (144) abzweigt, der von einem sekundären Auslassventil (148) unterbrochen wird,
 - wobei der zweite Einlasskanal (136) mit einem Einlasssystem des Motors (4) fluidisch verbunden ist und der Auslasskanal mit einem Auslasssystem des Motors (4) fluidisch verbunden ist,
 - wobei die genannten sekundären Ventile für Einlass- und Auslass (40, 48) kinematisch synchron mit dem jeweiligen zweiten Haupteinlassventil (120) und/oder Auslassventil (124) verbunden sind, um zyklisch den zusätzlichen Eintritt von Luft in den Zylinder (8) durch den zweiten Einlasskanal (136) zu ermöglichen, der mit dem zweiten Hauptauslassventil (124) verbunden ist, zumindest teilweise gleichzeitig mit dem Lufteintritt aus dem zweiten Haupteinlassventil (120), und/oder um den zusätzlichen Austritt von Verbrennungsgasen aus dem Zylinder (8) durch den zweiten Auslasskanal (144) zu ermöglichen, der mit dem zweiten Haupteinlassventil (120) verbunden ist, zumindest teilweise gleichzeitig mit dem Auslass von Verbrennungsgasen durch das zweite Hauptauslassventil (124).
5. Der endotherme Motor (4) nach irgendeinem der vorstehenden Ansprüche, wobei die Hauptventile (20, 120, 24, 124) Tellerventile (*poppet valves*) sind, die mit einer hin- und hergehenden geradlinigen Bewegung versehen sind, und wobei die Sekundärventile (40, 48) Drehventile sind.
6. Der endotherme Motor (4) nach Anspruch 5, wobei die genannten Drehventile (40, 48) durch eine Hauptverteilungsvorrichtung des Motors (4) gesteuert werden, die mindestens eine Nockenwelle (32) umfasst.
7. Der endotherme Motor (4) nach Anspruch 5 oder 6, wobei die genannten Drehventile (40, 48) einen zylindrischen oder kugelförmigen Körper (60) umfas-

- sen, der einen internen Kanal (64) begrenzt, der sich integral mit dem Körper (60) dreht, wobei der genannte interne Kanal (64) ein Lumen (68) mit einer ähnlichen Abmessung wie das Lumen (72) des Einlass- (36, 136) oder Auslasskanals (44, 144) aufweist, in den das Ventil eingesetzt ist, sodass während der Drehung des Körpers (60) der interne Kanal (64) zyklisch von einer Winkelorientierung, bei der er zumindest teilweise mit dem jeweiligen Lumen (72) des Einlass- (36, 136) oder Auslasskanals (44, 144) ausgerichtet ist, zu einer Winkelorientierung übergeht, bei der er in Bezug auf Letztere völlig fehlgerichtet ist.
8. Der endotherme Motor (4) nach irgendeinem der vorstehenden Ansprüche, bei dem alle Hauptventile (20, 120, 24, 124) und sekundären Ventile (40, 48) für die jeweilige Betätigung mechanisch mit derselben Hauptverteilungsvorrichtung verbunden sind.
9. Der endotherme Motor (4) nach irgendeinem der vorstehenden Ansprüche, wobei die sekundären Ventile (40, 48) Drehventile sind, die mit der gleichen Drehgeschwindigkeit oder mit der $\frac{1}{2}$ Drehgeschwindigkeit von mindestens einer Nockenwelle (32) angetrieben werden, die die Betätigung der Hauptventile (20, 120, 24, 124) steuert.
10. Der endotherme Motor (4) nach irgendeinem der vorstehenden Ansprüche, wobei die ersten Hauptverteiler (28) jedes Hauptventils (20, 120, 24, 124) voneinander getrennt sind, um keine direkte fluidische Verbindung herzustellen.
11. Der endotherme Motor (4) nach irgendeinem der vorstehenden Ansprüche, wobei die sekundären Ventile (40, 48) eines selben ersten Hauptverteilers (28) zueinander auf geeignete Weise phasenverschoben sind, um die Entleerung der Gase innerhalb des ersten Hauptverteilers (28) selbst zu erleichtern.
12. Der endotherme Motor (4) nach irgendeinem der vorstehenden Ansprüche, wobei die sekundären Ventile (40, 48) so phasenversetzt sind, dass sie eine sich überschneidende Phase (*intersection phase*), d.h. eine zumindest teilweise gleichzeitige Öffnung, bilden.
13. Der endotherme Motor (4) nach irgendeinem der vorstehenden Ansprüche, wobei der Motor (4) Kraftstoffeinspritzvorrichtungen umfasst, die so angeordnet sind, dass sie den Kraftstoff direkt in den Zylinder (8) einspritzen.

Revendications

1. Moteur endothermique (4) comprenant

- au moins un cylindre (8) qui reçoit et guide, selon un mouvement rectiligne alternatif, un piston (12) relié de manière fonctionnelle à un arbre d'entraînement selon un mécanisme bielle-manivelle (16), le cylindre (8) étant pourvu d'au moins une première soupape d'admission principale (20) reliée de manière fluidique à un premier collecteur principal (28), et au moins une première soupape d'échappement principale (24) reliée de manière fluidique à un second collecteur principal (56), dans lequel au moins l'un du premier et du second collecteur principal (28, 56) se divise en un canal d'admission (36) et en un canal d'échappement (44), - dans lequel le canal d'admission (36) est relié de manière fluidique à un système d'admission du moteur (4), et le canal d'échappement (44) est relié de manière fluidique à un système d'échappement du moteur (4),

caractérisé en ce que

le canal d'admission (36) est intercepté par une soupape d'admission secondaire (40) et le canal d'échappement (44) est intercepté par une soupape d'échappement secondaire (48),

- lesdites soupapes d'admission et d'échappement secondaires (40, 48) étant reliées de manière cinématique en synchronisation avec la première soupape d'admission et/ou d'échappement principale (20, 24) respective de façon à permettre de manière cyclique :

- l'entrée additionnelle d'air dans le cylindre (8) à travers le canal d'admission (36), relié à ladite première soupape d'échappement principale (24), au moins en partie simultanément avec l'entrée d'air depuis ladite première soupape d'admission principale (20), et/ou à permettre

- la sortie additionnelle de gaz de combustion depuis le cylindre (8) à travers le canal d'échappement (44), relié à ladite première soupape d'admission principale (20), au moins en partie simultanément avec la sortie de gaz de combustion à travers ladite première soupape d'échappement principale (24).

2. Moteur endothermique (4) selon la revendication 1, dans lequel la première soupape d'admission principale (20) est reliée de manière fluidique à un conduit d'admission principal (52), dans lequel la première soupape d'échappement principale (24) est reliée de manière fluidique à un premier collecteur principal (28) qui se divise en un canal d'admission (36) intercepté par une soupape d'admission secondaire (40) et en un canal d'échappement (44) intercepté par une soupape d'échappement secondaire

(48),

- lesdites soupapes d'admission et d'échappement secondaires (40, 48) étant reliées de manière cinématique en synchronisation avec la première soupape d'admission principale (20) de façon à permettre de manière cyclique l'entrée additionnelle d'air dans le cylindre (8) à travers le canal d'admission (36), au moins en partie simultanément avec l'entrée d'air depuis la première soupape d'admission principale (20) à travers le conduit d'admission principal (52), et à permettre la sortie de gaz de combustion depuis le cylindre (8) à travers le canal d'échappement (44).

3. Moteur endothermique (4) selon la revendication 1 ou 2, dans lequel la première soupape d'échappement principale (24) est reliée de manière fluïdique à un second collecteur principal (56), dans lequel la première soupape d'admission principale (20) est reliée de manière fluïdique à un premier collecteur principal (28) qui se divise en un canal d'admission (36) intercepté par une soupape d'admission secondaire (40) et en un canal d'échappement (44) intercepté par une soupape d'échappement secondaire (48),

- lesdites soupapes d'admission et d'échappement secondaires (40, 48) étant reliées de manière cinématique en synchronisation avec la première soupape d'échappement principale (24) de façon à permettre de manière cyclique la sortie additionnelle de gaz de combustion depuis le cylindre (8) à travers le canal d'échappement (44), au moins en partie simultanément avec la sortie de gaz de combustion depuis la première soupape d'échappement principale (24) à travers le second collecteur principal (56), et à permettre l'entrée d'air dans le cylindre (8) à travers le canal d'admission (36).

4. Moteur endothermique (4) selon l'une quelconque des revendications précédentes, dans lequel le cylindre (8) est pourvu d'au moins une seconde soupape d'admission principale (120) et d'au moins une seconde soupape d'échappement principale (124), **caractérisé en ce que**

- au moins l'une desdites secondes soupapes d'admission et/ou d'échappement principales (120, 124) est reliée de manière fluïdique à un second collecteur principal (128) qui se divise en un second canal d'admission (136) intercepté par une soupape d'admission secondaire (40) et en un second canal d'échappement (144) intercepté par une soupape d'échappement secondaire (148),
- dans lequel le second canal d'admission (136)

est relié de manière fluïdique à un système d'admission du moteur (4) et le canal d'échappement est relié de manière fluïdique à un système d'échappement du moteur (4),

- lesdites soupapes d'admission et d'échappement secondaires (40, 48) étant reliées de manière cinématique en synchronisation avec la seconde soupape d'admission principale (120) et/ou d'échappement principale (124) respective de façon à permettre de manière cyclique l'entrée additionnelle d'air dans le cylindre (8) à travers le second canal d'admission (136), relié à la seconde soupape d'échappement principale (124), au moins en partie simultanément avec l'entrée d'air depuis la seconde soupape d'admission principale (120), et/ou à permettre la sortie additionnelle de gaz de combustion depuis le cylindre (8) à travers le second canal d'échappement (144), relié à la seconde soupape d'admission principale (120), au moins en partie simultanément avec la sortie de gaz de combustion à travers la seconde soupape d'échappement principale (124).

5. Moteur endothermique (4) selon l'une quelconque des revendications précédentes, dans lequel les soupapes principales (20, 120, 24, 124) sont des soupapes champignons, pourvues d'un mouvement rectiligne alternatif, et dans lequel les soupapes secondaires (40, 48) sont des soupapes rotatives.
6. Moteur endothermique (4) selon la revendication 5, dans lequel lesdites soupapes rotatives (40, 48) sont commandées par un appareil de distribution principal du moteur (4) comprenant au moins un arbre à cames (32).
7. Moteur endothermique (4) selon la revendication 5 ou 6, dans lequel lesdites soupapes rotatives (40, 48) comprennent un corps cylindrique ou sphérique (60) qui délimite un canal interne (64) qui tourne solidairement avec le corps (60), ledit canal interne (64) ayant une lumière (68) de dimension similaire à la lumière (72) du canal d'admission (36, 136) ou d'échappement (44, 144) à l'intérieur duquel la soupape est insérée, de sorte que, durant la rotation du corps (60), le canal interne (64) passe de manière cyclique d'une orientation angulaire dans laquelle il est au moins en partie aligné avec la lumière respective (72) du canal d'admission (36, 136) ou d'échappement (44, 144) à une orientation angulaire dans laquelle il est totalement désaligné par rapport à celle-ci.
8. Moteur endothermique (4) selon l'une quelconque des revendications précédentes, dans lequel toutes les soupapes principales (20, 120, 24, 124) et secondaires (40, 48) sont reliées mécaniquement au

même appareil de distribution principal pour l'actionnement respectif.

9. Moteur endothermique (4) selon l'une quelconque des revendications précédentes, dans lequel les soupapes secondaires (40, 48) sont des soupapes rotatives entraînées à la même vitesse de rotation, ou à la moitié de la vitesse de rotation d'au moins un arbre à cames (32) qui commande l'actionnement des soupapes principales (20, 120, 24, 124). 5 10
10. Moteur endothermique (4) selon l'une quelconque des revendications précédentes, dans lequel les premiers collecteurs principaux (28) de chaque soupape principale (20, 120, 24, 124) sont séparés l'un de l'autre de façon à ne fournir aucune liaison fluide directe. 15
11. Moteur endothermique (4) selon l'une quelconque des revendications précédentes, dans lequel les soupapes secondaires (40, 48) d'un même premier collecteur principal (28) sont mutuellement mises en phase de manière appropriée, de façon à faciliter l'évacuation des gaz à l'intérieur du premier collecteur principal (28) lui-même. 20 25
12. Moteur endothermique (4) selon l'une quelconque des revendications précédentes, dans lequel les soupapes secondaires (40, 48) sont mises en phase de façon à fournir une phase d'intersection, c'est-à-dire d'au moins une ouverture simultanée partielle. 30
13. Moteur endothermique (4) selon l'une quelconque des revendications précédentes, dans lequel le moteur (4) comprend des dispositifs d'injection de carburant disposés de façon à injecter le carburant directement dans le cylindre (8). 35

40

45

50

55

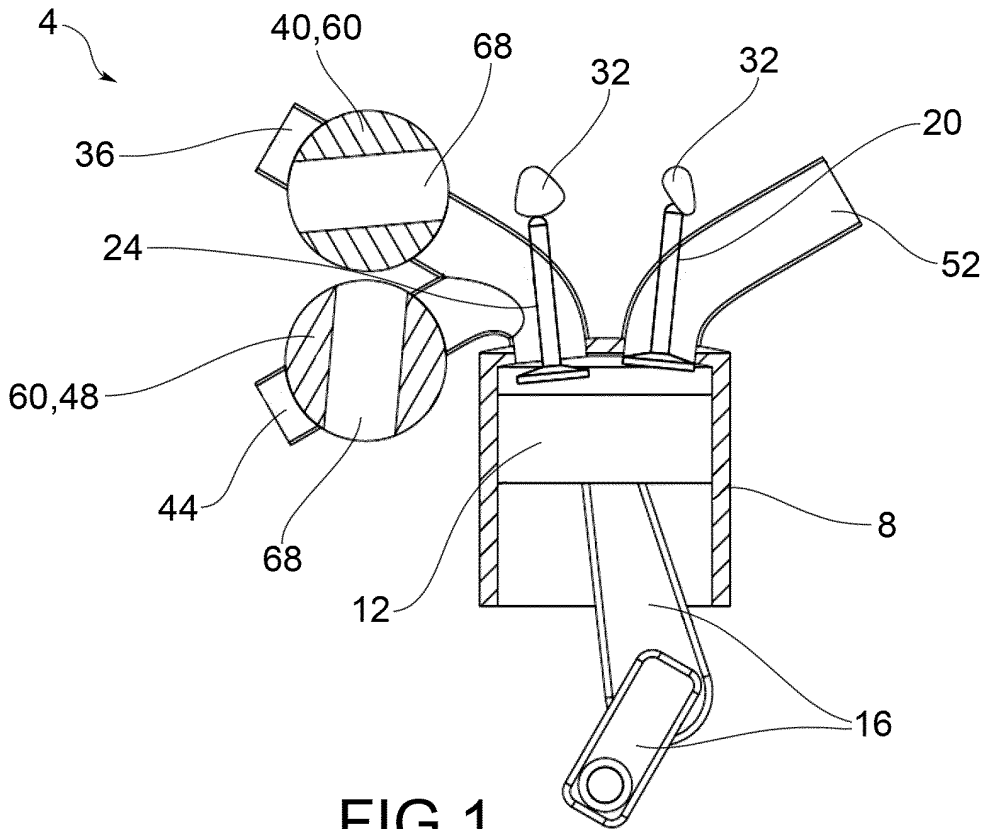

FIG.1

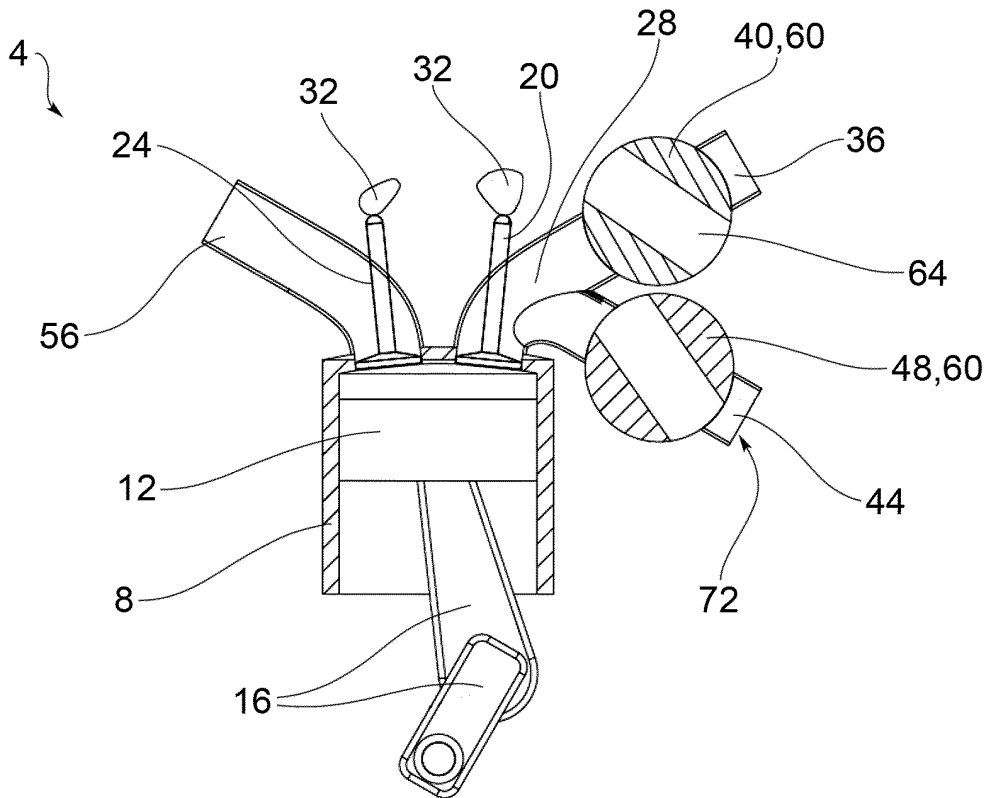

FIG.2

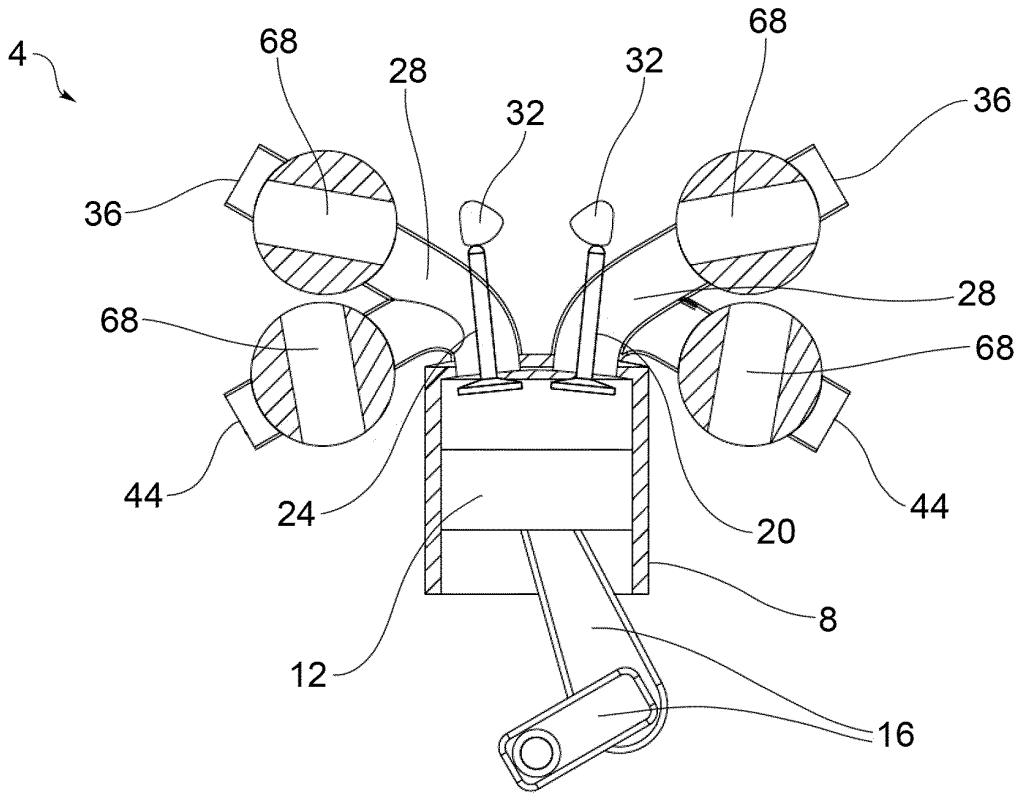

FIG.3a

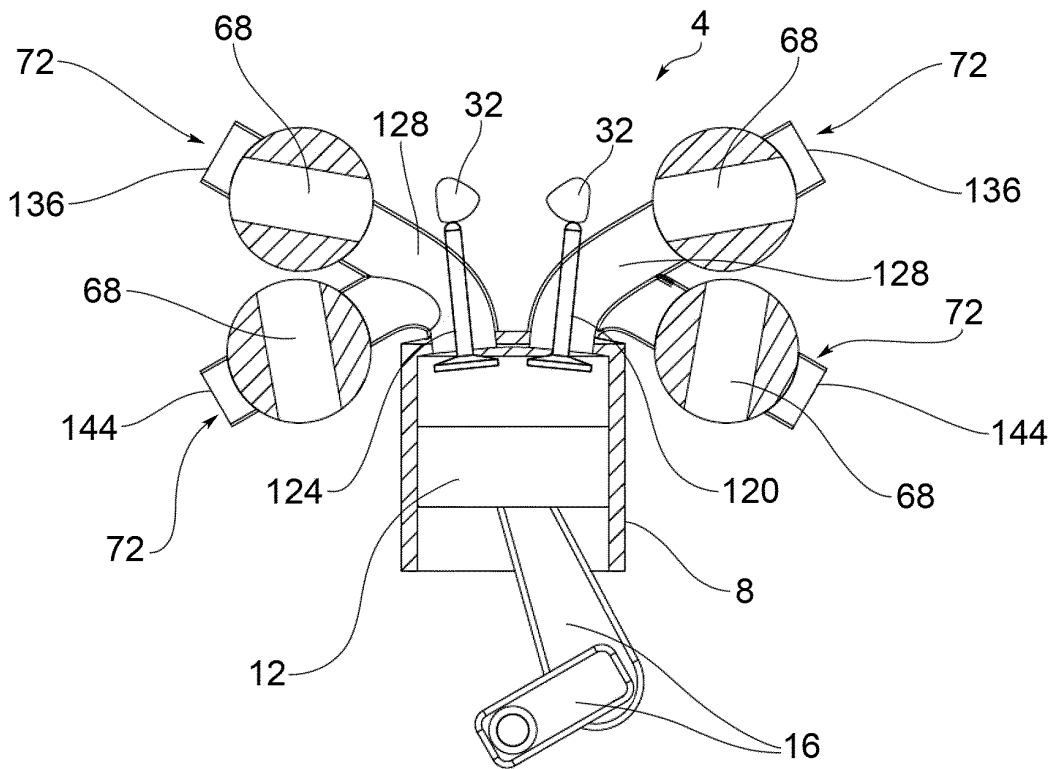

FIG.3b

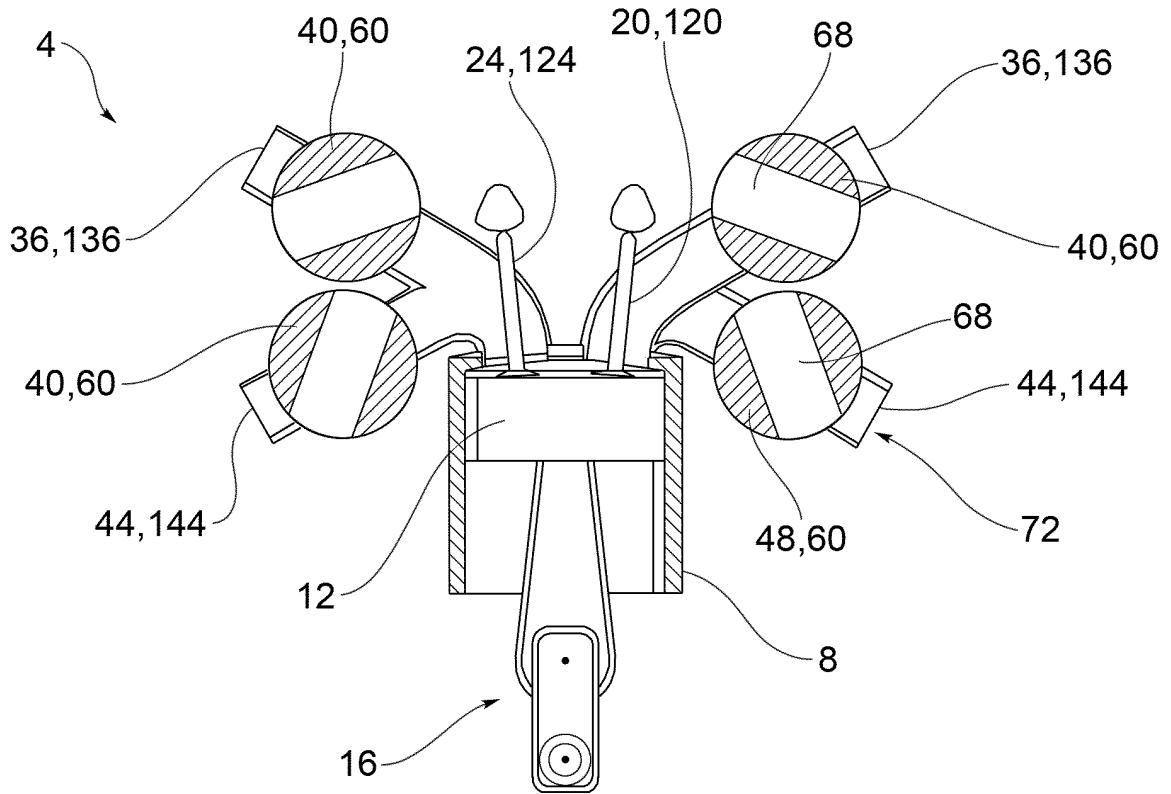

FIG. 4

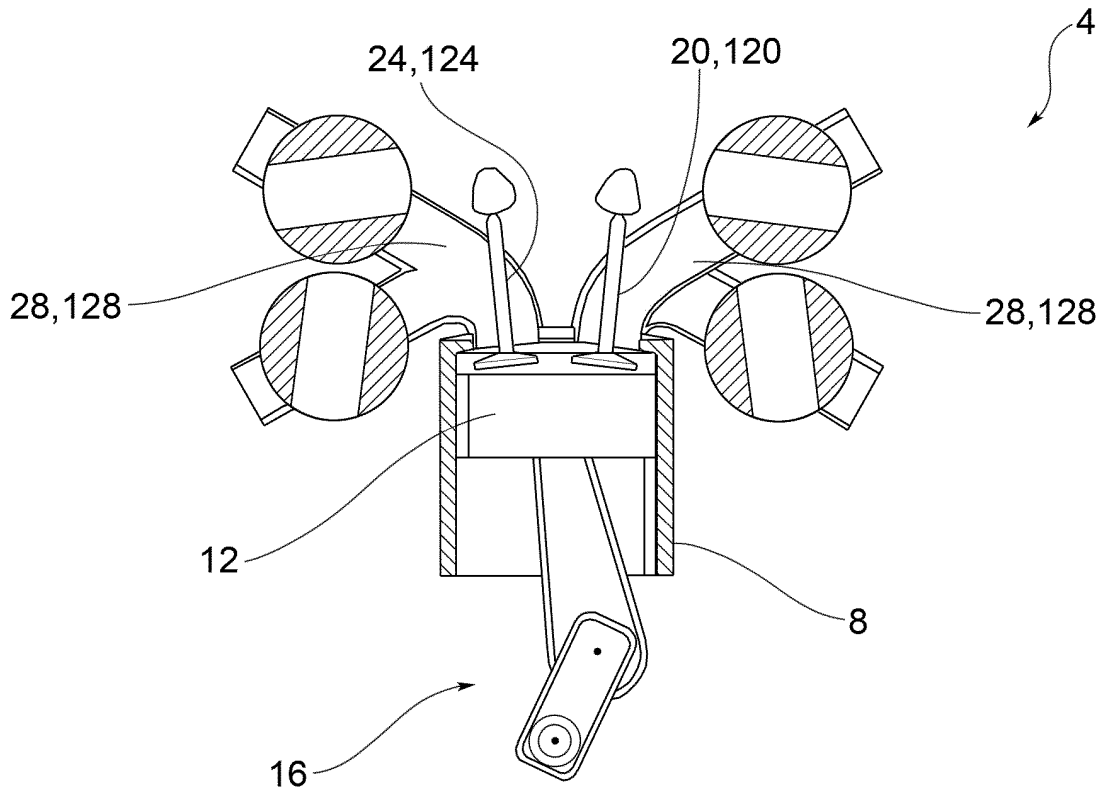

FIG. 5

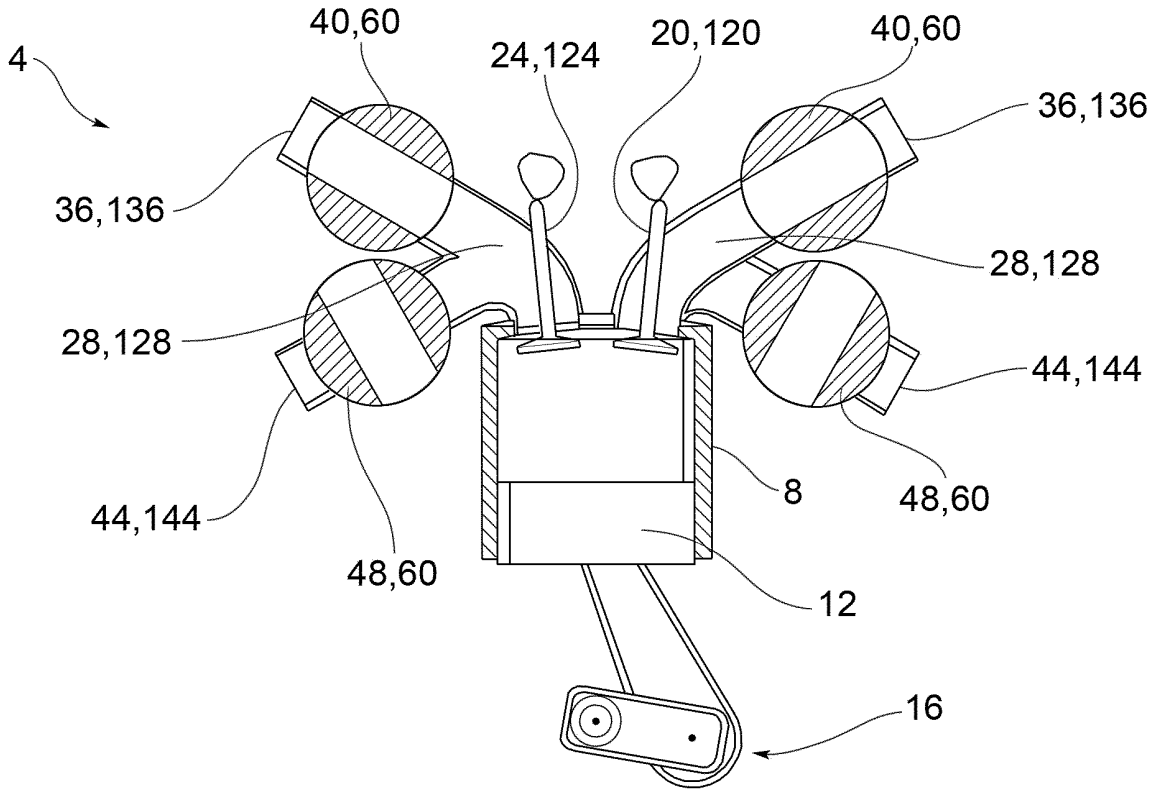

FIG. 6

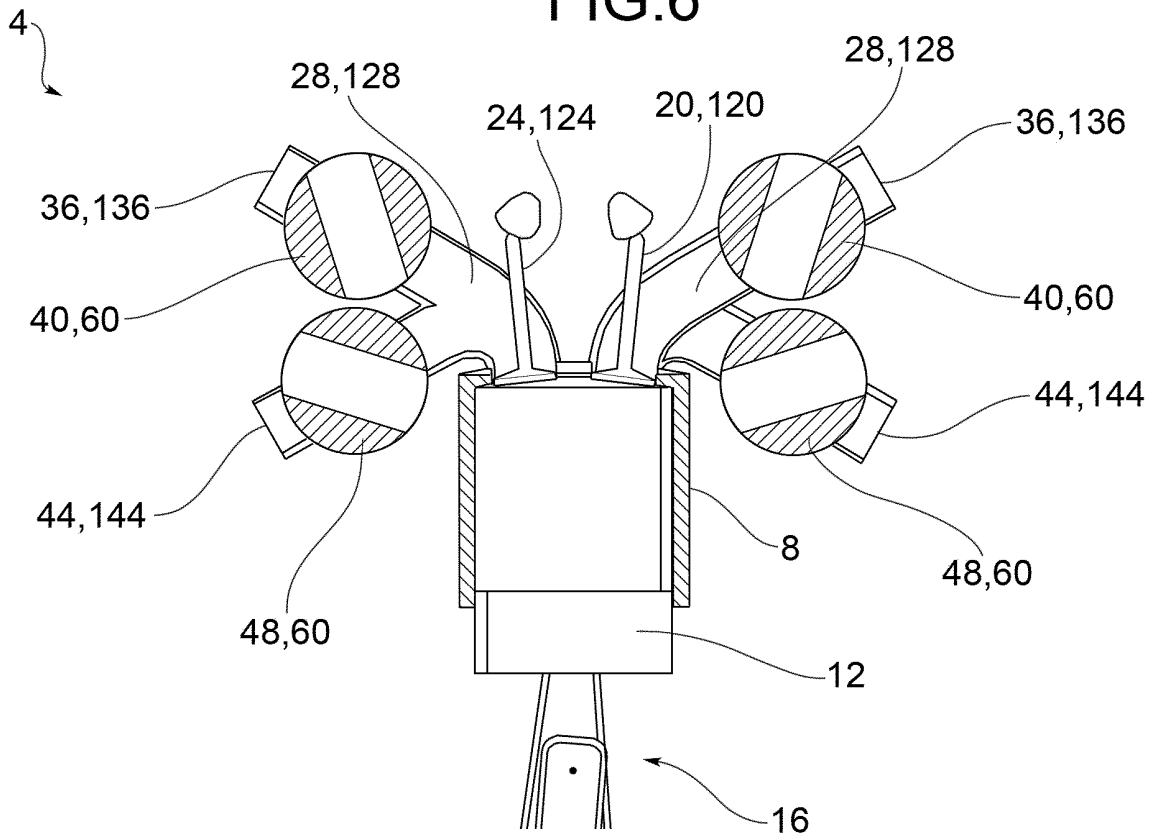

FIG. 7

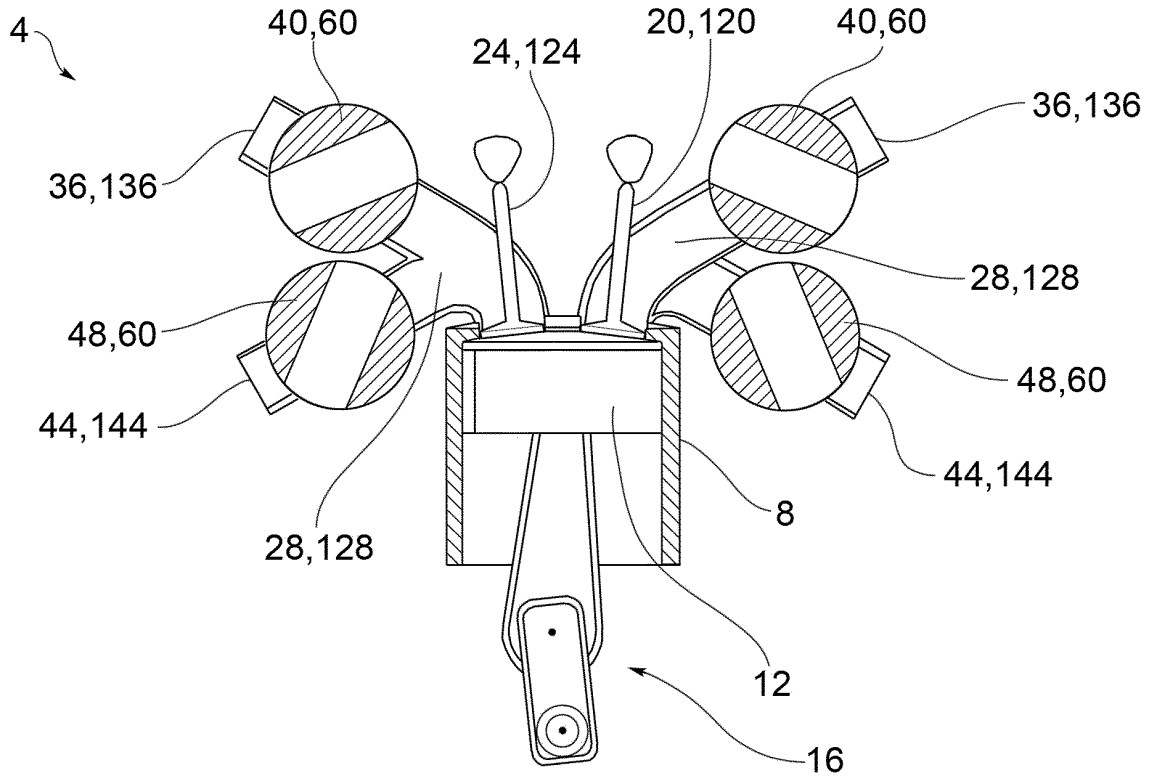

FIG. 8

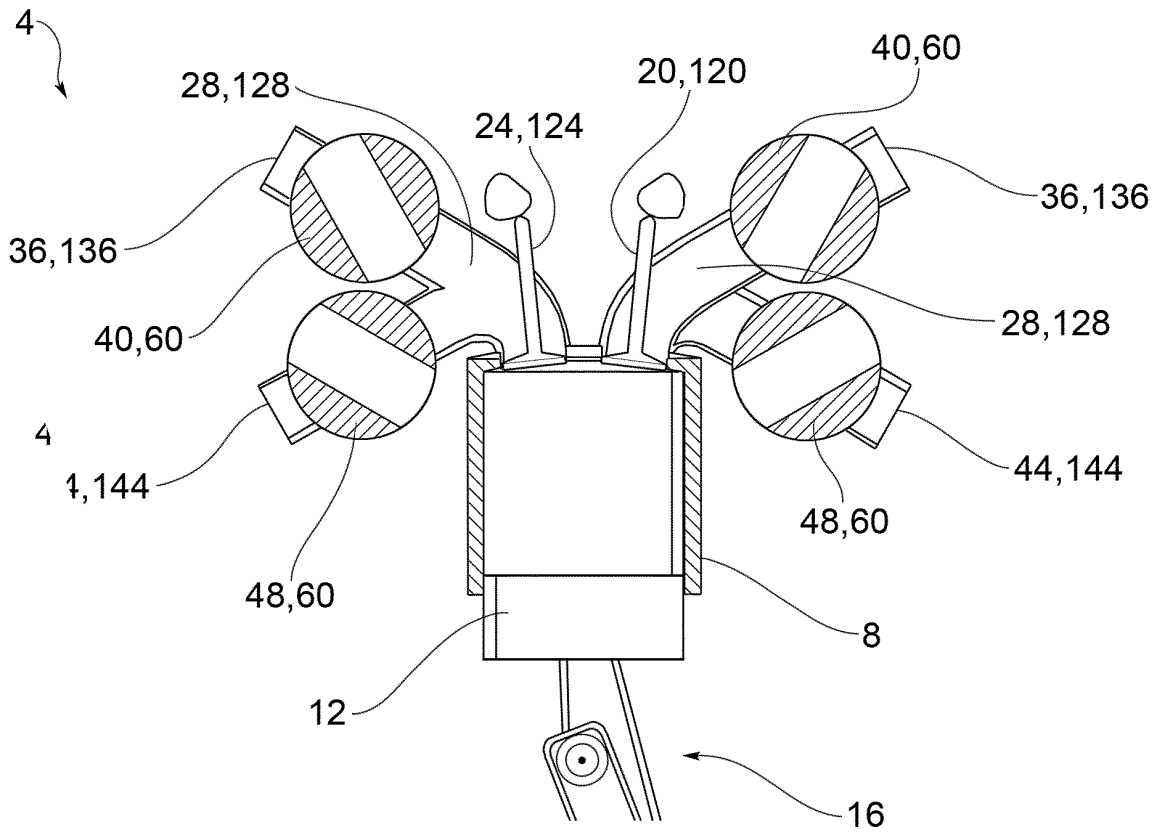

FIG. 9

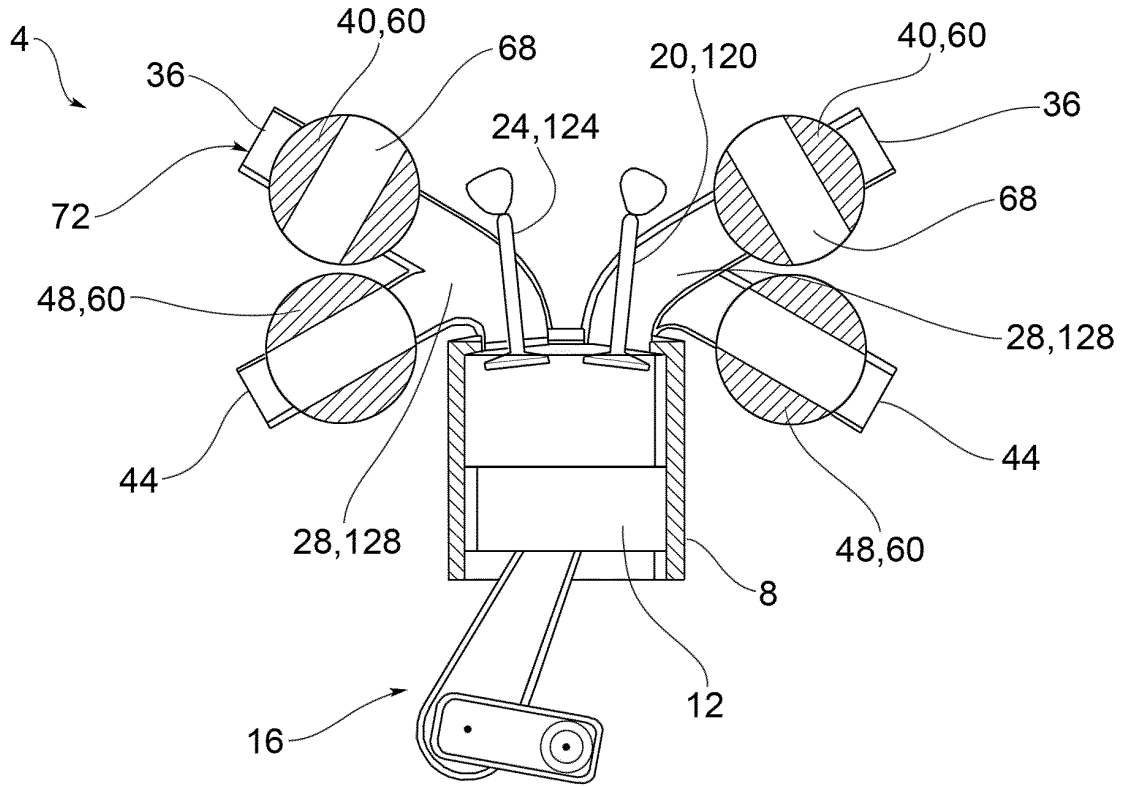

FIG. 10

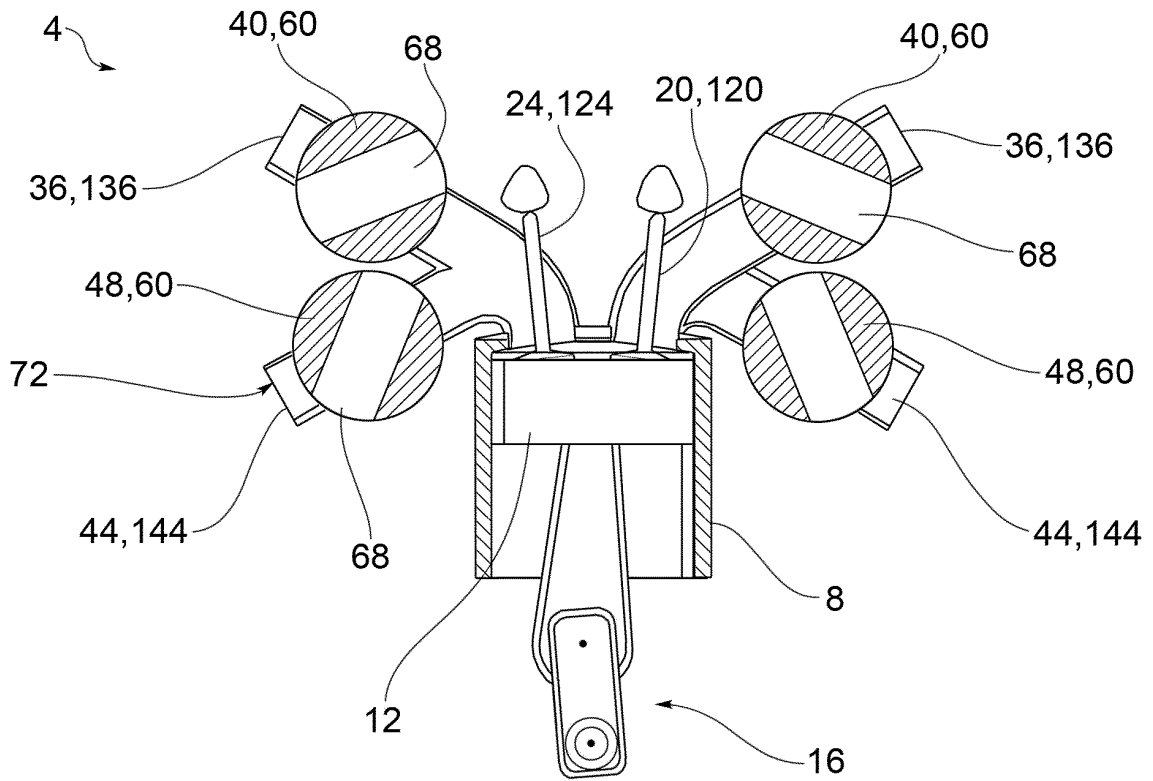

FIG. 11