

(19) World Intellectual Property Organization
International Bureau



(43) International Publication Date
9 July 2009 (09.07.2009)

PCT

(10) International Publication Number
WO 2009/083943 A1

(51) International Patent Classification:
G01N 35/00 (2006.01) A61M 39/10 (2006.01)

(74) Agents: FISHER, Michal et al.; Webb & Associates, P.O. Box 2189, 76121 Rehovot (IL).

(21) International Application Number:
PCT/IL2007/001632

(81) Designated States (unless otherwise indicated, for every kind of national protection available): AE, AG, AL, AM, AO, AT, AU, AZ, BA, BB, BG, BH, BR, BW, BY, BZ, CA, CH, CN, CO, CR, CU, CZ, DE, DK, DM, DO, DZ, EC, EE, EG, ES, FI, GB, GD, GE, GH, GM, GT, HN, HR, HU, ID, IL, IN, IS, JP, KE, KG, KM, KN, KP, KR, KZ, LA, LC, LK, LR, LS, LT, LU, LY, MA, MD, ME, MG, MK, MN, MW, MX, MY, MZ, NA, NG, NI, NO, NZ, OM, PG, PH, PL, PT, RO, RS, RU, SC, SD, SE, SG, SK, SL, SM, SV, SY, TJ, TM, TN, TR, TT, TZ, UA, UG, US, UZ, VC, VN, ZA, ZM, ZW.

(22) International Filing Date:
31 December 2007 (31.12.2007)

(25) Filing Language: English

(26) Publication Language: English

(71) Applicant (for all designated States except US): **ORID-ION MEDICAL (1987) LTD.** [IL/IL]; Hamarpe 7, Har-Hotzvim, 91450 Jerusalem (IL).

(84) Designated States (unless otherwise indicated, for every kind of regional protection available): ARIPO (BW, GH, GM, KE, LS, MW, MZ, NA, SD, SL, SZ, TZ, UG, ZM, ZW), Eurasian (AM, AZ, BY, KG, KZ, MD, RU, TJ, TM), European (AT, BE, BG, CH, CY, CZ, DE, DK, EE, ES, FI, FR, GB, GR, HU, IE, IS, IT, LT, LU, LV, MC, MT, NL, PL, PT, RO, SE, SI, SK, TR), OAPI (BF, BJ, CF, CG, CI, CM, GA, GN, GQ, GW, ML, MR, NE, SN, TD, TG).

(72) Inventors; and

(75) Inventors/Applicants (for US only): **COLMAN, Joshua Lewis** [IL/IL]; 7/3 Petel Street, Jerusalem (IL). **BOTE-SAZAN, Zion** [IL/IL]; Ramat Hagolan 48/13, Jerusalem (IL). **ITZHAK, Gal** [IL/IL]; 58/111 Betlehem street, Talpiot, Jerusalem (IL).

Published:
— with international search report

(54) Title: TUBE VERIFIER

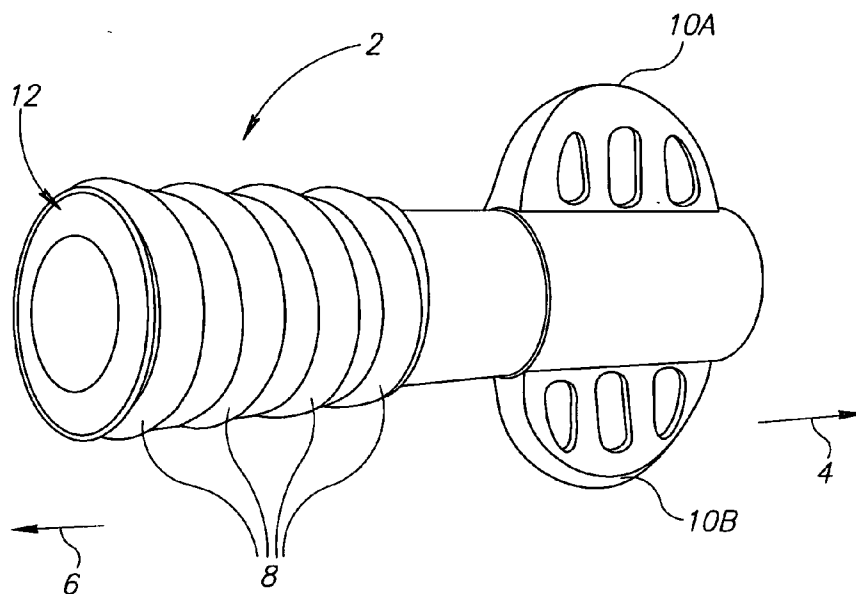

FIG. 1

(57) Abstract: There is provided a tube connector for connecting between a fluid sampling tube and a fluid analyzer, the tube connector includes an end face adapted to identify the tube connector, said end face comprising a reflecting surface having one or more reflective regions adapted to reflect light at a predetermined range of wavelengths.

WO 2009/083943 A1

TUBE VERIFIER

BACKGROUND

5

Various analyzing devices, such as, for example, medical devices, use various types of connectors that are used as mediators for connecting between the medical device interface (the instruments itself) and external constituents, such as tubes, cannules, and the like that may be of the disposable type. An example of such medical device is a capnograph, which is an instrument for analyzing exhaled breath. A capnograph samples air that is exhaled by a subject by using a small tube, also known as sample line. One end of the sample line may be connected to an air passageway of a respirator or to a cannula attached to, for example, the subject nostril. The other end of the sampling line is connected, through a connector to the instrument itself. The sampling line, including the tube, the connector and other constituents, such as filters, and the like is, in most cases disposable and is replaced for each patient and for each patient type. For example, a subject which is a child will have a sampling line which is different (for example, in size) than a sampling line of an adult subject.

20

In general, the shape of a connector is standardized throughout the industry, such that tube assemblies of various manufacturers may be interchangeably used with any analyzing instrument. Hence, the manufacturer of a particular type of analyzing instrument has generally no control over which type of tube is used with his instrument. Therefore, to ensure optimal functioning of the instrument, and for commercial reasons, the manufacturer of an analyzing instrument may want to exert such control. In particular, he may want to stipulate that only a certain class, type and/or model of tube assemblies be connected to, and used with, his instrument. Such a class may, for example, consist of tube assemblies that include a specific constituent, such as, for example, a filter, or such that are manufactured directly by him or to his specifications or under his supervision or license.

30

Enforcing such stipulation may be performed by various means, such as, for example, by using a unique interlocking key arrangement between the connector and

35

the instrument; having a system by which the correct tube assembly would be identified as such by the instrument, whereupon its operation would be enabled, and to disable the instrument otherwise, such as for example, by using electro-mechanical fitting, electrical fitting, and the like. Benefits of such arrangement would be that the instrument would be prevented from operation also when no tube is connected at all or when even a correct tube is improperly connected, thus avoiding damage to sensitive parts of the instrument and also causing incorrect readings. Yet another purpose may be served by such a system, namely identifying the tube assembly as belonging to one of a number of classes and informing the instrument of the particular identity detected, so as to enable it to automatically operate differently for the different classes.

There is thus a widely recognized need for, and it would be highly advantageous to have, a fluid analysis system that includes the capability of determining that a tube assembly has been properly connected to the analyzing instrument and that the tube is of a certain class. Such a capability should be compatible with the standard shape of connectors being used, as well as with the medical environment, and should be reliable and inexpensive.

20

SUMMARY

The following embodiments and aspects thereof are described and illustrated in conjunction with systems, tools and methods which are meant to be exemplary and illustrative, not limiting in scope. In various embodiments, one or more of the above-described problems have been reduced or eliminated, while other embodiments are directed to other advantages or improvements.

30

Medical analyzing devices may use various types of connectors that may be used for connecting between the medical device and external constituents, such as tubes, cannules, and the like that are usually disposable and are replaced for each patient. In general, the shape of a connector is standardized, such that tube assemblies

of various manufacturers may be interchangeably used with any analyzing device. However, to ensure optimal functioning of the device and for commercial reasons, the manufacturer of an analyzing device may want to stipulate that only a certain class, type and/or model of tube assemblies be connected to and used with his instrument.

5 Such stipulation may be achieved by having an identification and verification means between the medical device and the tube attached to the device. Such capability of determining that a tube assembly has been properly connected to the analyzing instrument and that the tube is of a certain class may further ensure optimal functioning of the medical device. Moreover, the identification and verification

10 means may include any type of information that may be encoded on the end face of the tube connector and identified by the medical device. Accordingly, there is thus provided, according to some embodiments, one or more identification and verification means that may allow increased amount of information to be encoded on the end face of the connector and transferred between the connector and the device. The

15 information encoded may improve the safety of using the device, simplify the use of the device and optimize the use of the device by ensuring an optimal operating mode of the device in accordance with the tube connector (and hence the tube/sampling line) attached to the device. For example, the information encoded on the end face of the connector may be used to determine the type/class and/or model of the connector,

20 such as for example the patient interface, patient size, patient specific parameters, and the like. For example, the information may be used to determine if the connector type is a children's connector (a connector of sampling line that is to be used with children), an adult connector (a connector of sampling lines that is to be used with adults), and the like. This information may be used by the medical device to

25 determine the optimized mode of operation for that type/class/model/manufacturer of connectors and patient interface. This may be achieved, for example, by use of optimized software algorithm to be used for that type of connector and sampling line.

According to some embodiments, there is provided a tube connector for

30 connecting between a fluid sampling tube and a fluid analyzer, the tube connector includes an end face adapted to identify the tube connector, said end face comprising a reflecting surface having one or more reflective regions adapted to reflect light at a predetermined range of wavelengths.

According to some embodiments, the surface of the tube connector may be adapted to reflect light at one or more distinct wavelengths. The surface may further be adapted to selectively reflect light having different intensities. The surface may further include one or more reflective regions having distinct reflective properties.

5 The surface may be patterned, wherein the pattern may include geometrical shapes, non-geometrical shapes, horizontal lines, vertical lines or any combination thereof.

According to some embodiments, the fluid analyzer to which the tube connector is connected to may include a capnograph.

10

According to further embodiments, the fluid analyzer may include a verification system adapted to identify the connector, wherein the verification system may include one or more light sources and one or more optical detectors. The one or more light sources may include a light emitting diode (LED), a lamp or any combination thereof. The one or more optical detector may include an RGB detector.

15

According to other embodiments, the end face of the tube connector may further include a Radio Frequency Identifier (RFID) tag adapted to provide further identification of the connector type. The end face of the tube connector may further include a barcode tag adapted to provide further identification of the connector type.

20

According to additional embodiments, the verification system of the fluid analyzer may further include a Radio Frequency Identifier (RFID) reader, a barcode scanner or both.

25

According to some embodiments there is provided a device for analyzing fluid, the device includes: a device connector adapted to receive a tube connector and a verification system for identifying the tube connector, wherein said system comprises one or more light sources adapted to transmit light towards an end face of the tube connector, one or more optical detectors adapted to detect reflected light from the end face and to produce a signal indicative of the reflected light and a processor adapted to identify the tube connector type based on a signal received from the detector.

30

According to some embodiments, the tube connector is adapted to connect between a fluid sampling tube and the fluid analyzer.

According to additional embodiments, the end face of the connector includes a reflecting surface having one or more reflective regions adapted to reflect light at a predetermined range of wavelengths. The end face surface may be adapted to reflect light at one or more distinct wavelengths. The surface may be adapted to selectively reflect light having different intensities. The surface may include one or more reflective regions having distinct reflective properties. The surface may further be patterned, wherein the pattern may include geometrical shapes, non-geometrical shapes, horizontal lines, vertical lines or any combination thereof.

According to additional embodiments, the fluid analyzing device may include a capnograph. The one or more light sources of the verification system may include a light emitting diode (LED), a lamp or any combination thereof. The one or more optical detector of the verification system may include an RGB detector.

According to other embodiments, the end face of the tube connector may further include a Radio Frequency Identifier (RFID) tag adapted to provide further identification of the connector type. The end face of the tube connector may further include a barcode tag adapted to provide further identification of the connector type.

According to additional embodiments, the verification system of the fluid analyzer may further include a Radio Frequency Identifier (RFID) reader, a barcode scanner or both.

According to some embodiments, there is provided a verification system for identifying a tube connector attached to a fluid analyzer, the system includes one or more light sources adapted to transmit light towards an end face of the tube connector; one or more optical detectors adapted to detect reflected light from the end face and to produce a signal indicative of the reflected light; and a processor adapted to identify the tube connector type based on a signal received from the detector.

According to additional embodiments, the verification system may be functionally associated with a device connector adapted to receive the tube connector.

According to additional embodiments, there is further provided a method for identifying a tube connector type attached to a fluid analyzer, the method includes transmitting light from one or more light sources towards an end face of the tube connector; detecting reflected light from the end face by one or more optical detectors, producing a signal indicative of the reflected light and identifying the tube connector based on the signal.

In addition to the exemplary aspects and embodiments described above, further aspects and embodiments will become apparent by reference to the figures and by study of the following detailed descriptions.

BRIEF DESCRIPTION OF THE FIGURES

Examples illustrative of embodiments of the disclosure are described below with reference to figures attached hereto. In the figures, identical structures, elements or parts that appear in more than one figure are generally labeled with a same numeral in all the figures in which they appear. Dimensions of components and features shown in the figures are generally chosen for convenience and clarity of presentation and are not necessarily shown to scale. The figures are listed below.

Fig. 1 – A perspective view of a connector, according to some embodiments;

Fig. 2A-K – A front view of exemplary end face patterns of a connector, according to some embodiments; and

Fig. 3 – A perspective schematic of a closeup side view of a connector and verification system, according to some embodiments.

DETAILED DESCRIPTION

In the following description, various aspects of the disclosure will be described. For the purpose of explanation, specific configurations and details are set forth in order to provide a thorough understanding of the disclosure. However, it will also be apparent to one skilled in the art that the embodiments may be practiced without specific details being presented herein. Furthermore, well-known features may be omitted or simplified in order not to obscure the invention.

10 According to some embodiments, there is provided an end face of a connector, the surface of which may have an annular, ring like shape. The surface of the end face of the connector may be an integral part of the connector, or may be permanently attached to the connector. The surface may include a flat, uniform surface. The surface may include a concave and/or convex surface. The surface may include a
15 patterned surface, wherein the patterns may include recurring patterns of any desired shape. The surface may be a discontinuous surface. The surface may be divided to various regions/areas, wherein at last two areas have different characteristics. By characteristics may include different texture, different compositions, different chemical properties, different optical properties, different electrical properties,
20 different magnetic properties, different surface concaveness, and the like.

According to some embodiments, there is provided a connector, such as a tube connector that may be used to connect a tube to a medical device, such as for example a capnograph. Reference is now made to Fig. 1, which illustrates a perspective view
25 of a connector, according to some embodiments. The connector, such as connector (2), may include 2 ends: a tube end (4), which is the end that may be connected to a tube; and a device end (6), which is the end that may be used to connect the connector to a device/instrument. Connector, such as, connector (2) may be a male or a female type connector that may be received/connected/attached/ to a matching female or male
30 connector (referred to herein as a "device connector"), respectively, located on the device, such as, for example, on the device panel. The connector, such as connector (2), may have an elongated cylindrical-like shape. Spiral threads, such as threads (8), may be found at the outer surface of the connector in close proximity to the device end (6) of the connector (2) and may be used to secure the connector to its matching

connector on the device (the device connector). At the tube end (4) of the connector (2), gripping wings, (such as, gripping wings 10A-B in Fig. 1) are located. The end face (12) of the device end (6) of the connector (2) may have a circular, annular shape. The end face may form as an integral part of the connector (2), or may be an external surface that is permanently attached to the device end (6) of the connector (2). The end face (12) surface may be a continuous or discontinuous surface, which may include at least two regions/areas that are distinct from each other. By distinct from each other may relate to physical, mechanical, electrical, optical, and chemical properties, such as, for example, but not limited to: shape, pattern, texture, color, size, electrical properties, reflectivity, composition, magnetic properties, and the like, and any combination thereof. The distinct regions of the end face of the connector may be used as an identifying means to the medical device to which the connector is to be connected and consequently to affect a decision process in the device and hence the operation mode of the medical device. The distinct regions of the end face of the connectors may be used to encode data that may be read/identified and used by the medical device. The encoded data may include, for example, the type/class of the connector, the model of the connector, manufacturer of the connector, preferred mode of operation with that connector, and the like.

Prior art, such as that described in US 6,437,316 teaches that the annular end face of the device end may be specularly reflective to light. The reflectivity may be obtained, for example, by coating the surface with a suitable reflective layer, by polishing the surface to a glossy, by hot-pressing a reflective foil and the like. In particular, the reflective surface need not extend over the entire width of the end face, but it must form a complete annular ring. However, such a connector may be identified by the device by only one verification way (meaning- reflection of light at one range of wavelengths). There is thus a need to combine additional verification ways in order to allow the connector to be used with various types/models of devices and also to allow increased amount of information to be encoded on the end face of the connector and transferred between the connector and the device. This may allow a more accurate, efficient, simple and safer mode of operation of medical device.

As referred to herein, the term “the end face of the connector” relates to the end face of the device end of a connector, such as connector 2 of Fig. 1, unless otherwise stated.

5 As referred to herein, the terms “amplitude” and “intensity” may interchangeably be used.

As referred to herein the term “type”, “model”, “class” of the connector may interchangeably be used and may relate to the interface to be used with the tube
10 connector and/or manufacturer of the tube connector.

According to some embodiments, the end face of the connector may include more than one region with distinct reflectivity characteristics. The regions may be adjacent to each other or may be spatially separated. Each of the regions may be
15 reflective at a different range of wavelength and/or possess different level (amplitude, intensity) of reflectivity and/or may be non-reflective (such as, for example, colored black, which absorb all light and does not reflect back). For example, the end face may include two spectrally distinct reflective regions. Each of the regions may
20 comprise about half of the annular circumference of the end face. For example, one region may be spectrally reflective such that when light is emitted at the end face, this region may reflect at one amplitude, while the second region may reflect at a second amplitude. For example, one region may be spectrally reflective such that when light
25 is emitted at the end face, this region may reflect light at one wavelength (for example, at the green color range of wavelength), while the second region may reflect light at a second wavelength (for example, at the red color range of wavelengths). The reflected lights may be detected by matching detectors located in the medical device and then further processed/analyzed to confirm the connection between the
30 connector and the medical device, as further detailed below herein. The distinct regions of reflectivity of the connector end face may be coated or comprised of various materials that possess different reflectivity characteristics. For example, the distinct regions may have reflective materials that contain dyes or pigments. For example, the distinct regions may be coated with suitable spectral filters. For example, the distinct regions may have different surface areas, such as, for example, a flat surface, a concaved surface, a convex surface or any combination thereof.

According to some embodiments, in addition to determining various wavelength ranges of reflectivity of connectors with more than one reflective region at their end face, the amplitude and the threshold levels of reflectiveness may also be determined. The threshold levels of reflectiveness may be used as an additional data encoding means that may be used to distinguish between various types/models of connectors. For example, a connector that exhibits reflectivity of above a predetermined threshold value may belong to a certain type of connector (for example, connectors of sampling lines that are to be used with children), while connectors with a lower threshold (that may include, for example, at least two distinct regions of reflectivity at the connector end face) may belong to a different type of connector (for example, connectors of sampling line to be used with adults). For example, the threshold levels may be used to distinguish between connectors manufactured by different manufacturers.

15

According to further embodiments, the end face of the connector may include various patterns that may be distinguished by their characteristics/properties. The patterns may include any shape, such as geometrical shapes (such as circles, triangles, squares, and the like), non-geometrical shapes, such as hearts, droplets, waves, and the like. The patterns may further include any combination of shapes. The shapes may include any size and any number of shapes that may be distributed evenly or non-evenly over the surface of the end face of the connector. The patterns may include recurrent patterns. The patterned regions on the surface of the end face connector may exhibit different characteristics than the non-patterned region surface. Different characteristics may include, for example, optical characteristics, such as, for example, various reflectiveness properties.

20
25

According to additional embodiments, the end face of the connector may include any combination of lines, dots, spots and the like that may be distributed evenly or non evenly over the surface of the end face of the connector. For example, the lines may include straight lines, curved lines, checkered lines, and the like. Areas/regions defined by the combination of lines may possess different characteristics than other regions. Different characteristics may include, for example, optical characteristics, such as, for example, various reflectiveness levels, various

30

wavelength ranges of the reflected light, and the like. According to further embodiments, the surface of the end face of the connector may include one or more concave regions and one or more convex regions. The concave regions may focus the reflected light and the convex regions may defocus the reflected light and thus different levels of reflectivity from different regions of the end face of the connector may be obtained.

Reference is now made to Figs. 2A-K, which illustrate exemplary end faces of a connector according to some embodiments. For example, end face A illustrates an annular end face of a connector with two regions with distinct reflective properties. For example, end face B illustrates an annular end face divided into three equal regions, wherein at least one of the regions has distinct reflective properties. For example, end face C illustrates an annular end face divided into four equal regions, wherein at least one of the regions has distinct reflective properties. For example, end face D illustrates an annular end face of a connector with a reflective surface and spots, at least one of which is with distinct reflective characteristics. For example, end face E illustrates an annular end face of a connector with a reflective surface and circles distributed over the surfaces, at least one of the circles exhibits distinct reflective characteristics. For example, end face F illustrates an annular end face of a connector with a reflective surface and heart shaped regions distributed over the surfaces, at least one of the heart shaped regions exhibits distinct reflective characteristics. For example, end face G illustrates an annular end face of a connector with a reflective surface and squares distributed over the surfaces, at least one of the squares exhibits distinct reflective characteristics. For example, end face H illustrates an annular end face of a connector with a reflective surface and horizontal lines stretched over the surface, at least one of the areas bound between the lines exhibits distinct reflective characteristics. For example, end face I illustrates an annular end face of a connector with a reflective surface and horizontal and vertical lines distributed over the surface, at least one of the areas bound between the lines exhibits distinct reflective characteristics. For example, end face J illustrates an annular end face of a connector divided into two separate, non-continuous regions, wherein at least one of the regions has distinct reflective properties. For example, end face K illustrates an annular end face of a connector divided into three separate, non-continuous regions, wherein at least one of the regions has distinct reflective

properties. For example, end face L illustrates an annular end face of a connector divided into four separate, non-continuous regions, wherein at least one of the regions has distinct reflective properties.

5 According to some embodiments, the medical device may include a verification system that may be used to detect/identify the connector (and hence the tube) attached to the medical device. Identification/detection of the connector that is attached to the medical device may be performed by detection/identification of any of the properties/parameters of the end face of the connector that are described herein.

10 For example, the verification system of the medical device may detect/identify the optical properties (as determined by the reflectiveness properties) of the end face of the connector. The verification system may include one or more optical light source emitters (such as, for example, Light Emitting Diodes (LEDs)) that may emit light at various individual wavelengths and/or at a wide spectral range of wavelengths. For

15 example, the light source may include a Light Emitting Diode (LED) that may emit light at the visible white light spectral range (for example, at the range of 0.4 to 0.7mm). The verification system may further include one or more optical receivers that may be adapted to receive light reflected from the end face surface of the connector. The optical receivers may be spatially separated from the light source

20 emitters so as to ensure that light detected by the optical receivers is the light reflected from the end face surface of the connector. Spatial separation may be performed, for example by placing an optical barrier between the light source and the optical receiver. The spatial separation may be performed, for example, by use of optical wave guides that may be used to create a channel/chamber, at the bottom of which the

25 optical detector is situated. The use of such a chamber may ensure that only light that is reflected from the end face surface of the connector reaches the optical receiver, while light, such as scattered light from the environment, direct light from the light source, and the like, is prevented from reaching the optical detector. The reflected light from the end face of the connector may be at various wavelengths and at various

30 amplitudes (intensity levels), which may be determined by the reflective properties of the surface of the end face connector. The optical receiver may include any type of light and/or color detector. The optical receiver may include more than one optical receiver, which may be adapted to receive light at the wavelengths, which correspond to the wavelengths of the light reflected from the various regions of the end face of

the connector. For example, the optical receiver may include one or more light detectors that may be used to detect intensity of reflected light. The optical receiver may include a light detector that may be further equipped with an optical filter that may allow the optical detector to identify a specific, predetermined range of wavelengths that correspond to the optical filter. For example, the optical detector may include an RGB detector, which is well known in the art. Briefly, an RGB detector may be basically described as a multi-element photodiode coupled to red, green, and blue filters, that enable the photodiode to generate separate response curves for the three colors and hence determine the color (wavelength) and the amplitude (intensity) of the light detected by the photodiode. As such, the RGB color detector that may be used to detect light of various wavelengths (which correspond to different colors) may be reflected from one or more surfaces of the end face of the connector. The RGB detector may further be used to detect the amplitude (level) of the reflected light from one or more surfaces of the end face of the connector. According to additional embodiments, the optical receiver may be adapted to receive light at a wavelength which corresponds to the wavelength of the light reflected from a region of the end face of the connector and to further receive light at a second wavelength, which may correspond to the wavelength of the light reflected from other region(s) of different reflectivity of the end face surface. According to other embodiments, the light reflected from the regions of different reflectivity on the surface of the end face of the connector may be conveyed by the use of, for example, optical fibers that may collect the signals reflected from the individual spots into one optical signal that may be received by the second receiver.

Reference is now made to Fig. 3, which illustrates a schematic drawing of a close up side view of an end face of a tube connector and the medical device verification system, according to some embodiments. As shown in Fig. 3A, verification system 100, includes one or more light sources (shown as one light source, 102). The light source may include, for example, a LED that may emit light in the white light spectral range. The verification system further includes one or more optical receivers (shown in Fig. 3A as one optical receiver, 104). The optical receiver may include, for example an RGB detector. The verification system may further include an optical barrier, such as optical barrier 106, that may be used to prevent light emitted from a light source (such as light source 102) from directly reaching the

optical receiver (such as optical receiver 104). Also shown in Fig. 3A, the end of connector, (such as connector 108) and the end face surface of the connector, (end face 110). When operating, the verification system light source may emit light (illustrated as arrow 112). The light emitted from the light source may be reflected (illustrated as reflected light (arrow 114)), depending on the reflectiveness properties of the connector end face (110). Reflected light 114 may reach the optical receiver 104, that may consequently determine the optical properties of the reflected light (such as color (wavelength) and amplitude (intensity)). According to the determined optical properties of the reflected light, the verification system (as detailed below herein) may determine the type/model of the connector attached and further determine the operation mode of the medical device. As shown in Fig. 3B, verification system 200, may include one or more light sources (shown as one light source, 202). The light source may include, for example, a LED that may emit light at the white light spectral range. The verification system further includes one or more optical receivers (shown in Fig. 3B as one optical receiver, 204). The optical receiver may include, for example an RGB detector. The verification system may further include one or more optical guides, such as optical guides 206A-B that may form a tunnel/chamber, such as chamber 209, at the bottom of which, optical receiver (204) is positioned. The optical guides may be used to prevent light emitted from a light source (such as light source 202) from directly reaching the optical receiver (such as optical receiver 204), as well as other light that is not reflected from the connector end face. Also shown in Fig. 3B is the end of connector, (such as connector 208) and the end face surface of the connector, end face 210). When operating, the verification system light source may emit light (illustrated as arrow 212). The light emitted from the light source may be reflected (illustrated as reflected lights (arrow 214A-B)), depending on the reflectiveness properties of the connector end face (210). Only light that is reflected at an acute angle (such as reflected light 214A) may enter chamber 209 and reach the optical receiver. Other reflected light (such as 214B) is prevented from reaching the optical receiver. Likewise, light that may originate from other sources, such as scattered light from the environment (demonstrated as arrow 216) is prevented from reaching the optical receiver. The optical receiver that may consequently determine the optical properties of the detected reflected light (such as color (wavelength) and amplitude (intensity)). According to the determined optical properties of the reflected light, the verification system (as detailed below herein) may determine the type/model

of the connector attached and further determine the operation mode of the medical device. Additional elements/constituents of the verification system that are detailed below herein, such as wires, fibers, power sources, electrical circuits, comparators, integrators, and the like are omitted from drawings 3A and 3B for clarification purposes.

According to some embodiments, and as mentioned above herein, the medical device may include a verification system that may be used to de-encode the data encoded on and by the end face of the connector. The verification system may be used to analyze the properties and characteristics of the connector attached to the medical device, and accordingly change the mode of operation of the device. For example, in relation to detection of reflected light by the end face of the connector, the medical device may include the various electrical circuits that may further include various constituents for generating and processing optical signals transmitted to the connector end face and received therefrom and based upon the analyzed results determine if the connector is properly connected to the medical device and identify what is the type, class, model and/or interface of the connector (and hence the tube attached thereto). According to some embodiments, the electronic circuits may include several constituents, such as, for example, but not limited to: one or more light sources (such as, for example, LED adapted to emit light at various wavelengths, Infra Red light source, Ultraviolet light source, laser light source, and the like); photodiodes adapted to receive emitted and reflected light and convert the signal to electrical signal; RGB detector; fibers, such as optical fibers adapted to transfer light (emitted and reflected) between the medical device and the connector; one or more amplifiers adapted to specifically amplify the light reflected from the connector end face; filters, adapted to emit and/or receive reflected light of a specific wavelength; one or more synchronous detectors adapted to synchronize light pulses emitted from the one or more light sources, respectively; one or more integrators adapted to receive a voltage signal from the one or more synchronous detectors and integrate the voltages over a certain time period to yield voltage values (for each of the light sources); one or more comparators/processors which are adapted to compare/process the voltage value obtained by the one or more integrators to predetermined threshold values that correspond to the various light reflections from the connector. The one or more processors may be adapted to process the information received from the detectors and

to provide identification of the tube connector based on the signals received from the detector. The one or more comparators/processors may yield a signal that may be used by the medical device to determine if the connector is properly attached to the device and if the connector is of the right type, class and/or model and accordingly
5 modify the operation of the medical device. If, for example, the binary signal received indicates that improper connection is detected between the device and the connector, the device may not operate until the attachment is corrected. For example, if the signal indicates that the connector is attached to a sampling line (tube) adapted for children, than the device may operate accordingly and be adjusted (for example,
10 automatically) to operate under "children" mode. For example, if the calculated/measured signal is indicative that the connector is attached to a sampling line that is to be used with intubated patients, the device may operate accordingly and be adjusted to operate under "intubated patient" mode. In addition, the verification system of the medical device may further include one or more additional
15 detectors/receivers that may be used to detect/ sense/ measure/ receive additional features/ characteristics/ properties/ information that may be encoded on and by the end face of the connector, as further detailed below herein.

According to some embodiments, the identification of the connector (and
20 hence the tube) being attached to the medical device may be performed in various ways, such as, for example, while the connectors are being attached ("on the "fly"), after the connectors have been attached ("final position") or any combination thereof. For example, the identification (and verification) of the tube connector being attached may be performed on the fly, during the attachment (connection) of the tube
25 connector to its corresponding connector on the device. The connection may be performed, for example by pushing and/or turning and/or screwing the tube connector to its location in the device connector. During the time of insertion, the tube connector may be identified by the verification system by any of the methods described herein, such as, for example, by identifying distinct regions of reflectivity
30 (amplitude and/or wavelength) of the end face of the connector; by identifying recurring changes of reflectivity during the revolving of the tube connector relative to the device connector, and the like. The identification (and verification) of the tube connector attached to the device may be performed after the tube connector is attached to its respective device connector, while the connectors are at their final

(resting) position. Such identification may be performed by the verification system of the medical device by any of the methods described herein.

According to some embodiments, the relative final location (alignment) of the end face of the connector with respect to the detectors/receivers of the verification system of the medical device may be determined. For example, the relative location (alignment) of the end face of the connector with respect to its matching device connector may be determined. Determining a desired relative location of the end face of the connector to its matching device connector may be used to allow proper alignment between the respective locations of the two connectors and hence, a desired respective location between the end face of the connector to the verification system of the medical device. Proper alignment may be used to allow matching between regions of the end face of the connector and, for example, respective receivers/detectors (such as, for example, optical receivers) of the verification system of the medical device. Determination of the desired relative location (alignment) between the end face connector and the verification system of the medical device may be performed by various means, such as, for example but not limited to physical barriers, mechanical fitting, visual fitting, manual fitting, and the like. For example, proper alignment may be achieved by matching projection(s) and depression(s) on the end face connectors and its matching device connector; key and lock fittings on the end face connector and its matching device connector; markings on the end face connector and its matching device connector, to which it is to be attached, and the like. For example, the end face connector may include projection at the circumference of the device end of the connector. The device connector may include a matching depression. In order to physically attach the two connectors, the respective projection and depression must match. Matching the respective projections and depression of the connectors ensures the proper relative alignment of the end face of the connector with the corresponding receivers/detectors of the verification system of the medical device. In such a manner, different regions of the end face of the end face connector may be distinguishable and may allow identification and/or verification of the end face and further, the tube being used. For example, the end face connector may include a marking, such as a line, at the circumference of the device end of the connector. Likewise, the connector device may include a marking, such as a line, at the circumference of the device connector. After (or during)

attaching the connectors, the two markings on the two connectors must be aligned. Alignment of the markings on the connectors ensures proper relative alignment of the end face of the connector with the corresponding receivers/detectors of the verification system of the medical device. In such a manner, different regions of the end face of the connector may be distinguishable and may allow identification and/or verification of the end face and hence the tube being used.

According to some embodiments, the threshold values may be chosen to be such that would discriminate between integrated voltage values that result from the reflection of light from various regions of the end face of the connector and other sources of light. The threshold values may further be used to discriminate between various types of connectors, such as, for example, between connectors that may have only one reflective region on the end face and connectors that may have more than one reflective region on their end face. In addition, the threshold values may be used to discriminate between connectors that have one or more reflective regions on their end face and connectors that have no reflective regions on their end face. In addition, the threshold values may be used to discriminate between various types, classes and/or models of connectors, that may be adapted for various uses (for example, use with children sampling lines, adults sampling lines, and the like).

According to some embodiments, the end face of the connector may include an additional distinguishing feature in addition to being reflective. For example, the additional feature may include radioactive labeling of at least a distinct region of the end face. The radioactive labeling may include spots deposited along the annular circumference of the end face of the connector. The radioactive spots may include radioactive labeling using any common radioisotope, such as, for example, deuterium (H^3), C^{14} , P^{32} , S^{35} and the like. In addition, the medical device verification system may include an appropriate matching radioactive detector, such as a radioactive counter that may be used to detect radioactive energy emitted from the connector end face.

According to some embodiments, the end face of the connector may include an additional distinguishing feature in addition to being reflective. For example, the end face of the connector may include an electronic identification means, such as, for

example, a Radio Frequency Identification (RFID). RFID is known as an automatic identification method, that stores and remotely retrieves data using RFID tags or transponders. An RFID tag is an identification tag that may be identified wirelessly using radio waves. Most RFID tags include at least two parts: an integrated circuit for storing and processing information, modulating and demodulating a radio frequency signal; and an antenna for receiving and transmitting the signal. In addition, a technology called chipless RFID allows for discrete identification of tags without an integrated circuit. According to some embodiments, an RFID tag may be implemented with the connector. The RFID tag may preferably be implemented at the end face of the connector, for example, by using a chipless RFID that may be printed on at least a region of the end face of the connector. The RFID tag may be of the passive type, which is a tag that does not need an autonomous power supply. The RFID tag may include specific information characteristic of the connector, such as type, class and model of the connector. In addition, the verification system of the medical device may include an antenna and an RFID reader that may identify the RFID tag and read/process the information encoded within the RFID tag. For example, the RFID tag may include information regarding the type, class and model of the connector (for example, for what type of patient it is to be used with: a child or an adult; intubated patient or non-intubated patient; who is the manufacturer that produced the connector, and the like).

According to some embodiments, the end face of the connector may include an additional distinguishing feature in addition to being reflective. For example, the end face of the connector may include a barcode pattern that may be present on at least one region of the end face of the connector. The barcode may be used to identify the connector type/model to the medical device to which it is to be connected. In addition, the medical device verification system may further include an appropriate barcode reader, such as, for example, a barcode scanner, that may be used to detect the presence of a barcode on the end face and to further interpret the barcode. The barcode may be read "on the fly", while the connector is being turned/screwed into its location towards its final position. Identification of the barcode by the medical device verification system may allow proper identification of the connector that is connected to the medical device and accordingly, adjust the operation mode of the medical device.

According to some embodiments, the end face of the connector may include an additional distinguishing feature in addition to being reflective. For example, the end face of the connector may include one or more regions that include distinct magnetic field characteristics. The one or more regions with the distinct magnetic properties may be of any shape and size. The distinct magnetic properties may be achieved by, for example, using a coating, which has magnetic properties, that may be applied to the appropriate region on the end face. In addition, the medical device verification system may further include an appropriate magnetic field detector, that may be used to detect the presence and/or force of the magnetic field created by the one or more regions of the end face.

According to some embodiments, the end face of the connector may include an additional distinguishing feature in addition to being reflective. For example, the end face of the connector may include one or more regions that include distinct electrical field characteristics. The one or more regions with the distinct electrical properties may be of any shape and size. The distinct electrical properties may include, for example, regions with different electrical conductance, different electrical field, different electrical energy produced thereby, and the like. The distinct electrical properties may be applied by, for example, applying small electrical power to specified one or more regions on the end face. In addition, the medical device verification system may further include an appropriate electrical detector, that may be used to detect the presence and/or force of the electrical energy and/or current and/or conductance and/or electrical field created by the one or more regions of the end face with distinct electrical properties.

According to some embodiments, the end face of the connector may include an additional distinguishing feature in addition to being reflective. For example, the use of pressure drop detection across the sampling line used may also be used as a verification method to determine if the connector is of the appropriate class, type, an/or model. Detection of pressure drop may be performed, for example, initiating operation of the medical device upon first verification of correct attachment between the connector and the medical device. Then, different pressure drops across the sampling line are created and detected. The different pressure drops, which are

characteristics of a sampling line, may be detected and may thus identify the sampling line used with the attached connector. If the pressure drop identifies a connector/sampling line that is not of the required/desired type (such as, for example, not by the desired manufacturer), the operation of the medical device may stop until a proper connector and sampling line are attached to the device.

According to further embodiments, the end face of the connector may include one or more light sources. The light sources may include, for example, one or more LED that may emit light at various, distinct wavelengths. The one or more LED may receive power from an internal power supply, such as, for example, small batteries located within the cavity of the connector. The LEDs may emit light at predetermined wavelength ranges that may match corresponding light detectors, such as, for example, photodiodes, located in the verification system of the medical device. The light detectors may convert the detected light to a binary signal, as detailed above herein to determine the type, class and/or model, of the connector and to determine the correct assembly of the connector to the medical device. If the connector is properly attached to the medical device and is of the appropriate type, the device may operate in an operation mode that is suitable for the detected connector.

While a number of exemplary aspects and embodiments have been discussed above, those of skill in the art will recognize certain modifications, permutations, additions and sub-combinations thereof. It is therefore intended that the following appended claims and claims hereafter introduced be interpreted to include all such modifications, permutations, additions and sub-combinations as are within their true spirit and scope.

CLAIMS

What we claim is:

5

1. A tube connector for connecting between a fluid sampling tube and a fluid analyzer, the tube connector comprising:
an end face adapted to identify the tube connector, said end face comprising a reflecting surface having one or more reflective regions adapted to reflect
10 light at a predetermined range of wavelengths.

2. The tube connector of claim 1, wherein said surface is adapted to reflect light at one or more distinct wavelengths.

3. The tube connector of claim 1, wherein said surface is adapted to selectively reflect light having different intensities.

15

4. The tube connector of claim 1, wherein said surface comprises one or more reflective regions having distinct reflective properties.

5. The tube connector of claim 1, wherein said surface is patterned.

6. The tube connector of claim 5, wherein said pattern includes geometrical shapes, non geometrical shapes, horizontal lines, vertical lines or any
20 combination thereof.

7. The tube connector of claim 1, wherein the fluid analyzer comprises a capnograph.

8. The tube connector of claim 1, wherein the fluid analyzer comprises a verification system adapted to identify the connector.

25

9. The tube connector of claim 8, wherein said verification system comprises one or more light sources and one or more optical detectors.

10. The tube connector of claim 9, wherein said one or more optical detector comprises an RGB detector.

30

11. The tube connector of claim 10, wherein said one or more light sources comprise a light emitting diode (LED), a lamp or any combination thereof.

12. The tube connector of claim 1, wherein said end face comprises a Radio Frequency Identifier (RFID) tag adapted to provide further identification of the connector type.

13. The tube connector of claim 1, wherein said end face further comprises a barcode tag adapted to provide further identification of the connector type.
14. The tube connector of claim 8, wherein the verification system comprises a Radio Frequency Identifier (RFID) reader, a barcode scanner or both.
- 5 15. A device for analyzing fluid, said device comprising:
a device connector adapted to receive a tube connector; and
a verification system for identifying the tube connector, wherein said system comprises one or more light sources adapted to transmit light towards an end face of the tube connector, one or more optical detectors adapted to
10 detect reflected light from the end face and to produce a signal indicative of the reflected light and a processor adapted to identify the tube connector type based on a signal received from the detector.
16. The device of claim 15, wherein said tube connector is adapted to connect between a fluid sampling tube and said fluid analyzer.
- 15 17. The device of claim 15, wherein said end face comprises a reflecting surface having one or more reflective regions adapted to reflect light at a predetermined range of wavelengths.
18. The device of claim 17, wherein said surface is adapted to reflect light at one or more distinct wavelengths.
- 20 19. The device of claim 17, wherein said surface is adapted to selectively reflect light having different intensities.
20. The device of claim 17, wherein said surface comprises one or more reflective regions having distinct reflective properties.
21. The device of claim 17, wherein said surface is patterned.
- 25 22. The device of claim 21, wherein said pattern includes geometrical shapes, non-geometrical shapes, horizontal lines, vertical lines or any combination thereof.
23. The device of claim 15, comprising a capnograph.
24. The device of claim 15, wherein said one or more optical detectors
30 comprises an RGB detector.
25. The device of claim 15, wherein said one or more light sources comprise a light emitting diode (LED), a lamp or any combination thereof.

26. The device of claim 15, wherein said end face comprises a Radio Frequency Identifier (RFID) tag adapted to provide further identification of the connector.
27. The device of claim 15, wherein said end face further comprises a barcode tag adapted to provide further identification of the connector.
28. The device of claim 23, wherein said verification system further comprises a Radio Frequency Identifier (RFID) reader, a barcode scanner or both.
29. A verification system for identifying a tube connector attached to a fluid analyzer, the system comprising:
- one or more light sources adapted to transmit light towards an end face of the tube connector;
- one or more optical detectors adapted to detect reflected light from the end face and to produce a signal indicative of the reflected light; and
- a processor adapted to identify the tube connector type based on a signal received from the detector.
30. The verification system of claim 29, wherein said system is functionally associated with a device connector adapted to receive the tube connector.
31. The verification system of claim 29, wherein said end face comprises a reflecting surface having one or more reflective regions adapted to reflect light at a predetermined range of wavelengths.
32. The verification system of claim 31, wherein said surface is adapted to reflect light at one or more distinct wavelengths.
33. The verification system of claim 31, wherein said surface is adapted to selectively reflect light having different intensities.
34. The verification system of claim 31, wherein said surface comprises one or more reflective regions having distinct reflective properties.
35. The verification system of claim 31, wherein said surface is patterned.
36. The verification system of claim 35, wherein said pattern includes geometrical shapes, non-geometrical shapes, horizontal lines, vertical lines or any combination thereof.
37. The verification system of claim 29, wherein said fluid analyzer comprises a capnograph.
38. The verification system of claim 29, wherein said one or more optical detectors comprises an RGB detector.

39. The verification system of claim 29, wherein said one or more light sources comprise a light emitting diode (LED), a lamp or any combination thereof.
40. The verification system of claim 29, wherein said end face further comprises a Radio Frequency Identifier (RFID) tag adapted to provide further
5 identification of the connector.
41. The verification system of claim 29, wherein said end face further comprises a barcode tag adapted to provide further identification of the connector.
42. The verification system of claim 29, further comprising a Radio Frequency Identifier (RFID) reader, a barcode scanner or both.
- 10 43. The verification system of claim 29, wherein said system is adapted to trigger activation or choosing mode of operation of the fluid analyzer if the identification of the tube connector matches a predetermined parameter.
44. The verification system of claim 43, wherein said parameter comprises wavelength, intensity, radio frequency identifier (RFID) signal, barcode
15 pattern, or any combination thereof.
45. A method for identifying a tube connector type attached to a fluid analyzer, the method comprising:
transmitting light from one or more light sources towards an end face of the
tube connector;
20 detecting reflected light from the end face by one or more optical detectors;
producing a signal indicative of the reflected light; and
identifying the tube connector based on the signal.
46. The method of claim 45, wherein said tube connector is adapted to connect between a fluid sampling tube and said fluid analyzer.
- 25 47. The method of claim 45, wherein said end face comprises a reflecting surface having one or more reflective regions adapted to reflect light at a predetermined range of wavelengths.
48. The method of claim 47, wherein said surface is adapted to reflect light at one or more distinct wavelengths.
- 30 49. The method of claim 47, wherein said surface is adapted to selectively reflect light having different intensities.
50. The method of claim 47, wherein said surface comprises one or more reflective regions having distinct reflective properties.
51. The method of claim 47, wherein said surface is patterned.

52. The method of claim 51, wherein said patterned includes geometrical shapes, non-geometrical shapes, horizontal lines, vertical lines or any combination thereof.
53. The method of claim 45, wherein said end face further comprises a Radio Frequency Identifier (RFID) tag adapted to provide further identification of the connector.
54. The method of claim 45, wherein said end face further comprises a barcode tag adapted to provide further identification of the connector.
55. The method of claim 45, wherein said fluid analyzer comprises a capnograph.
56. The method of claim 45, wherein said one or more light sources comprise a light emitting diode (LED), a lamp or any combination thereof.
57. The method of claim 45, wherein said one or more light detectors comprise an RGB detector.
58. The method of claim 45 further comprising identifying a radio frequency identifier (RFID) signal, a barcode pattern, or any combination thereof.
59. The method of claim 45 wherein said signal comprises wavelength, intensity, radio frequency identifier (RFID) signal, barcode pattern, or any combination thereof.
60. The method of claim 45 further comprising triggering activation of the fluid analyzer if the identification of the tube connector matches a predetermined parameter.
61. The method of claim 60, wherein said predetermined parameter comprises wavelength, intensity, radio frequency identifier (RFID) signal, barcode pattern, or any combination thereof.

1/3

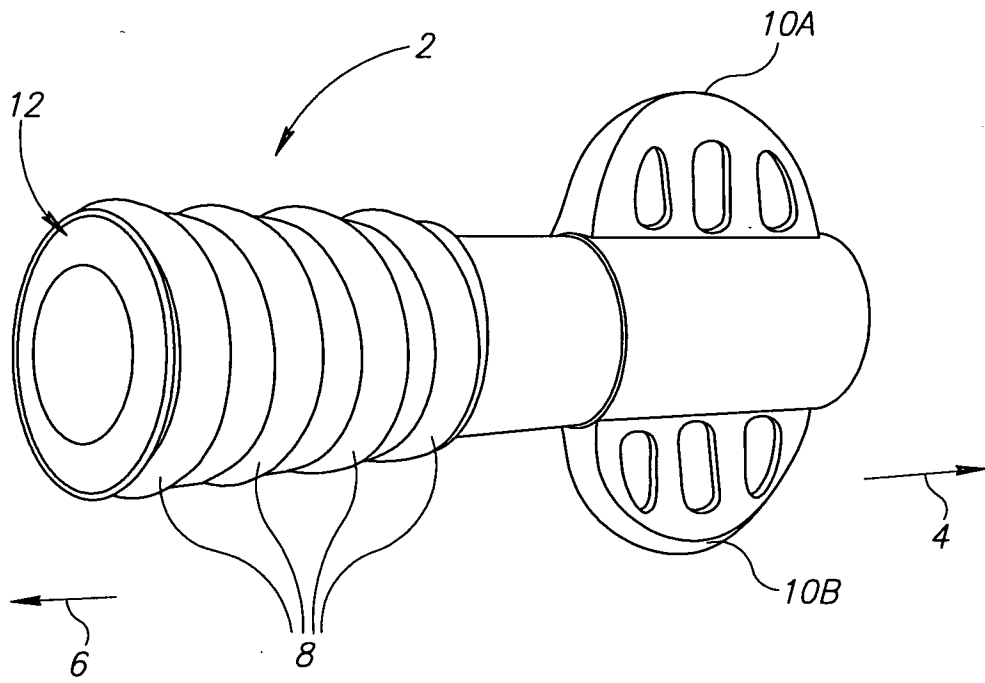

FIG.1

2/3

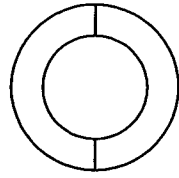

FIG. 2A

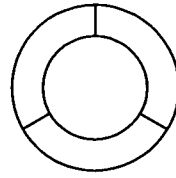

FIG. 2B

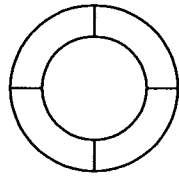

FIG. 2C

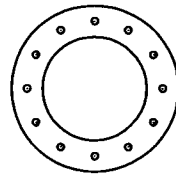

FIG. 2D

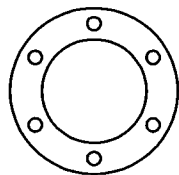

FIG. 2E

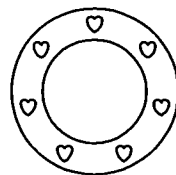

FIG. 2F

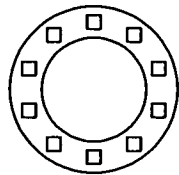

FIG. 2G

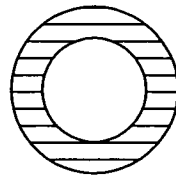

FIG. 2H

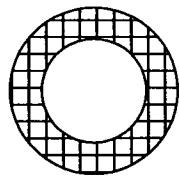

FIG. 2I

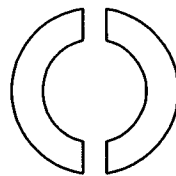

FIG. 2J

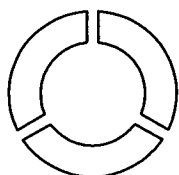

FIG. 2K

3/3

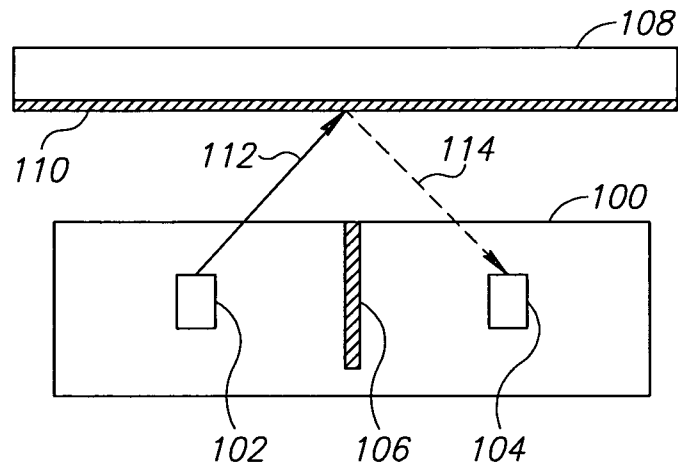

FIG. 3A

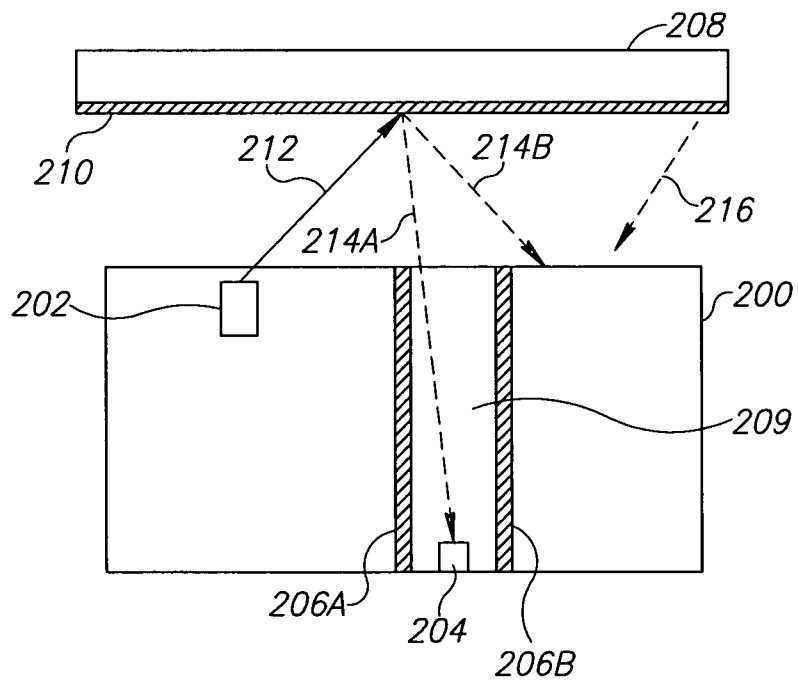

FIG. 3B

INTERNATIONAL SEARCH REPORT

International application No
PCT/IL2007/001632A. CLASSIFICATION OF SUBJECT MATTER
INV. G01N35/00 A61M39/10

According to International Patent Classification (IPC) or to both national classification and IPC

B. FIELDS SEARCHED

Minimum documentation searched (classification system followed by classification symbols)

G01N A61M B01L A61B H01R

Documentation searched other than minimum documentation to the extent that such documents are included in the fields searched

Electronic data base consulted during the international search (name of data base and, where practical, search terms used)

EPO-Internal

C. DOCUMENTS CONSIDERED TO BE RELEVANT

Category*	Citation of document, with indication, where appropriate, of the relevant passages	Relevant to claim No.
X	US 6 437 316 B1 (COLMAN JOSHUA L [IL] ET AL) 20 August 2002 (2002-08-20) cited in the application column 4, line 1 - column 6, line 67; figures 1-4	1-61
X	US 2005/273016 A1 (COLMAN LEWIS [IL] ET AL) 8 December 2005 (2005-12-08) paragraph [0076]; figure 2	1, 15, 29, 45
A	US 6 468 424 B1 (DOENIG RAINER [DE] ET AL) 22 October 2002 (2002-10-22) column 4, line 25 - column 6, line 2; figures 1,2	12-14, 26-28, 40-44, 53, 54, 58-61

 Further documents are listed in the continuation of Box C. See patent family annex.

* Special categories of cited documents:

- *A* document defining the general state of the art which is not considered to be of particular relevance
- *E* earlier document but published on or after the international filing date
- *L* document which may throw doubts on priority claim(s) or which is cited to establish the publication date of another citation or other special reason (as specified)
- *O* document referring to an oral disclosure, use, exhibition or other means
- *P* document published prior to the international filing date but later than the priority date claimed

- *T* later document published after the international filing date or priority date and not in conflict with the application but cited to understand the principle or theory underlying the invention
- *X* document of particular relevance; the claimed invention cannot be considered novel or cannot be considered to involve an inventive step when the document is taken alone
- *Y* document of particular relevance; the claimed invention cannot be considered to involve an inventive step when the document is combined with one or more other such documents; such combination being obvious to a person skilled in the art.
- *8* document member of the same patent family

Date of the actual completion of the international search

26 August 2008

Date of mailing of the international search report

04/09/2008

Name and mailing address of the ISA/

European Patent Office, P.B. 5818 Patentlaan 2
NL - 2280 HV Rijswijk
Tel. (+31-70) 340-2040, Tx. 31 651 epo nl,
Fax: (+31-70) 340-3016

Authorized officer

Cantalapiedra, Igor

INTERNATIONAL SEARCH REPORT

International application No

PCT/IL2007/001632

C(Continuation). DOCUMENTS CONSIDERED TO BE RELEVANT

Category*	Citation of document, with indication, where appropriate, of the relevant passages	Relevant to claim No.
X	WO 01/75439 A (ORIDION MEDICAL 1987 LTD [IL]; BEN OREN ILAN [IL]; CARLEBACH EPHRAIM [] 11 October 2001 (2001-10-11) page 44, line 1 - page 46, line 3 -----	1, 15, 29, 45
A	US 6 325 422 B1 (VERKAART WESLEY H [US] ET AL) 4 December 2001 (2001-12-04) column 2, line 53 - column 3, line 4 column 4, lines 10-25 -----	1, 15, 29, 45
A	US 2005/277873 A1 (STEWART JANICE [US] ET AL) 15 December 2005 (2005-12-15) the whole document -----	1-61
A	WO 2004/097994 A (UNIV SHEFFIELD HALLAM [GB]; CHAMBERLAIN PAUL [GB]; WALTERS PETER [GB]) 11 November 2004 (2004-11-11) page 18, lines 11-29; figures 1-6 -----	1
A	WO 2006/070366 A (ORIDION MEDICAL 1987 LTD [IL]; COLMAN JOSHUA LEWIS [IL]; LEVITSKY GERS) 6 July 2006 (2006-07-06) page 5, lines 25-28; figure 1 -----	7, 46
A	US 4 816 418 A (MACK DANIEL R. [US] ET AL) 28 March 1989 (1989-03-28) column 11, line 39 - column 12, line 17; figure 12 -----	1
A	US 6 489 169 B1 (COHEN BERI [US] ET AL) 3 December 2002 (2002-12-03) column 5, lines 41-67 -----	1, 15, 29, 45
A	US 2002/017602 A1 (GSELLER ROLF [DE]) 14 February 2002 (2002-02-14) the whole document -----	1

INTERNATIONAL SEARCH REPORT

Information on patent family members

International application No

PCT/IL2007/001632

Patent document cited in search report	Publication date	Patent family member(s)	Publication date
US 6437316	B1	20-08-2002	CA 2217989 A1 04-05-1998
			DE 69735288 T2 19-10-2006
			EP 0839551 A2 06-05-1998
			IL 119562 A 10-12-2003
			JP 10232190 A 02-09-1998
US 2005273016	A1	08-12-2005	AU 5243100 A 28-12-2000
			EP 1198198 A2 24-04-2002
			WO 0074553 A2 14-12-2000
			JP 2003524149 T 12-08-2003
			US 6969357 B1 29-11-2005
US 6468424	B1	22-10-2002	DE 19814687 C1 18-02-1999
			EP 0947206 A2 06-10-1999
			ES 2284222 T3 01-11-2007
			JP 4108864 B2 25-06-2008
			JP 11319075 A 24-11-1999
WO 0175439	A	11-10-2001	AU 4679801 A 15-10-2001
			EP 1282814 A2 12-02-2003
			JP 2003529766 T 07-10-2003
US 6325422	B1	04-12-2001	US 2002030002 A1 14-03-2002
US 2005277873	A1	15-12-2005	AU 2005249903 A1 15-12-2005
			BR PI0511607 A 02-01-2008
			CA 2560986 A1 15-12-2005
			CN 1942209 A 04-04-2007
			EP 1765434 A1 28-03-2007
			JP 2008500099 T 10-01-2008
			WO 2005118027 A1 15-12-2005
WO 2004097994	A	11-11-2004	GB 2420918 A 07-06-2006
WO 2006070366	A	06-07-2006	EP 1845841 A2 24-10-2007
US 4816418	A	28-03-1989	NONE
US 6489169	B1	03-12-2002	AT 343138 T 15-11-2006
			AU 3905899 A 10-02-2000
			BR 9904604 A 09-01-2001
			CA 2275036 A1 14-01-2000
			DE 69933625 T2 23-08-2007
			DK 0979999 T3 12-02-2007
			EP 0979999 A2 16-02-2000
			ES 2275323 T3 01-06-2007
			JP 2000131329 A 12-05-2000
			NO 993159 A 17-01-2000
			US 6331437 B1 18-12-2001
			US 6444472 B1 03-09-2002
			US 6451259 B1 17-09-2002
			US 6426043 B1 30-07-2002
			US 6426228 B1 30-07-2002
			US 6440368 B1 27-08-2002
US 6426044 B1 30-07-2002			
US 2002017602	A1	14-02-2002	EP 1152244 A2 07-11-2001