

(No Model.)

2 Sheets—Sheet 1.

L. SHOWALTER. CAR COUPLING.

No. 525,802.

Patented Sept. 11, 1894.

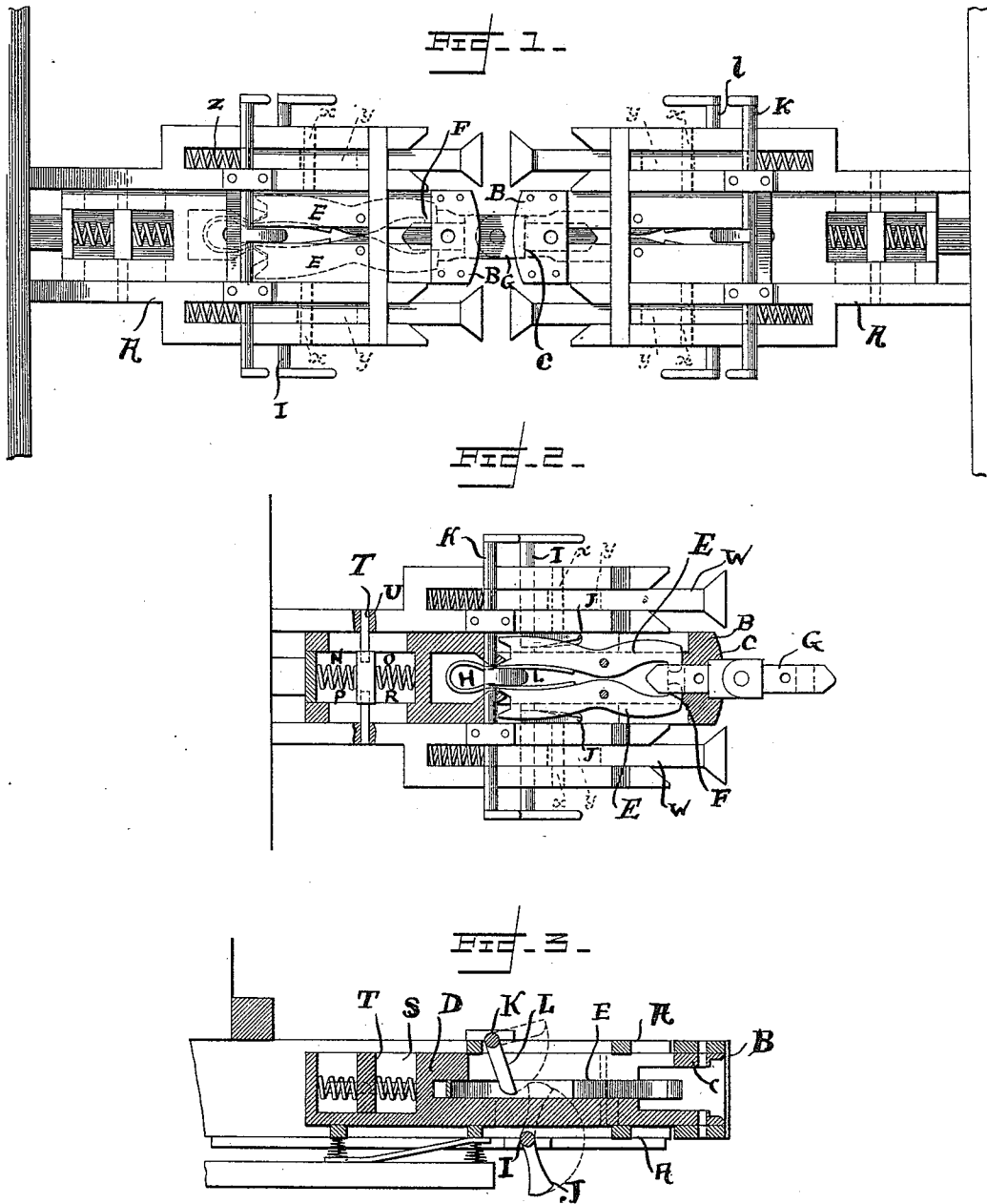

Witnesses
Edw. S. Duvall, Jr.
Joseph H. Hamlen.

Levi Showalter Inventor
by
Goodman & Co. Attorney

(No Model.)

2 Sheets—Sheet 2.

L. SHOWALTER.
CAR COUPLING.

No. 525,802.

Patented Sept. 11, 1894.

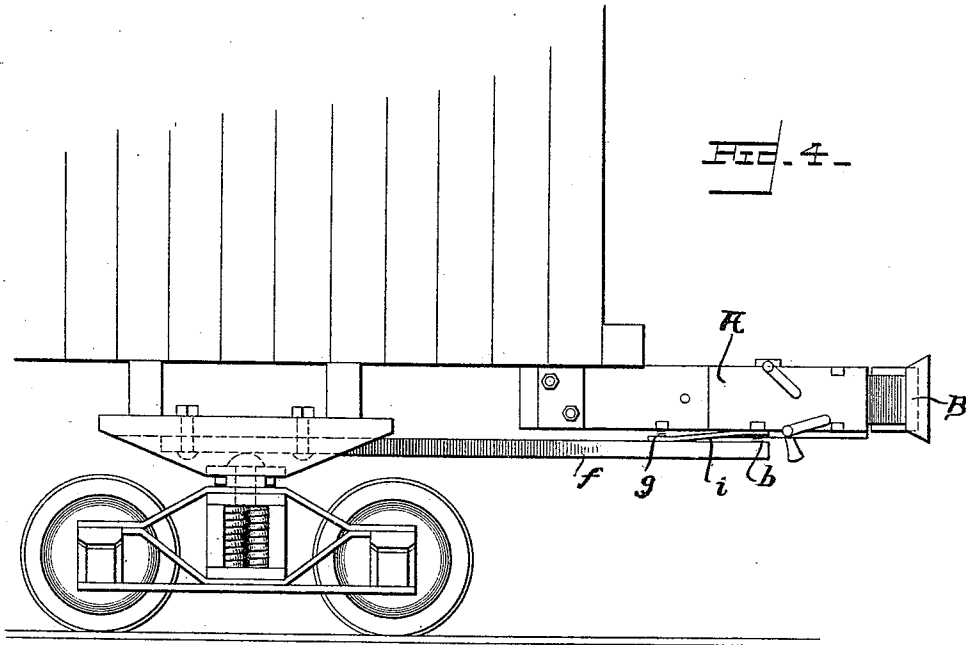
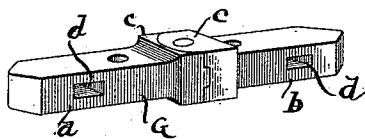

FIG. 5.



Witnesses
Edw. S. Duvall, Jr.
Joseph H. Hamner.

Levi Showalter Inventor
by
J. C. Showalter
Attorney

UNITED STATES PATENT OFFICE.

LEVI SHOWALTER, OF BEETOWN, WISCONSIN.

CAR-COUPLING.

SPECIFICATION forming part of Letters Patent No. 525,802, dated September 11, 1894.

Application filed October 19, 1893. Serial No. 488,614. (No model.)

To all whom it may concern:

Be it known that I, LEVI SHOWALTER, a citizen of the United States, residing at Beetown, in the county of Grant and State of Wisconsin, have invented certain new and useful Improvements in Car-Couplers; and I do hereby declare the following to be a full, clear, and exact description of the invention, such as will enable others skilled in the art to which it appertains to make and use the same.

My invention relates to car couplers and appurtenances thereto, and it has for its object to provide devices of such nature as will automatically couple two cars when brought into sufficiently close relation to cause the link located in one draw-head to be pushed within the opposing draw-head.

A second object of my invention is to provide a connecting link of such form and arrangement of parts as will hold the opposing draw-heads in such close juxtaposition as will prevent the side swing thereof and the resultant disagreeable wobble of the coaches.

A third object of my invention is to provide a draw-bar of such construction as will prevent the jolting of the coaches when the train is either coupled or suddenly started or stopped.

A fourth object which I desire to attain, is to provide auxiliary bumpers adjacent to the draw-head to ease the strain on the connecting link. And a fifth object is to provide a support for the draw-bar and head in order that the distance from the track to the draw-head may be constant.

With these objects in view my invention is constructed and arranged as follows:

Referring to the drawings forming a part of this specification:—Figure 1— is a plan view of two connected opposing connected draw-heads, their buffers and operating mechanisms. Fig. 2— is a plan view of the interior of a draw-head, and showing the mechanism therein. Fig. 3— is a section on line $x-x$ of Fig. 2, the link being removed. Fig. 4— is a view showing the location and arrangement of my improved coupler on a car, and the supporting mechanism therefor; and Fig. 5— is a perspective view of my improved link.

I first provide a suitable casing A, having a trough for the reception of the draw-bar, which will be hereinafter more fully de-

scribed, said draw-bar being connected directly with the draw-head B, and arranged in conjunction therewith to have a sliding motion in the said trough.

As will be seen by reference to the drawings, the interior of the draw-head is provided with an internal narrowed portion of constant diameter forming a shoulder C, for a purpose as will be presently set forth.

The rear portion of the draw-head is provided with a horizontal slot, as shown, extending for a portion of its length and entirely therethrough in a lateral direction. Within this slot are pivoted at points substantially midway of their length, levers E, substantially as shown in the drawings, the front end of such levers forming jaws F to grasp a link G when passed therebetween. The levers are so arranged as that when their rear ends are compressed, the jaws will be forced apart, there being a suitable spring H so arranged as to hold the jaws normally in a closed position.

At a point, preferably in line with the rear ends of the levers, there is passed through the casing, on the lower side thereof and in a lateral direction, a rock-shaft I, having fingers J rigidly secured thereto and arranged to be rocked into suitable vertical slots in the casing and to bear against the exterior sides of the rear ends of the levers E in such a manner as that when the fingers are moved in a rearwardly direction they will compress the said ends of the levers and the jaws will be opened, thus permitting the withdrawal of the link. The rock shaft may be extended to protrude from the side of the car to enable it to be operated by hand without danger to the operator. Diametrically above the aforesaid rock-shaft is located a second similar shaft K, of the same length and provided with a single finger L, to be turned through a suitable vertical slot into a position between the rear ends of the levers E, in order to prevent their accidental compression, which would result in the opening of the jaws and in some instances allow the uncoupling of the train at a time when accident would be incident thereto.

The draw-bar is made continuous with the draw-head and consists of an oblong box S, having a horizontal slot U formed in its sides,

through which is passed a pin T. The slot U is of sufficient length to allow the pin T to play therein. Interposed between the ends of the said end of the said box S and the pin T is a helical or other suitable spring P, R, to absorb the vibrations due to sudden pulling or of pressing against the draw-head and bar, and causing them to move in their casing.

The draw-head and draw-bar being formed entirely independent of the casing A, it is only necessary that the pin be withdrawn from its slot to enable the entire mechanism to be withdrawn for repairs or other purposes.

The auxiliary bumpers W are each arranged in a close fitting portion of the casing A and are each provided with a horizontal slot *y*, in which plays a removable pin *x* passed through the casing in the manner above described with reference to the draw-bar. At the rear end of the bumper is arranged a spring *z* to press it outwardly and to absorb the vibration thereof.

The link which I prefer to use with my coupler, and which forms an important part of my invention, is as follows:—The link is formed in two parts, *a* and *b*, each having a narrowed end and of constant diameter of such shape as to fit snugly into the draw-head, the shoulders *c* formed by the said narrowed portion bearing against the internal shoulders C of the draw-head. The two sections of the link are joined together by a hinge so arranged as to allow a horizontal movement of the parts thereof, thereby enabling a train to be run round a curve in the track. The auxiliary bumpers hereinbefore mentioned are always in contact with the similar bumpers on the contiguous car, whereby the strain on the link is eased to a great extent. The tapered extremities of the link are provided with horizontal indentations *d* to receive the projections *e* of the coupler jaws.

In addition to the above-named elements I have provided a novel support for the draw-bar, the object of which is to support the said bar and its head at a constant elevation above the track. This may consist of a beam, *f*, as shown in Fig. 4, provided at each end with a spiral or helical spring *g* and *h* and a metal or other strip *i*, having one end attached to the beam at a point directly in the rear of one of said springs *g* and extending to lie upon the other spring *h*, whereby a bearing surface will be provided for the draw-

bar, which is arranged to lie thereupon, and wear due to contact with the spring will be prevented. The rear end of the beam *l* is secured to the timbers just above the truck, and is intended to be used upon such cars in which the springs are placed between such timbers and the body of the car. It will thus be seen that the draw-head will be held at a constant elevation above the track.

Having thus fully described my invention, what I claim as new, and desire to secure by Letters Patent, is—

1. A car coupler consisting of a casing, a draw-bar and draw-head therein, jaws inclosed within the bar and head for the reception and retention of a connecting device, means for opening the jaws, and a rock-shaft provided with a finger for locking the jaws in a closed position.

2. A car coupler consisting of a casing, a draw-bar and draw-head therein, levers pivoted midway of their lengths inclosed within the casing and head, and a rock shaft having fingers arranged to inclose and compress the rear ends of the levers to open and lock the jaws in an open position.

3. A car coupler consisting of a casing, a draw-bar therein, a draw-head therefor, jaws inclosed within the head and bar, and means for locking the jaws in a closed position, as set forth.

4. A coupling link comprising two parts hinged together each part having near its free end oppositely arranged indentations extending in the plane of the swing of the parts, and perforations formed at right angles thereto.

5. A link consisting of two parts hinged together, each part having lateral indentations and a vertical slot, as set forth.

6. A support for draw-heads comprising a beam adapted to rest on the car truck, said beam having helical springs arranged on the upper side thereof to receive pressure of the draw-head and the car body, and a spring metal plate extending from beneath the base of one of said springs to and over the top of the other of said springs, as set forth.

In testimony whereof I affix my signature in presence of two witnesses.

LEVI SHOWALTER.

Witnesses:

JOSEPH H. HANNEN,
F. D. BLACKSTONE.