

H. N. LYON.
AUTOMATIC STOCK OR POULTRY FEEDER.
APPLICATION FILED NOV. 13, 1903.

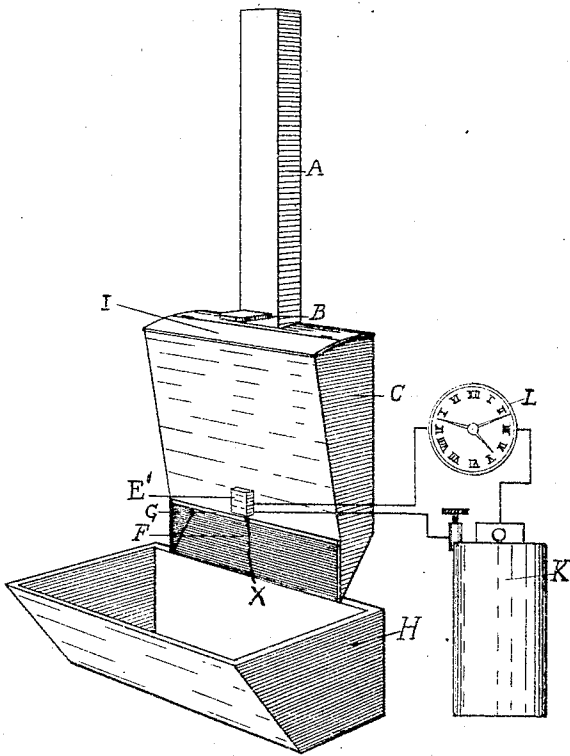

Fig. 1

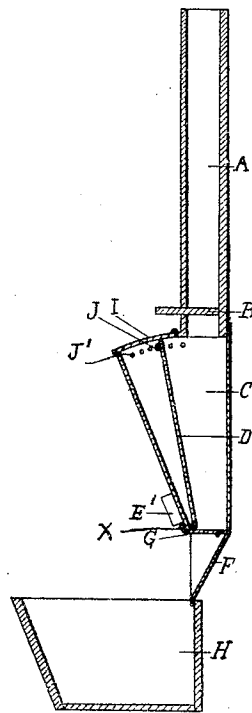

Fig. 2

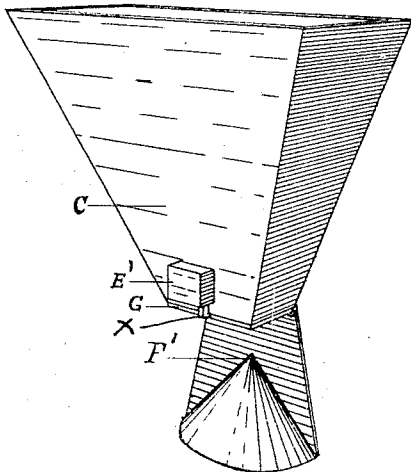

Fig. 3

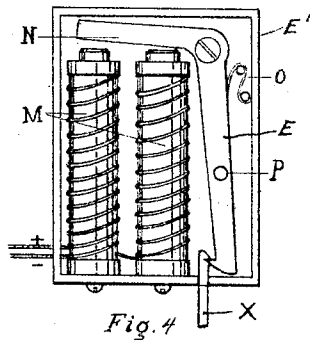

Fig. 4

WITNESSES:

Wm. S. Hodges
Lewis Hodges

INVENTOR
Howard N. Lyon
BY
Henry P. Blair,
ATTORNEY.

UNITED STATES PATENT OFFICE.

HOWARD N. LYON, OF WHEATON, ILLINOIS.

AUTOMATIC STOCK OR POULTRY FEEDER.

SPECIFICATION forming part of Letters Patent No. 779,434, dated January 10, 1905.

Application filed November 13, 1903. Serial No. 181,101.

To all whom it may concern:

Be it known that I, HOWARD N. LYON, of Wheaton, in the county of Dupage and State of Illinois, have invented certain new and useful Improvements in Automatic Stock or Poultry Feeders; and I do hereby declare the following to be a full, clear, and exact description of the invention, such as will enable others skilled in the art to which it appertains to make and use the same.

This invention relates to certain new and useful improvements in automatic stock and poultry feeders.

The invention has for its object the production of simple and inexpensive means whereby stock or poultry may be fed at a predetermined time.

A further object is to provide means whereby the quantity of food so fed may be regulated.

The invention will be hereinafter fully set forth, and particularly pointed out in the claims.

In the accompanying drawings, Figure 1 is a view in perspective illustrating my invention. Fig. 2 is a longitudinal sectional view thereof. Fig. 3 is a perspective view of a slight modification. Fig. 4 is a detail view of the lock.

Referring to the drawings, C designates a hopper which is provided with a hinged cover I and a supply-pipe A, the latter leading from a storage-bin or other source of supply. (Not shown.) Said pipe is provided with a cut-off slide B. The bottom of the hopper C is closed by a hinged door G, the latter being provided with an upwardly-extended lock-arm X, the extremity of which is normally engaged by a locking-latch E, pivotally mounted in a casing E', secured to hopper C. A suitable trough H is located below the hopper C and the latter is provided with an inclined deflector F, which serves to direct the grain toward the center of said trough. The capacity of hopper C is varied by means of a partition D, pivotally mounted at its lower end within said hopper, said partition being held in any adjusted position by means of a bolt J passed through any one of a series of openings J' formed in the hopper casing. By pivoting partition D

at its lower end the same may be adjusted to approximately parallel either the front or the rear wall of the hopper or may be secured at any radial point intermediate of said adjustments. In this manner the capacity of the hopper may be readily varied and at the same time the exit is left perfectly free and uninterrupted by said partition.

The latch E is pivotally mounted in a casing E' and is provided with an angular extension N, forming an armature for the magnet M, located in said casing, and in circuit with a battery K. Said latch is normally held in its locking position by means of a spring O, and, if desired, may also be provided with a pin P, whereby the same may be disengaged from the door G independent of the action of the magnet. A clock L or other suitable timing device may be placed in circuit with battery K and in series with the magnet, whereby the latter will be energized at a predetermined time.

In Fig. 3 I have shown a slight modification of the deflector, the same consisting in forming said deflector of approximate cone shape, whereby the grain is scattered, this form being particularly desirable for feeding poultry.

In practice the partition D is adjusted to regulate the capacity of hopper C as may be desired and the door G locked in its closed position. The cut-off slide B is then withdrawn and the hopper filled, after which said cut-off is returned. The timing device is then set, whereupon when the predetermined time arrives the electric circuit will be closed and magnet M energized. The armature N is thus attracted, whereupon the latch E is disengaged from the door G and the weight of the grain forces the latter open, and as the grain falls the deflector will guide the same into the trough or scatter the same, according to the form of deflector employed.

The advantages of my improved feeder will be apparent to those skilled in the art to which it appertains, and it will be particularly noted that by means of this device the stock or poultry may be regularly fed without the necessity of an attendant being upon the spot. It will also be observed that my improved

feeder is simple and inexpensive in construction and being composed of few parts will not readily get out of order or become deranged. A further advantage lies in the fact that the hopper can be adjusted in capacity to suit the demands of the stock.

I claim as my invention—

1. A device of the character described comprising a hopper having an outlet, a partition or diaphragm independent of the walls of said hopper and pivotally mounted at its lower end within the latter, means for holding the upper end of said partition or diaphragm in any adjusted position, whereby the capacity of said hopper may be varied and an unobstructed discharge maintained, a pivotal door closing said outlet, and means for effecting the automatic opening of said door.

2. A device of the character described comprising a hopper having an outlet, a partition or diaphragm pivotally mounted at its lower end within the latter, means for holding the upper end of said partition or diaphragm in any adjusted position, whereby the capacity of said hopper may be varied and an unobstructed discharge maintained, a pivotal door closing said outlet, means for effecting the automatic opening of said door, and a deflector located below said outlet-opening.

3. A device of the character described comprising a hopper having an outlet and provided with a plurality of perforations, a partition or diaphragm independent of the walls of said hopper and pivotally mounted at its lower end within the latter, a pin adapted to enter any one of said perforations and adapted to engage the free end of said partition, whereby the capacity of said hopper may be varied and an unobstructed discharge maintained, a pivotal door closing said outlet and means for effecting the automatic opening of said door.

4. A device of the character described comprising a hopper, a partition or diaphragm independent of the walls of said hopper and

pivoted adjacent to one of said walls, means for adjusting said partition or diaphragm to approximately parallel the opposite wall of said hopper and to points intermediate of said last-mentioned adjustment, whereby the capacity of said hopper may be varied, and an unobstructed discharge maintained, and means for effecting an automatic discharge of the contents of said hopper.

5. A device of the character described comprising a hopper, a partition or diaphragm independent of the walls of said hopper and pivoted adjacent one of said walls, means for adjusting said partition or diaphragm to approximately parallel the opposite wall of said hopper and to points intermediate of said last-mentioned adjustment, whereby the capacity of said hopper may be varied, and an unobstructed discharge maintained, means for effecting an automatic discharge of the contents of said hopper, and a deflector located below said hopper.

6. A device of the character described comprising a hopper, means for varying the capacity thereof, a pivoted door fitting over the lower end of said hopper and having an upwardly-extending latch-arm, an electromagnet, and a latch adapted to engage said latch-arm, said latch having an angular portion overhanging said magnet and forming an armature therefor.

7. A device of the character described comprising a hopper, a door normally closing the outlet of said hopper, means for automatically releasing said door, and a depending support provided with an approximately cone-shaped deflector located below said door.

In testimony whereof I have signed this specification in the presence of two subscribing witnesses.

HOWARD N. LYON.

Witnesses:

CHARLES E. VRUMAN,
STELLA W. TENNEY.