

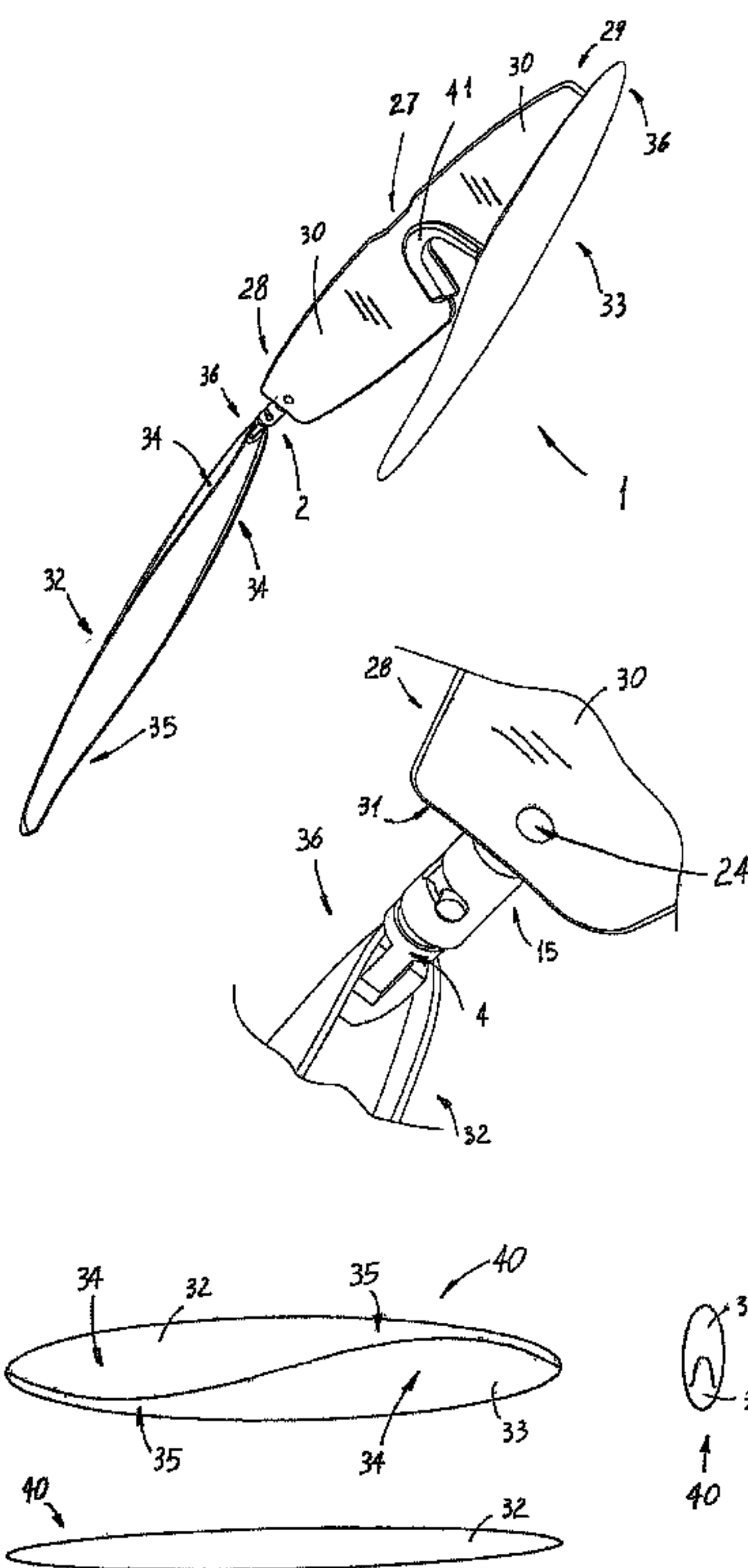

(86) Date de dépôt PCT/PCT Filing Date: 2005/02/16
 (87) Date publication PCT/PCT Publication Date: 2005/09/01
 (85) Entrée phase nationale/National Entry: 2006/08/14
 (86) N° demande PCT/PCT Application No.: IT 2005/000077
 (87) N° publication PCT/PCT Publication No.: 2005/081045
 (30) Priorité/Priority: 2004/02/20 (ITTV2004A000018)

(51) Cl.Int./Int.Cl. *G02C 5/00* (2006.01)
 (71) Demandeur/Applicant:
 FOTO OTTICA CESCO, DI CESCO STEFANO, IT
 (72) Inventeurs/Inventors:
 BREDA, PIERLUIGI, IT;
 MAZZERO, ALESSANDRO, IT
 (74) Agent: MARKS & CLERK

(54) Titre : MONTURE DE LUNETTES EQUIPEE DE BRANCHES POSSEDANT DEUX AXES DE ROTATION
 ORTHOGONAUX FORMANT UN ETUI LORSQU'ELLES SONT REPLIEES
 (54) Title: EYEGGLASS FRAME WITH TEMPLES HAVING TWO ORTHOGONAL AXES OF ROTATION AND FORMING A
 CASE WHEN FOLDED



(57) **Abrégé/Abstract:**
 The invention relates in particular to an eyeglass frame (1) which is distinguished by the fact that it contains a first (32) and second (33) semi-shell shaped earpieces, rotationally linked to a first (2) and second (3) hinge that are linked to a frontal piece (27) and/or at least one lens, the earpieces can close to form a shell to temporarily hold the frontal piece and/or at least one lens.

(12) INTERNATIONAL APPLICATION PUBLISHED UNDER THE PATENT COOPERATION TREATY (PCT)

(19) World Intellectual Property
Organization
International Bureau



(43) International Publication Date
1 September 2005 (01.09.2005)

PCT

(10) International Publication Number
WO 2005/081045 A1

(51) International Patent Classification⁷: **G02C 5/00**

(21) International Application Number:
PCT/IT2005/000077

(22) International Filing Date: 16 February 2005 (16.02.2005)

(25) Filing Language: English

(26) Publication Language: English

(30) Priority Data:
TV2004A000018 20 February 2004 (20.02.2004) IT

(71) Applicants and

(72) Inventors: **BREDA, Pierluigi** [IT/IT]; Via G. Pascoli, 18, I-31053 Pieve di Soligo (IT). **MAZZERO, Alessandro** [IT/IT]; Via VIII Armata, 2, I-31040 Nervesa della Battaglia (IT).

(81) Designated States (*unless otherwise indicated, for every kind of national protection available*): AE, AG, AL, AM,

AT, AU, AZ, BA, BB, BG, BR, BW, BY, BZ, CA, CH, CN, CO, CR, CU, CZ, DE, DK, DM, DZ, EC, EE, EG, ES, FI, GB, GD, GE, GH, GM, HR, HU, ID, IL, IN, IS, JP, KE, KG, KP, KR, KZ, LC, LK, LR, LS, LT, LU, LV, MA, MD, MG, MK, MN, MW, MX, MZ, NA, NI, NO, NZ, OM, PG, PH, PL, PT, RO, RU, SC, SD, SE, SG, SK, SL, SY, TJ, TM, TN, TR, TT, TZ, UA, UG, US, UZ, VC, VN, YU, ZA, ZM, ZW.

(84) Designated States (*unless otherwise indicated, for every kind of regional protection available*): ARIPO (BW, GH, GM, KE, LS, MW, MZ, NA, SD, SL, SZ, TZ, UG, ZM, ZW), Eurasian (AM, AZ, BY, KG, KZ, MD, RU, TJ, TM), European (AT, BE, BG, CH, CY, CZ, DE, DK, EE, ES, FI, FR, GB, GR, HU, IE, IS, IT, LT, LU, MC, NL, PL, PT, RO, SE, SI, SK, TR), OAPI (BF, BJ, CF, CG, CI, CM, GA, GN, GQ, GW, ML, MR, NE, SN, TD, TG).

Published:
— with international search report

[Continued on next page]

(54) Title: EYEGLASS FRAME WITH TEMPLES HAVING TWO ORTHOGONAL AXES OF ROTATION AND FORMING A CASE WHEN FOLDED

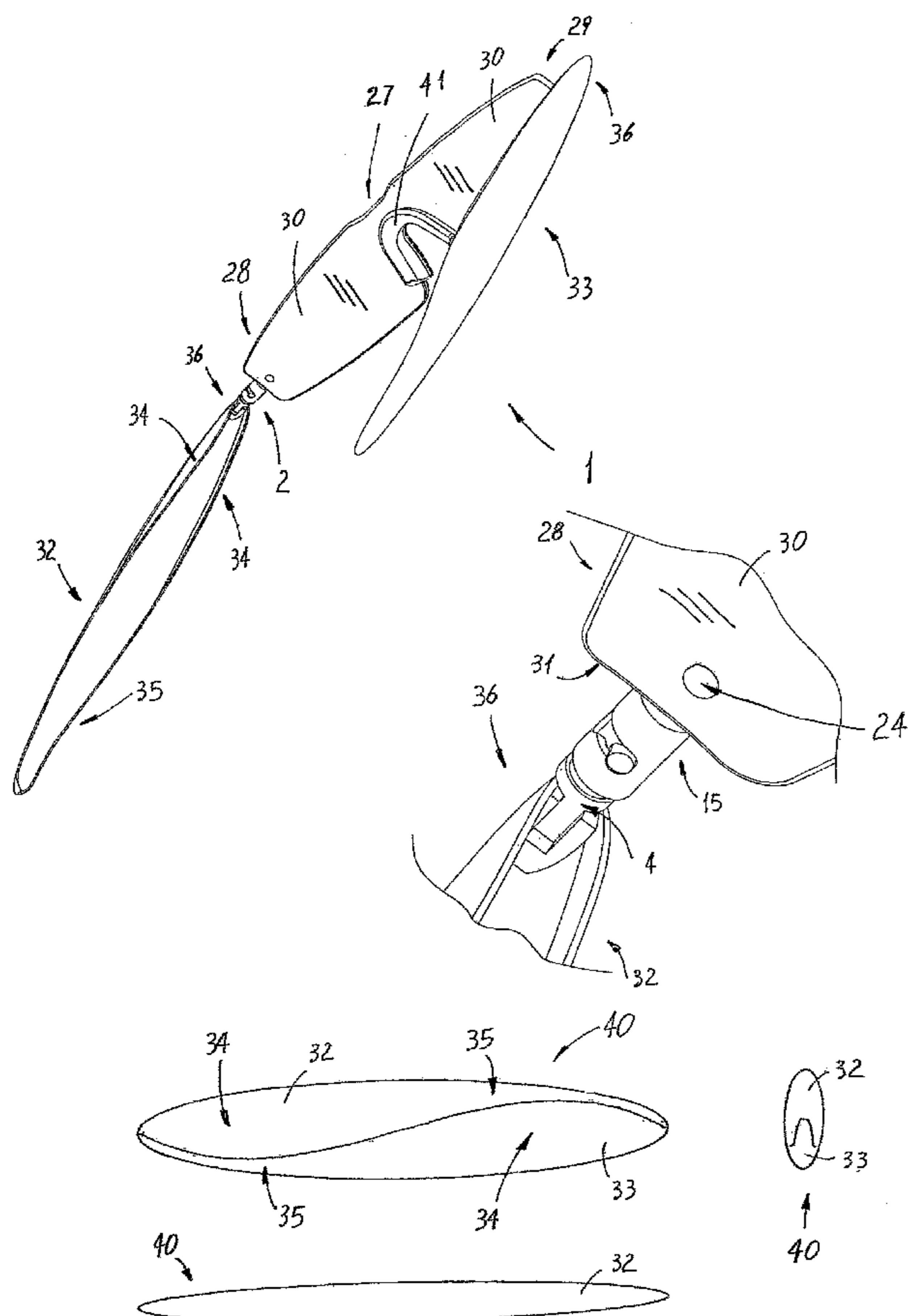

(57) Abstract: The invention relates in particular to an eyeglass frame (1) which is distinguished by the fact that it contains a first (32) and second (33) semi-shell shaped earpieces, rotationally linked to a first (2) and second (3) hinge that are linked to a frontal piece (27) and/or at least one lens, the earpieces can close to form a shell to temporarily hold the frontal piece and/or at least one lens.

WO 2005/081045 A1

WO 2005/081045 A1



For two-letter codes and other abbreviations, refer to the "Guidance Notes on Codes and Abbreviations" appearing at the beginning of each regular issue of the PCT Gazette.

EYEGLASS FRAME WITH TEMPLES HAVING TWO ORTHOGONAL AXES OF
ROTATION AND FORMING A CASE WHEN FOLDED

TECHNICAL FIELD

The invention relates in particular to an eyeglass frame which is
05 distinguished by the fact that it contains a first and second hinge, made
up of a first body, rotationally linked to a semi-shell shaped earpiece and
rotationally interactive, in contrast with an elastically adaptable element,
with a second hollow body linked to a frontal piece and/or at least one
lens, the first and second earpieces can close to form a shell to
10 temporarily hold the frontal piece and/or at least one lens.

BACKGROUND ART

One example of this type of glasses frame exist in the prior art:
EP0723673 which reduces size by rotating the earpieces that are divided
in two segments, one short and one long, but still must be stored in a
15 suitable case after use.

DISCLOSURE OF INVENTION

The subject of this find is an eyeglass frame. The technological
evolution experienced by the eyeglass industry has permitted the market
introduction of products able to offer users increasingly better
20 performance especially in recent years.

Research in this sector has been specifically focused on the
introduction of highly resistant and lightweight materials able to create
extremely compact and lightweight frames in mass produced eyeglasses.

At the same time, the application of new materials and advanced production technologies have led to the development of lenses which, while guaranteeing high corrective strength or improved sun radiation protection, reduce weight and thickness.

05 Thus, more lightweight eyeglasses have been developed whose structural and functional elements, for the most part, contain less resistant sections and are preferably more flexible to better withstand the strain derived from their use, especially when the frames are manipulated to put on or take off the eyeglasses.

10 The main disadvantage of this known type of glasses is the fact that, also due to the abovementioned design objectives, they are particularly fragile when subjected to strains other than those foreseen during use such as, for example, accidental impacts or damages they can incur when not worn by the user or when being stored in their specific
15 and distinct cases.

Furthermore, the lenses placed in the frame, even in the case of sunglasses, can easily be scratched or scuffed by foreign objects, even more easily when the eyeglasses are stored without adequate protection when removed.

20 A partial solution to this problem is the use of special eyeglass cases to be used when not worn by the user for both prescription lenses and sunglasses.

Known eyeglass cases may be hard or soft and are internally lined with very soft material to protect the eyeglasses from strains

that could compromise their integrity and from foreign objects that could scratch the lenses.

05 The main problem of these known cases is the fact that, since separate from the eyeglasses they are designed to hold, they force the user to continually carry them around so that they are available when needed.

10 Since these known cases must be large enough to hold a pair of eyeglasses, although folded, within, they are cumbersome especially when made of a hard structure.

 These known cases can be especially bulky when the user is wearing sunglasses, for example, during a sporting event or sunbathing, situations in which carrying these known cases is extremely awkward.

15 The main purpose of the subject of this find is, therefore, to resolve the indicated technical problems, eliminating the difficulties in the mentioned known technique and therefore to discover a find to create an eyeglass frame that can be quickly stored without requiring external elements to protect it.

20 Within the abovementioned accomplishment, another important purpose is to create a find whose operation is simple and sure.

 Another important purpose is to realize a find with an aesthetically pleasing look in all operating conditions.

Also, and not least important, is to create a find that is structurally simple with limited production costs.

In the construction examples that follow, single features, listed according to specific examples, can actually be exchanged with other different features that exist in other construction examples.

With reference to the figures, number 1 indicates an eyeglass frame comprising a first hinge 2 and a second hinge 3, both the same, each made up of a first body 4 comprising a first joining leg 5, substantially cylindrical in shape from which, near its first flat end 6 a block point 7 radially protrudes, also preferably cylindrical.

At the second end 8 of this first leg 5 is a second block point 9 shown in a side view as a "T" shape defining a cylindrical head with a larger diameter than leg 5 from which a first fin protrudes 10, axial, with a parallelepiped shape.

This first fin 10 is preferably placed in diameter to the first leg 5 of the first body 4, parallel to the axis of the first block point 7 and has a first loop hole 11, cut crosswise and therefore orthogonal to the surface defined by the longitudinal axis of the first leg 5 and axis of the first block point 7.

The free end 12 of this first fin 10 frontally defines a first flat block surface 13, crosswise to the first leg 5 and joined by a curved segment 14 and a second block surface 13a composed of the lateral wall

of the first fin facing the side from which the first block point 7 protrudes and, for example, about orthogonal to this first block surface.

Each of these first and second hinges 2 and 3 are composed of a second body 15, hollow, comprising a second, cylindrical shaped leg 16, inside of which is a first cavity 17, also cylindrical, open at the first end 18 of the second body 15 and coaxial to it.

On the lateral surface of this first cavity 17 is a first circumferential guide 19 composed of a groove 20, straight and looping, that extends for an arch of specific range, for example equal to about 90° , to define, at its opposite ends, a first housing 20a and a second housing 20b.

These first and second housing 20a and 20b, placed respectively rotated by about 90° to the longitudinal axis of the first cavity 17, comprise a protruding curved segment pointing from the first end 18 of the second body 15, from the straight segment that joins them.

Beneficially, this groove 20, in its central straight segment, is slightly wider than the diameter of the first block point 7 to permit it to slide.

The curved segment of the profile of the first and second housings 20a and 20b are also shaped to permit the selective housing of the first block point 7 inside of them.

From the second body 15 protrudes, according to a cord, a second fin 21, it, therefore, protrudes from a second flat end 22 of the second leg 16 and has a circle arch sectional shape that develops along a generatrix.

05 This second fin, 21, has a first flat side 23 that faces the longitudinal axis of the second leg 16 and is preferably parallel to the first housing 20a.

A bearing 24, cylindrical shaped for example, axial to which is a second hole 25, preferably threaded, protrudes orthogonal from the first face 23, pointing in the same direction as the first housing 20a.

10 Lastly, the first and second hinges comprise an elastically adaptable element 26, preferably made up of a cylindrical compression rotor spring that can be housed inside the first cavity 17 of the second body 15 and secured, at one of its first ends, on bottom 17a of the latter.

15 The first cylindrical leg 5, of the first body 4 can therefore be inserted inside this first cavity 17 so that the first block point 7 is housed inside the first guide 19 made up of groove 20 while the first end 6 of this first leg 5 comes into contact with a second end of the elastically adaptable element 26.

20 The first body 4 is therefore rotationally joined to this second body 15 since it can rotate along the longitudinal axis of the first cavity 17 so as to selectively pass from a first position, also called the open position, where the first block point is housed inside the second housing

20a, to a second position, also called the folded position, where this first block point 7 is housed inside the second housing 20b.

05 In these positions, the elastically adaptable element acts against the first end 6 of the first body 4, to force the first block point 7 against the wall of the first or second housing to keep it in the selected position.

10 These first and second hinges, thus assembled, are associated with a frontal piece 27, respectively at a first side end 28, and a second side end 29 of the latter by a bearing 24, each, for example, that can restrain a different lens 30, defined on or supported by this frontal piece by a fastening screw in the thread made inside the second hole 25.

Suitably, the second flat end 22 of the second leg 16 of the second body 15 can act as a block for the side wall 31 of lens 30 preventing any rotation of the first and second hinges 2 and 3 around the bearing 24.

15 In these conditions, the first housing 20a of each hinge faces rear compared to the frontal piece and is about orthogonal to it consequent to the fact that the bearing faces in the same direction of this first housing 20.

20 Beneficially, the shape of the first and second hinges 2 and 3, the same, make sure that the first hinge 2, linked to the frontal piece 27 at its first end 28, presents the second housing 20b facing up while the second hinge 3, linked to the frontal piece 27 at its second end 27 presents the second housing 20b facing down.

05 Connected to frontal piece 27, in its central area, is a removable elastic nose piece 41, made, for example, of rubber or other elastic material, to rest this frontal piece to the user's nose; in this way the nose piece is easily interchangeable if worn or dirty. The frame 1 also comprises a first earpiece 32 and a second earpiece 33, the same, semi-shell shaped.

10 The width of these earpieces is beneficially wider than the thickness of the frontal piece 27 and slightly thinner, at least in their central area, than the thickness of nose piece 41, while their length is slightly longer than the distance between the opposite ends of the first and second hinges protruding laterally from the frontal piece.

15 Each of these first and second earpiece has a front surface 34 with an internal convex profile and rear surface 35 with a concave internal profile, counter-shaped to front surface 34 so that these earpieces, if longitudinally overlapped, reciprocally match to create a housing.

These first and second earpieces 32 and 33 have, at one of their front ends 36, a third housing 37, a third housing 37, open and slightly thicker than the one of the first fin 10 of the first body 7 to permit insertion.

20 This third housing is equipped with a pair of first pins 38, facing each other and protruding from the lower and upper bases of this third housing 37 towards the interior of the latter.

These first pins 38, cylindrical for example, have a diameter slightly smaller than that of the first hole 11 in the first fin 10 so they can be inserted once that latter is housed inside the third housing 37, creating a rotating connection between the first earpiece and the first hinge and
05 between the second earpiece and the second hinge respectively.

The third housing 37 is also equipped with a bottom 39, preferably flat, against which the first block surface 13 can be selectively blocked, frontally defined on each first fin 10 and the second block surface 13a, orthogonal to it.

10 Thanks to the presence of the curved segment 14 which joins these first and second block surfaces, the first and second earpieces can rotate, compared to the first and second hinge respectively, around the first pins 18 so as to move from a first position, where they are orthogonal to the frontal piece 27, to a second position where they are
15 about parallel to the latter.

Frame operations according to the find foresee that, in order to permit user utility, it assumes a shape also called the utility shape, where the first and second earpieces are positioned parallel to each other and protrude to the rear about orthogonal to the frontal piece, as illustrated in
20 figures from 1 to 4.

In this condition, the first block of each hinge is housed inside the first housing 20a, on the second body of each hinge.

Starting from this configuration, the frame can change, by rotating the first body of each hinge around the axis of its relevant second body, to a first intermediate position, illustrated in figure 5, where the first and second

05 earpieces are almost parallel to each other and to the frontal piece, protruding from the latter in opposite directions, one up and the other down.

In fact, during this rotation, the first block 7 of each hinge moves from the first housing 20a to the second housing 20b; thanks to
10 the beneficial location of the first and second hinges, the same, these second housings 20b are one faced up and the other faced down, also forcing these positions on the earpieces that they support respectively.

By rotating each earpiece around the first pins 18, through which they are rotationally linked to the first body of each hinge, the
15 frame can be brought, passing through a second intermediate position, illustrated as an example in figure 8; to a folded position illustrated in figure 9 where these earpieces match longitudinally to create shell 40.

Since the width of these earpieces are greater than the thickness of frontal piece 27 and their length greater than the distance between
20 the opposite ends of the two hinges that laterally protrude from the latter, shell 40 can hold the frontal piece 27 and hinges 2 and 3.

Furthermore, since the width of these earpieces are, at least in their central area, not as thick as the elastic nose piece 41, once moved

to the folded position they slightly deform the latter to guarantee a secure closing of shell 40.

Additionally, the elastic nose piece is a guard for the frontal piece it is linked to.

05 This shell, with opportune resistance and rigidity, is a protection for the eyeglasses and entire frame which therefore does not need to be placed inside a separate case, offering optimal convenience and practicality.

10 If the user wishes to wear the frame, the reverse procedure of the one illustrated above for folding leads to the complete opening of the same and is comfortably wearable.

15 This is proof as to how the find has achieved its set claim and purposes, having discovered an eyeglass frame that permits the creation of is quick housing without requiring the use of external elements for its protection and safeguarding the frontal piece it supports.

Another important purpose achieved by the find is that to guarantee simple and safe operations, while aesthetically pleasing in all operating conditions.

20 Naturally the materials used as well as the sizes of the single find components can be more pertinent according to the specific needs.

The different ways to perform certain different functions should not certainly coexist only in the illustrated creation shape but can be individually present in different creation shapes, even not illustrated.

The aspects indicated as advantageous, opportune or similar can also be missing or replaced by equivalents.

05 Additional aspects and advantages of the find are further emphasized by the detailed description of the special, but not exclusive, creation shape, illustrated in brief but not limited to the enclosed drawing.

BRIEF DESCRIPTION OF DRAWINGS

Figure 1 illustrates, in perspective, the frame according to the find in the use position;

10 figure 2 illustrates, in perspective, a detail of the frame in the use position;

figure 3 illustrates, in perspective, the frame in the use position;

figure 4 illustrates, in perspective, a detail of the frame in the use position;

15 figure 5 illustrates, in perspective, the frame in the first partial fold position;

figure 6 illustrates, in perspective, a detail of the frame in the first partial fold position;

20 figure 7 illustrates a view according to direction VII in figure 5 partially sectioned, a detail of the frame in the first partial fold position;

figure 8 illustrates, from the rear, the frame in the second fold position;

figure 9 illustrates in three views, frontal, side and rear respectively, the frame in the folded position;

figure 10 illustrates, in perspective, a hinge in the open position;

figure 11 illustrates, in enlarged perspective, a hinge;

05 figure 12 illustrates, in two side views, a hinge detail;

figure 13 illustrates, in two side views, a hinge detail;

figure 14 illustrates, in a view used according to the section map

XIV-XIV in figure 13, a hinge detail.

CLAIMS

05 1) Eyeglass frame which is distinguished by the fact that it contains a first and second hinge, made up of a first body, rotationally linked to a semi-shell shaped earpiece and rotationally interactive, in contrast with an elastically adaptable element, with a second hollow body linked to a frontal piece and/or at least one lens, said first and second earpieces can close to form a shell to temporarily hold said frontal piece and/or at least one lens.

10 2) Eyeglass from as per claim 1 which is distinguished by the fact that said first and second hinge are the same and each made up of a first body comprising a first joining leg, substantially cylindrical in shape from which, near its first flat end a block point radially protrudes, preferably cylindrical.

15 3) Eyeglass frame as per claims 1 and 2 which is distinguished by the fact that at the second end of said first leg is a second block presented in a side view in "T" configuration to define a cylindrical heat with a greater diameter than said leg from which a first axial fin protrudes with a parallelepiped surface.

20 4) Eyeglass frame as per claims 1 through 3 that is distinguished by the fact that said first fin is preferably positioning in diameter to said first leg of said first body, parallel to the axis of said first block and has a first loop hole, crosswise on it and therefore orthogonal to a surface

defined by the longitudinal axis of said first leg and the axis of said first block.

05 5) Eyeglass frame as per claims 1 through 4 that is distinguished by the fact that the free end of said first fin frontally defines a first flat block surface, crosswise to said first leg and joined by a curved segment to a second block surface, made up of the lateral wall of said first fin facing from the side from which said first block protrudes, preferably about orthogonal to said first block surface.

10 6) Eyeglass frame as per claims 1 through 5 that is distinguished by the fact that each of said first and second hinges are made up of a second, hollow body equipped with a second, cylindrical shaped leg, inside of which is a first cavity, open at a first end of said second body and coaxial to it.

15 7) Eyeglass frame as per claims 1 through 6 that is distinguished by the fact that on the lateral surface of said first cavity is a first circumferential guide composed of a straight and looping groove that extends for an arch of specific range, for example equal to about 90°, to define, at its opposite ends, a first and second housing.

20 8) Eyeglass frame as per claims 1 through 7 that is distinguished by the fact that said first and second housings, preferably positioned rotated about 90° respectively according to the longitudinal axis of said

first cavity, comprise a protruding curved segment, facing said first end of said second body from the straight segment that joins them.

05 9) Eyeglass frame as per claims 1 through 8 that is distinguished by the fact that beneficially the width of said groove, at its said central, straight segment, is slightly greater than the diameter of said first block to permit sliding.

10 10) Eyeglass frame as per claims 1 through 9 that is distinguished by the fact that said curved segment of said profile of said first and second housings is counter-shaped to said first block to permit the selective housing inside these latter.

11) Eyeglass frame as per claims 1 through 10 that is distinguished by the fact that from said second body protrudes, according to a cord, a second fin, protruding from a second, flat end of said second leg and has a circle arch sectional shape that develops along a generatrix.

15 12) Eyeglass frame as per claims 1 through 11 that is distinguished by the fact that said second fin has a

first flat side that faces the longitudinal axis of said second leg and is preferably parallel to said first housing.

20 13) Eyeglass frame as per claims 1 through 12 that is distinguished by the fact that a bearing, preferably cylindrical shaped, axial to which a second hole is made, preferably threaded, protrudes

orthogonal from said first face, facing about in the same direct of said first housing.

05 14) Eyeglass frame as per claims 1 through 13 that is distinguished by the fact that said first and second hinges comprise an elastically adaptable element, preferably made up of a cylindrical compression rotor spring that can be housed inside said first cavity of said second body and secured, at one of its first ends, on bottom of the latter.

10 15) Eyeglass frame as per claims 1 through 14 that is distinguished by the fact that said first cylindrical leg of said first body can be inserted inside said first cavity, said first block being housed inside said first guide made up of said groove, while said first end of said first leg comes into contact with a second end of said elastically adaptable element.

15 16) Eyeglass frame as per claims 1 through 15 that is distinguished by the fact that said first body is rotationally joined to said second body, since it can rotate along the said longitudinal axis of the said first cavity, so as to selectively pass from a first position, also called the open position, where said first block point is housed inside said first housing, to a second position, also called the folded position, where said 20 first block point is housed inside the said second housing.

17) Eyeglass frame as per claims 1 through 16 that is distinguished by the fact that said first and second hinge are linked to said frontal piece respectively at a first lateral end and a second lateral end of the latter by said bearing.

05 18) Eyeglass frame as per claims 1 through 17 that is distinguished by the fact that said first and second hinges can each restrain a different lens by a fastening screw in the thread made inside said second hole.

10 19) Eyeglass frame as per claims 1 through 18 that is distinguished by the fact that said second flat end of said second leg of said second body acts as a block for a side wall of said lens to prevent any rotation of said first and second hinges around the bearing.

15 20) Eyeglass frame as per claims 1 through 19 that is distinguished by the fact that said first housing of each of said hinges faces down from said frontal piece and is orthogonal to it.

20 21) Eyeglass frame as per claims 1 through 20 that is distinguished by the fact that said first hinge, linked to said frontal piece at its said first end, has said second housing beneficially facing up, while said second hinge, linked to said frontal piece at its said second end, has said second housing beneficially facing down.

22) Eyeglass frame as per claims 1 through 21 that is distinguished by the fact that connected to said frontal piece, in its

central area, is a removable elastic nose piece, preferably made of rubber or other elastic material with a thickness greater than said frontal piece.

05 23) Eyeglass frame as per claims 1 through 22 that is distinguished by the fact that the width of said earpieces is beneficially wider than the thickness of said frontal piece and slightly thinner, at least in their central area, than the thickness of said nose piece, while the length of said earpieces is equal or slightly longer than the distance between the opposite ends of said first and second hinges protruding laterally from said frontal piece.

10 24) Eyeglass frame as per claims 1 through 23 that is distinguished by the fact that each of said, equal earpieces has a front surface with an internal convex profile and rear surface with a concave internal profile, counter-shaped to said front surface so that said earpieces, if longitudinally overlapped, reciprocally match to create a
15 housing.

25) Eyeglass frame as per claims 1 through 24 that is distinguished by the fact that said first and second earpieces have, at one of their front ends, a third housing, open and slightly thicker than the one on said first fin of said first body to permit insertion.

20 26) Eyeglass frame as per claims 1 through 25 that is distinguished by the fact that said third housing is equipped with a pair of

first pins that face each other and protrude from the lower and upper bases of said third housing towards the interior of the latter.

05 27) Eyeglass frame as per claims 1 through 26 that is distinguished by the fact that said first pins, preferably cylindrical, have a diameter slightly smaller than that of said first hole in said first fin so they can be inserted once that latter is housed inside said third housing, creating a rotating connection between said first earpiece and said first hinge and between said second earpiece and said second hinge respectively.

10 28) Eyeglass frame as per claims 1 through 27 that is distinguished by the fact that said third housing is equipped with a bottom, preferably flat, against which said first block surface can be selectively blocked, frontally defined on each said first fin and said second block surface, orthogonal to it.

1/5

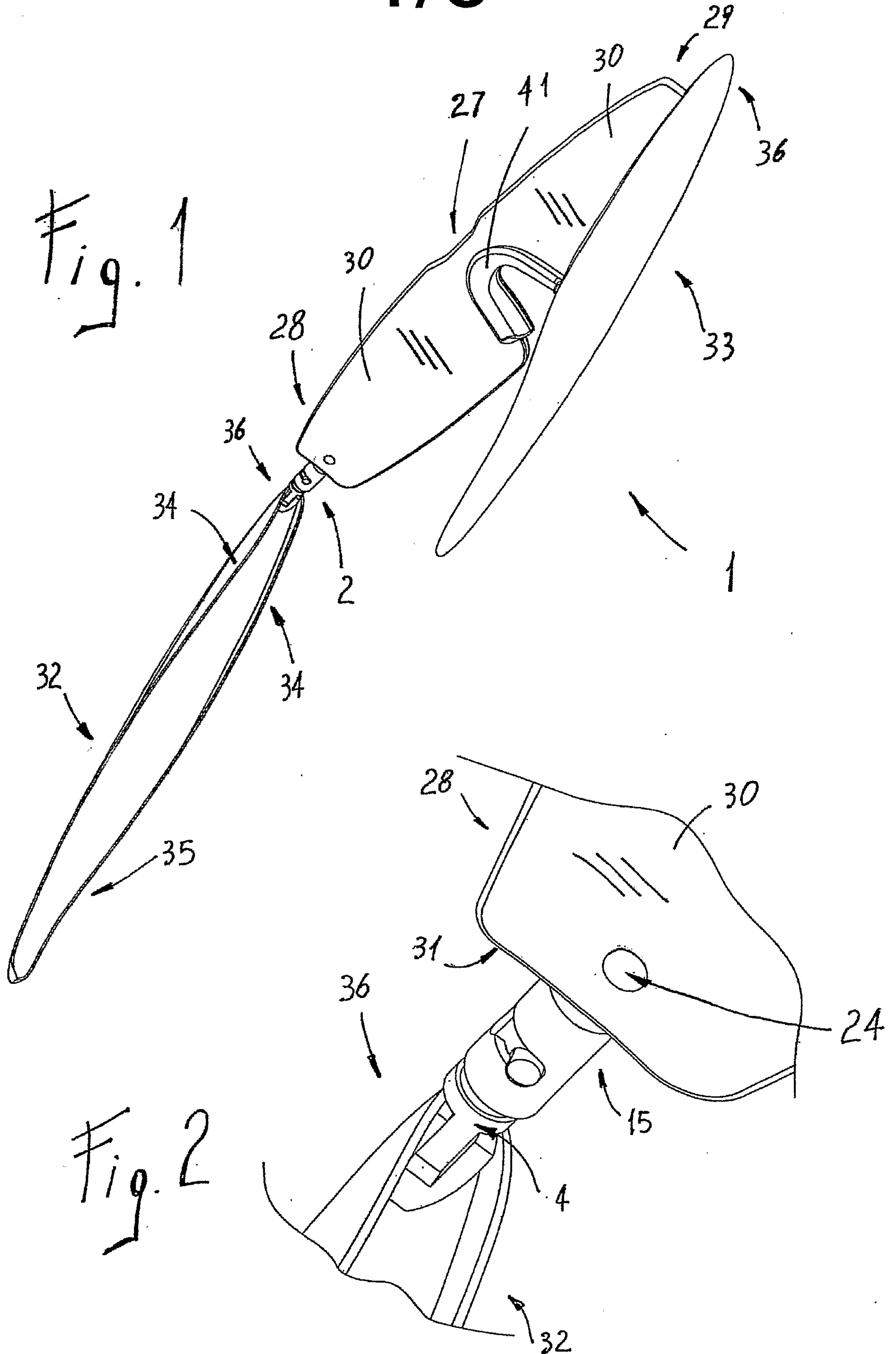

2/5

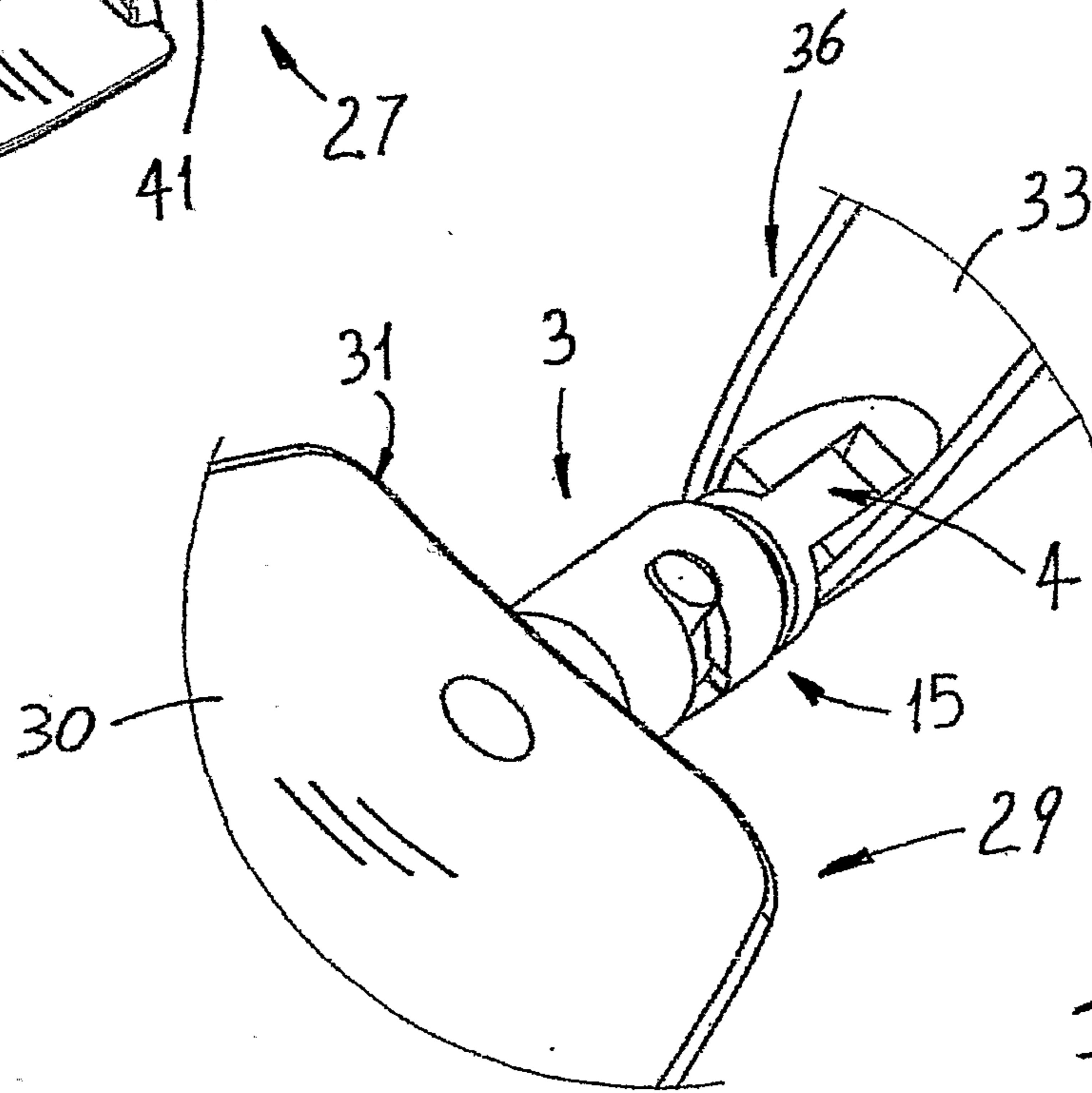
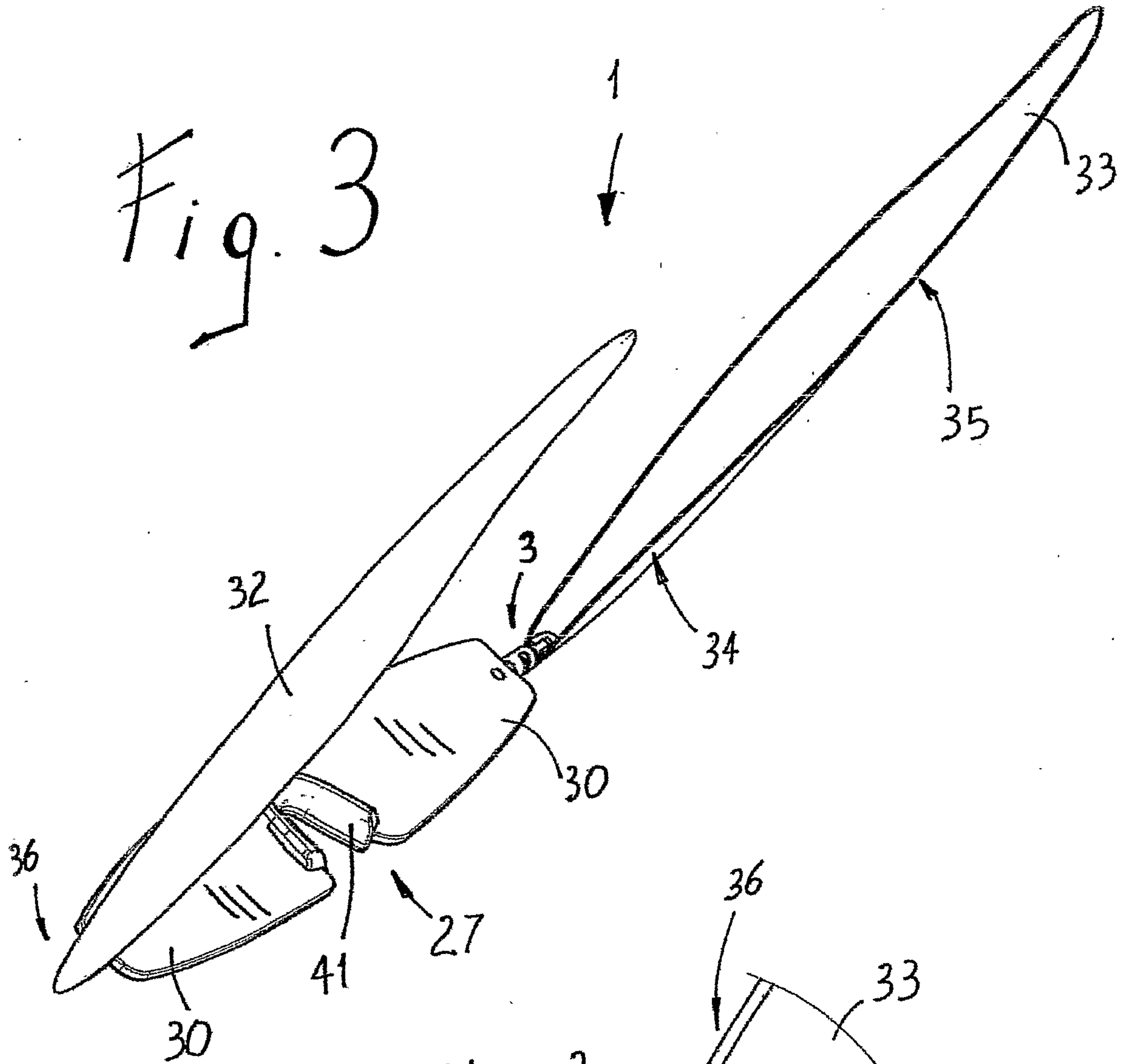
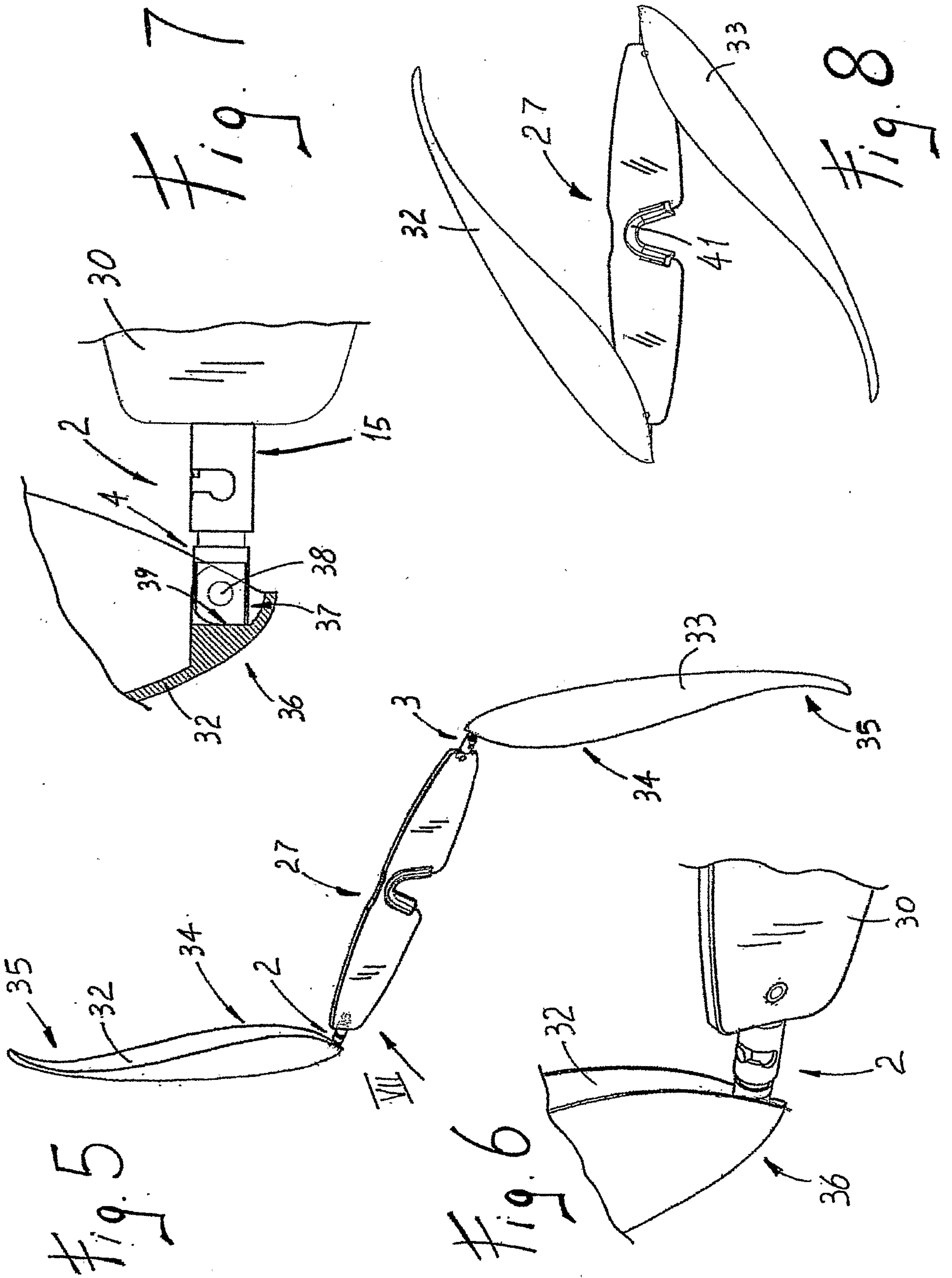

Fig. 4

3/5



4/5

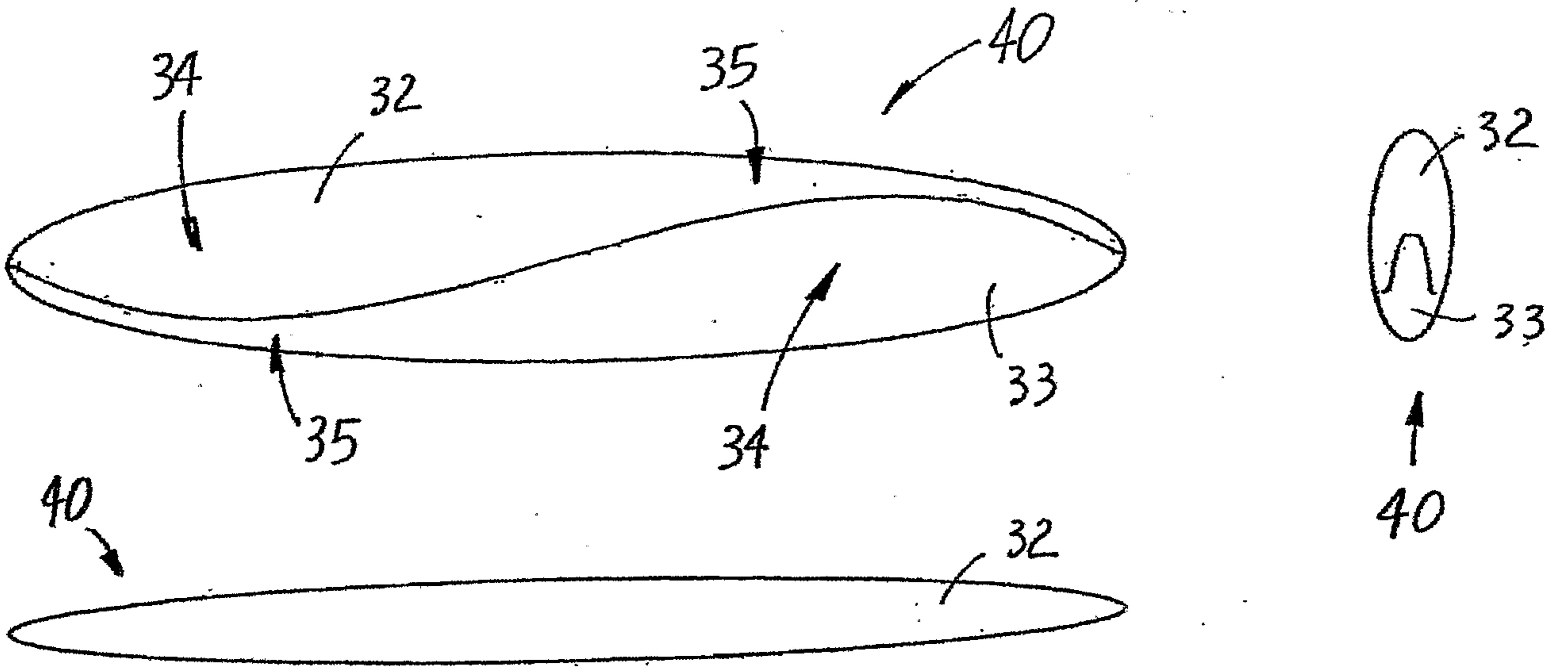

Fig. 9

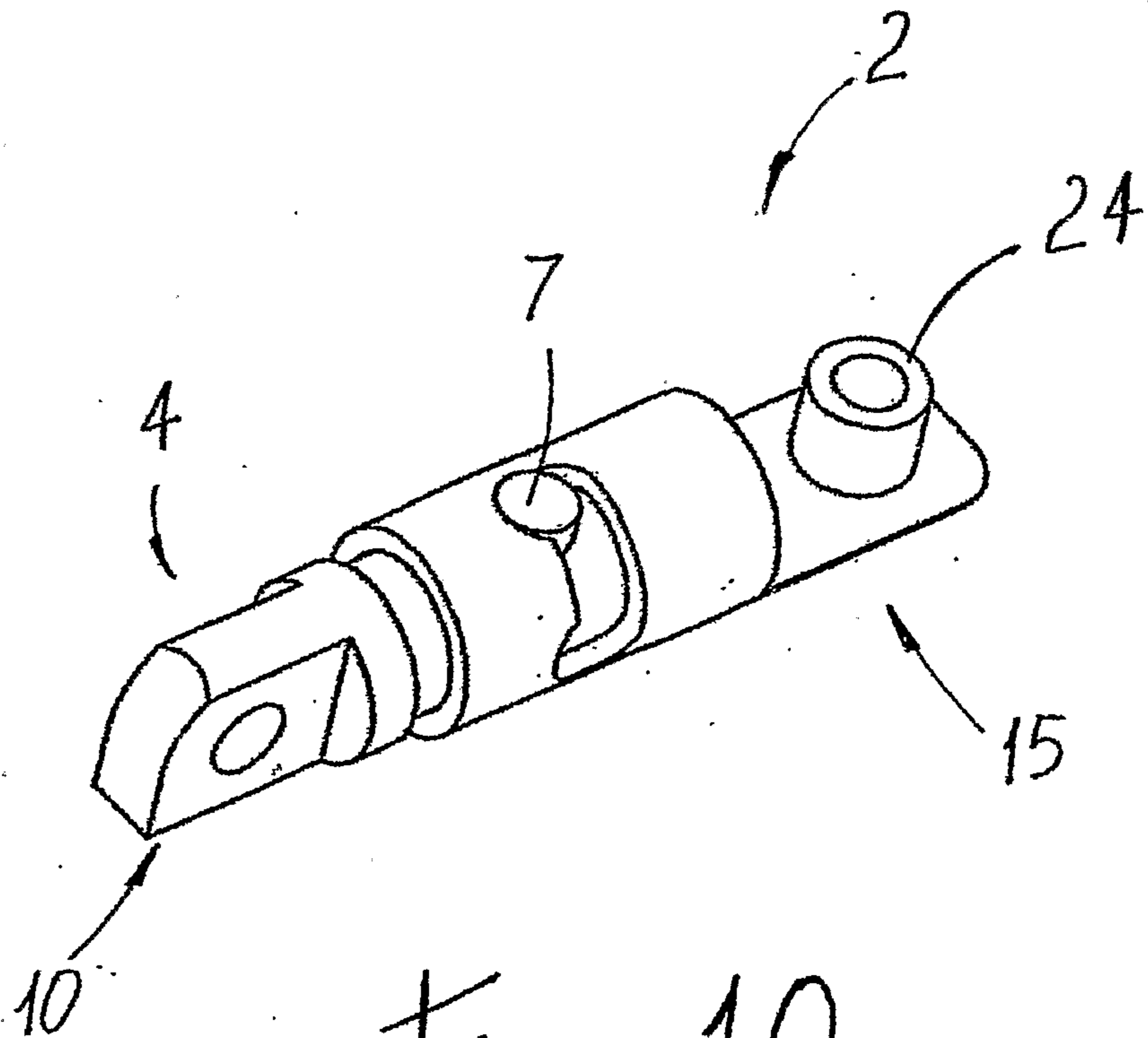

Fig. 10

5/5

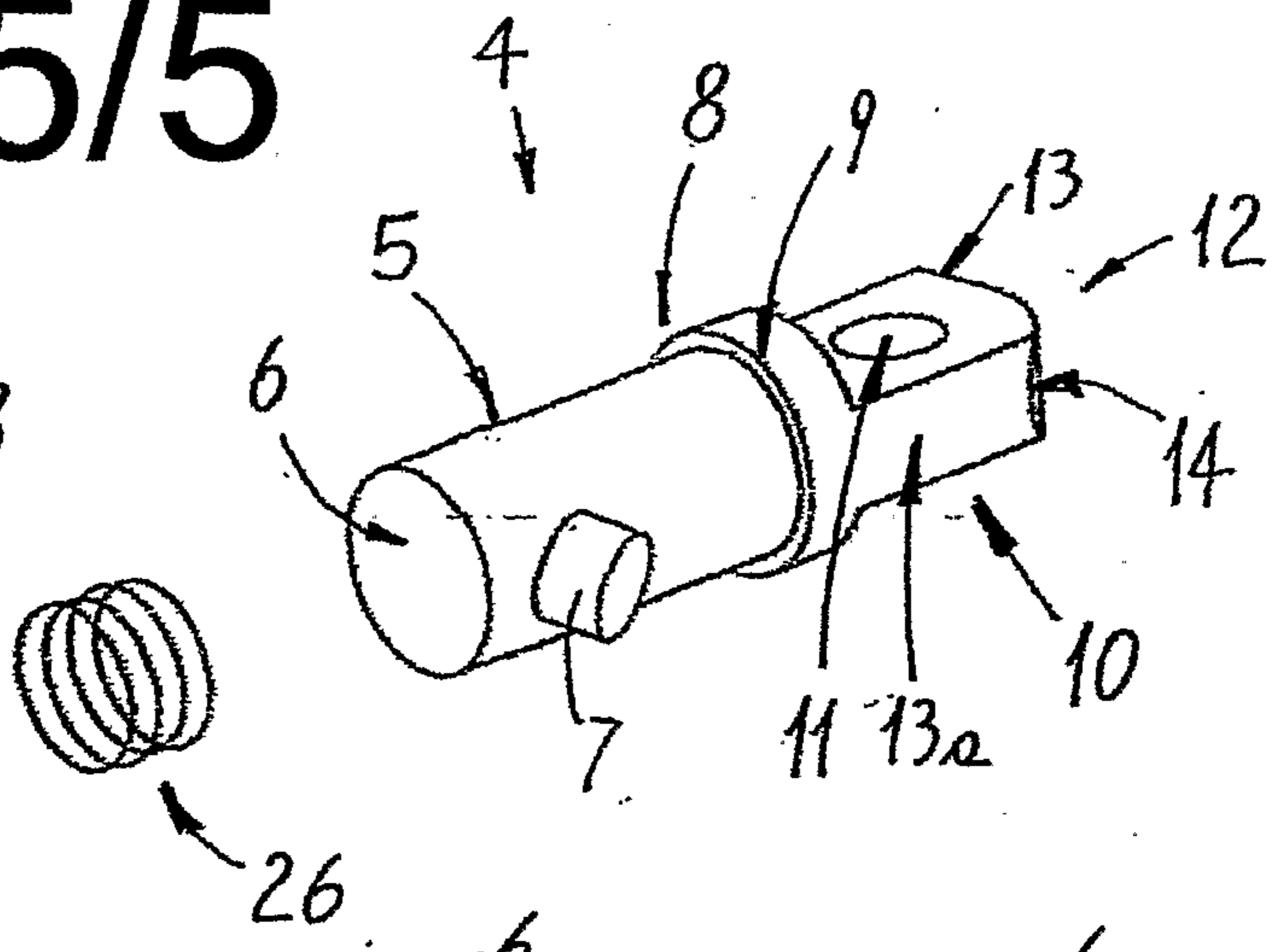
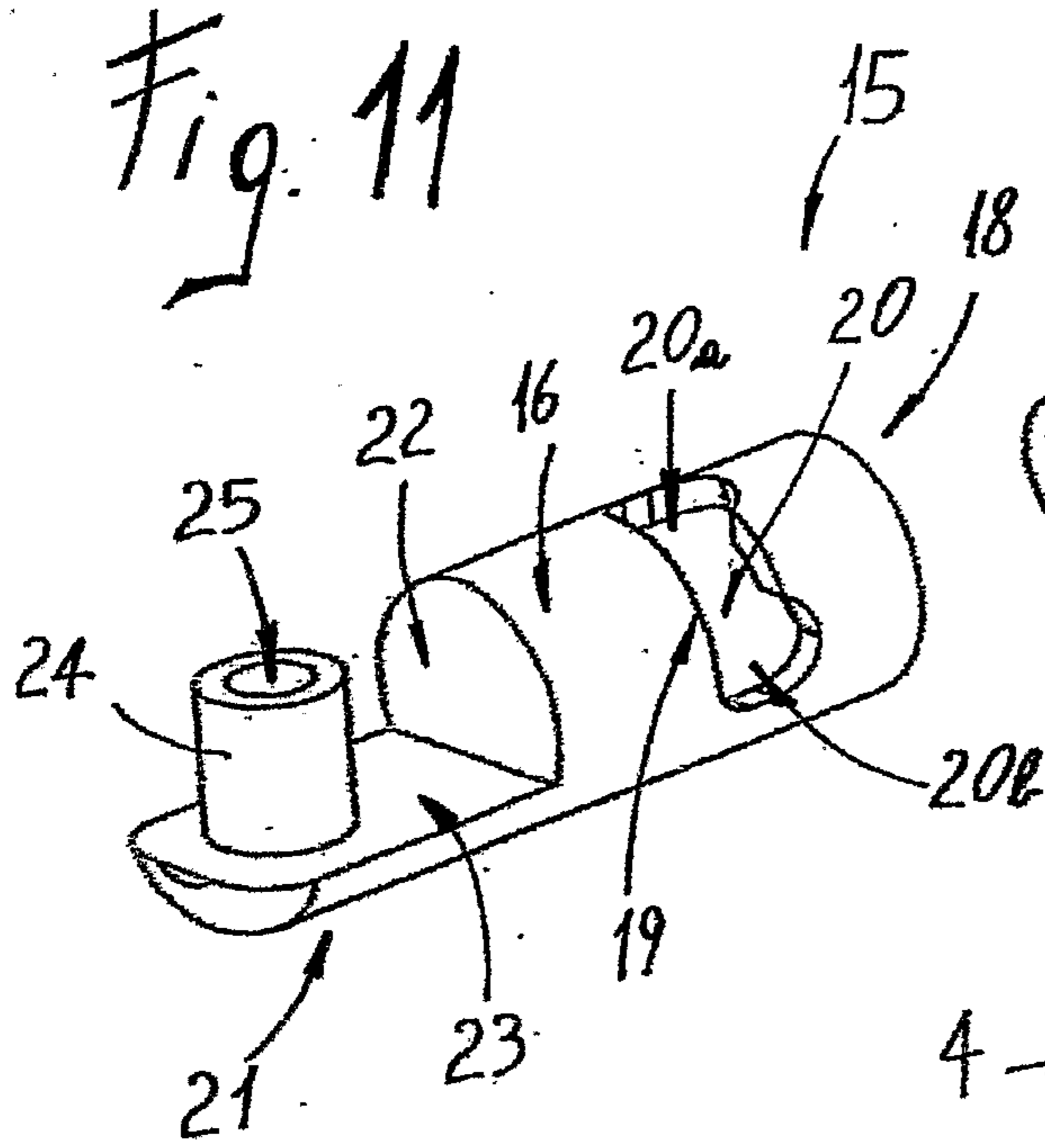

Fig. 12

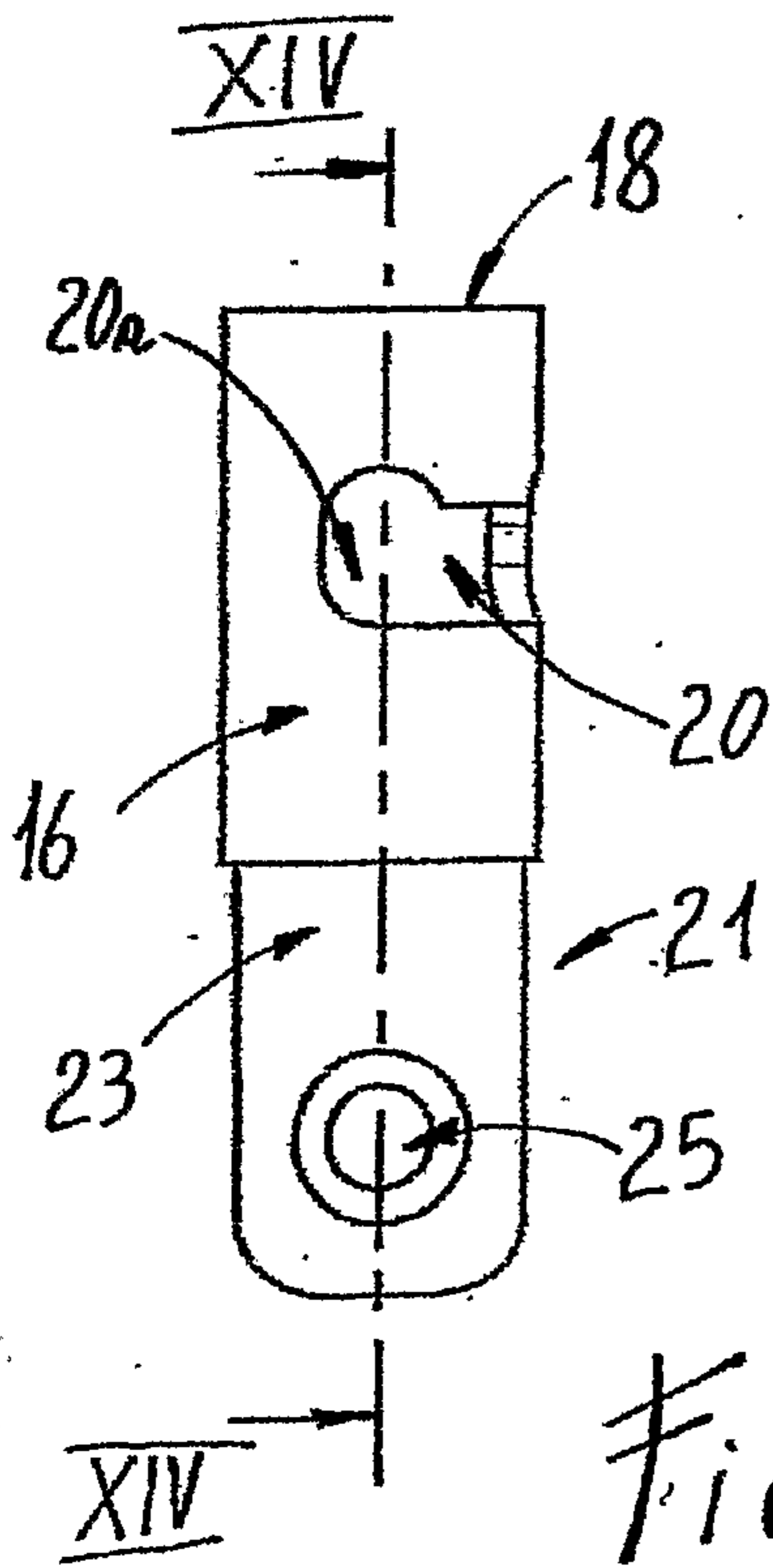
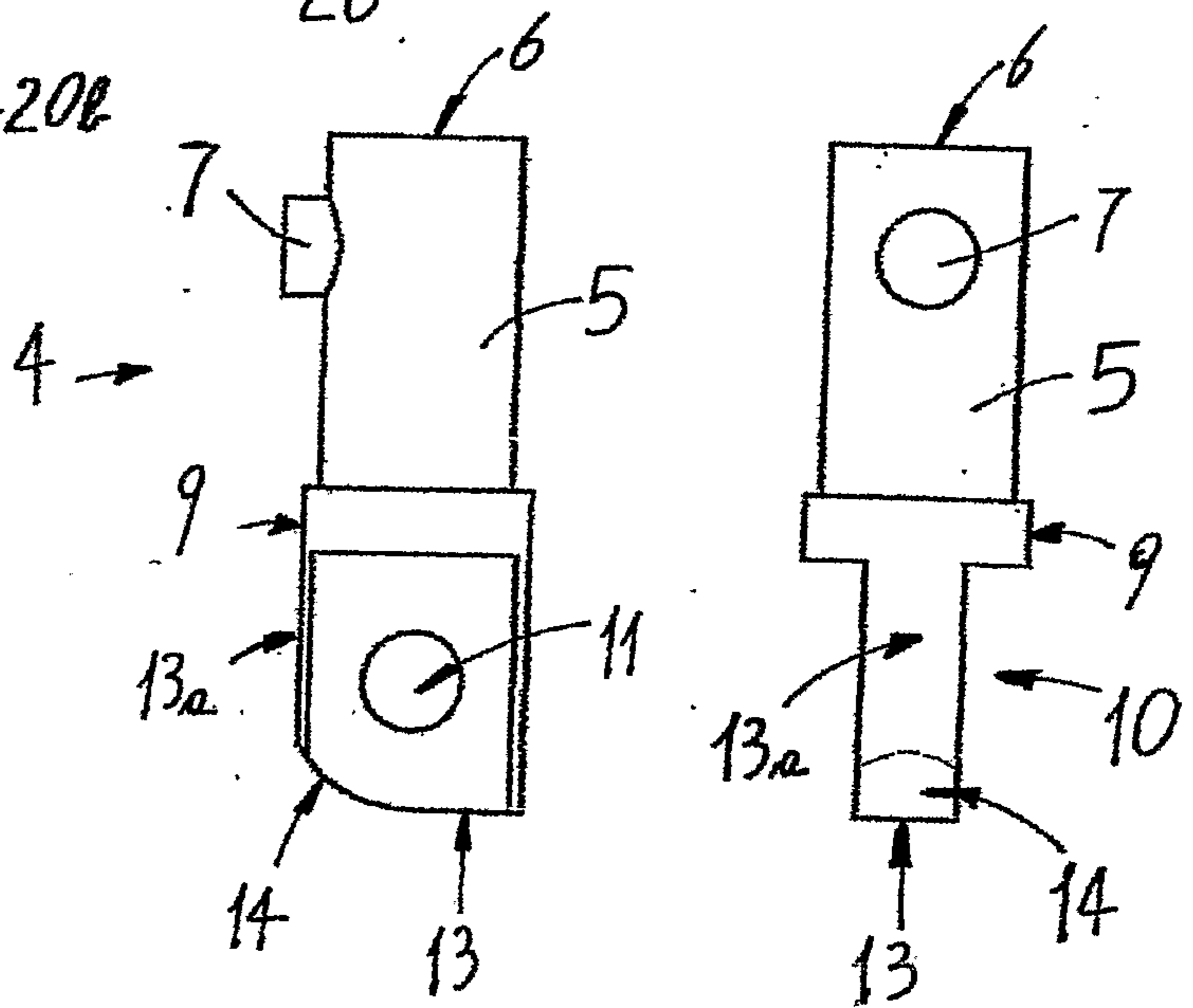

Fig. 13

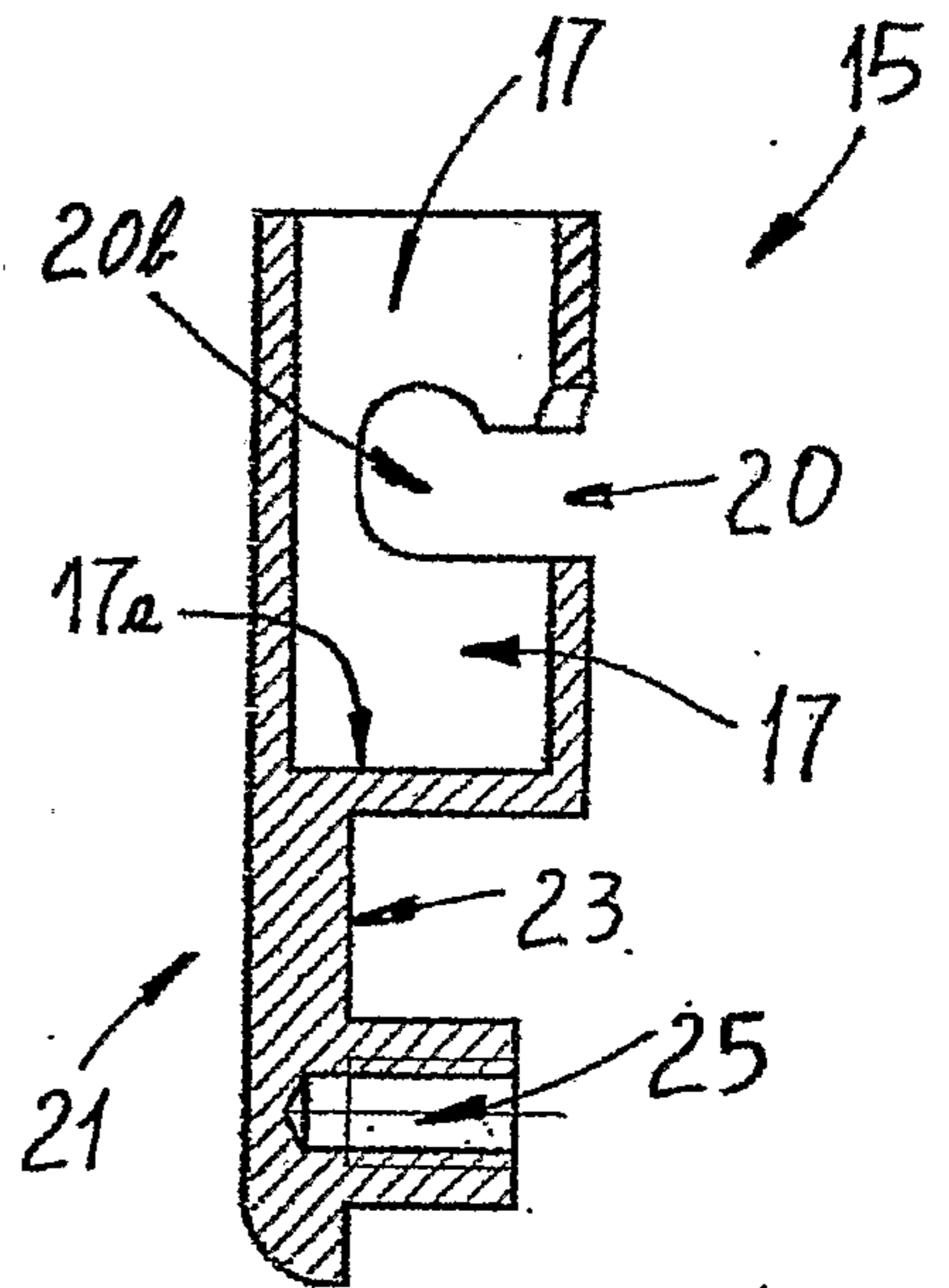
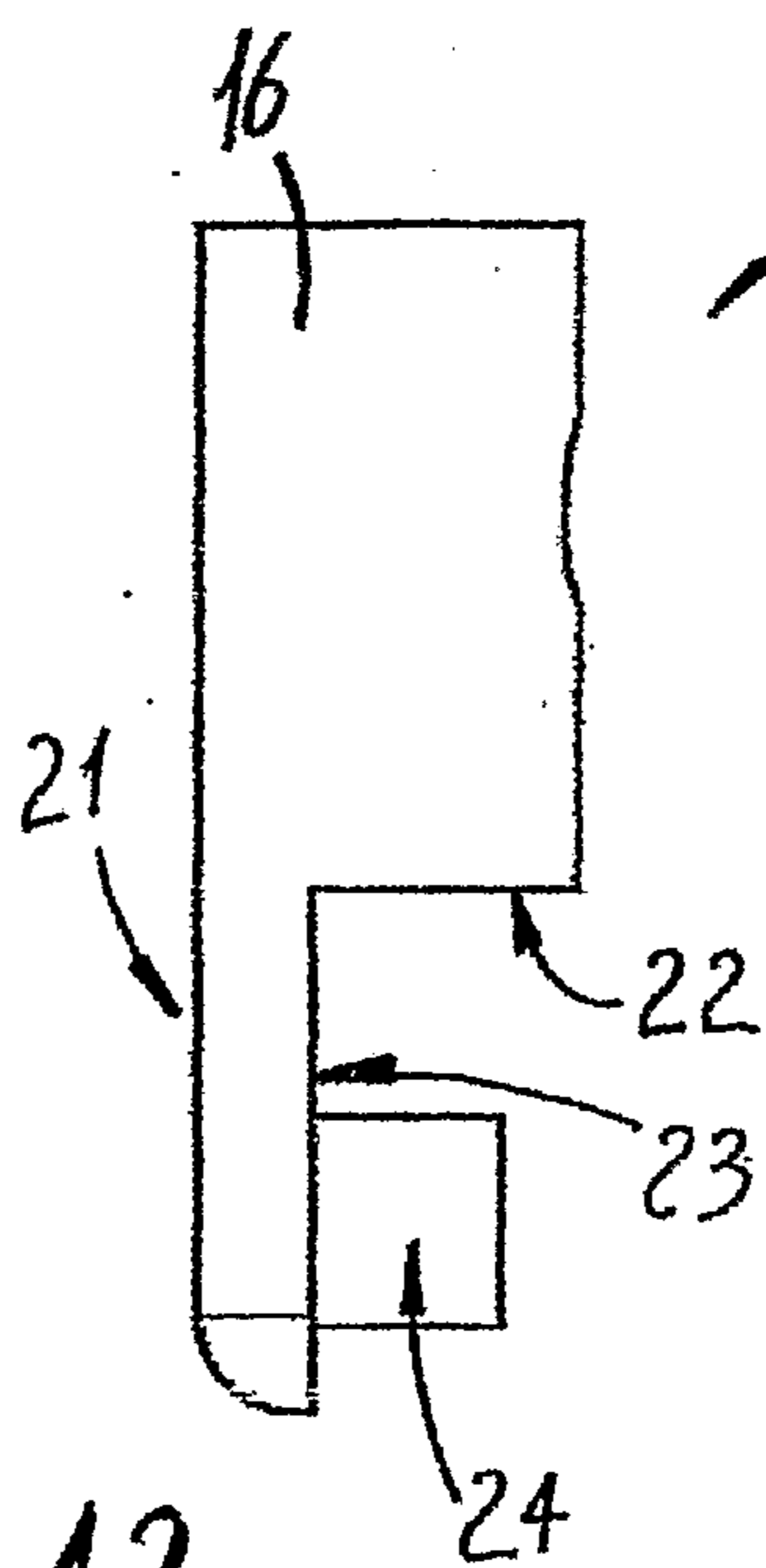

Fig. 14

