



US00D738610S

(12) **United States Design Patent**
Ma

(10) **Patent No.:** **US D738,610 S**

(45) **Date of Patent:** **** Sep. 15, 2015**

(54) **UMBRELLA RUNNER**

(71) Applicant: **Oliver Joen-an Ma**, Arcadia, CA (US)

(72) Inventor: **Oliver Joen-an Ma**, Arcadia, CA (US)

(**) Term: **14 Years**

(21) Appl. No.: **29/467,500**

(22) Filed: **Sep. 19, 2013**

(51) **LOC (10) Cl.** **03-03**

(52) **U.S. Cl.**

USPC **D3/10**

(58) **Field of Classification Search**

USPC D3/5, 10; D6/320, 328; D8/83, 106,
D8/311, 310, 312, 314, 354, 375, DIG. 8;
135/16, 19.5, 22, 27, 28, 39

CPC A45B 2025/003; A45B 2025/06;
A45B 2025/105

See application file for complete search history.

(56) **References Cited**

U.S. PATENT DOCUMENTS

90,883 A	6/1869	Smith
D33,847 S	1/1901	Gaskill
878,270 A	2/1908	Blake et al.
956,657 A	5/1910	Wetteroth
957,528 A	5/1910	Wetteroth
D45,227 S	2/1914	Glauber
1,136,887 A	4/1915	Penn
1,235,296 A	7/1917	Dillingham
1,243,594 A	10/1917	Dillingham
1,255,627 A	2/1918	Morrow et al.
1,268,354 A	6/1918	Howard
D90,772 S	9/1933	Kasch
D127,735 S	6/1941	Dreyfuss
2,447,972 A	8/1948	Weinert
2,475,406 A	7/1949	Russell

(Continued)

FOREIGN PATENT DOCUMENTS

CN 202190859 4/2012
DE 3820573 8/1989

(Continued)

OTHER PUBLICATIONS

Operation Manual Easy Sun Parasol Sunshade (Issue: Jul. 2004) pp. 1-17.

Primary Examiner — Sheryl Lane

Assistant Examiner — Catherine Posthauer

(74) *Attorney, Agent, or Firm* — Knobbe Martens Olson & Bear, LLP

(57) **CLAIM**

The ornamental designs for an umbrella runner, as shown and described.

DESCRIPTION

FIG. 1 is an environmental perspective view of the umbrella runner, as illustrated in FIG. 2, in a position of use.

FIG. 2 is a top perspective view of the umbrella runner.

FIG. 3 is a bottom perspective view of the umbrella runner of FIG. 2;

FIG. 4 is a front view of the umbrella runner of FIG. 2;

FIG. 5 is a rear view of the umbrella runner of FIG. 2;

FIG. 6 is a right view of the umbrella runner of FIG. 2;

FIG. 7 is a left view of the umbrella runner of FIG. 2;

FIG. 8 is a top view of the umbrella runner of FIG. 2; and,

FIG. 9 is a bottom view of the umbrella runner of FIG. 2.

The broken lines are shown for the purpose of indicating environmental structure and portions of the umbrella runner and form no part of the claimed design.

1 Claim, 8 Drawing Sheets

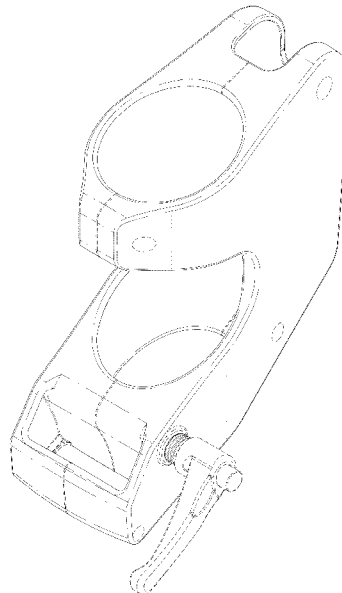
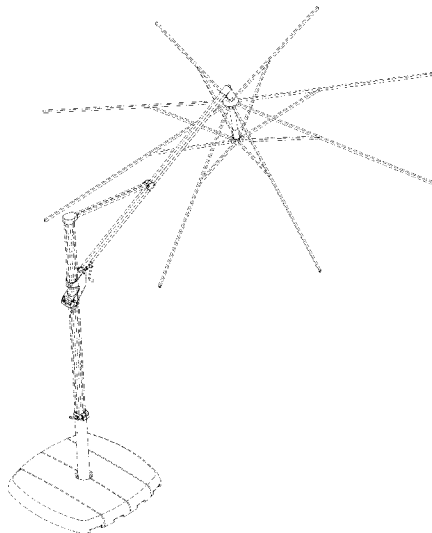

(56)

References Cited

U.S. PATENT DOCUMENTS

D162,678 S	3/1951	Muller-Munk	6,575,183 B2	6/2003	Tung	
D167,619 S	9/1952	Coran	D477,458 S	7/2003	Goldwitz	
2,661,752 A *	12/1953	Kampf et al.	6,588,438 B1	7/2003	Steiner	
2,762,383 A	9/1956	Wittman	D478,416 S	8/2003	Clarke	
2,937,653 A	5/1960	Danciart et al.	6,619,306 B2	9/2003	Ma	
D190,597 S	6/1961	Nelson	6,662,815 B2	12/2003	Tung	
3,120,238 A	2/1964	Glatz	6,732,753 B2	5/2004	Chang	
3,145,720 A	8/1964	Torii	6,758,229 B2	7/2004	Wang	
3,424,180 A	1/1969	Giancarlo	D497,478 S	10/2004	Clarke	
3,856,032 A	12/1974	Schafer	D497,479 S	10/2004	Yu	
D265,498 S	7/1982	Paul	D498,917 S *	11/2004	Goldwitz	D3/10
4,368,749 A	1/1983	Lindler et al.	6,837,255 B2	1/2005	Bunch et al.	
D276,838 S	12/1984	Hill et al.	6,851,823 B2	2/2005	Bilotti	
4,586,525 A	5/1986	Glatz et al.	D503,035 S	3/2005	Ko	
D285,862 S *	9/1986	Levy	D503,272 S	3/2005	Machin et al.	
4,622,987 A	11/1986	Redl et al.	6,871,659 B2 *	3/2005	Tung	135/20.3
4,674,523 A	6/1987	Glatz	6,889,699 B2	5/2005	Clarke	
4,697,606 A	10/1987	Ma	6,923,193 B2	8/2005	Chen	
D292,947 S *	12/1987	Levy	6,941,960 B2	9/2005	Huang	
4,811,670 A	3/1989	Kolvites et al.	7,000,624 B2	2/2006	Chang	
4,878,509 A	11/1989	Tung	D518,629 S	4/2006	Ma	
5,002,081 A	3/1991	Stromeyer	D525,721 S	7/2006	Landes	
5,029,596 A	7/1991	Tung	7,082,953 B2	8/2006	Liu	
5,050,627 A	9/1991	Hengtzu	7,089,950 B2	8/2006	Lin	
D321,779 S	11/1991	Ma	7,134,442 B2	11/2006	Ma	
D344,786 S	3/1994	Short et al.	D539,632 S	4/2007	Ma	
5,349,975 A	9/1994	Valdner	7,293,573 B2	11/2007	Clarke	
5,357,994 A	10/1994	Chung	D558,444 S	1/2008	Ma	
D360,522 S	7/1995	Ko	7,318,444 B2	1/2008	Clakre	
5,499,644 A	3/1996	Geniele	7,328,715 B2	2/2008	Neubardt	
D372,854 S	8/1996	Jimenez	7,341,068 B2	3/2008	Liu	
5,584,564 A	12/1996	Phyle	D574,144 S *	8/2008	Ortiz-Gavin	D3/10
5,588,455 A	12/1996	Kuo	7,546,845 B2	6/2009	Prusmack	
5,611,364 A	3/1997	Woods et al.	7,556,051 B2	7/2009	Lai	
5,655,557 A	8/1997	Martin	D602,686 S *	10/2009	Patzak	D3/10
5,740,823 A	4/1998	Lin et al.	D609,453 S *	2/2010	Liu	D3/5
5,785,069 A	7/1998	Glatz	7,665,477 B1	2/2010	Hathaway	
D397,054 S	8/1998	Brantley et al.	7,686,024 B1	3/2010	Lai	
5,794,637 A	8/1998	Figueroa	7,703,464 B2	4/2010	Ma	
D398,443 S	9/1998	Bolle	7,708,022 B2	5/2010	Ma	
5,809,734 A	9/1998	Turner	D621,600 S *	8/2010	He	D3/5
D400,777 S	11/1998	Carsello	D623,395 S *	9/2010	Liao	D3/10
5,884,645 A	3/1999	Chen et al.	D626,324 S	11/2010	Ma	
D408,621 S	4/1999	Kuo	D631,243 S	1/2011	Forthuber et al.	
5,899,210 A	5/1999	Letherby et al.	7,861,734 B2	1/2011	Ma	
D410,862 S	6/1999	Milhov	7,891,367 B2	2/2011	Ma	
5,937,882 A	8/1999	Harbaugh	7,900,643 B2	3/2011	Ma	
5,960,806 A	10/1999	Steiner	7,913,708 B2	3/2011	Yung	
6,014,980 A	1/2000	Glatz	D638,622 S *	5/2011	He	D3/5
6,076,540 A	6/2000	You	D644,832 S *	9/2011	Patzak	D3/10
D434,215 S	11/2000	Lin	8,061,375 B2	11/2011	Ma	
D434,476 S	11/2000	Meda	8,082,935 B2	12/2011	Ma	
6,145,523 A	11/2000	Lo	8,096,310 B2	1/2012	Clarke	
6,152,156 A	11/2000	Tung	D668,445 S *	10/2012	Patzak	D3/10
D434,556 S	12/2000	Lin	D719,343 S	12/2014	Ma	
6,192,907 B1	2/2001	Wu	2002/0083969 A1	7/2002	Tung	
6,220,261 B1	4/2001	Glatz	2002/0129847 A1 *	9/2002	Ma	135/98
6,230,728 B1	5/2001	Reese	2002/0139405 A1	10/2002	Lee	
6,247,483 B1	6/2001	Tung	2003/0015228 A1 *	1/2003	Liu	135/16
6,298,867 B1	10/2001	Chang	2003/0015229 A1 *	1/2003	Ma	135/16
6,305,394 B1	10/2001	Reese	2003/0015230 A1	1/2003	Glatz	
6,311,705 B1	11/2001	Ma	2003/0234033 A1 *	12/2003	Lai	135/20.3
6,311,707 B1	11/2001	Wu et al.	2004/0031513 A1	2/2004	Bunch et al.	
6,314,976 B1	11/2001	Clarke	2004/0055627 A1	3/2004	Moga	
6,371,141 B1	4/2002	Lin et al.	2004/0055628 A1	3/2004	Yu	
6,371,686 B1	4/2002	Wu	2004/0069333 A1	4/2004	Ma	
6,386,214 B1	5/2002	Clarke	2004/0154525 A1	8/2004	Wirth et al.	
6,386,215 B1	5/2002	Chang	2004/0182429 A1	9/2004	Chen	
6,412,506 B1	7/2002	Reese	2004/0206382 A1	10/2004	Clarke	
6,422,251 B1	7/2002	Tseng	2004/0206383 A1	10/2004	Clarke	
6,435,444 B1	8/2002	Lin	2005/0098200 A1	5/2005	Su	
D465,915 S *	11/2002	Earnshaw	2005/0194027 A1	9/2005	Ko	
6,478,037 B2	11/2002	Tung	2006/0005867 A1	1/2006	Chang	
6,571,813 B2	6/2003	Lin et al.	2006/0151019 A1	7/2006	Lo	
6,575,182 B2	6/2003	Tung	2008/0066793 A1	3/2008	Ma	
			2008/0202570 A1	8/2008	Clarke	
			2009/0007945 A1	1/2009	Ma	
			2009/0260664 A1	10/2009	Ma	
			2010/0139724 A1	6/2010	Lai	

(56)

References Cited

FOREIGN PATENT DOCUMENTS

U.S. PATENT DOCUMENTS

2010/0139725	A1	6/2010	Lai
2011/0061694	A1	3/2011	Vanderminden, Sr.
2011/0132418	A1	6/2011	Ma
2011/0209732	A1	9/2011	Ma
2011/0214705	A1	9/2011	Ma
2011/0277800	A1	11/2011	Tung
2013/0276843	A1	10/2013	Ma
2014/0251394	A1	9/2014	Ma

FR	2672781	A3	8/1992
JP	2006-110317	A	4/2006
JP	2007-222591		9/2007
JP	2008-142310		6/2008
WO	WO 2005/058089		6/2005

* cited by examiner

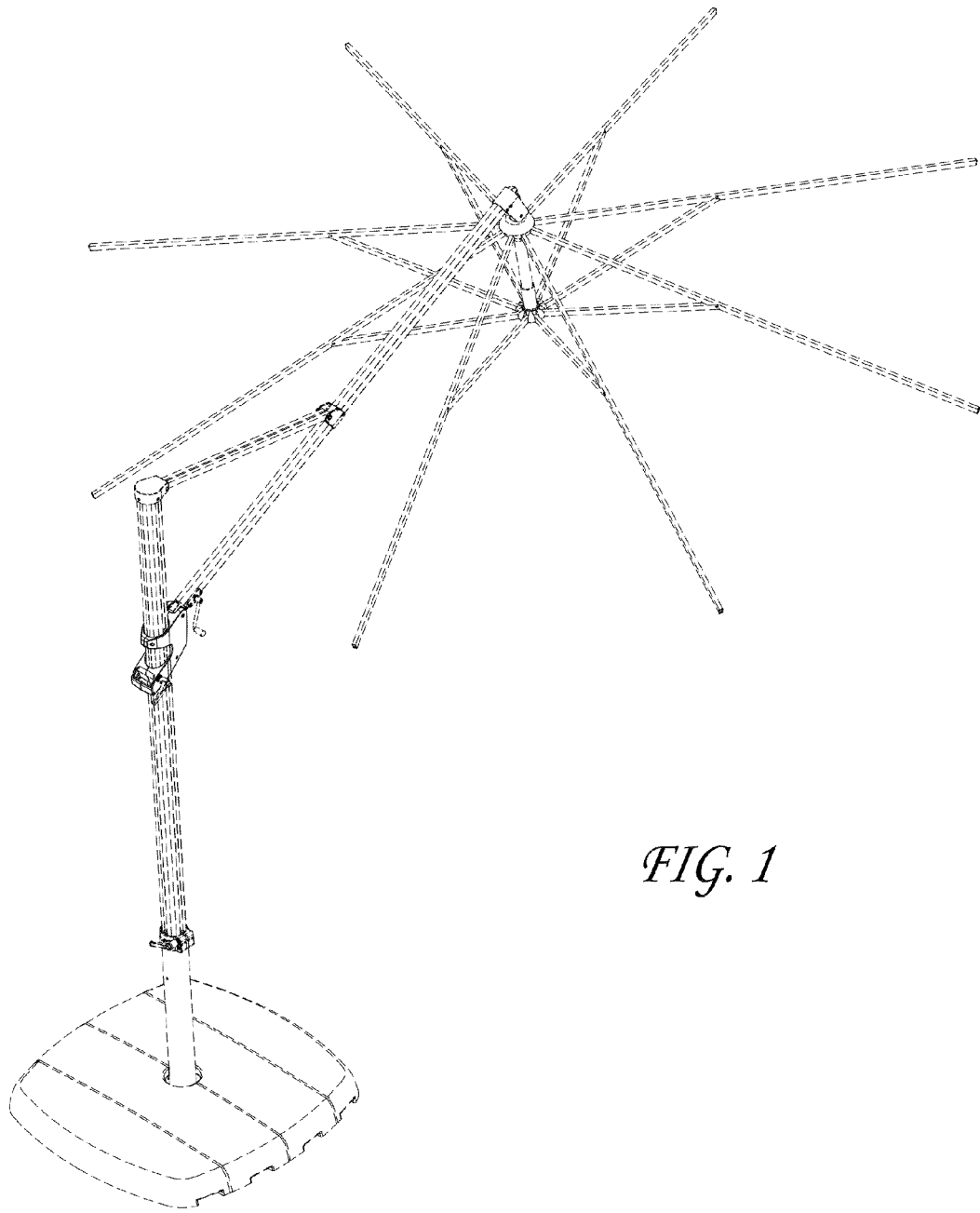

FIG. 1

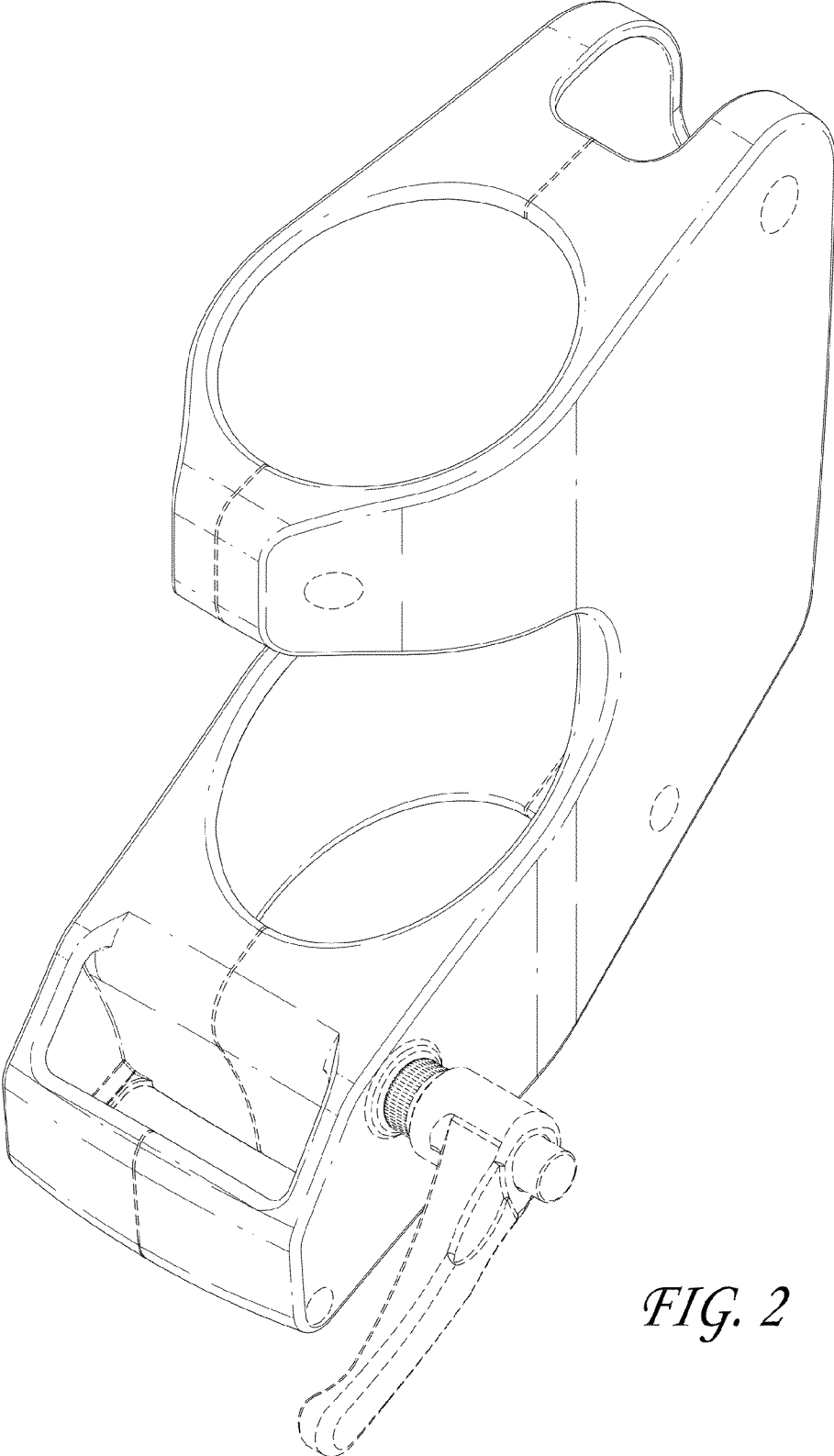

FIG. 2

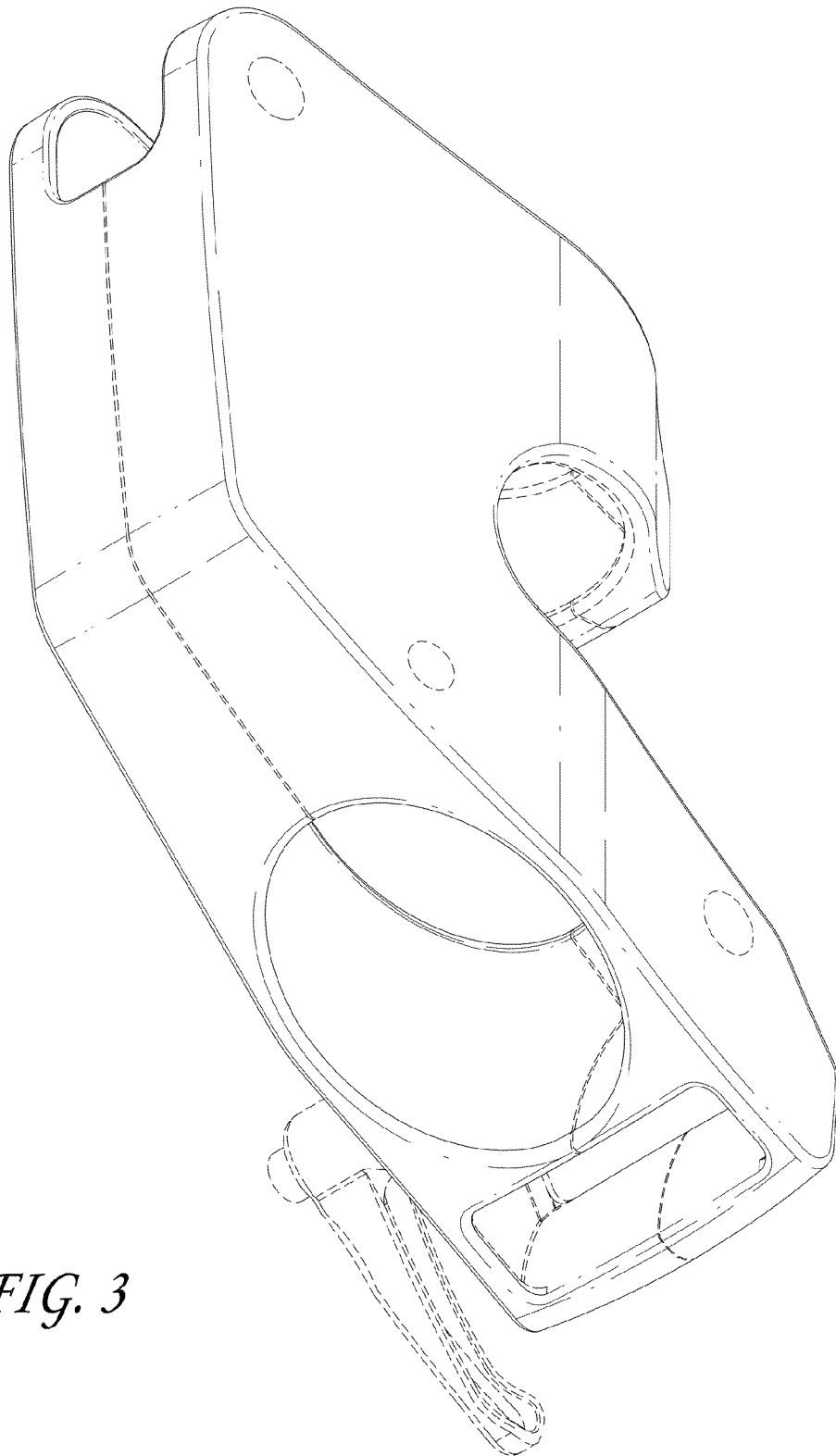

FIG. 3

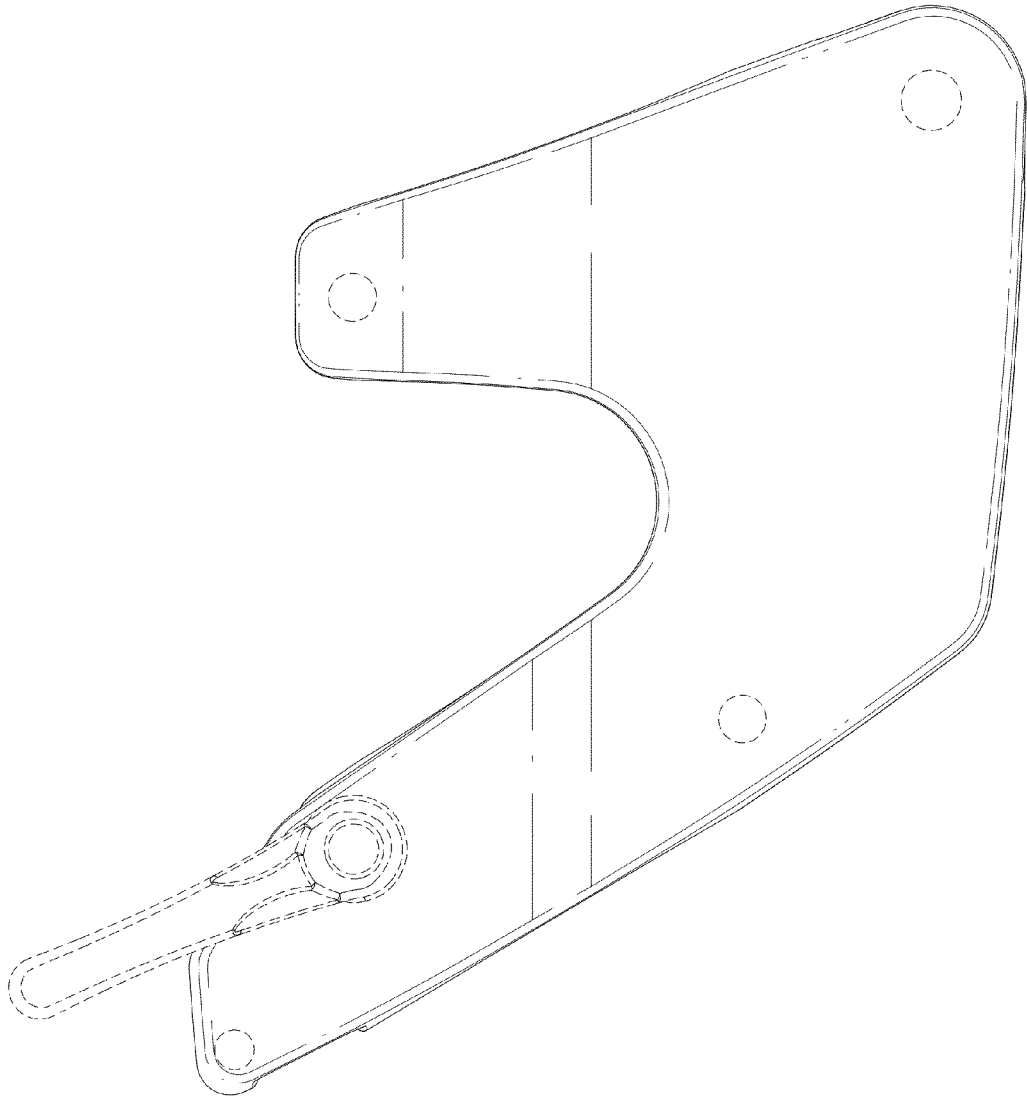

FIG. 4

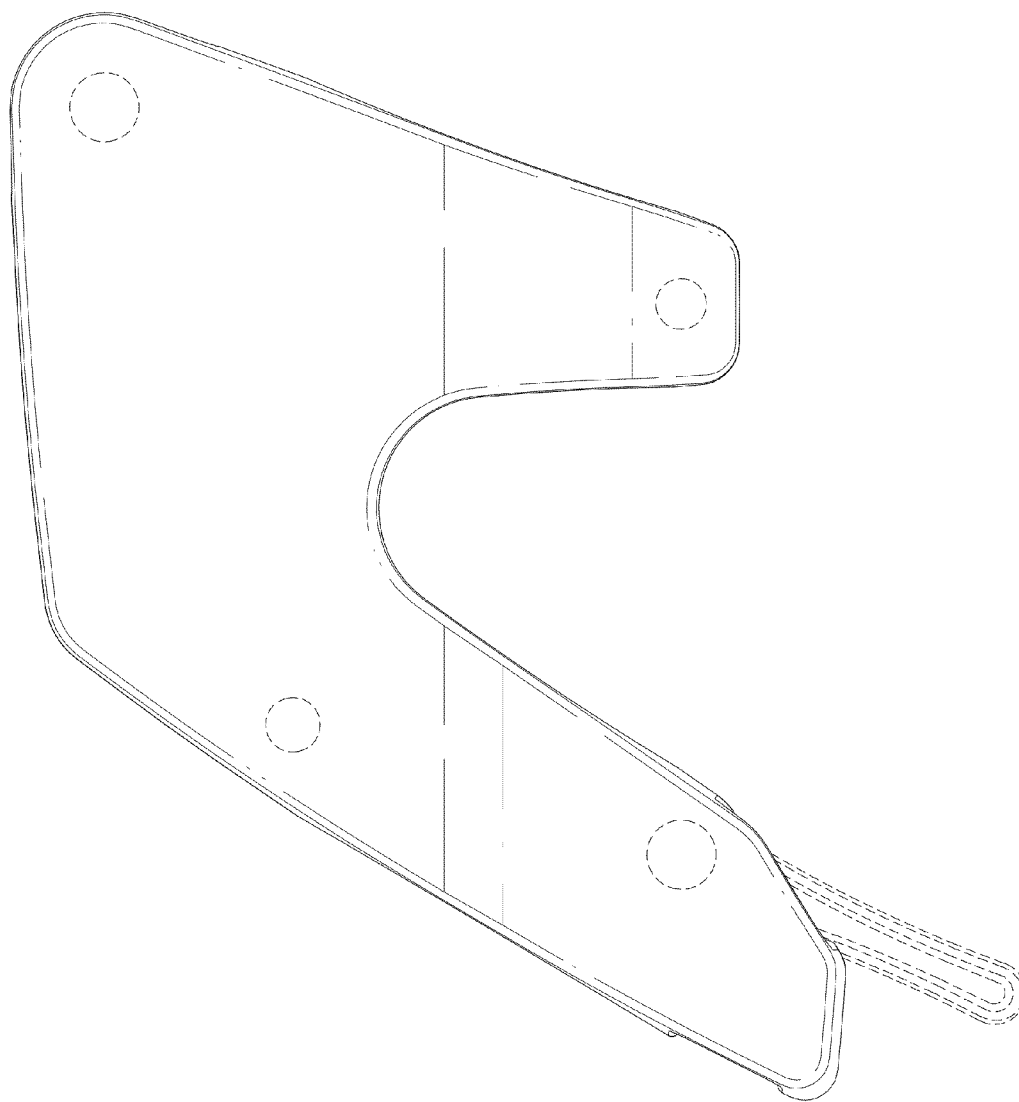

FIG. 5

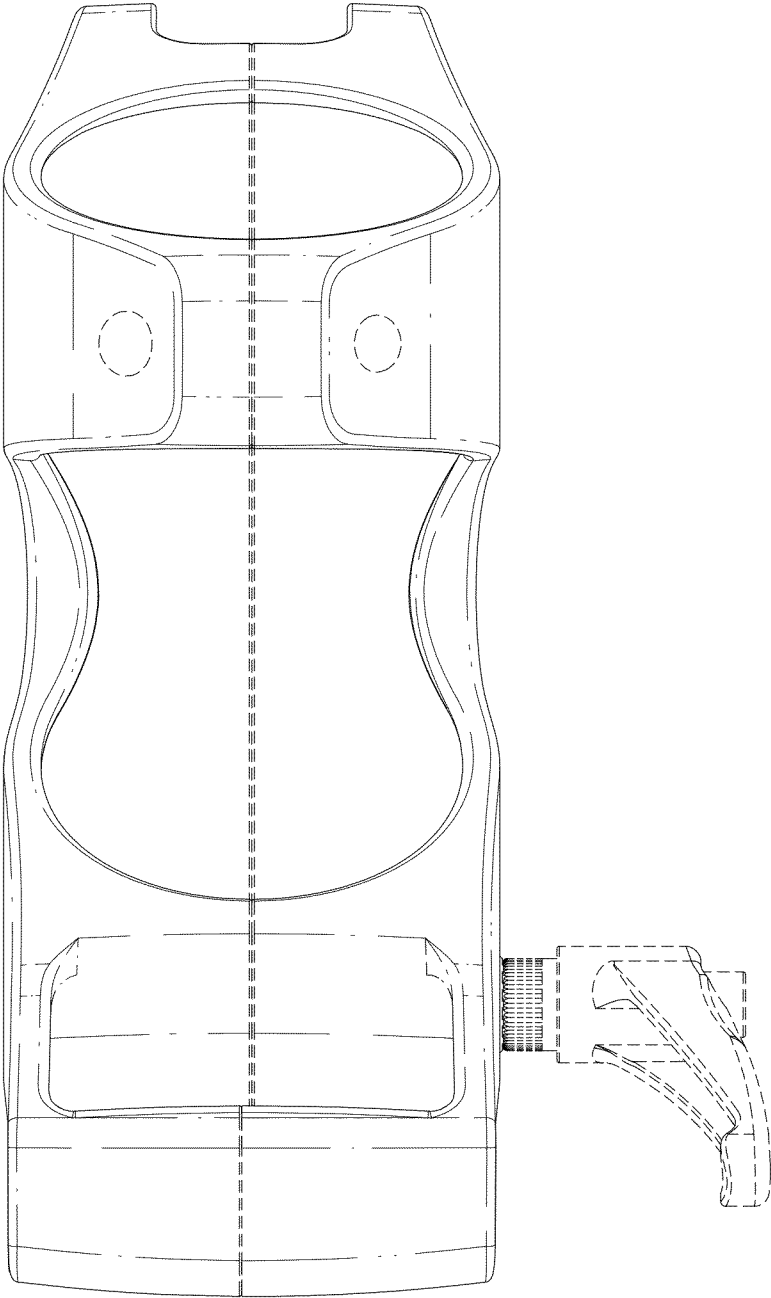

FIG. 6

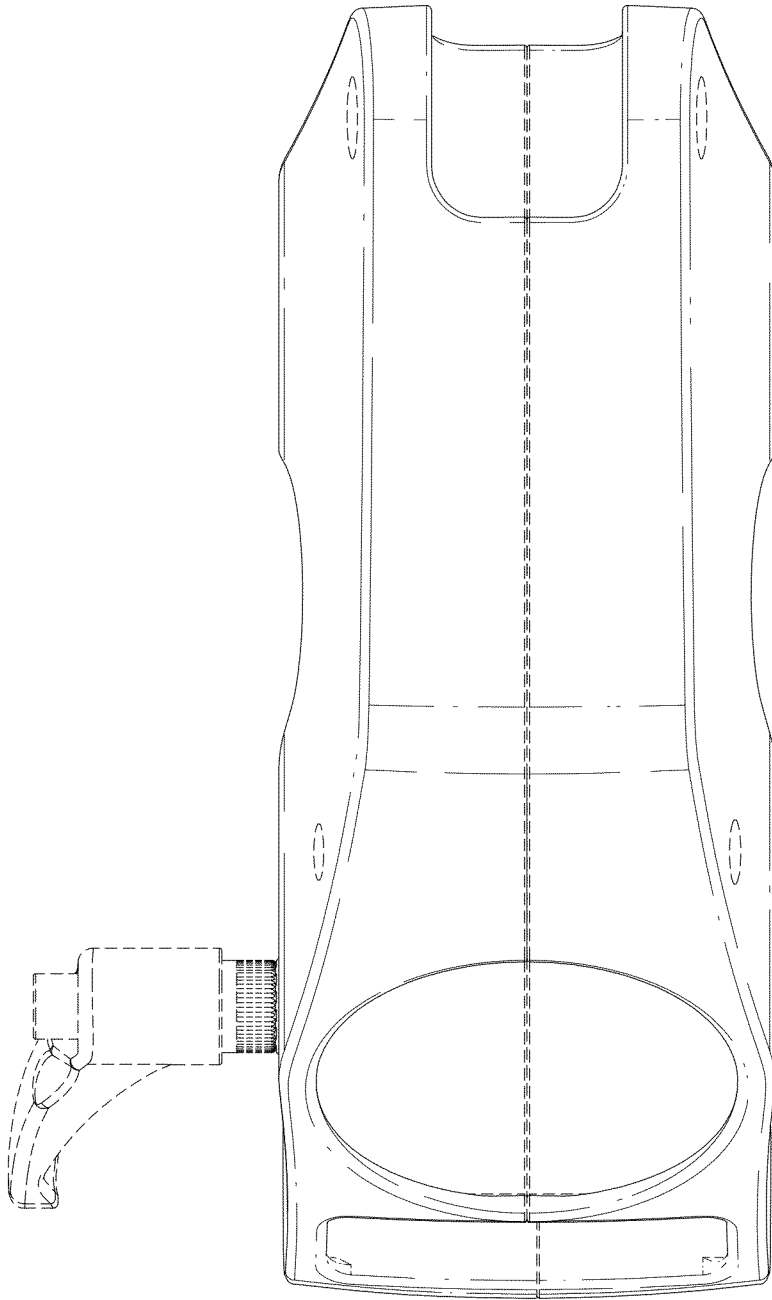

FIG. 7

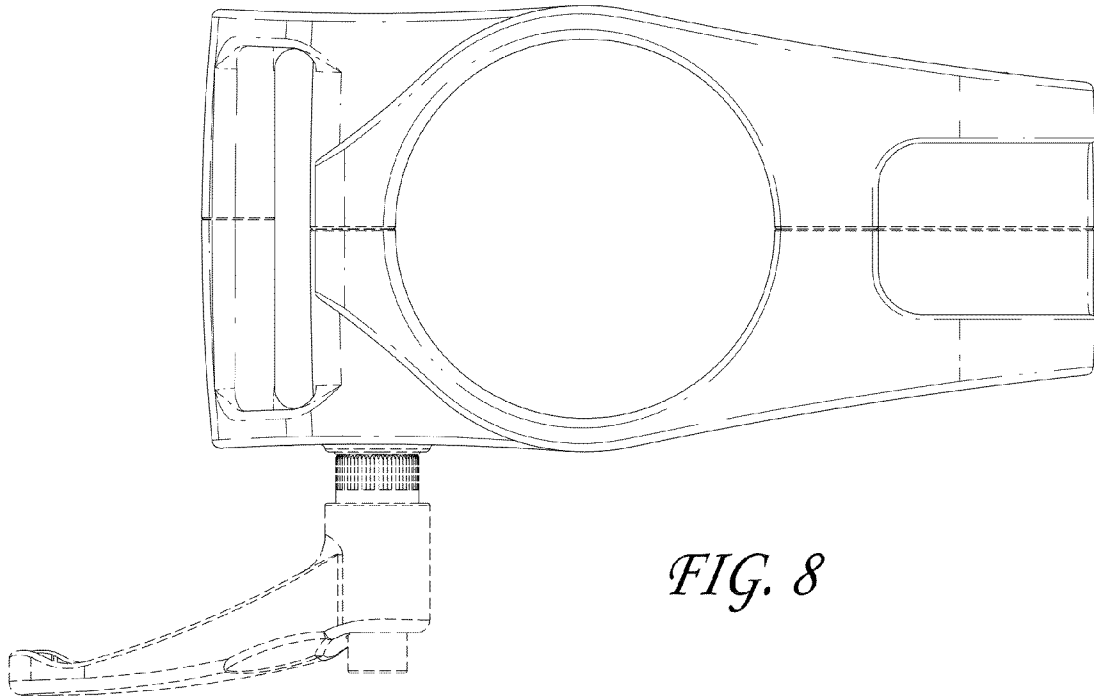

FIG. 8

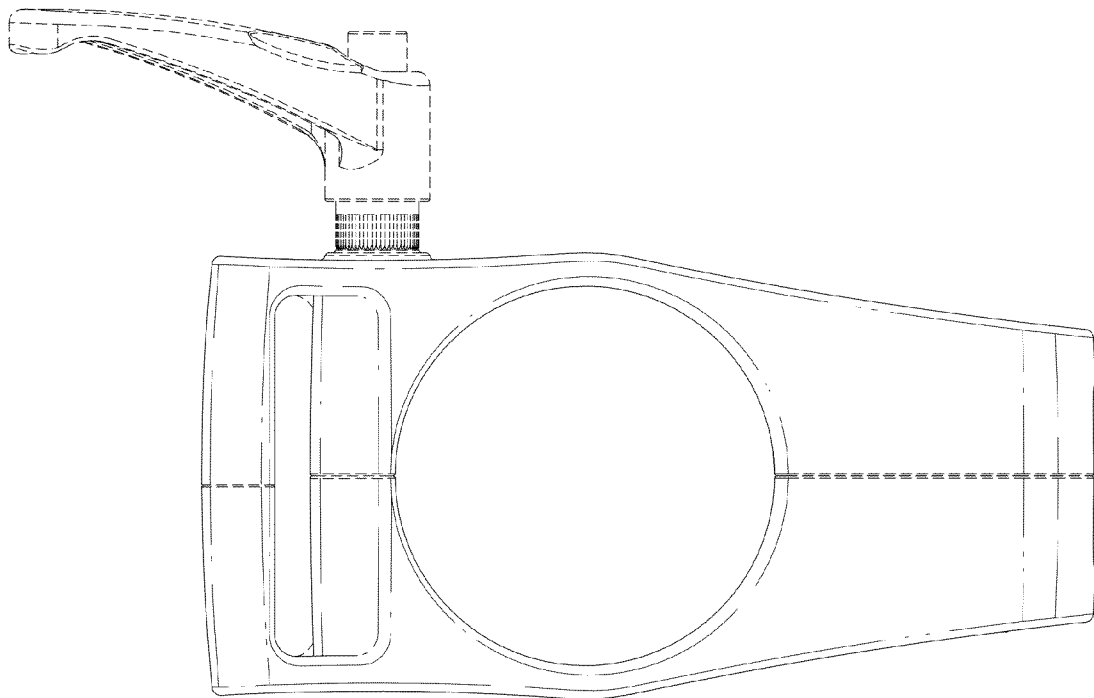

FIG. 9